

NOTES:

Standard Heavy-Duty Rewinder with Sensor Arm, for media up to 6.5" wide, and roll diameters up to 12".

- Max. Roll Diameter: 12" (305mm)
- Core Diameter: 3" (76mm)
- Core Holder: Mechanical Chuck
- Max. Media Width: 6.5" (165mm)
- Full 5-Year Parts and Labor Limited Warranty

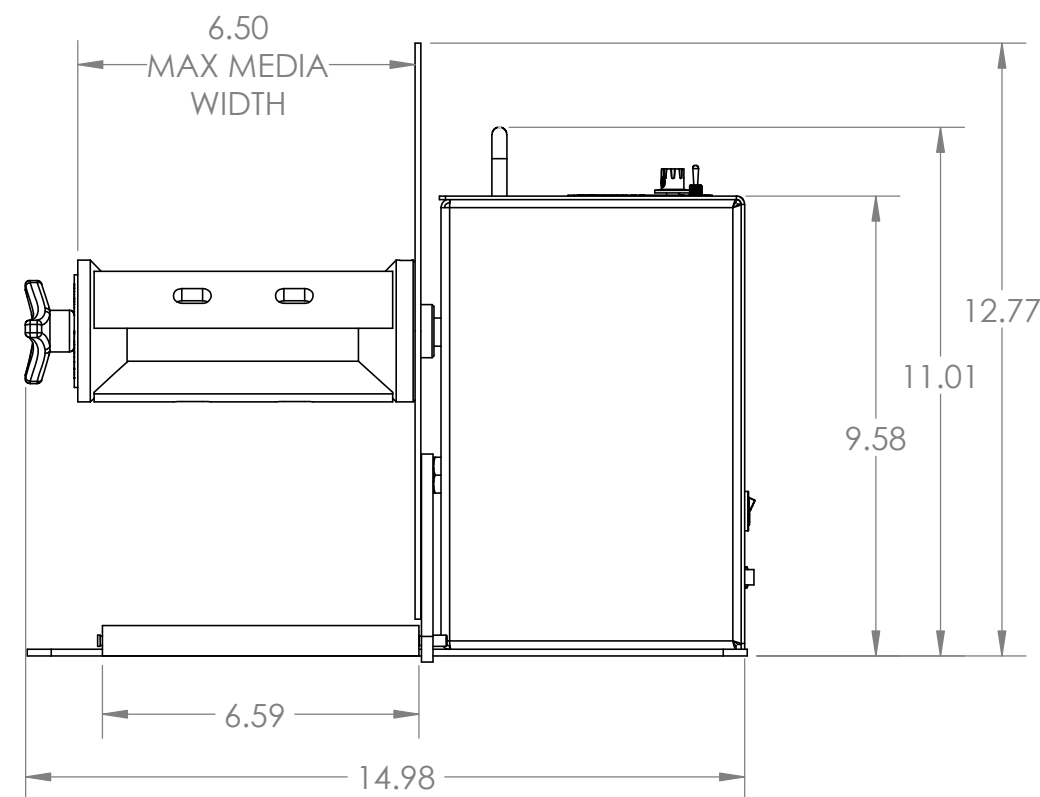
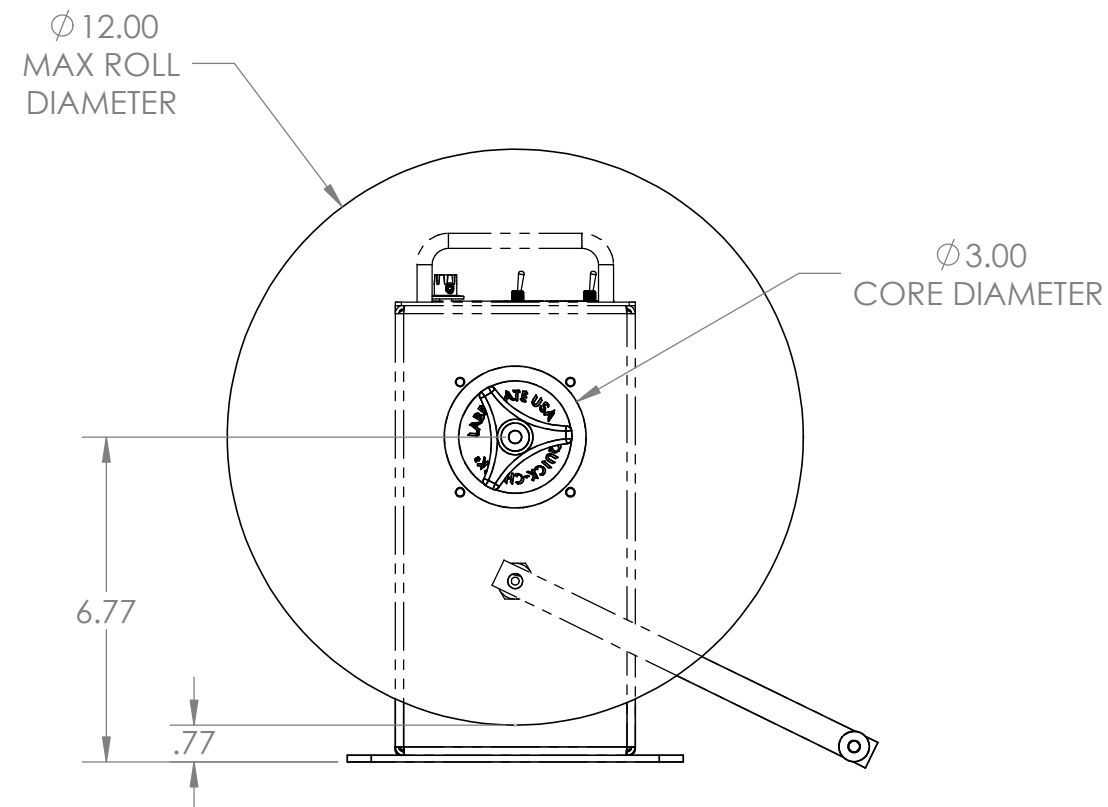

ITEM ID:

CAT-3SA-CHUCK

DRAWN BY: TAH	DATE: 2/1/2023	PART NO. 80-203-0028
------------------	-------------------	-------------------------

POWER SUPPLY: PART NO. PS-1240-R	INPUT: 120VAC OUTPUT: 12VAC 3.3A
-------------------------------------	-------------------------------------