

**NOTES:**

**Standard Heavy-Duty Rewinder with Adjustable Core Holder, for media up to 6.5" wide, and roll diameters up to 11".**

- Max. Roll Diameter: 11" (305mm)
- Core Diameter: 1" - 4" Adjustable (25-101mm)
- Core Holder: Expandable Fingers
- Max. Media Width: 6.5" (165mm)
- Full 5-Year Parts and Labor Limited Warranty

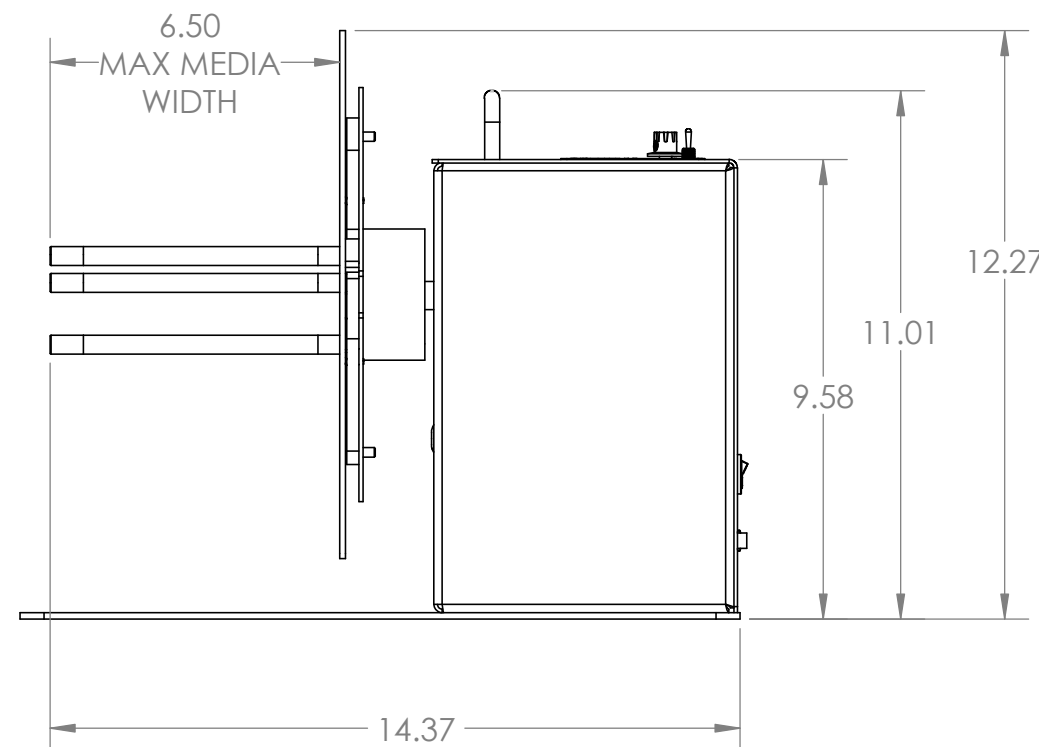
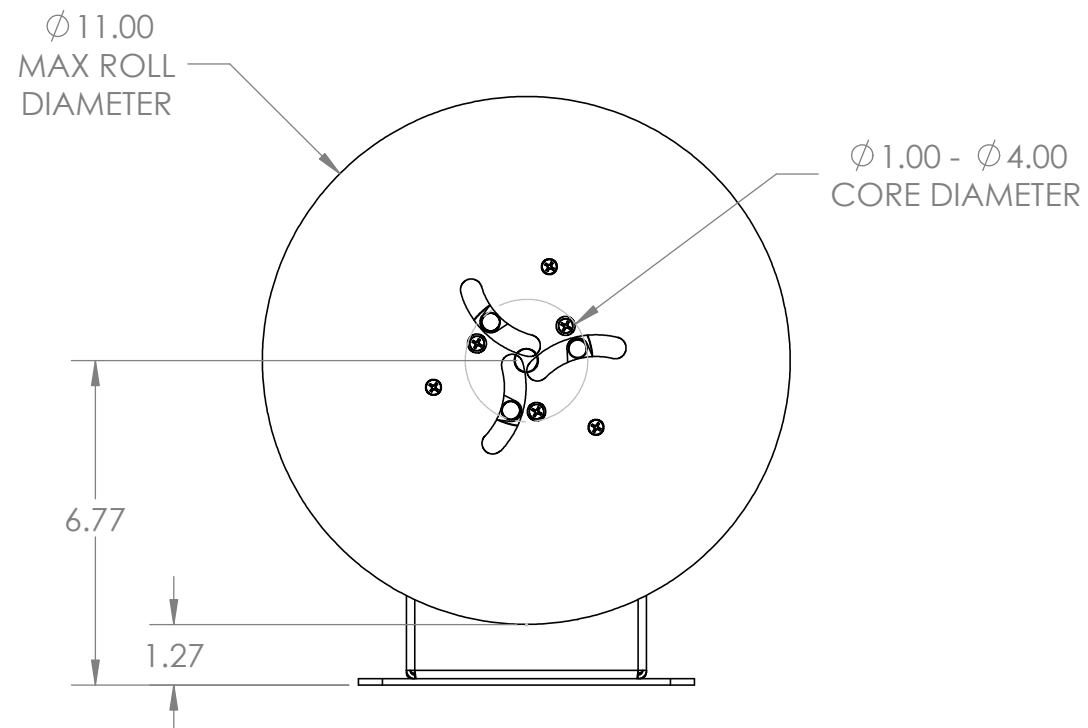
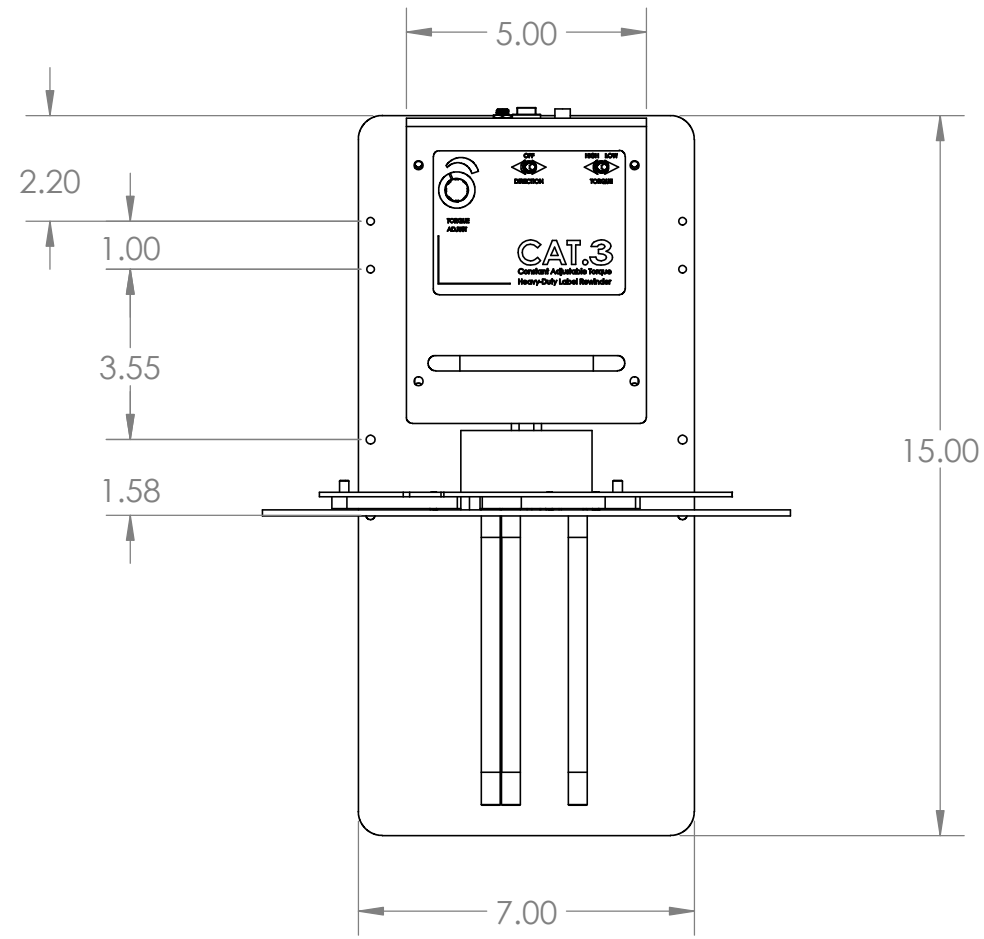

ITEM ID:

**CAT-3-ACH**

DRAWN BY: TAH	DATE: 2/1/2023	PART NO. 80-203-0005
------------------	-------------------	-------------------------

POWER SUPPLY:	INPUT: 120VAC
PART NO. PS-1240-R	OUTPUT: 12VAC 3.3A