

NOTES:

Adjustable Core Holder for CAT Rewinders and UCAT Unwinders.

- Core Diameter: 1" - 4" Adjustable (25-101mm)
- Max. Media Width: 6.0" (152mm)
- Max. Roll Weight: 15 lbs (6.8 kg)
- Mounting: Setscrew, press fit
- Composition: Steel and Anodized Aluminum
- Warranty: 3 Year Parts and Labor Limited Warranty

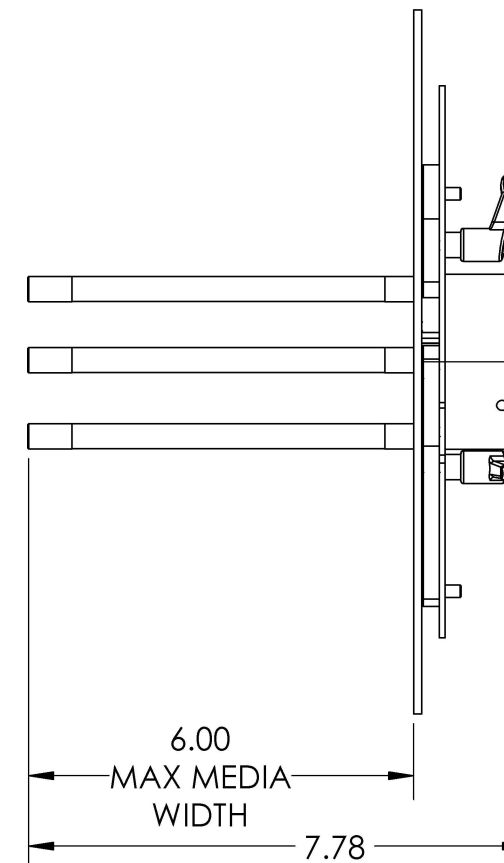
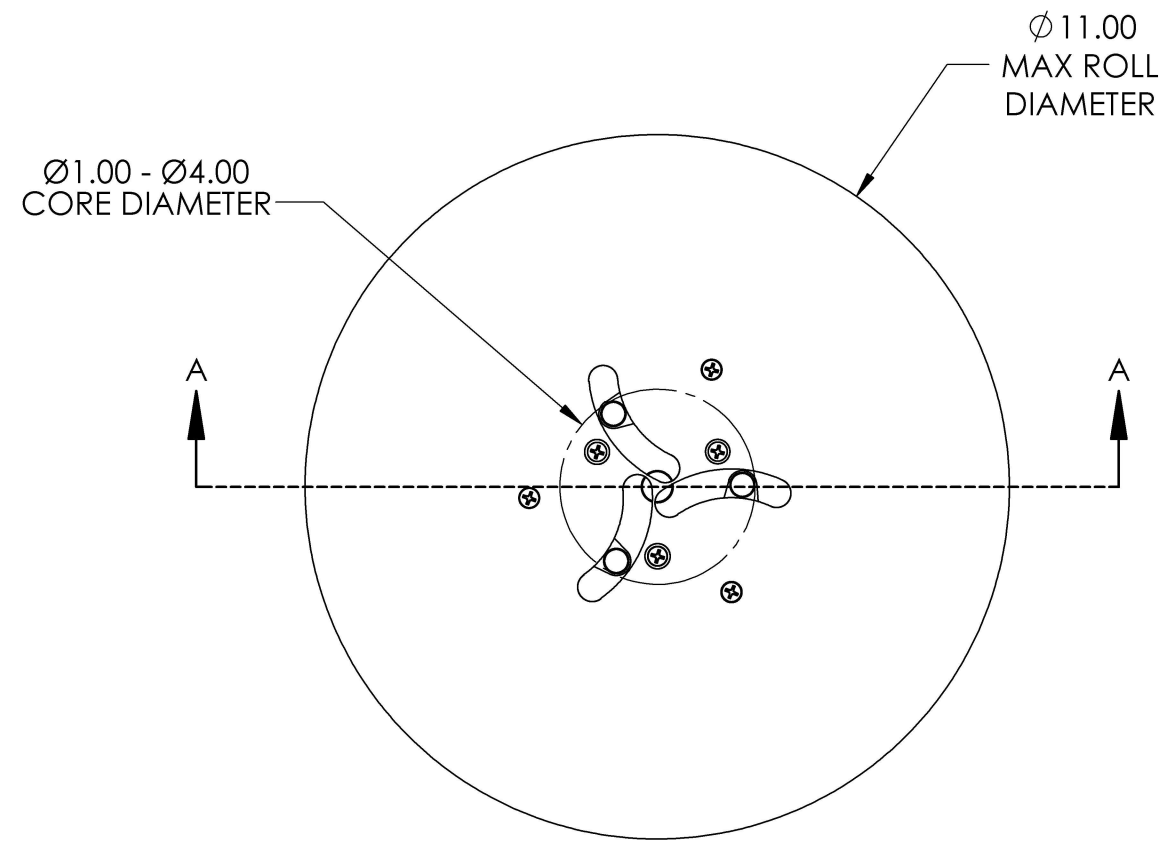
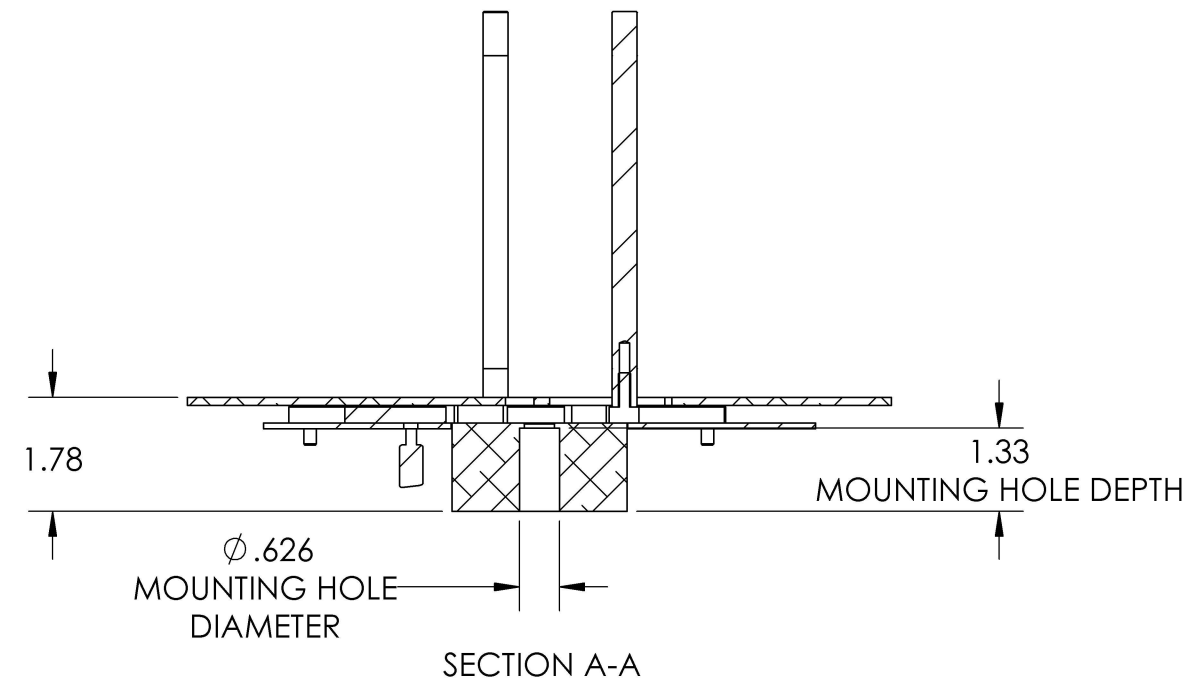

ITEM ID:		
ACH-CAT		
DRAWN BY:	DATE:	PART NO.
TAH	1/1/2024	81-246-0002
POWER SUPPLY:	INPUT:	
PART NO. NONE	OUTPUT:	