

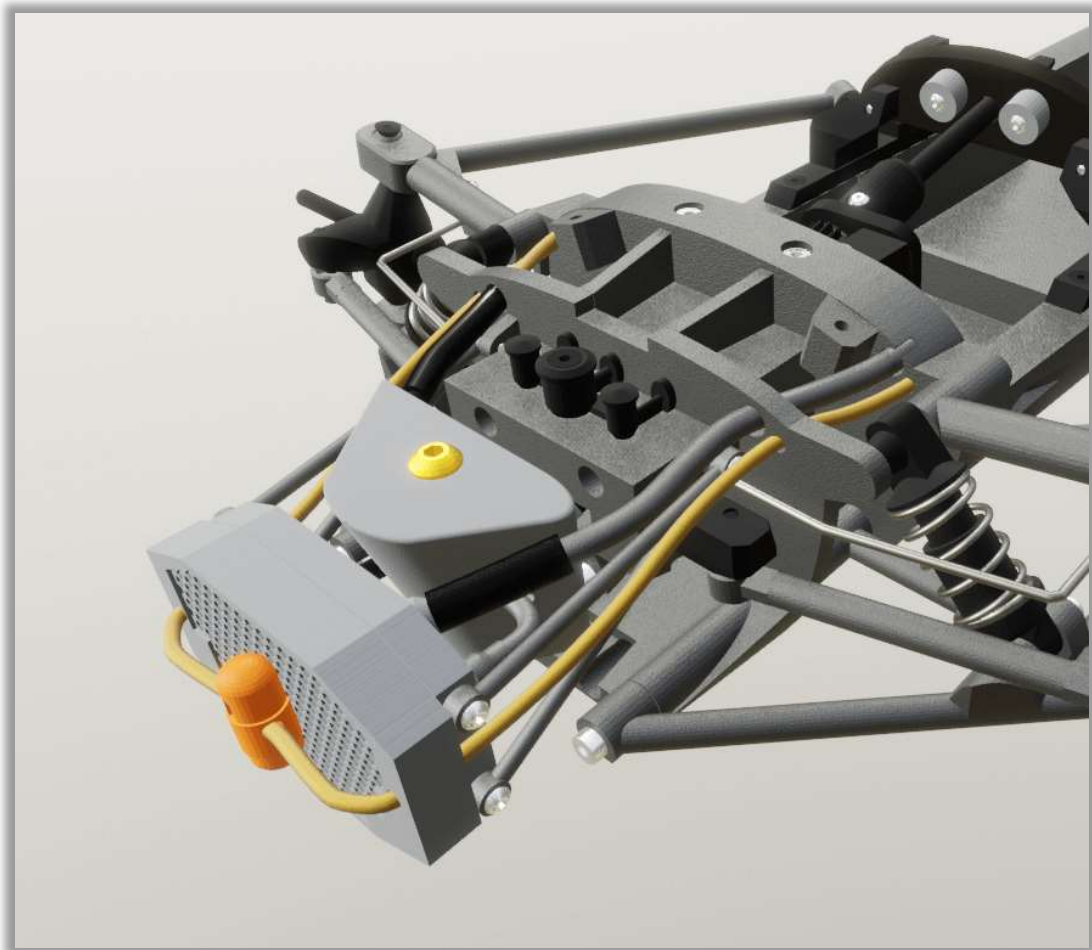

SECTION 5. Radiator & Water Tank

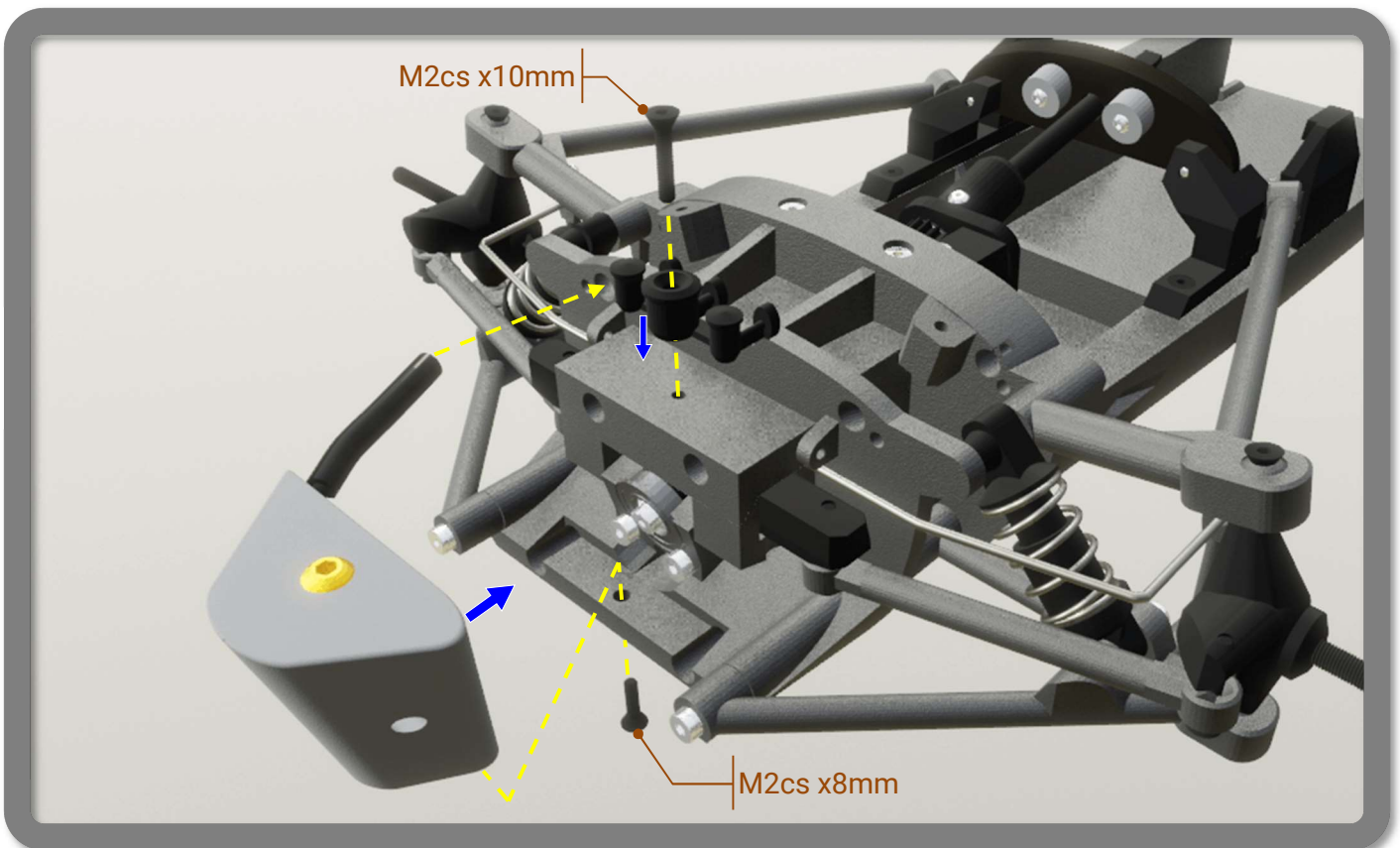

STEP 1 – WATER TANK

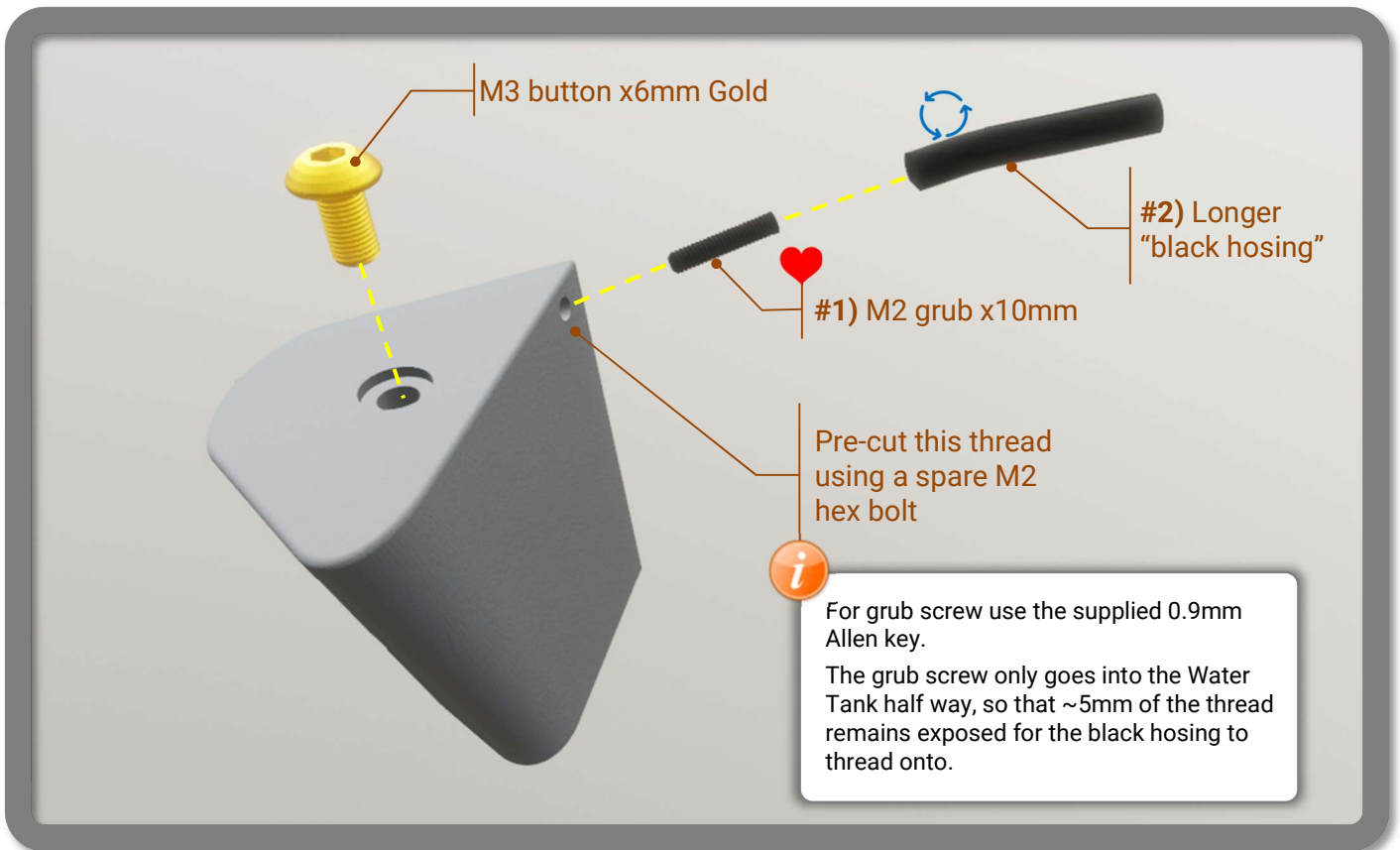

STEP 2 – RADIATOR

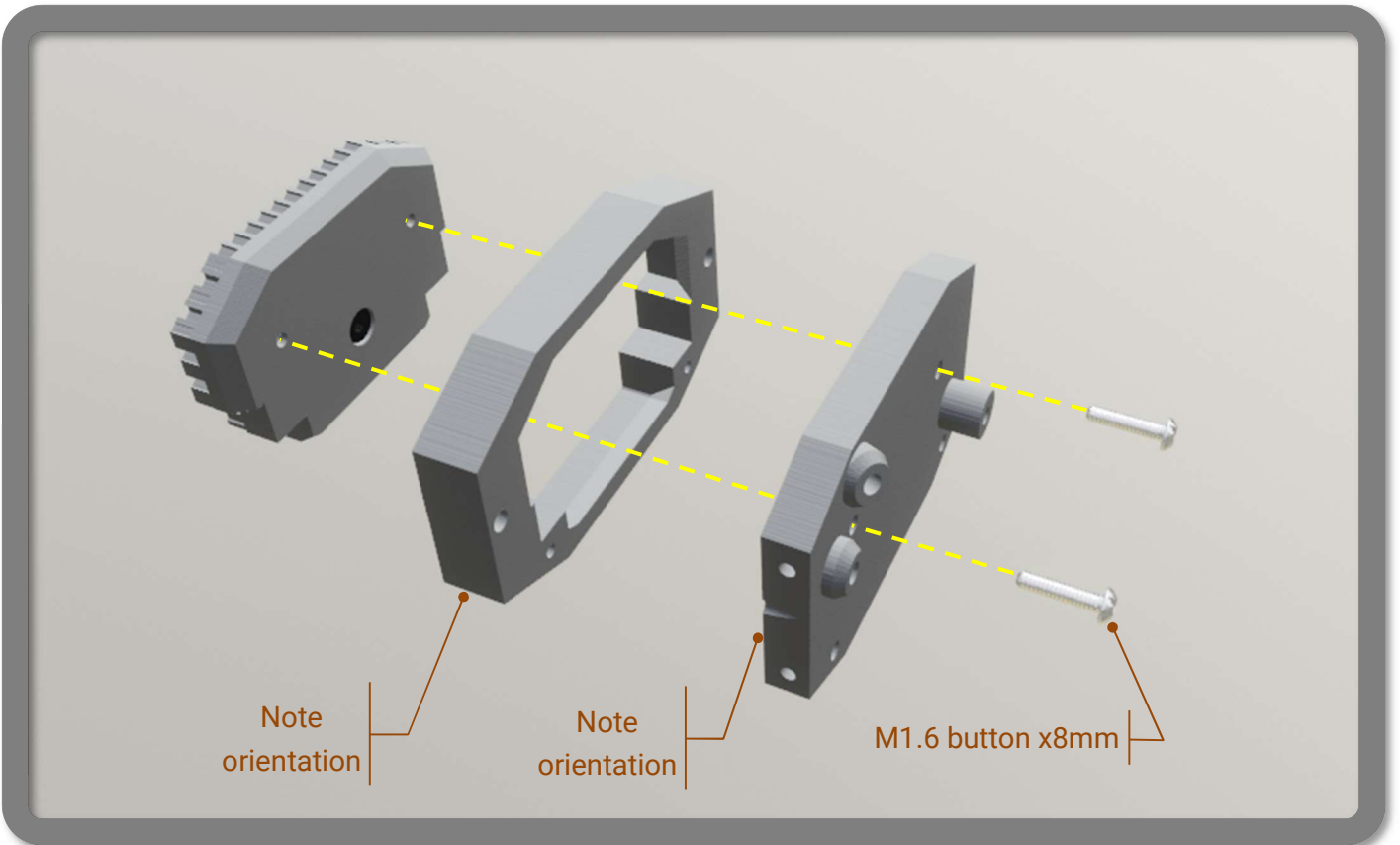
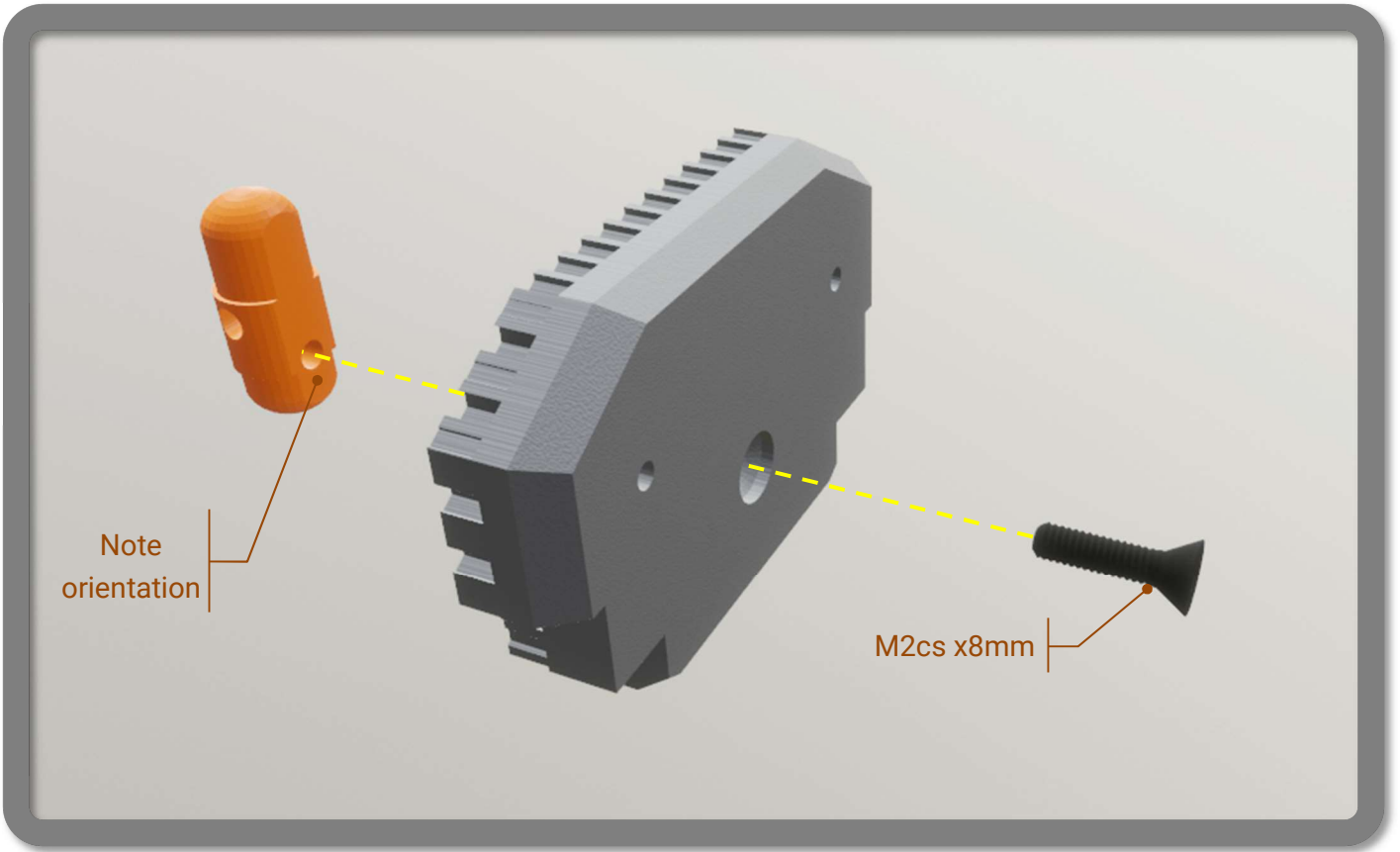

STEP 2 – RADIATOR

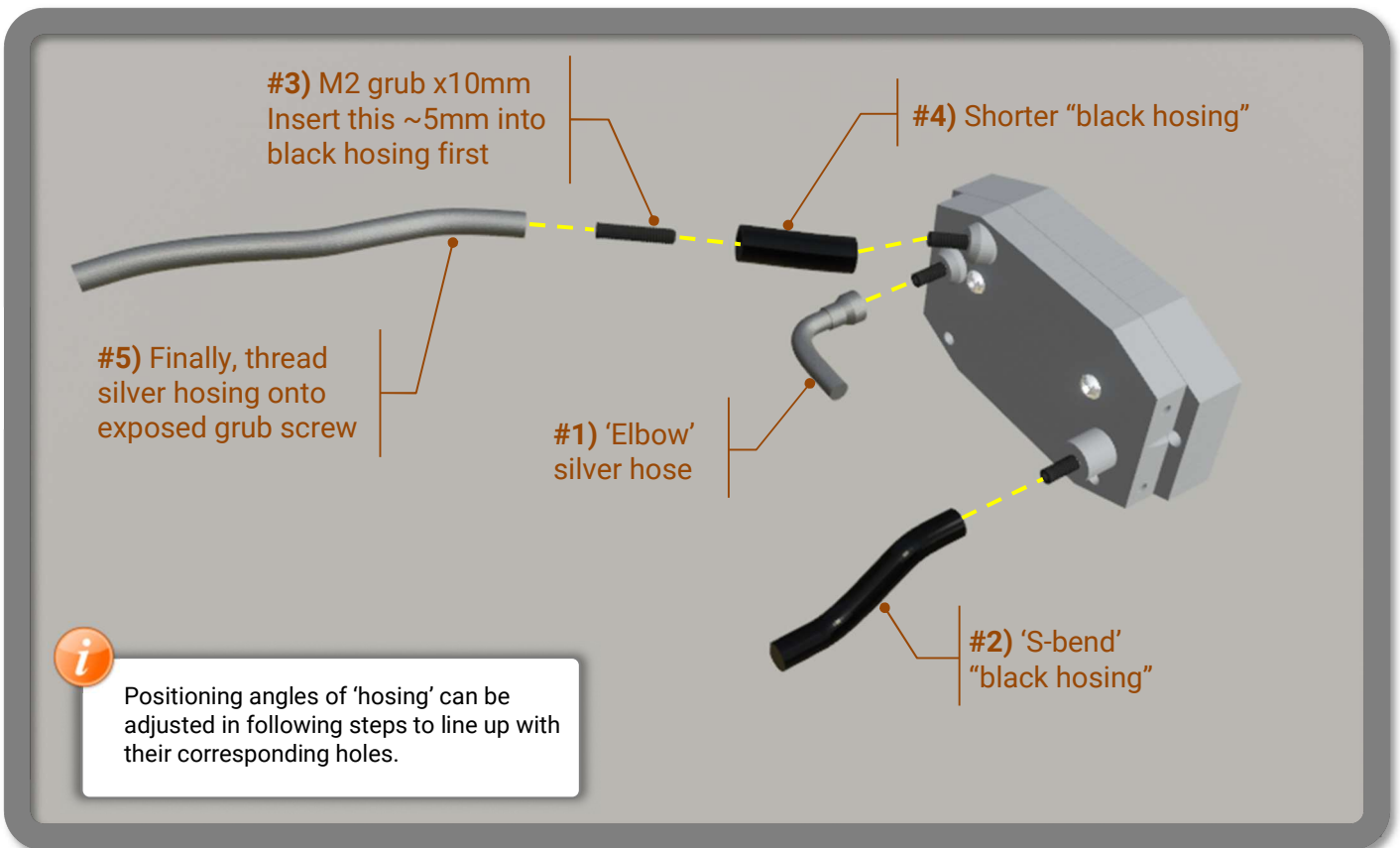
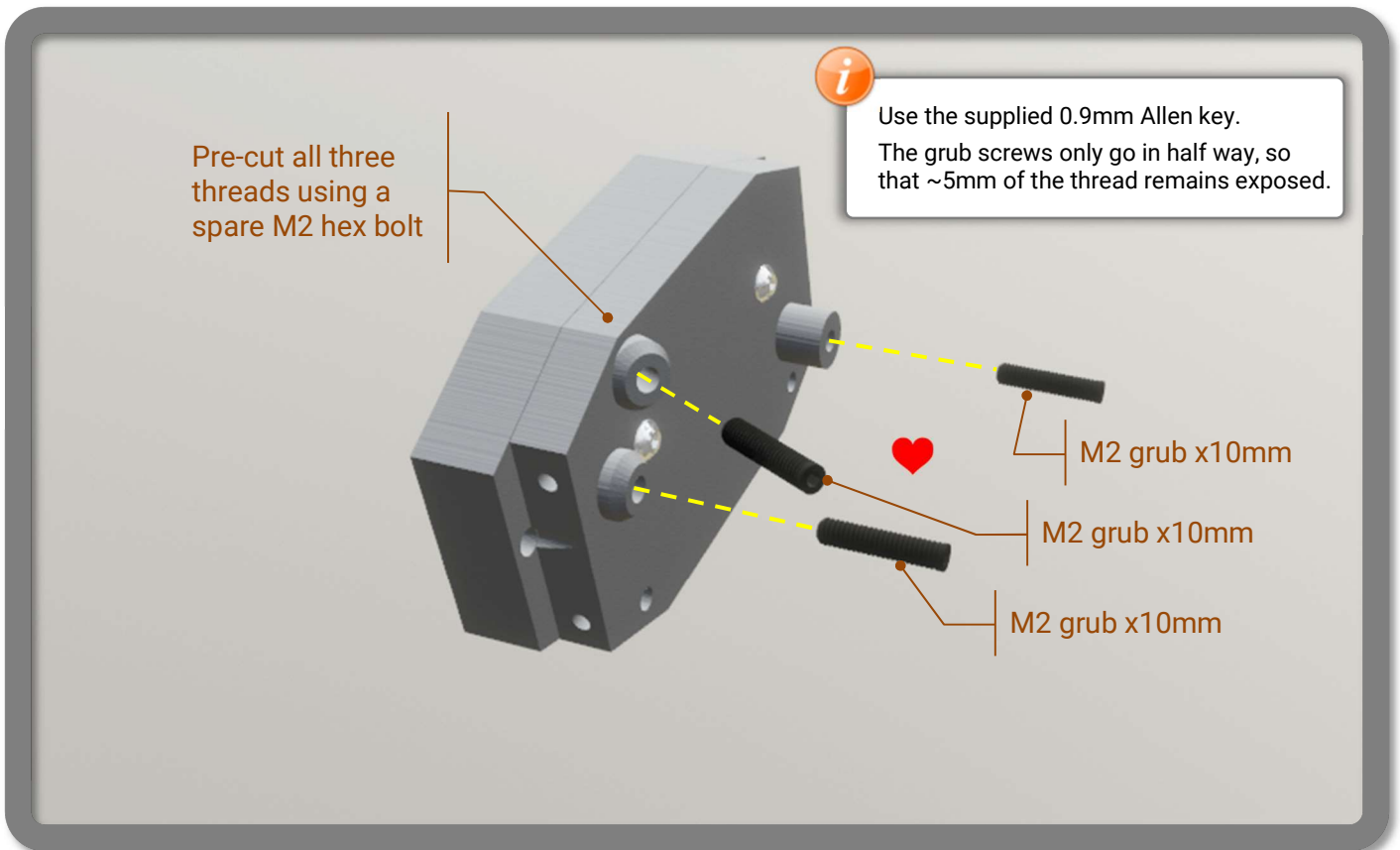

STEP 2 – RADIATOR

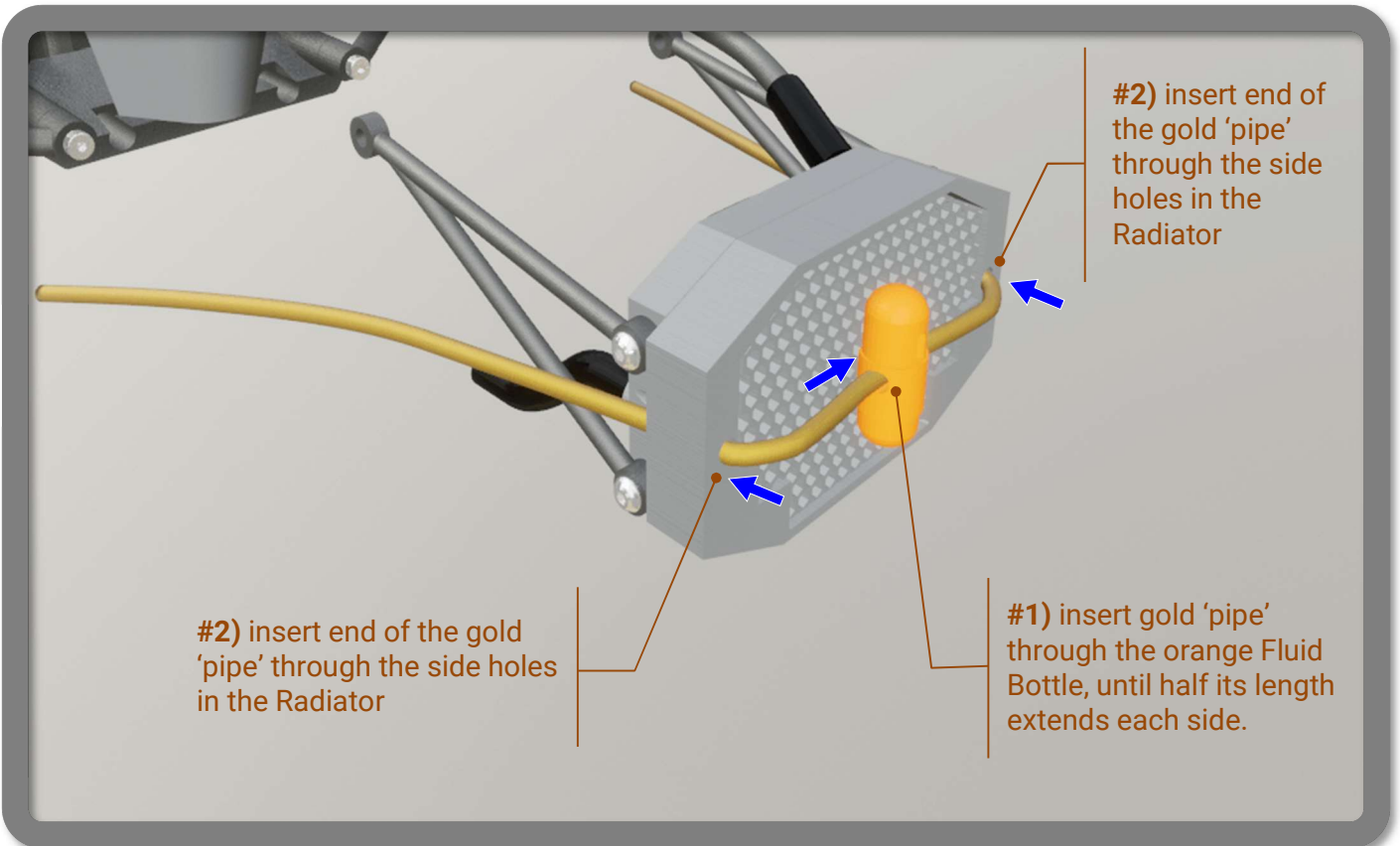
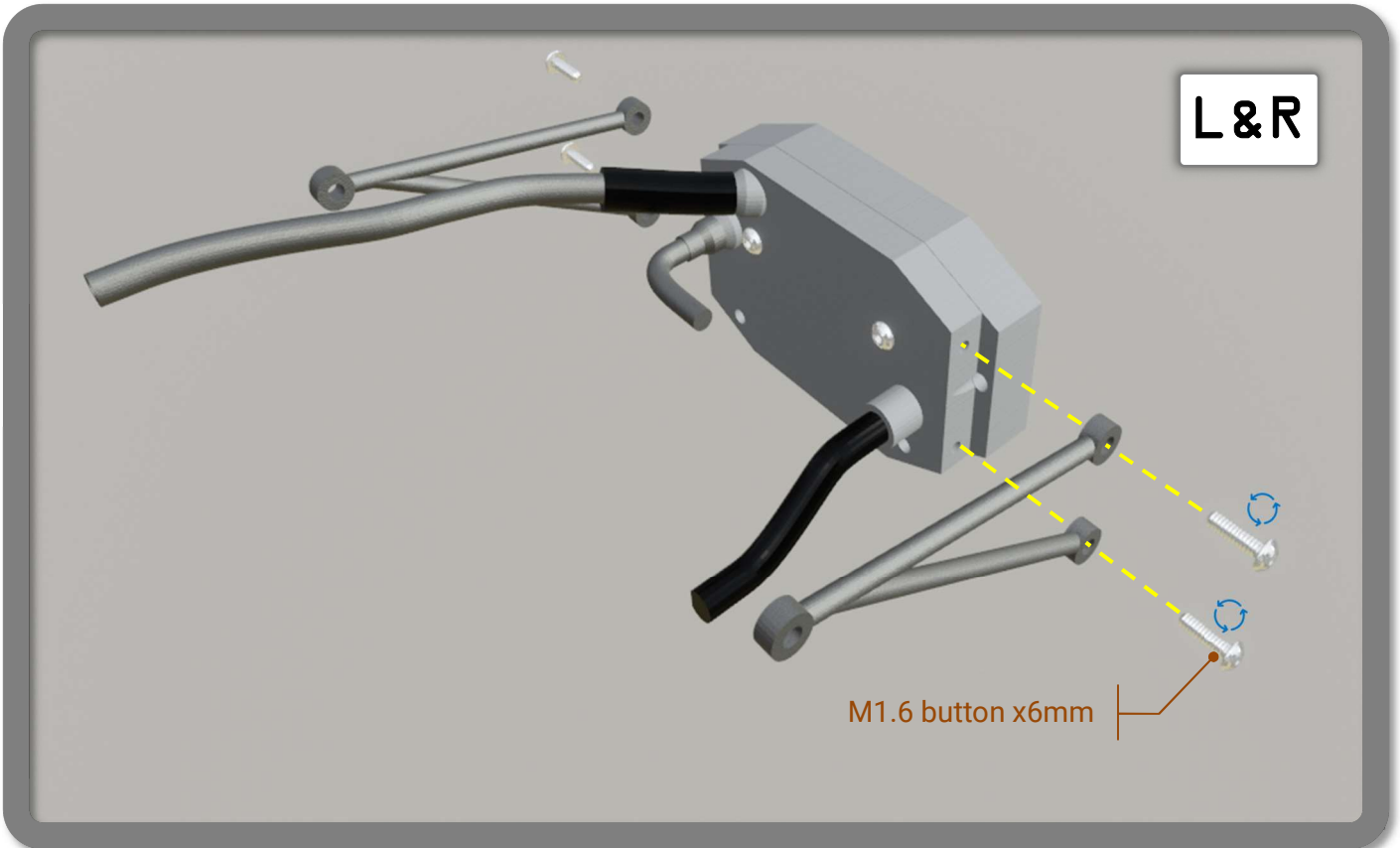

STEP 3 – RADIATOR INSTALL

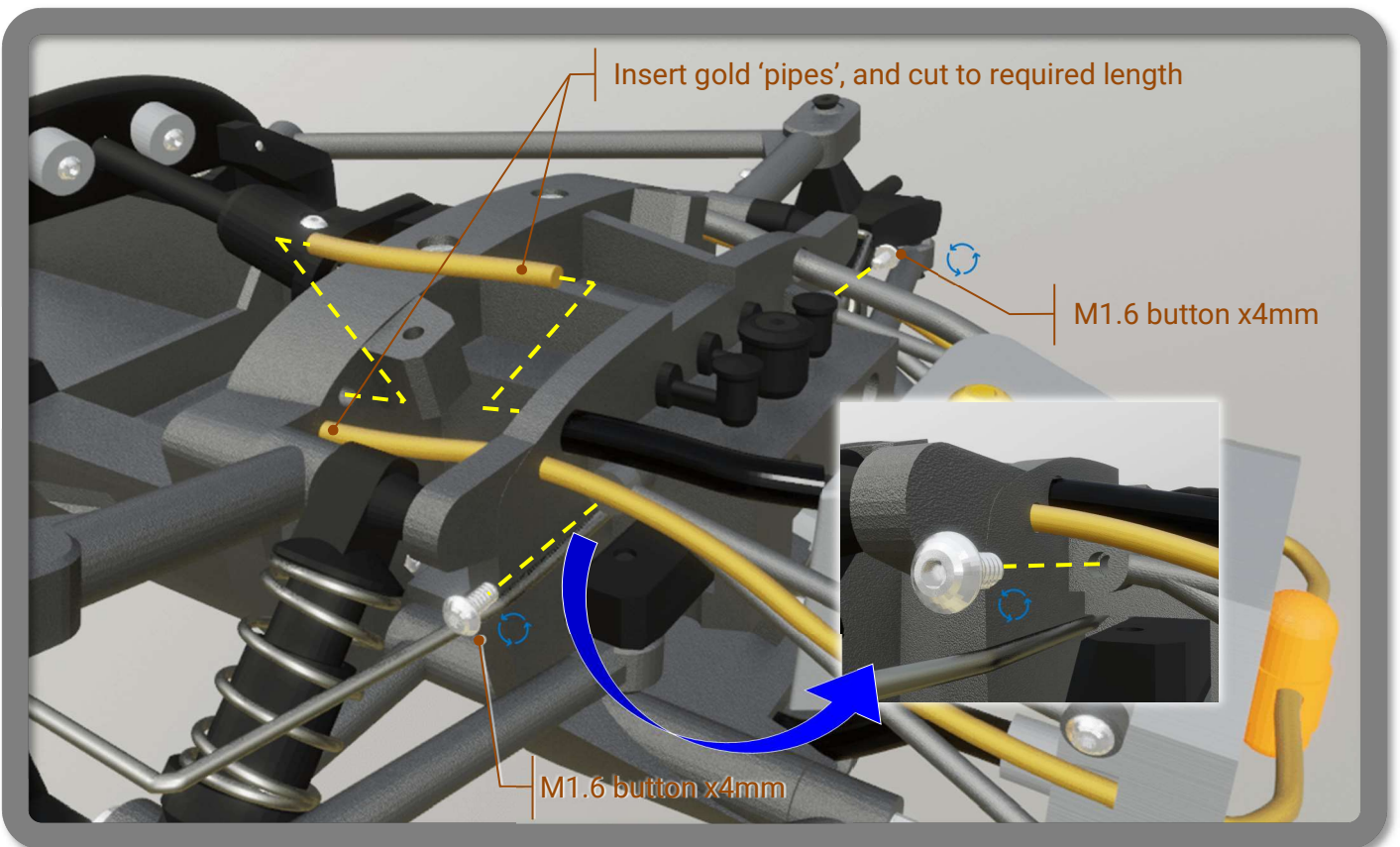
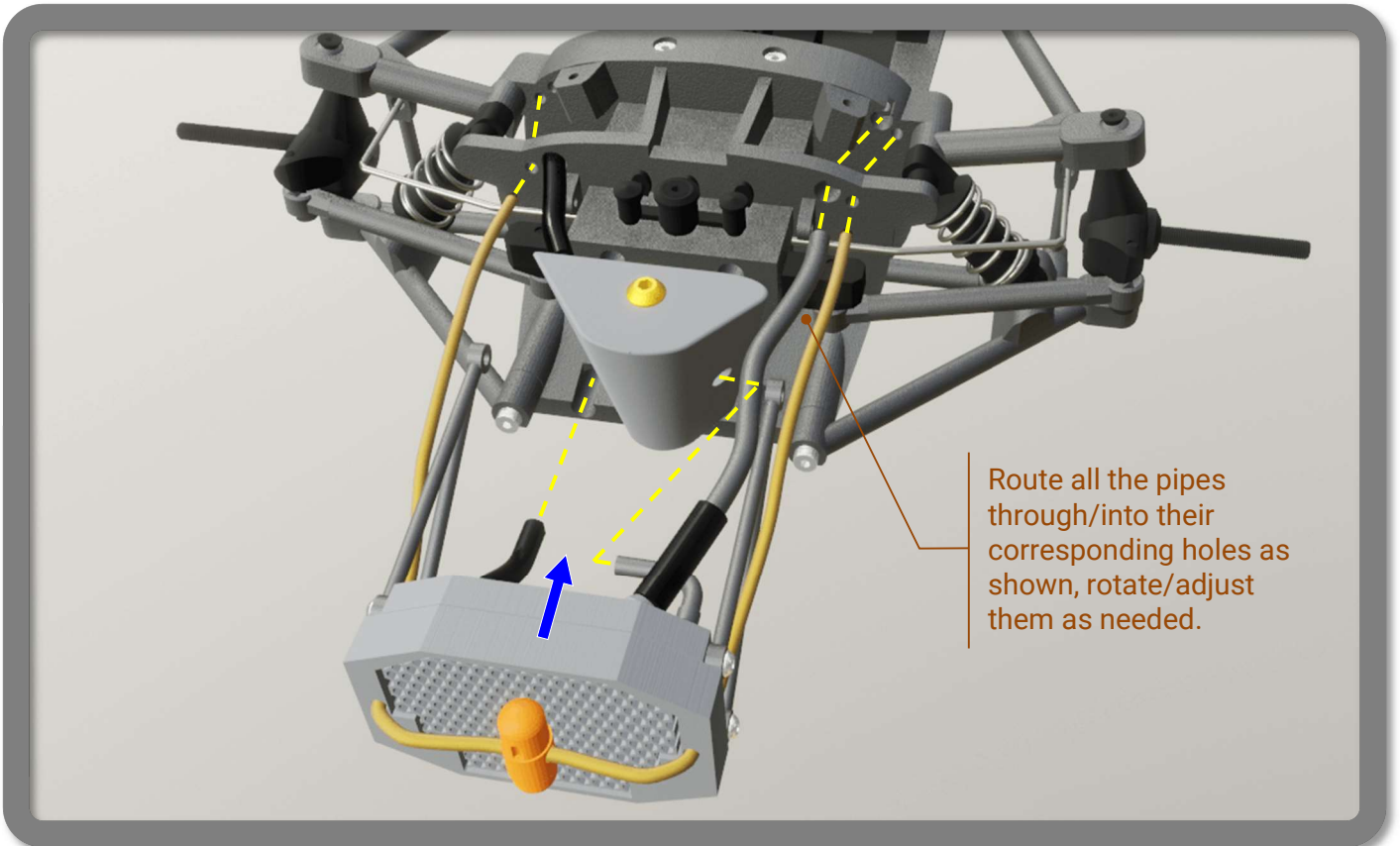

STEP 5 – RADIATOR & WATER TANK – COMPLETED

