

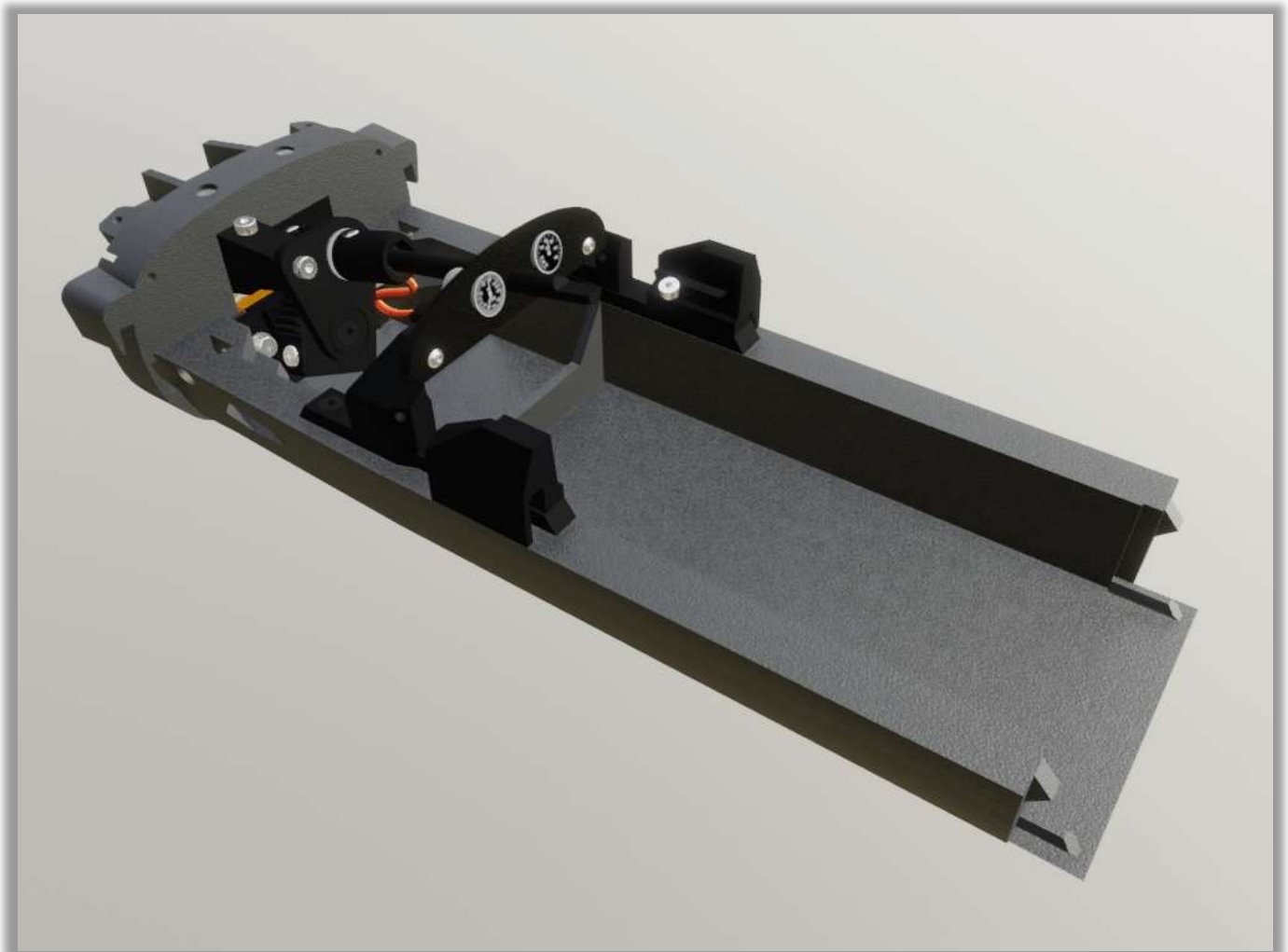

SECTION 2. Chassis & Dashboard

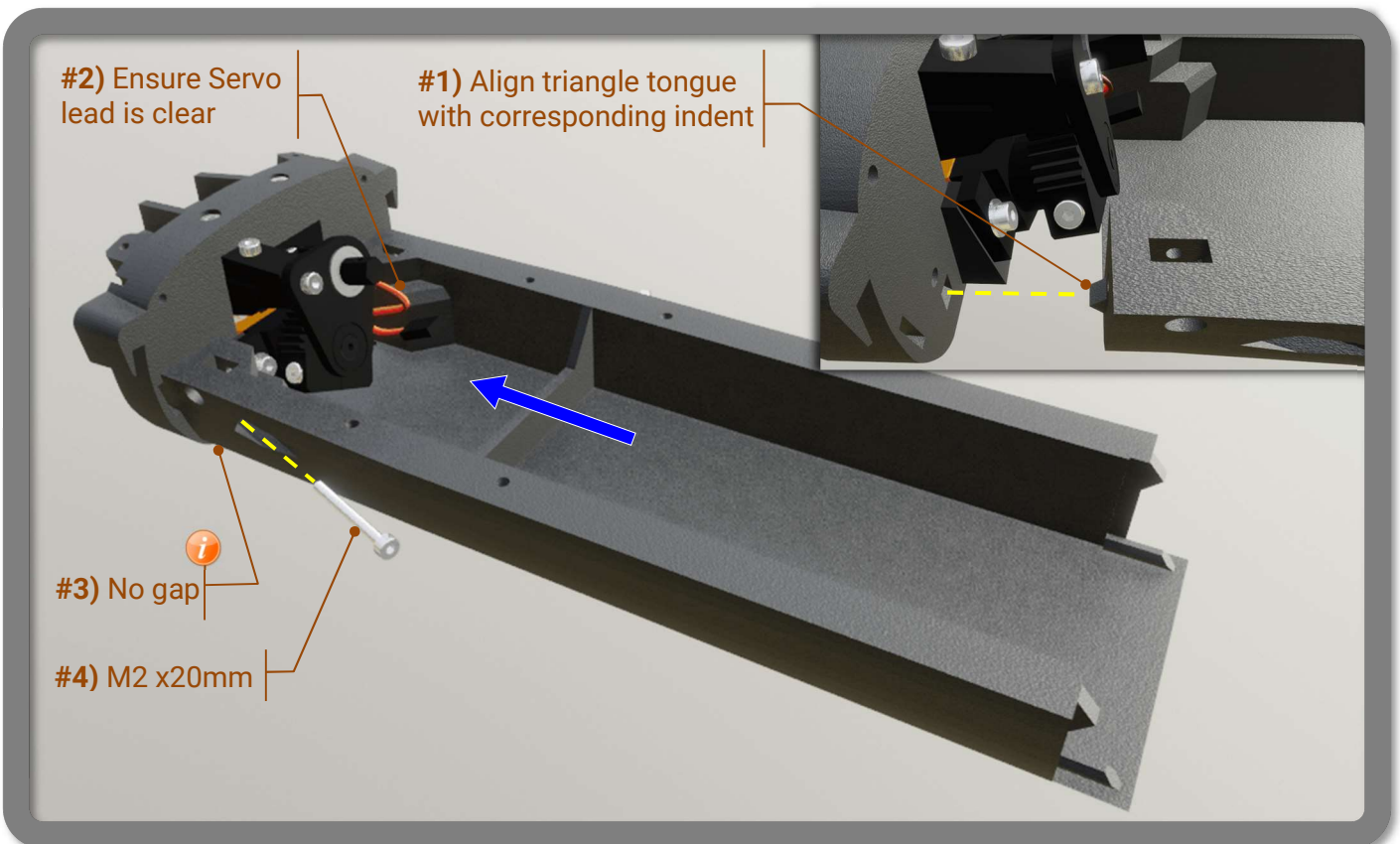

STEP 1 – CHASSIS

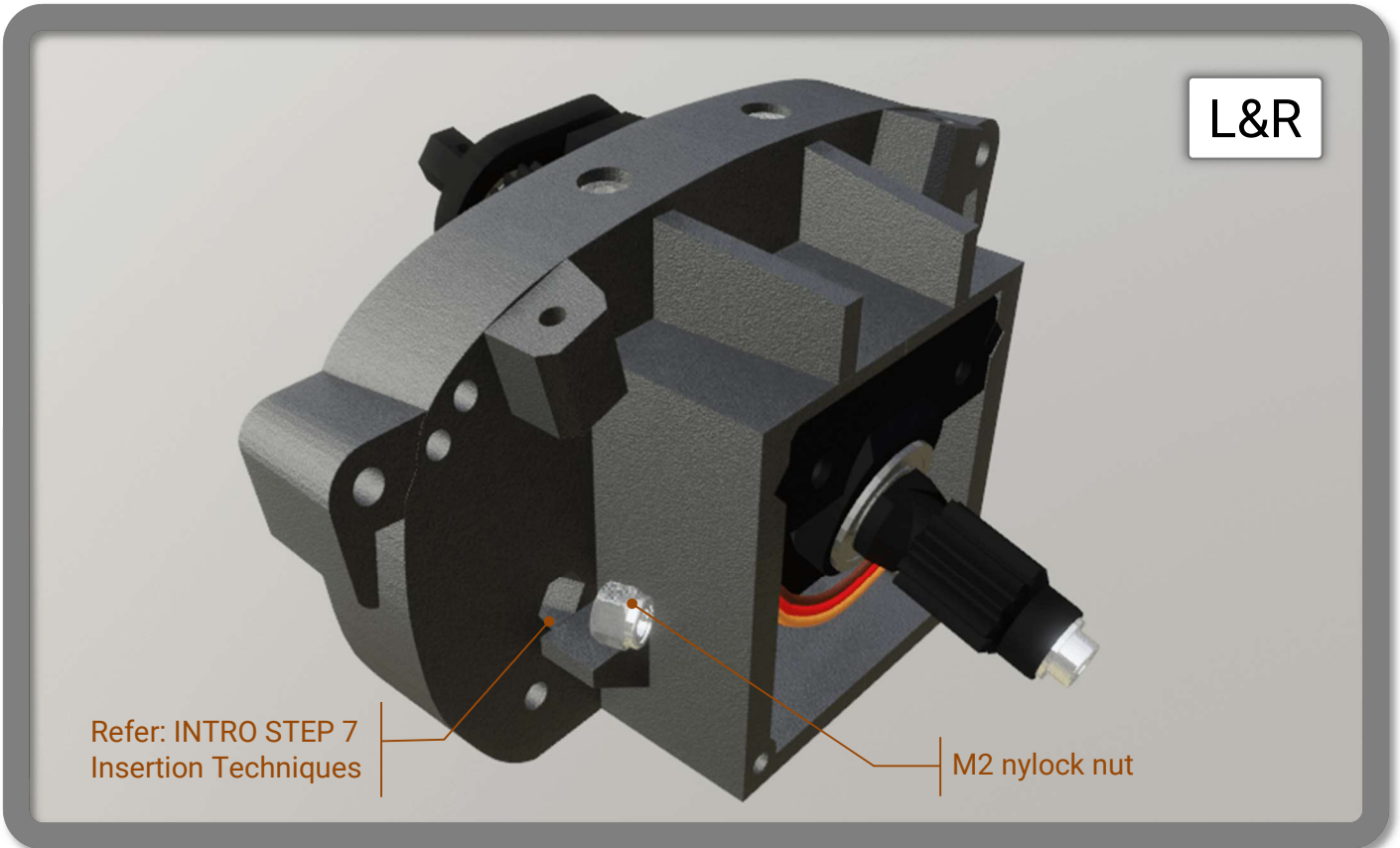

STEP 2 – DASHBOARD SUPPORT

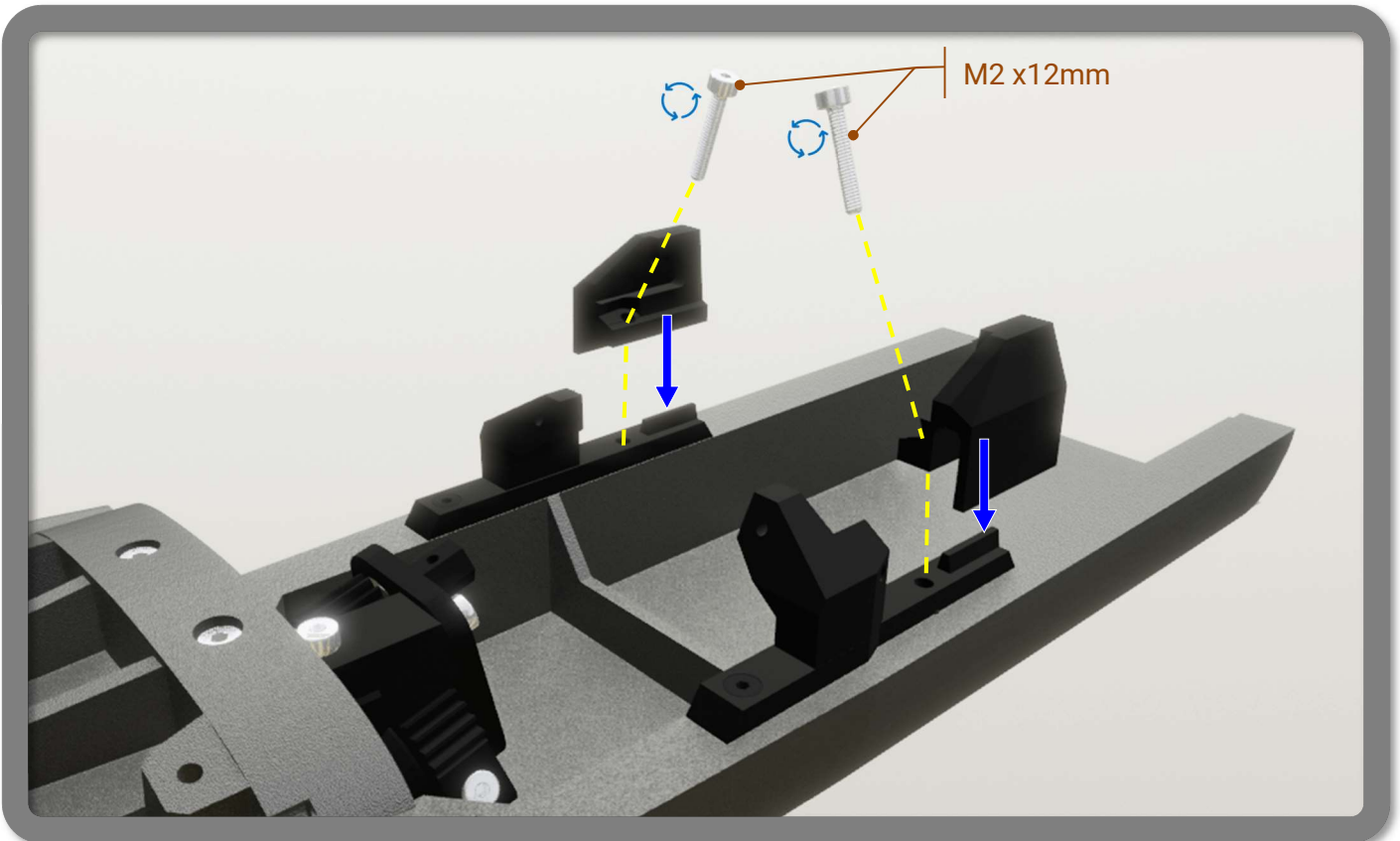
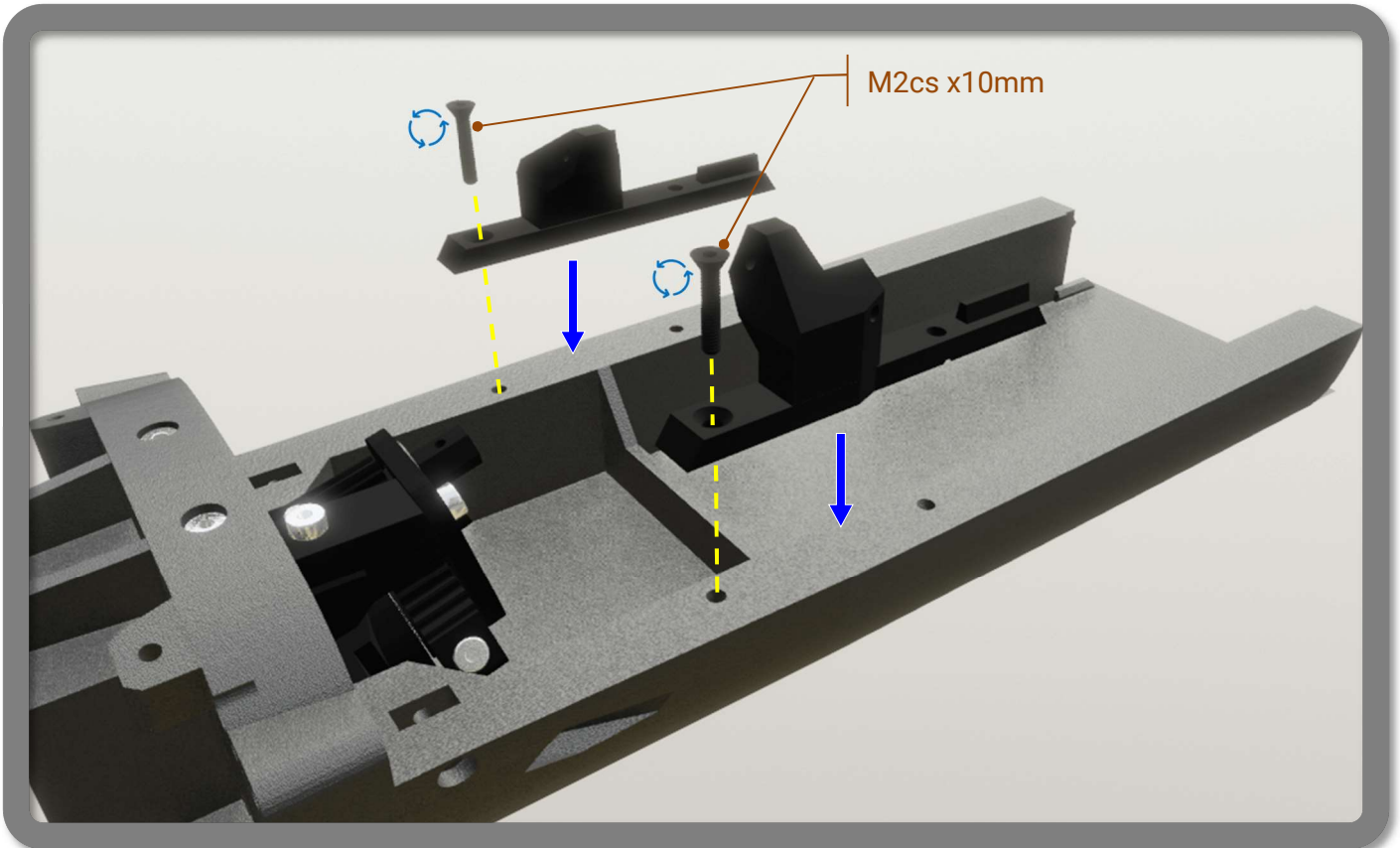

STEP 3 – STEERING COLUMN

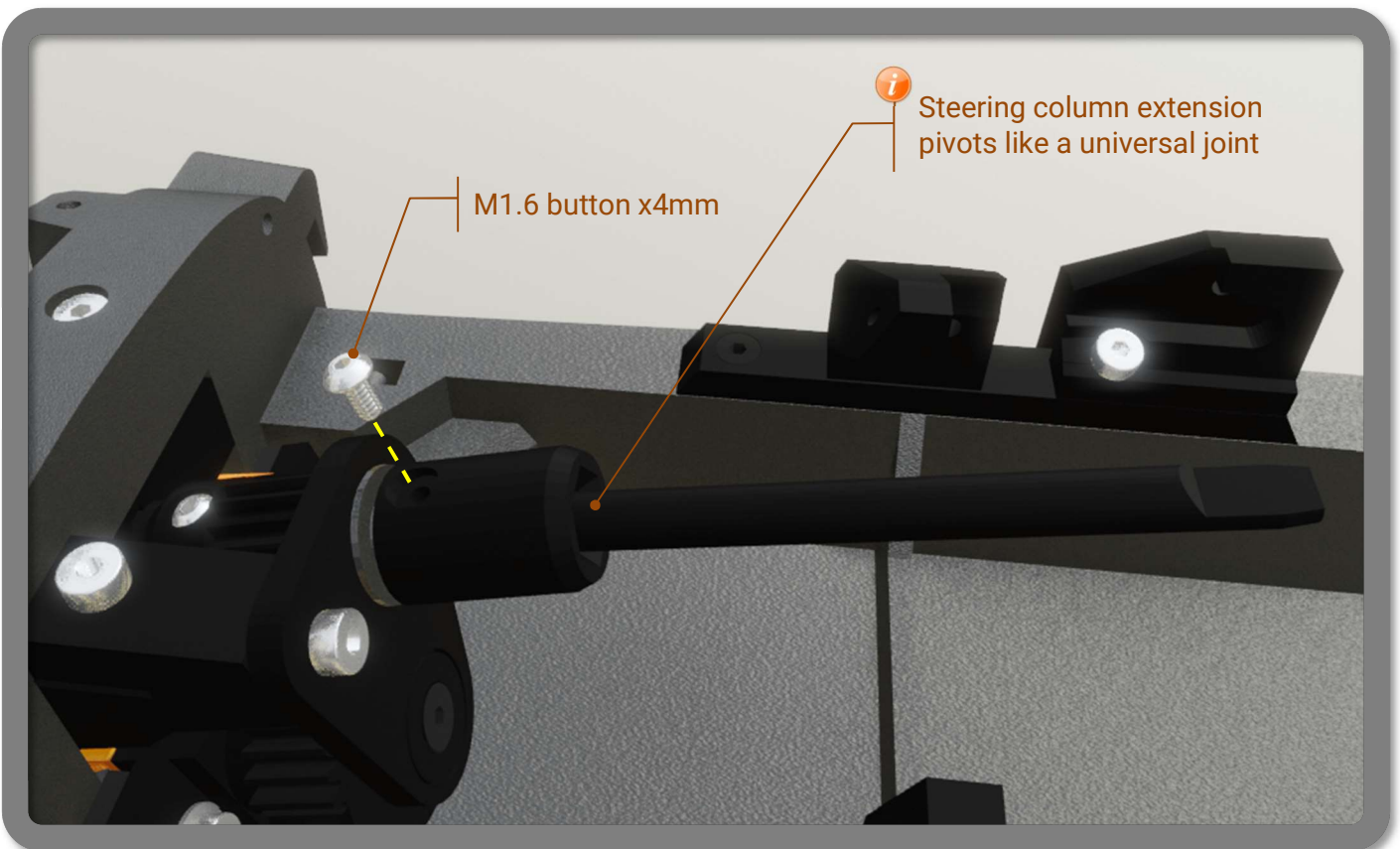
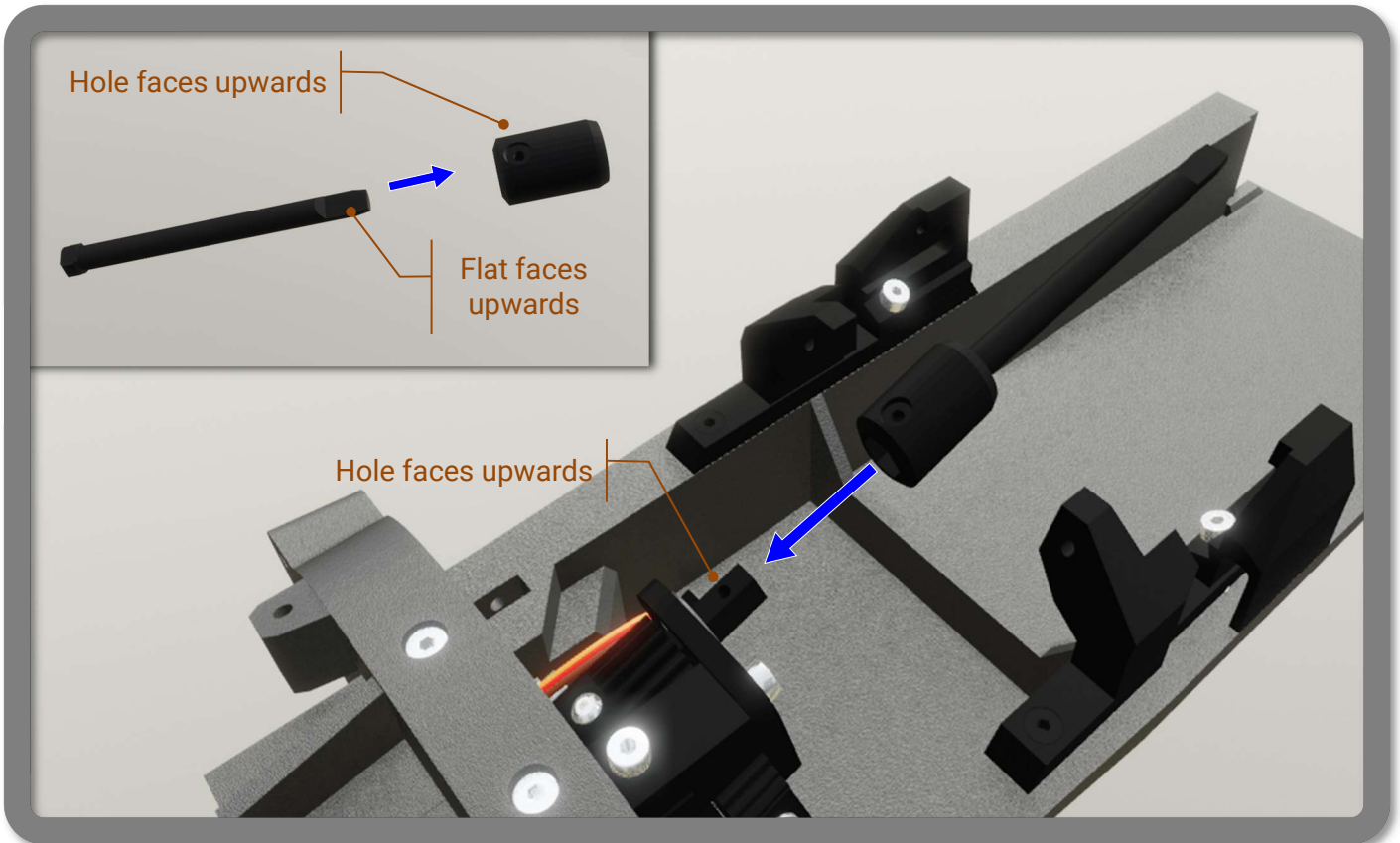

STEP 4 – DASHBOARD

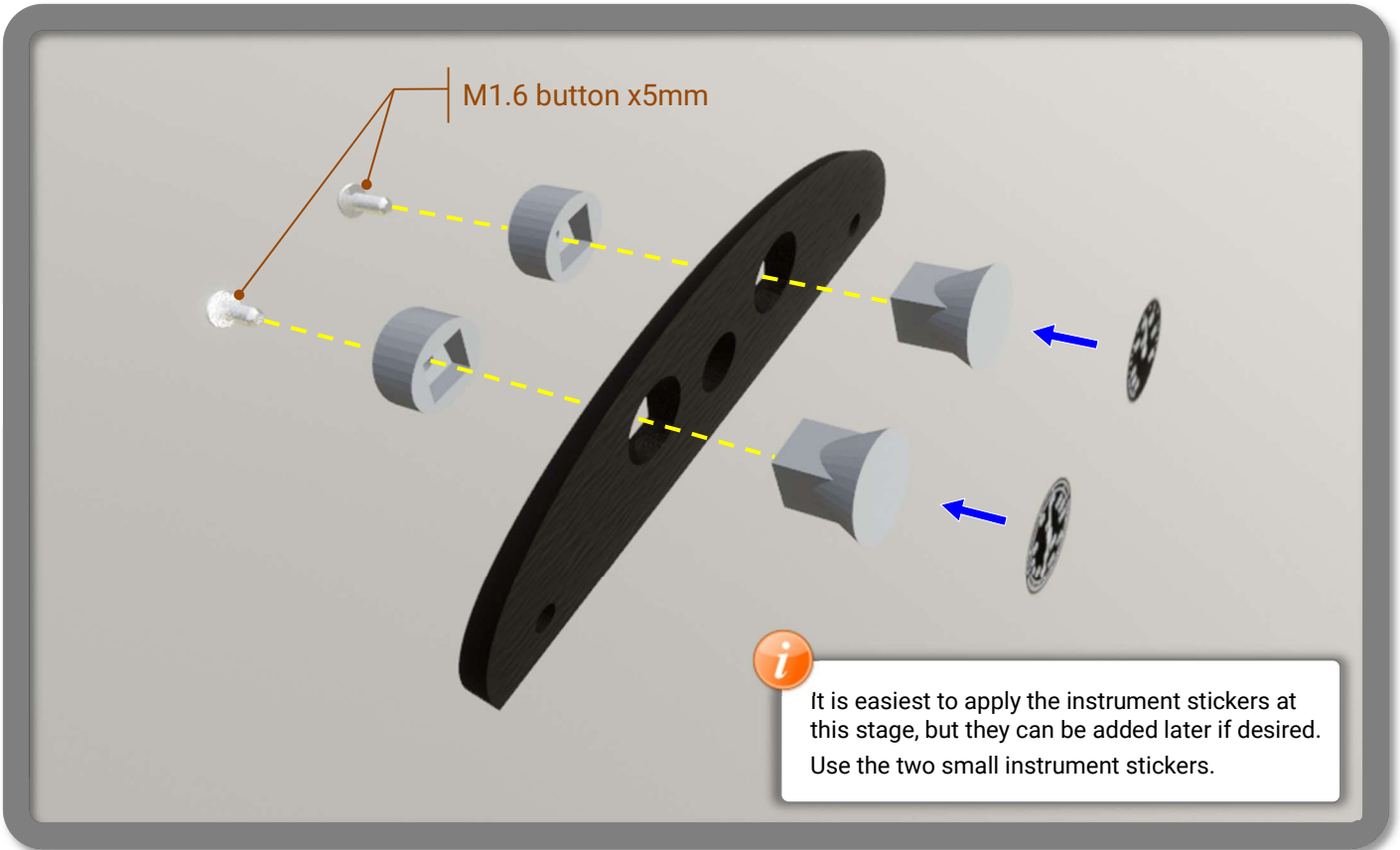

SECTION 2 – CHASSIS & DASHBOARD - COMPLETED

