



## Model FM - Fixed Mount Germicidal Systems 120/240 volt



FM1-16, FM1-12



FM2-16/5, FM2-12/5



FM1-5

### Description

Sterile Sweep® Germicidal UVC Systems and UVC/UVV Systems offer a versatile, full line of whole-house air purification solutions that install directly into the central heating and cooling system ductwork or plenum. The high intensity Dual-Radiant™ UVC “H” Lamp disinfects the air by neutralizing airborne pathogens including bacteria, viruses and mold. According to the EPA, the combined use of filtration and germicidal UVC light is an effective means of preventing the distribution of airborne viruses in occupied spaces. With ultraviolet light, micro-watts translate to effectiveness. Sixteen-inch (16”) UVC lamps produce a very high output of 180 micro-watts @ 1 meter which is significantly higher than most UVC lamps on the market. Twelve-inch (12”) UVC lamps produce 150 microwatts @ 1 meter.



FM3-16/16/5, FM3-12/12/5

### Features

#### UVC & ACTIVATED OXYGEN

- Controls allergens that cause allergic and asthmatic episodes
- Controls or destroys organisms such as mold spores, bacteria and viruses
- Controls noxious odors created by pets, smoke, solvents, and carpets

#### HEAT SINK HOUSING DESIGN

- Dissipates heat from electronic components for improved reliability
- Allows operation at higher temperatures
- Extends ballast life

**LONG LASTING LAMPS**

- One lamp controls bacteria, viruses, and mold spores while the second, adjustable lamp oxidizes gases and removes odors
- Two-year lamps mean replacement only every two years
- Reflex™ lamps focus UVC light in one direction

**AUTO-SENSING MULTI-VOLTAGE**

- Auto sensing ballast automatically compensates 120-277VAC 50/60Hz

**EASY MAINTENANCE**

- 18,000-hour lamps require replacing only once every two years
- LED power and lamp monitors let you know the system is working properly

**ECONOMICAL OPERATION**

- Low static pressure drop lets blower run efficiently

**OPTIONAL ACCESSORIES**

- Offset Duct Board Adapter Plate
- Lamp Reflector Kits

**FAST INSTALLATION**

- Installs in just minutes without costly ductwork modifications
- Suitable for up to a 10 ton AHU

**WARRANTY**

- Limited Lifetime warranty on all electronic components
- Lamp is warranted against defects for two (2) years

**Parts & Accessories**

Description	Part No.
36W Replacement H Lamp (2 Year) 16" only	LSK-36-16
24W Replacement H Lamp (2 Year) 12" only	LSK-24-12
21W Replacement H Lamp (2 Year) 7" only	LSK-21-7
36W Reflex Replacement H Lamp (2 Year) 16" only	LSK-36-16-RF
24W Reflex Replacement H Lamp (2 Year) 12" only	LSK-24-12-RF
36W Spliced Replacement H Lamp (2 Year) 16" only	LSK-36-16-O3
Replacement Lamp Kit (16" & 5")	LSK-25403-16
Replacement Lamp Kit (12" & 5")	LSK-25403-12
Reflex Replacement Lamp Kit (16" & 5")	LSK-25403-16-RF
Reflex Replacement Lamp Kit (12" & 5")	LSK-25403-12-RF
UVV Replacement Lamp (2 Year) 5" only	LSK-503-5
FM Offset Duct Board Adapter Plate Kit (optional)	500423FM-OS
16" Lamp Reflector for Mount Plate w/ magnetic mount (optional)	500484-MAG
16" Lamp Reflector for Mount Plate (optional)	500484
12" Lamp Reflector for Mount Plate w/ magnetic mount (optional)	500489-MAG
12" Lamp Reflector for Mount Plate (optional)	500489
Replacement Ballast for FM1	BL-710-FM1
Replacement Ballast for FM2	BL-710-FM2
Replacement Ballast for FM3 (2 Required)	BL-710-FM1
Current Sensing Relay Kit for UVV Models	FCS003

# Specifications

Electrical:	
Electrical Input:	110-277V/1/50-60 Auto Sensing
UV Lamp 16" (2 Year)	36 watt, 180 $\mu\text{w}/\text{cm}^2$ @1 meter
UV Lamp 12" (2 Year)	24 watt, 150 $\mu\text{w}/\text{cm}^2$ @1 meter
UV Lamp 7" (2 Year)	21 watt, 80 $\mu\text{w}/\text{cm}^2$ @1 meter
UVV Lamp 5" (2 Year)	8 watt
Activated Oxygen Generation:	50 mg per hour max.



Offset Duct Board Adapter Plate  
500423FM-OS



Lamp Reflector with Magnetic Mount  
500489-MAG (12"), 500484-MAG (16")



Current Sensing Relay  
FSC003

Note: The FCS003 Current Sensing Relay interlocks the UVC/UVV System with the furnace blower (this field installed option is recommended on all UVV installations).

# Weights and Dimensions

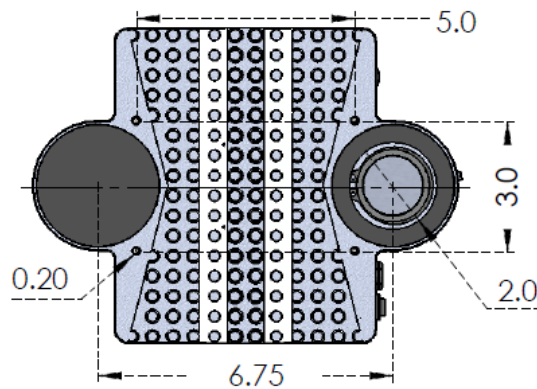
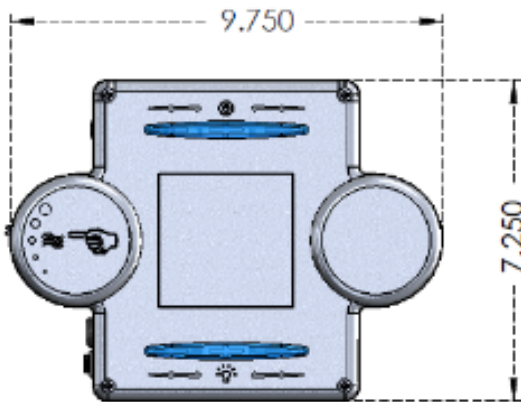

Mounting Hole Pattern

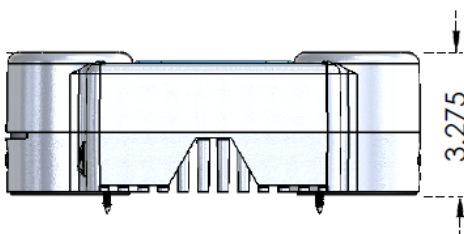

**Dimensions**

- Enclosure: 9.75" x 7.25" x 3.275" (24.8 cm x 18.4 cm x 8.3 cm)
- Lamp Bulb (16"): 16" (40.6 cm) and 5" (12.7 cm)
- Lamp Bulb (12"): 13" (33.0 cm) and 5" (12.7 cm)
- Optional Mounting Plate Overall: 11-1/2" x 13" x 1-1/2"  
(29.2 cm x 33 cm x 3.8 cm)

**Clearances**

- Inside Duct Clearance (16"): 15-1/4" (38.7 cm)
- Inside Duct Clearance (12"): 12-1/2" (31.7 cm)
- UVC and UVV Lamp Opening Size: 2" (5.1 cm)

**Weights**

- FM1-16 Lamp and Enclosure: 4.85 lbs. (2.2 kg)
- FM1-5 Lamp and Enclosure: 5.35 lbs. (2.4 kg)
- FM2-16/5 Lamps and Enclosure: 5.6 lbs. (2.7 kg)

Clean Air Defense System  
P.O. Box 1258  
Princeton, NJ 08542  
Tel: (800) 578-7873  
[www.CleanAirDefense.com](http://www.CleanAirDefense.com)

Specifications are subject to change without notice.  
Clean Air Defense System is a registered trademark  
of Environmental Dynamics Group, Princeton, NJ.