

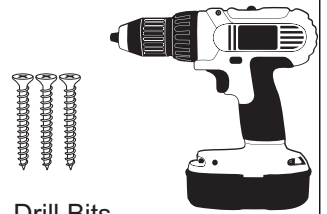

Ceremonial Sledgehammer Plaque Assembly Instructions

Tools Needed



Drill Bits

 9/64"

 #2 Phillips Head

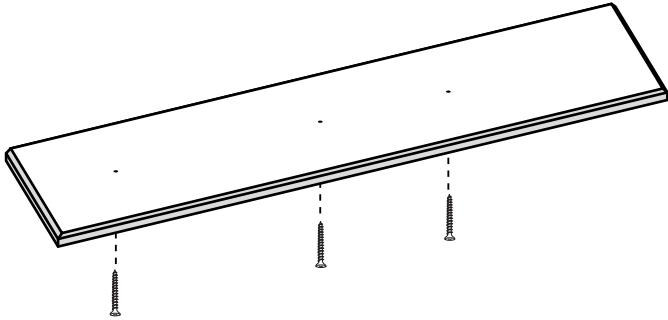

1

Screw (3) of the supplied screws into the pre-drilled holes. Screw them in all the way.

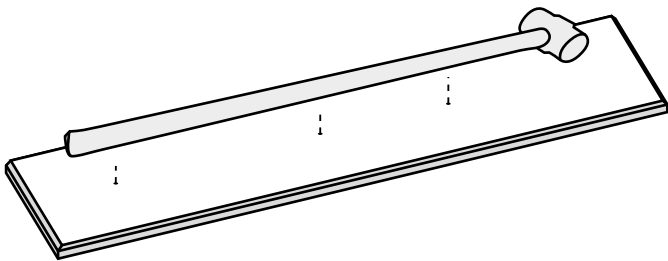

2

Center the sledgehammer horizontally across the plaque. Align the screws on the center line of the handle. Push down on the handle to dimple the sledgehammer handle with the screw points.

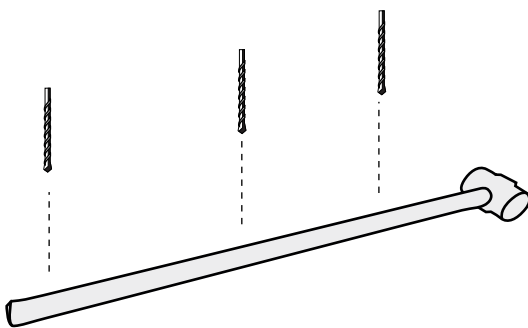

3

Drill pilot holes at these dimple marks. **Be careful not to drill all the way through the handle.**

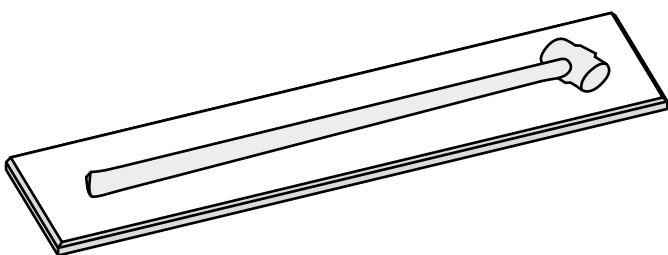

4

Place the sledgehammer onto the plaque, matching the screw points to the correct pilot holes, and then tighten the screws into the sledgehammer handle from the back of the plaque.