

NOZZLE CHART	
NOZZLE ID	NPT SIZE
N1	1/4
N2	3/4
N3	2

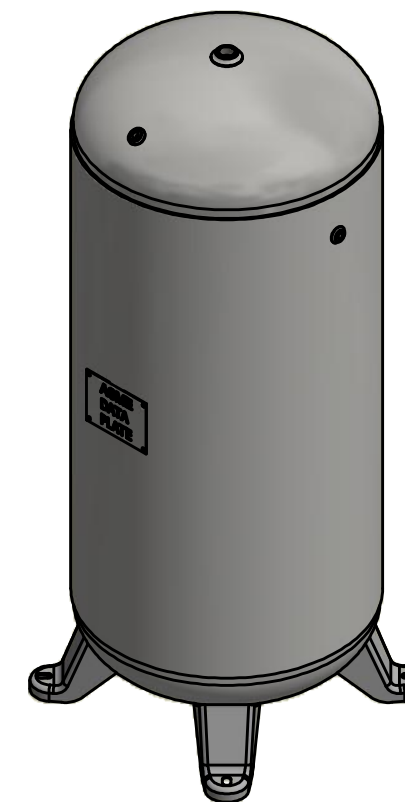
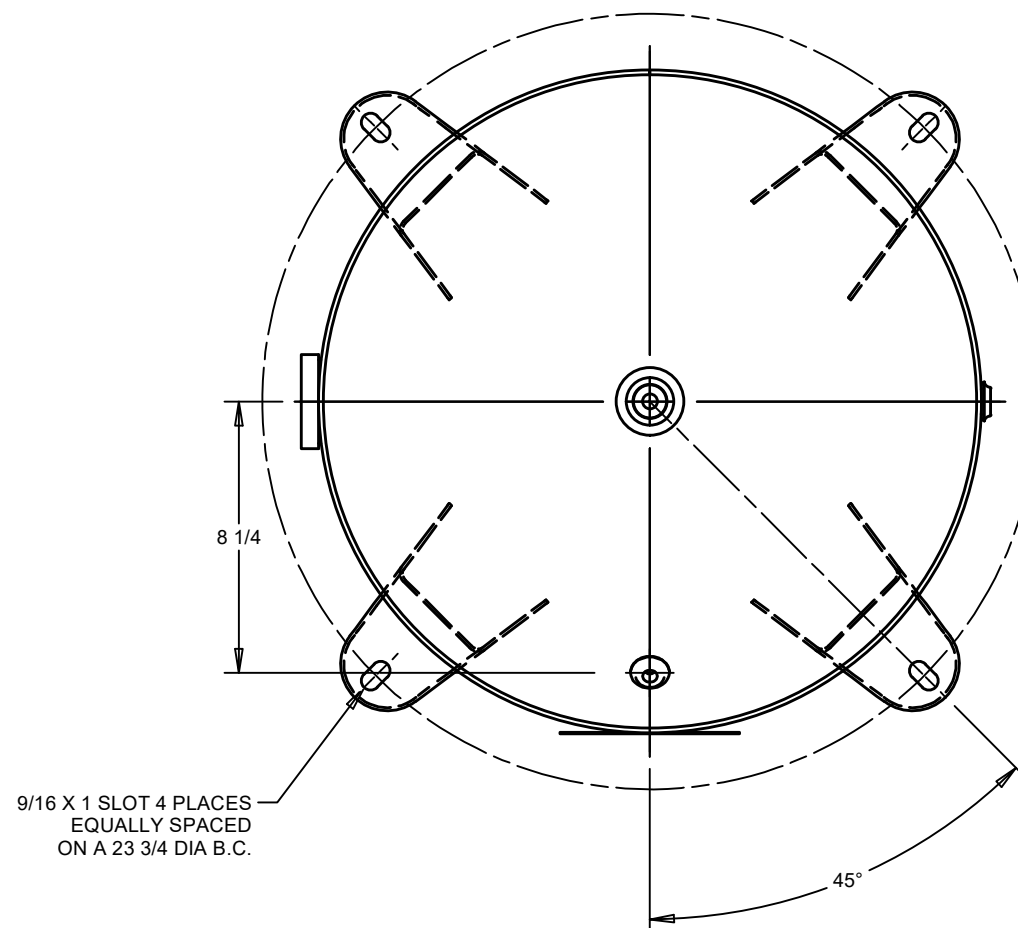
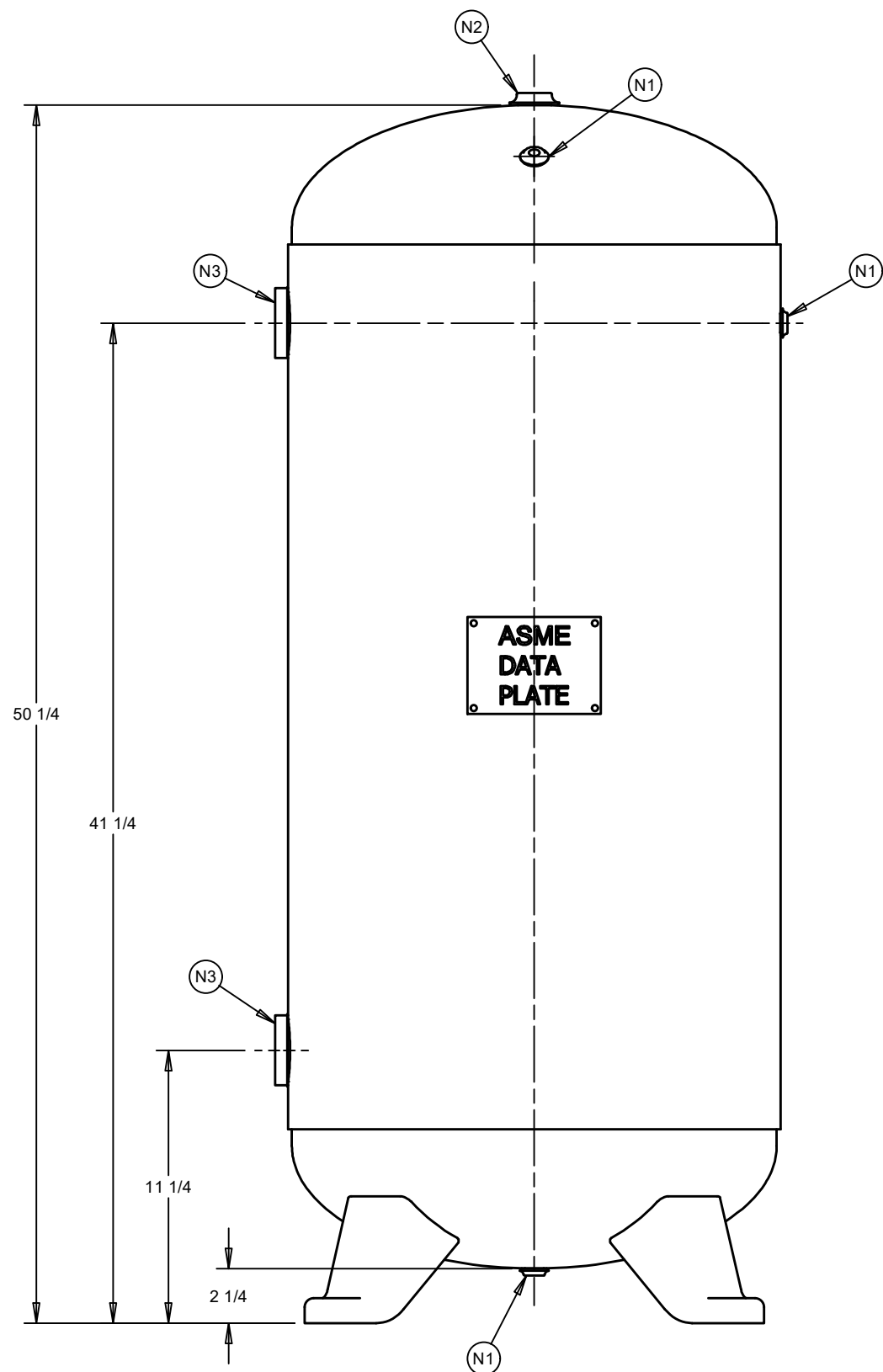

DESIGN INFORMATION	
SPECIFICATION	VALUE
DIAMETER O.D./I.D.	20 I.D.
MAWP	200 PSI AT 400°F
MDMT	-20°F AT 200 PSI
CAPACITY	APPROX 60 GALLONS
SHIPPING WEIGHT	148 LBS
CRN	M3329.5C

(BUILT IN ACCORDANCE WITH LATEST EDITION OF SECTION VIII DIV 1 ASME CODE)

THIS DRAWING & SPECIFICATIONS ARE PROPERTY OF SPVG AND MAY NOT BE COPIED, REPRODUCED, OR USED IN WHOLE OR PART, AS A BASIS FOR DESIGN MANUFACTURE OR SALE WITHOUT PRIOR PERMISSION FROM SPVG.

REV	DESCRIPTION	BY	DATE
C13	ISSUED		

TITLE VERTICAL AIR RECEIVER					
CUSTOMER STOCK		DRAWN KAT 9/1/2016	CHECKED DMM 9/19/2016	DRAWING NO A10043	REV C13
TYPE ASME		SIZE: B		SHEET 1 OF 1	