

# 120V

## COB NEON ROPE LIGHTS INSTRUCTIONS

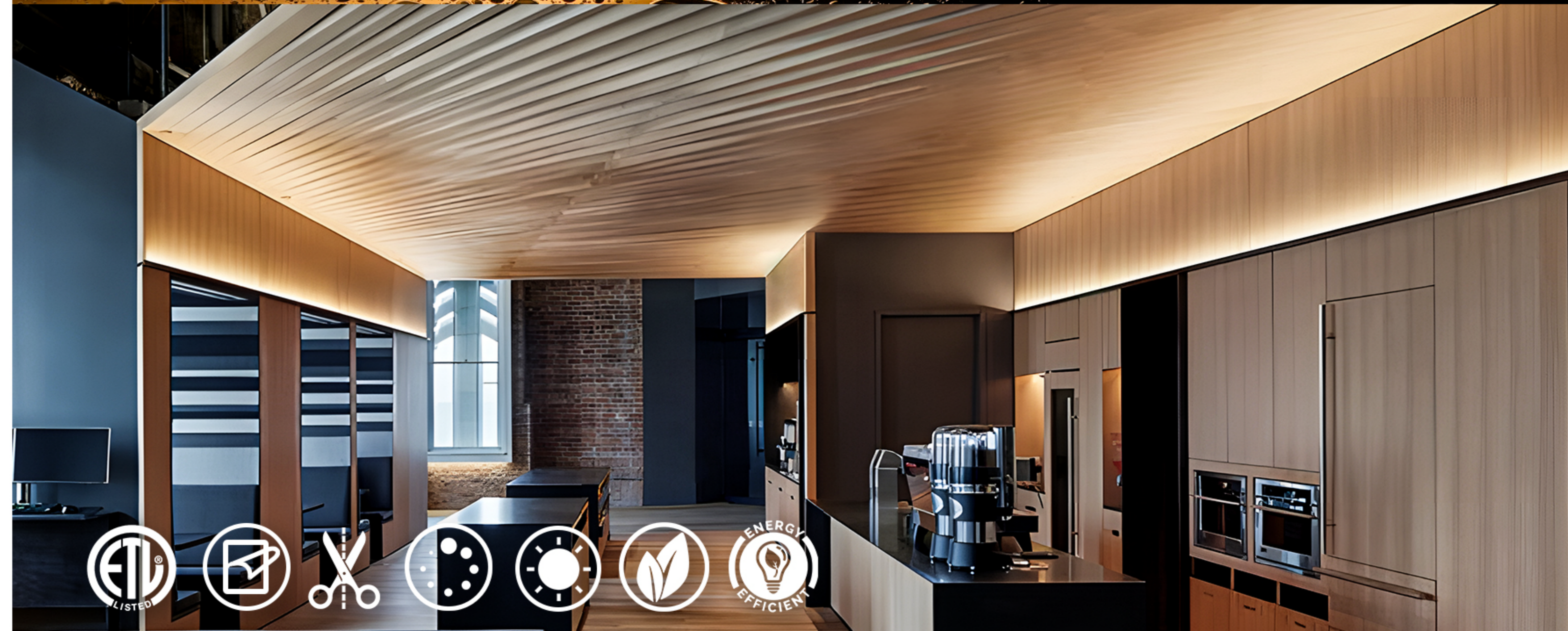



# CONTENTS

<b>DISCLAIMER</b>	<b>01</b>	<b>CUTTING INSTRUCTIONS</b>	<b>04</b>
<b>WARRANTY</b>	<b>01</b>	<b>POWERING INSTRUCTIONS</b>	<b>05</b>
<b>WARNING</b>	<b>02</b>	<b>SPLICING INSTRUCTIONS</b>	<b>06</b>
<b>SPECIFICATIONS</b>	<b>02</b>	<b>WATERPROOFING INSTRUCTIONS</b>	<b>07</b>
<b>ACCESSORIES</b>	<b>03</b>	<b>TROUBLESHOOTING</b>	<b>08</b>



## DISCLAIMER

Dear customer, these instructions are suggested installation procedures only, they do not constitute professional installation and may not necessarily meet all electrical requirements in your state. Please be reminded that our products covered by our ETL report are not intended to be field cutting or splicing. GZBtech assume no liabilities occur from improper installation including incorrect cutting, splicing and damaged waterproof insulation etc.

## WARRANTY

All of our products are warranted against defects in materials and workmanship for a period of one year from the date of original purchase. We provide 1 month hassle-free full refund, 6 months money back or free replacement and 12 months limited warranty.



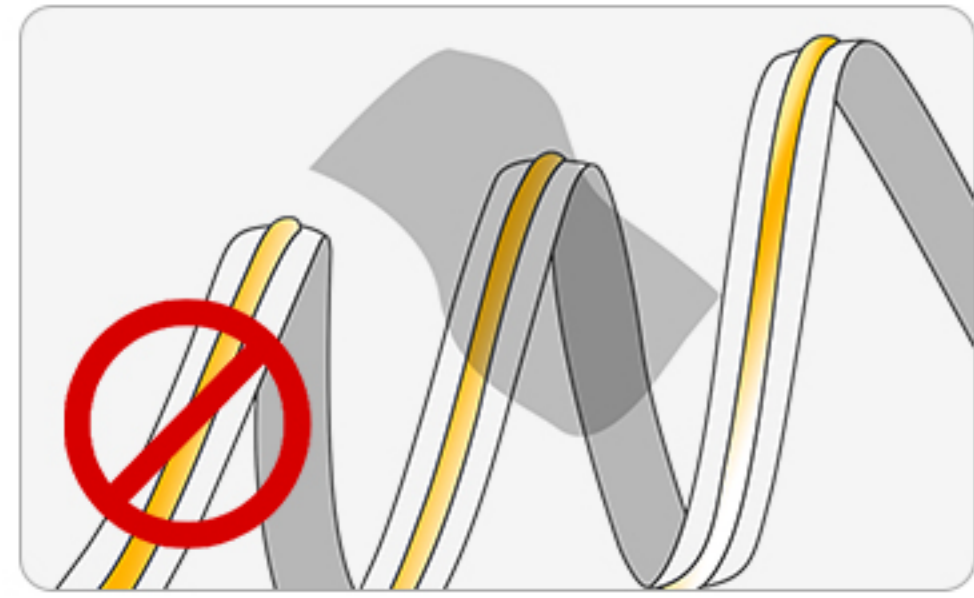

1. Do not cover this product as the covering may cause the light to overheat and melt or ignite.

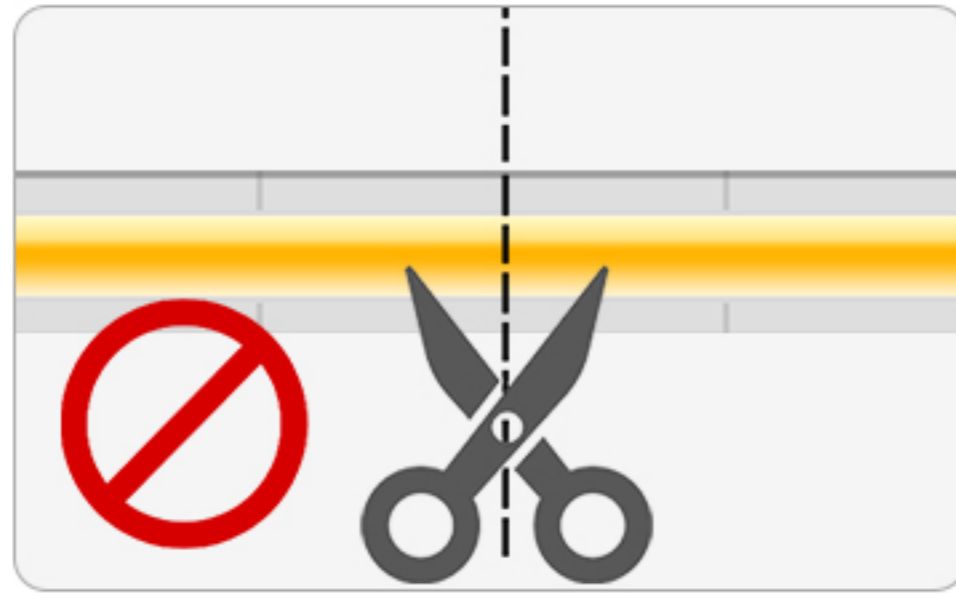

2. Do not cut the light anywhere other than the designated cutting mark.



3. Unroll the light before lighting it up. Or else it might melt the rope light and even cause a fire.

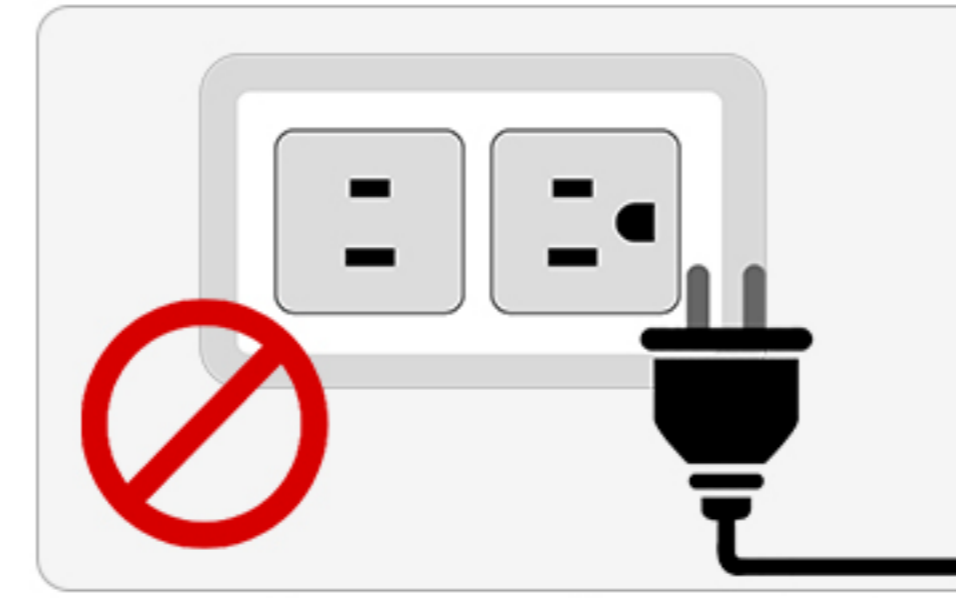

4. Unplug the light before installing or replacing fuses.

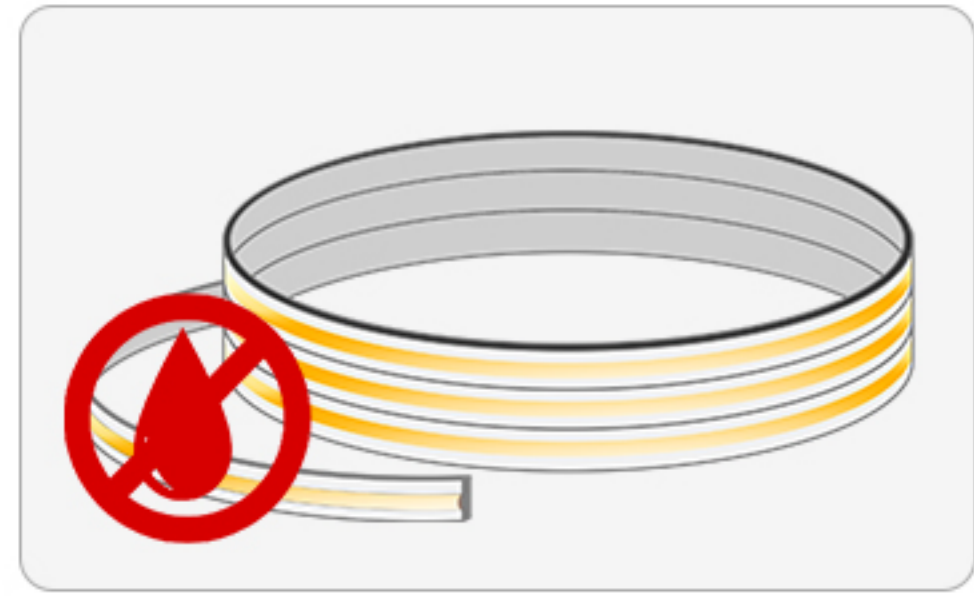

5. Do not submerge the light in liquids. Connections are non-waterproof yet. Keep all connections away from water and moisture to prevent circuit damage which can lead to fires.

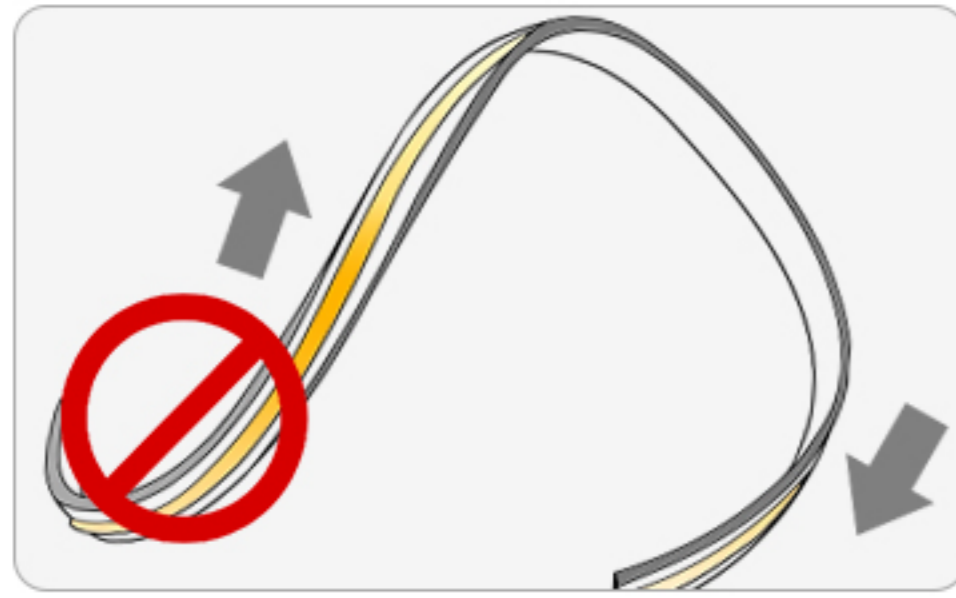

6. Do not pull on or stretch rope light as this will damage the inner wires, causing sections to fail.

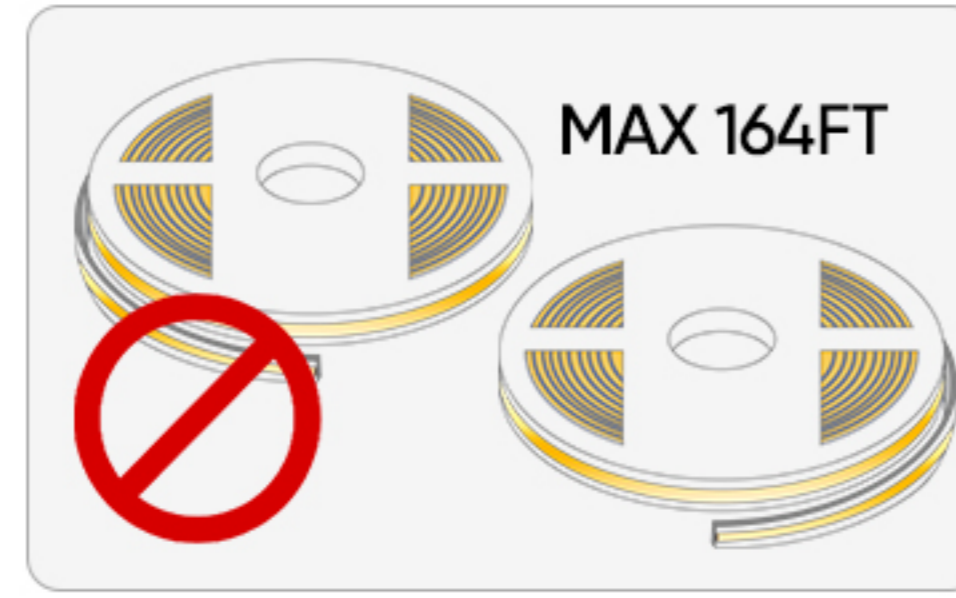

7. Do not connect more than 164ft per power feed to avoid overloading.

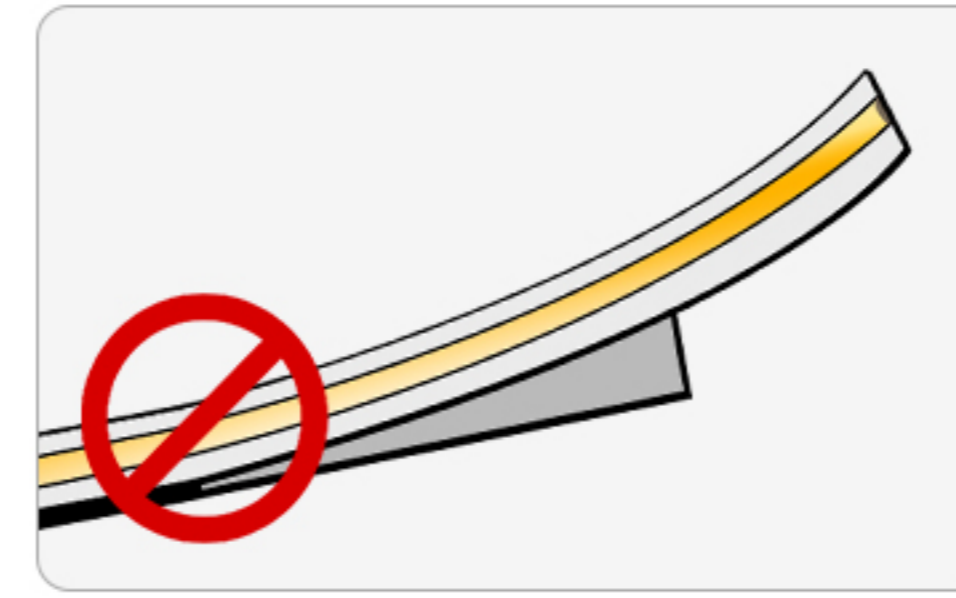

8. Do not mount or support the light in a manner that can damage the outer jacket or cord insulation. Inspect periodically.

**Power Cord with Fast Connector**

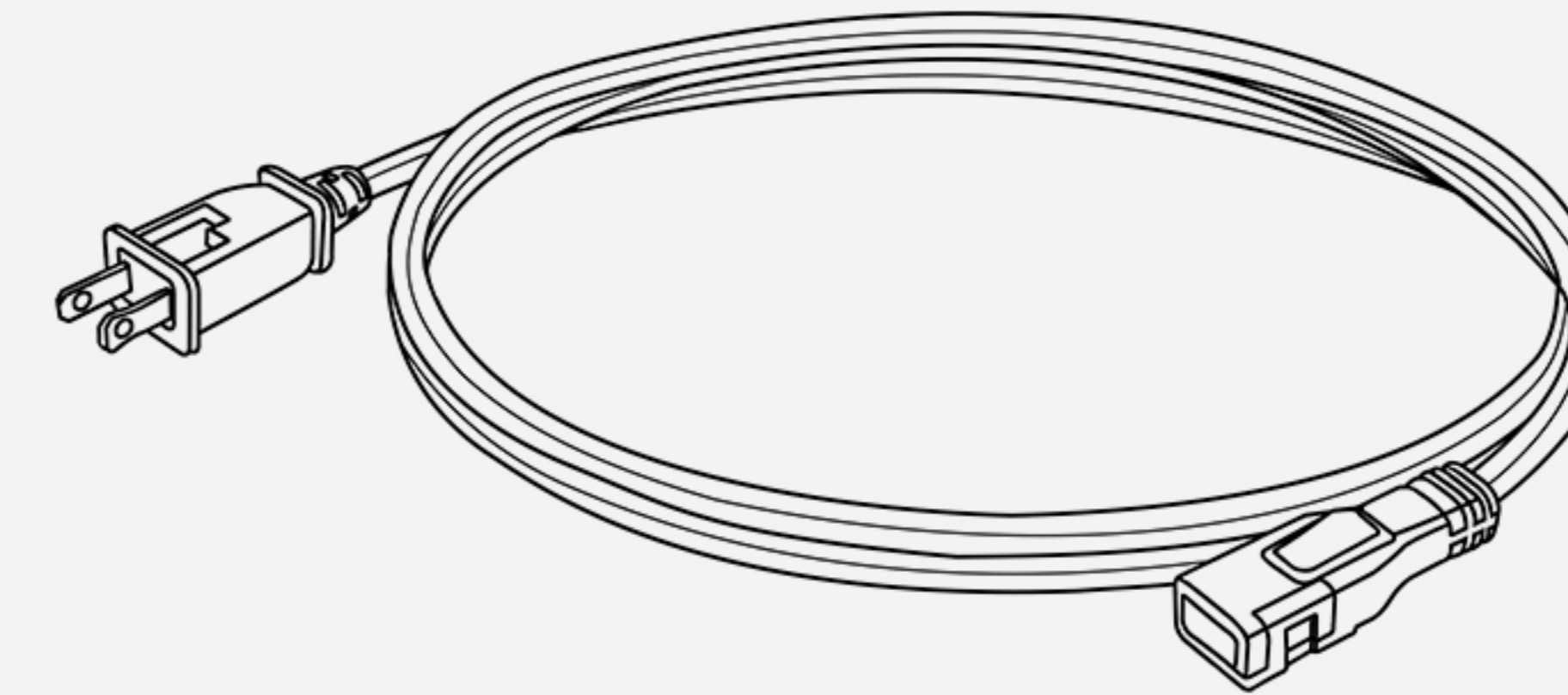

To power new runs of rope lights.

**Dimmer and Remote**

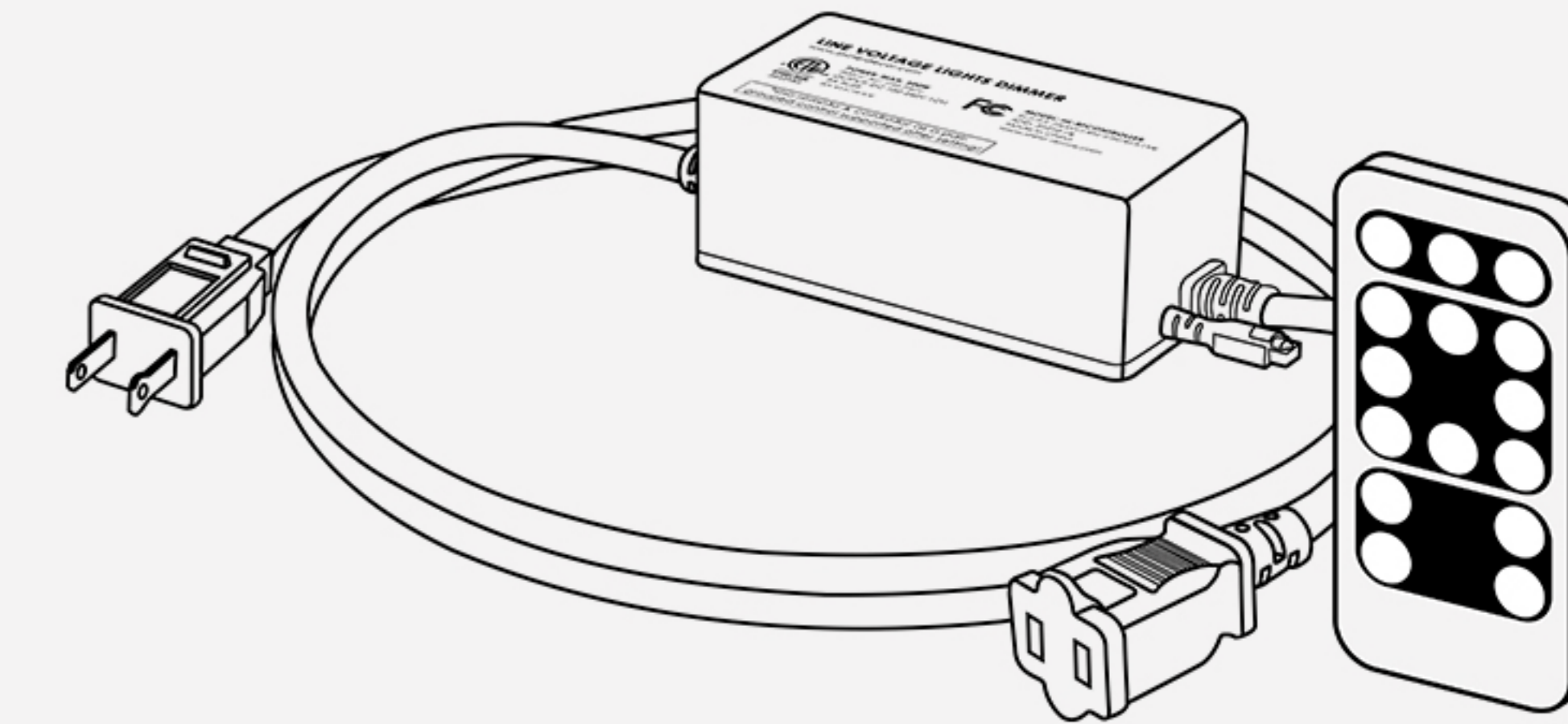

To decrease or increase the brightness

**Splice Connector**

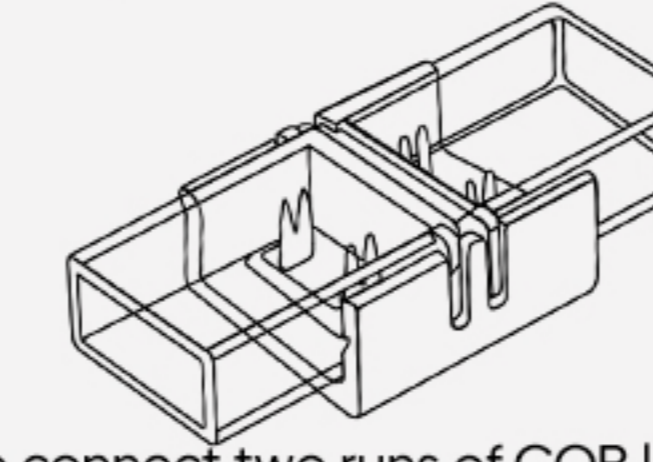

To connect two runs of COB lights together.

**Connecor Wire**

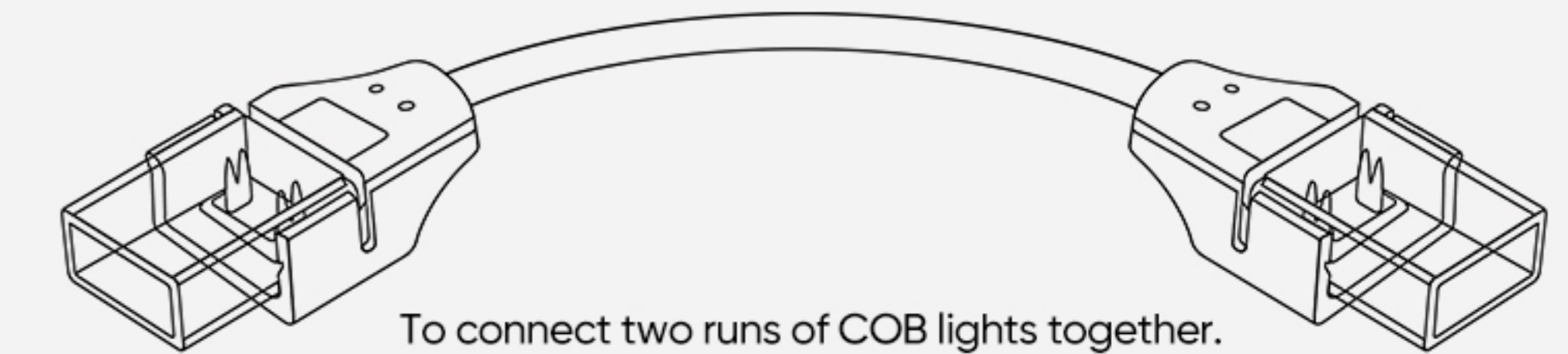

To connect two runs of COB lights together.

**Plastic Mounting Clips and Screws**

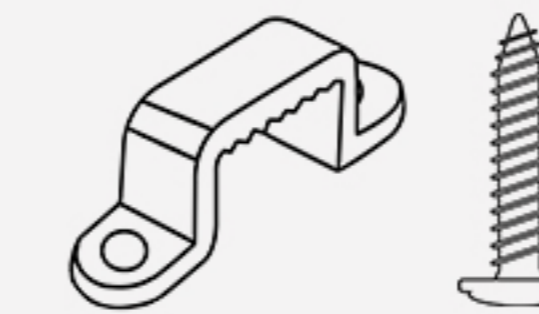

To secure rope light in place

**Silicon Glue**

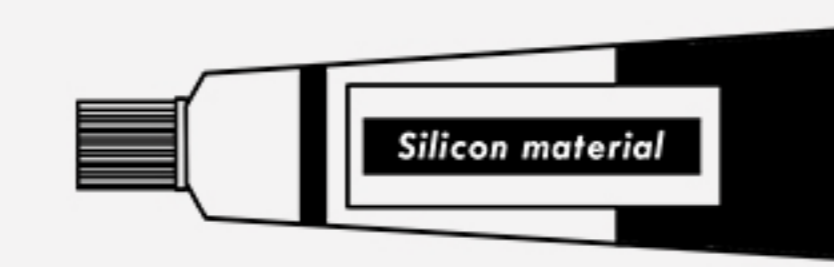

To seal all connectors and end caps.

**End Cap**

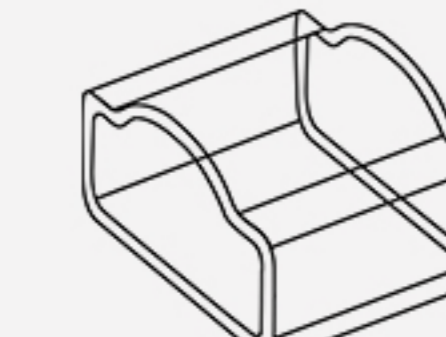

To protect exposed ends of the new cut runs.

**Heat Shrink Tube**

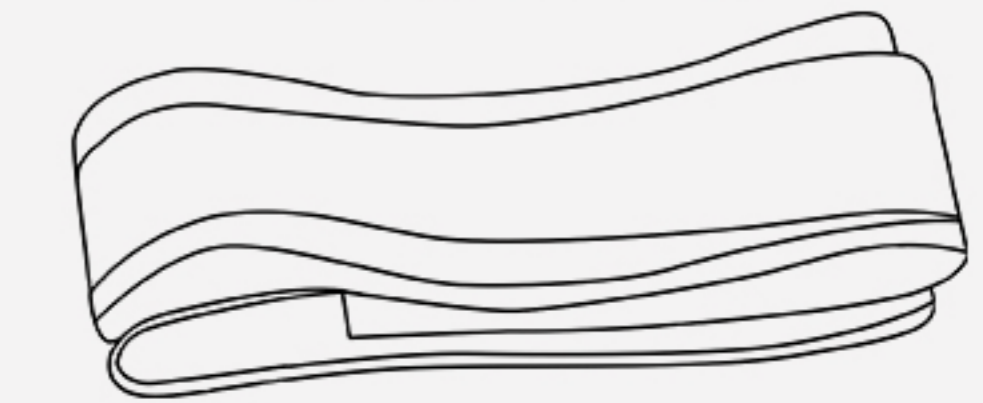

To protect all connections against ingress of dust and water.

**Aluminum Channel**



For straight mounting and better heat dissipation.

**SPECIFICATIONS**

<b>Voltage</b>	120V	<b>LED Type</b>	COB
<b>Power Consumption</b>	10W/M	<b>Cutting Interval</b>	4.5CM/1.79IN
<b>Max. Run Length</b>	50M/164FT	<b>IP Rating</b>	IP65 (non-submersible)
<b>LED Density</b>	286LED/M	<b>Application</b>	Task, Commercial Lighting



## IMPORTANT NOTES:

Although COB rope lights can be cut at designated cut mark. We do not recommend cutting for the following reasons:

1. Cutting rope lights voids any certification the product have had in it's pre-modified state.
2. Cutting or damaging outer tubing can cause an electrical/ fire hazard.
3. Cutting anywhere besides cut marks will damage that section of rope light and cause it to fail.

However, we still provide step-by-step guidance on how to safely cut rope light without damaging it and making it work for your specific needs. Please follow these steps as strictly as possible.

1. Disconnect power before cutting.
2. Measure the desired length for your application, COB lights is cuttable at every 4.5 centimeter or 1.79inches. There will be marks indicating where to cut the rope light. Take sharp scissors or utility knife, line it perpendicularly and cut exactly at the mark.
3. Attach end cap to the end of light strip.
4. Test the light by lighting it up.

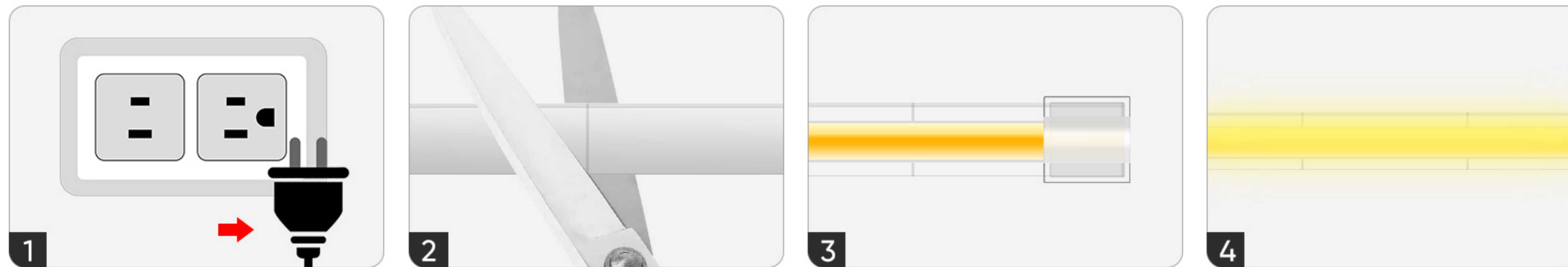

## Important Notes:

1. This connection is only suitable for non-waterproof strips.
2. When you cover it, you will probably end up covering one or two lamp beads. This can cause dark areas on the strips.
3. Due to it being clamped inside, the external tension is not enough. The connection could fall away after long-term use.

1. Disconnect power first.
2. Open the lid of the weld-free buckle on power cord.
3. Peel off about an inch of the light strip.
4. Snap the light into the middle position of the buckle.
5. Close the lid firmly so that the copper thorns inside the buckle pierce the light strip.
6. Attach end cap to the end of light strip.
7. Check and secure all connections. Test the light by lighting it up.

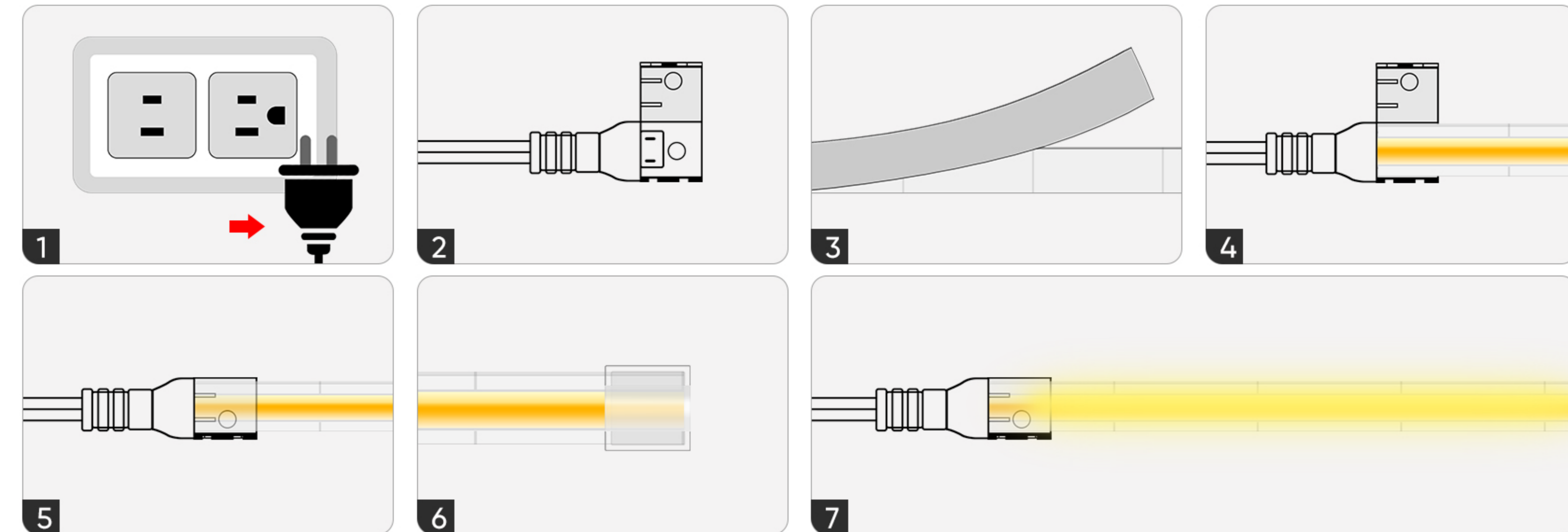



## Important Notes:

1. This connection is only suitable for non-waterproof strips.
2. When you cover it, you will probably end up covering one or two lamp beads. This can cause dark areas on the strips.
3. Due to it being clamped inside, the external tension is not enough. The connection could fall away after long-term use.

1. Disconnect power first.
2. Peel off about an inch of the light strip.
3. Insert neon lights into the clear plastic case. Make sure the light goes in the right direction as depicted in the picture.
4. Press the light with case into the middle position of the buckle. Press the case firmly so that the copper thorns inside the buckle pierce the light strip.
5. Repeat steps above on the other side.
6. Check and secure all connections. Test the light by lighting it up.

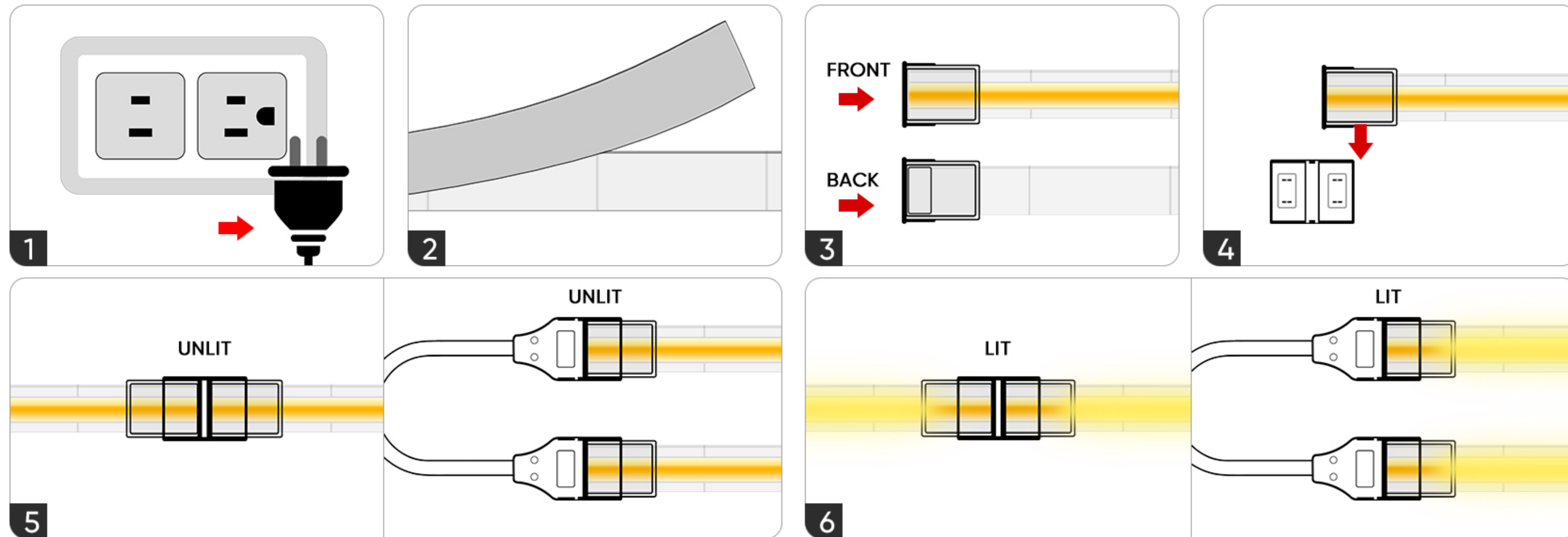

## Important Note:

All connections, power cord connection part, end caps, splice connection part are non-waterproof and must be properly resealed to prevent moisture intrusion which can cause dangerous short circuiting and even lead to fires.



1. Disconnect power first.
2. Cut about 4 inches of heat shrink tube, and then slide it over the power cord.
3. Waterproof connections by applying silicone adhesive liberally into the inside and outside of the connected area. Gently press out any bubbles and make sure to wipe out excess adhesive, let it dry for 24 hours.
4. Slide the heat shrink tube over the connected area, then use a heat gun to heat up the tubing to create the seal.
5. To create an authentic watertight seal, you need to further waterproof it by wrapping more tubing around connections in an overlapping spiral fashion, then use a heat gun to repeat these steps. Make sure the end cap get waterproofed too.

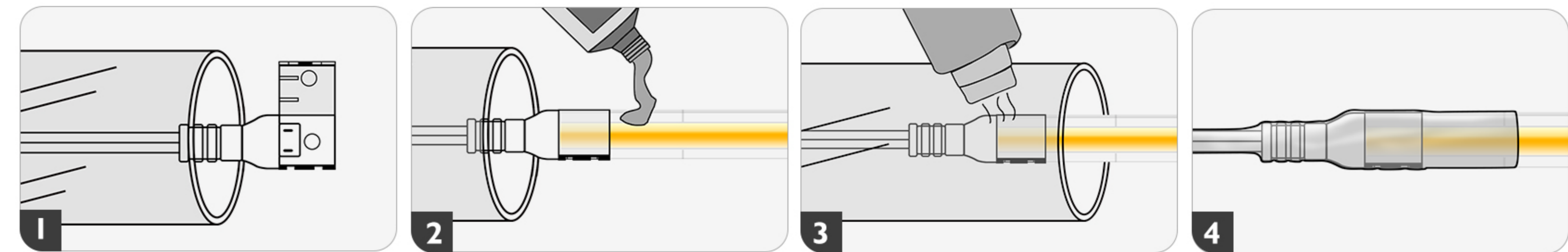



<b>Problem</b>	<b>Possible Cause</b>	<b>Solution</b>
<b>The entire light will not illuminate</b>	Incorrect power source	Ensure the light is plugged into an 120VAC outlet and the power is on.
	Loose connection, Solution	Re-check the connections. Due to it being clamped inside, the external tension is not enough. The connection could fall away after long-term use.
	Mixed polarity	Check the right polarity according to the POWERING INSTRUCTIONS.
	Blown fuse	Check if the inline fuse on the plug has blown, fuses normally blow out when they short circuit caused by water intrusion or damaged wiring connections.
<b>The light has sections that will not illuminate</b>	Manufacturing flaw or mechanical damage during shipping	Check if the sections do not light up when the light first arrives.
	Incorrect bending during installation	Do not fold or stretch the rope lights. Do not bend the light to sharp angles or make repeated and continuous bending as this may damage circuit traces during installation.



**Questions? Problems? Bulk order discount?**  
Instantly chat to your Customer Service Representative

on [www.gzbtech.com](http://www.gzbtech.com) or email us at [info@gzbtech.com](mailto:info@gzbtech.com)  
**we'd love to hear from you!**