

ENDEAVOR

9000I-HSH MULTI-PURPOSE EXTRACTOR

OWNER'S / OPERATOR'S MANUAL



PROUDLY DESIGNED AND MANUFACTURED BY

EDIC



Revision 1
6-5-17
For commercial use only

TABLE OF CONTENTS

RECEIVING YOUR EQUIPMENT.....	3
WARNINGS AND SAFETY.....	3, 4
ELECTRICAL INFORMATION.....	4,5
MAINTENANCE.....	5
MACHINE LAYOUT.....	6
CONTROL PANEL OVERVIEW.....	7
POWER CORD AND CIRCUIT LOCATOR OPERATION.....	8
CONNECTING VACUUM AND SOLUTION HOSE.....	8
RECOVERY TANK FILTERS.....	9
AUTO-FILL/ AUTO-DUMP.....	10
PRIMING THE PUMP.....	10
ADJUSTING PUMP PRESSURE.....	11
OPERATING INSTRUCTIONS FOR HEATER.....	11
CLEANING CARPET.....	12
CLEANING TILE AND GROUT.....	12
MOUNTING THE 991RSS SYSTEM (OPTIONAL).....	12
SETUP OF 991RSS SYSTEM (OPTIONAL).....	13,15
USING A 9000AC SPRAYER (OPTIONAL).....	15
OPERATING INSTRUCTIONS FOR HARD SURFACE CLEANING.....	15,16
SOLUTION TANK BREAKDOWN.....	17,18
RECOVERY TANK BREAKDOWN.....	19-21
BASE BREAKDOWN.....	22-24



UNPACKING YOUR NEW ENDEAVOR:

When your equipment is delivered, check the carton carefully for signs of rough handling. If the ENDEAVOR is damaged, notify the carrier immediately and request an inspection. Be sure to keep the carton, packing inserts, packing lists and carrier's receipt until the inspector has verified your claim.

EDIC's liability ceases when the carrier picks up the shipment. However, our customer service staff will be happy to furnish any information needed in connection with the claim and will attempt to expedite a resolution.

PLEASE READ BEFORE OPERATING YOUR NEW ENDEAVOR:

Read the manual carefully and completely before attempting to operate the unit. This manual has important information for the use and safe operation of the machine. Keep this manual handy at all times.

This equipment has been engineered and manufactured to provide excellent performance and service. To ensure that your equipment will continue to perform as intended:

- Maintain equipment regularly- following the suggested maintenance schedule provided.
- Use only original EDIC parts when servicing.
- Operate equipment with care.

All information and specifications printed in the manual are current at the time of printing; however because of EDIC's policy of continual product development, we reserve the right to make changes at any time without notice.

FAILURE TO COMPLY WITH THE FOLLOWING WARNINGS AND INSTRUCTIONS MAY POSE A HAZARD AND WILL VOID THE WARRANTY.

WARNING:

- This is not a toy. Keep away from children.
- Always read and understand your chemical's MSDS (Material Safety Data Sheet) before use.
- This extractor is not designed to handle or use combustible/volatile substances such as gasoline or kerosene, in, on, or near the equipment. The use of such materials will cause extreme hazardous condition.
- Make sure the extractor has all water filters in place.

- Do not allow high pressure spray stream to remain in one fixed location as surface damage may occur.
- Check that all spray nozzles are securely fastened. Loose nozzles could be ejected from equipment at high speeds.
- Prevent burns by wearing gloves or using a barrier to remove hot quick disconnects.
- Use caution with ejected liquid or chemicals. High pressures and temperatures could be hazardous to nearby people or surroundings.
- All servicing of EDIC equipment should be performed only by EDIC authorized service centers.
- Do not use replacement parts other than those specified in the parts list. Equipment performance could be affected if substitutions are made. Use of no-EDIC parts will void the warranty.
- When using an extension cord, use only a 3-prong conductor grounding cord- 12 gauge wire or heavier. Do not use extension cords longer than 25FT.
- To avoid electric shock, do not expose the unit to rain or snow. Store indoors in a heated location only. Do not expose machine to freezing temperatures.
- Do not use the machine for dry vacuuming.
- Use defoamer at all times to prevent damage to the vacuum motor.
- Do not use water in excess of 130°F (54°C) in the solution tank
- To prevent seal damage and chemical build-up to the pump system, run clean water through the solution lines after each day's use.
- Use only commercially available carpet cleaning solutions and defoamer intended for use with machines of this type. Do not use dyes, bleaches, ammonia, or other additives.
- The use of powdered cleaning solution, if not diluted properly, may result in damage to the pump. Powdered chemical is not recommended. If powdered chemicals are used, premix in a separate container before placing in the solution tank. Any damage resulting from powdered chemical will void the warranty.
- Do not pull machine by the power cord. Always unplug by grabbing the plug and pulling, do not unplug by pulling the power cord.
- Periodically inspect cord for damage. Do not use damaged cords. Connect only to properly grounded outlets.
- Keep hair, fingers, loose clothing, and body parts away from moving parts and openings.
- Turn off all controls before disconnecting machine
- Do not use without vacuum pre-filter bag in place.

Servicing:

In the event that your ENDEAVOR requires service, please contact EDIC at: 800-338-3342 or email info@edic-usa.com

Do not attempt repairs yourself. EDIC will assist you in locating an independent service contractor.

GROUNDING INSTRUCTIONS:

This piece of equipment must be grounded. Should an electrical malfunction occur, grounding provides a path of least resistance for electrical current- reducing the risk of electric shock. This piece of equipment is furnished with a cord that has a grounding conductor and grounding plug. The grounded plug must only be plugged into an appropriate outlet that is properly installed and grounded in accordance with all local codes and ordinances.

WARNING:

Connecting the equipment to an improperly grounded outlet can result in an increased risk of electric shock. A qualified electrician should be consulted if you are unsure that the outlet is properly grounded. Do not modify the plug provided with the equipment. If it will not fit the outlet, have a proper outlet installed by a qualified electrician. Replace the plug if the grounding pin is damaged or broken.

This appliance is designed for use on a 120-volt circuit. The Green (or Green/Yellow) wire in the cord is the grounding wire. When replacing a plug, this wire must be attached to the grounding pin only.

Extension cords connected to this machine should be 12 gauge, three-wire cords with three-prong plugs and outlets. DO NOT use extension cords more than 25 feet (7.6 m) long.

GFCI CORD FUNCTION:

The ENDEAVOR's power cords are equipped with a built in GFCI (Ground Fault Circuit Interrupter). The GFCI function is automatic and will not be active under normal operating conditions.

A GFCI works by monitoring the amount of current that

is flowing from hot to neutral. If the GFCI senses an imbalance in that flow, such as a ground leak, it will disable (interrupt) the electrical system to eliminate dangerous operating conditions. If the GFCI trips due to a temporary incident, you may restore function by pressing the button on the GFCI box marked Reset "RESET" button on the GFCI box.

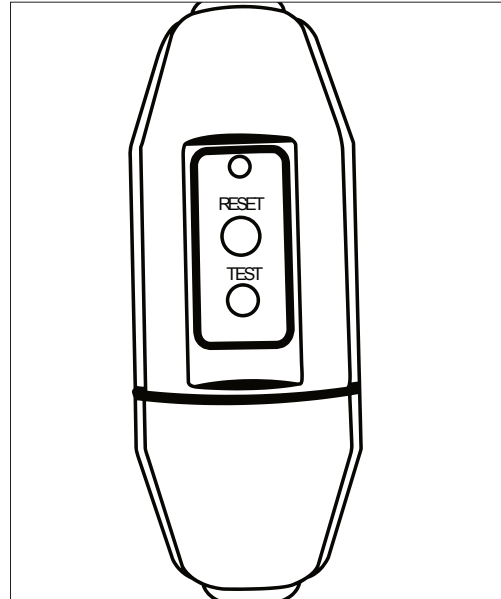

If a GFCI continues to trip after resetting, it indicates an unsafe operating condition is present and it is best to take it to an authorized repair location for servicing.

Possible causes and solutions are:

- Your equipment has become wet and moisture has come in contact with the electrical system. **Take unit to an authorized repair location for servicing.**
- Your machine is submerged in liquid. **If it is safe to do so, remove the equipment and take unit to an authorized repair location for servicing.**
- There is damage to the power cord. **Replace the power cord immediately with the correct spec cord.**
- The wall plug or cord plug may be wet or in contact with water. **Using thick rubber gloves, unplug the cord from the wall.**
- A leak in your machine's plumbing may be wetting the internal electrical components. **Take the unit to an authorized repair location for servicing.**
- There is a loose or faulty electrical connection somewhere in your equipment. **Take the unit to an authorized repair location for servicing.**



GFCI MAINTENANCE:

Although the GFCI function works on its own, it is necessary to test for proper function of your GFCI periodically. To do this:

1. Plug your equipment to an appropriate wall plug.
2. Press the “TEST” button on the GFCI panel on the cord.
3. Turn on the switches for “PUMP” and “VACUUM” (located on the switch panel on the front of the machine).

If your motors turn on, then the GFCI is NOT working properly- do not use the equipment until this function has been repaired. Take the machine to an authorized repair location.

If neither motor powers on after pressing the “TEST” button then the GFCI is working properly.

Press the “RESET” button on the GFCI and the ENDEAVOR will be fully functional again.

NOTE: THE GFCI MUST BE RESET ANY TIME THE CORD IS UNPLUGGED. WHEN THE GFCI IS OPERATING PROPERLY, THE RED INDICATOR LIGHT WILL BE ON.

CORD STORAGE:

While not in use, store cords in a clean dry area. Wind cord carefully to prevent kinking. Cord should be completely unwound during operation.

CORD SAFETY

- Do not leave appliance when plugged in. Unplug from outlet when not in use and before servicing
- Do not use with damaged cord or plug. If appliance is not working as it should, has been dropped, damaged, left outdoors, or dropped into water, return to service center for inspection and repair.
- Do not pull or carry by cord, use cord as handle, close a door on cord, or pull cord around sharp edges or corners. Do not run over cord.
- Keep cord away from heated surfaces.
- Do not unplug by pulling cord. To unplug, grasp the plug, not the cord.
- Do not handle plug or appliance with wet hands.
- This equipment should be stored indoors and not exposed to rain.

MAINTENANCE OF THE ENDEAVOR:

The ENDEAVOR has been engineered and built to require minimum maintenance. However, careful attention to these maintenance instructions will help extend the life of your equipment.

DAILY:

- Keep the ENDEAVOR clean inside and out.
- Pour clean hot water (MAX 130°F/ 57°C) into the solution tank of your ENDEAVOR extractor. Turn the pump on and flush the entire system through the spray nozzles for 1 minute to prevent chemical build-up.
- Run the vacuum motor for 30 seconds before putting away the ENDEAVOR.
- Rinse out the Recovery tank.
- Clean the vacuum intake pre-filter bag and the pump-out filter.

MONTHLY:

- Use an extractor flushing agent through the machine's plumbing to dissolve mineral and chemical build up.
- Quick disconnects, wheels, casters, and regulators can be lubricated with an all-purpose silicone lubricant spray.
- Check and clean the filters in the solution tank.

PUMP WEAR AND TEAR MAINTENANCE:

After 500 hours, replace the following pump head components:

- KIT A, PLUNGER AND SEALS: PART #G13333-1
- KIT B, VALVE SET: PART #G13333-2
- CAM BEARING: PART #G13682

After 1500 hours, replace the following pump head components:

- KIT A, PLUNGER AND SEALS: PART #G13333-1
- CAM BEARING: PART #G13682

After 3000 hours, replace the following pump head components:

- KIT B, VALVE SET: PART #G13333-2

Contact EDIC for PUMP maintenance instructions.

ENDEAVOR OVERVIEW

1. Handle: Used to position and maneuver the machine.
2. Recovery tank and access point. Lid can be removed for cleaning of recovery tank.
3. Accessory chemical feed mounting shoe.
4. Switch/ Control panel.
5. Solution tank and access point.
6. Accessory management system: Secures 1 carpet wand or 1 REVOLUTION wand to the ENDEAVOR.
7. Grab handle and clam shell screw access point.
8. Rear caster wheels: Allow the machine to be placed on its back when loaded onto a vehicle.
9. Waste dump valve.
10. Auto-dump port: Connects to garden hose to dump waste water.
11. Auto-fill port: Connects to garden hose to fill solution tank.
12. Power cord receptacles.

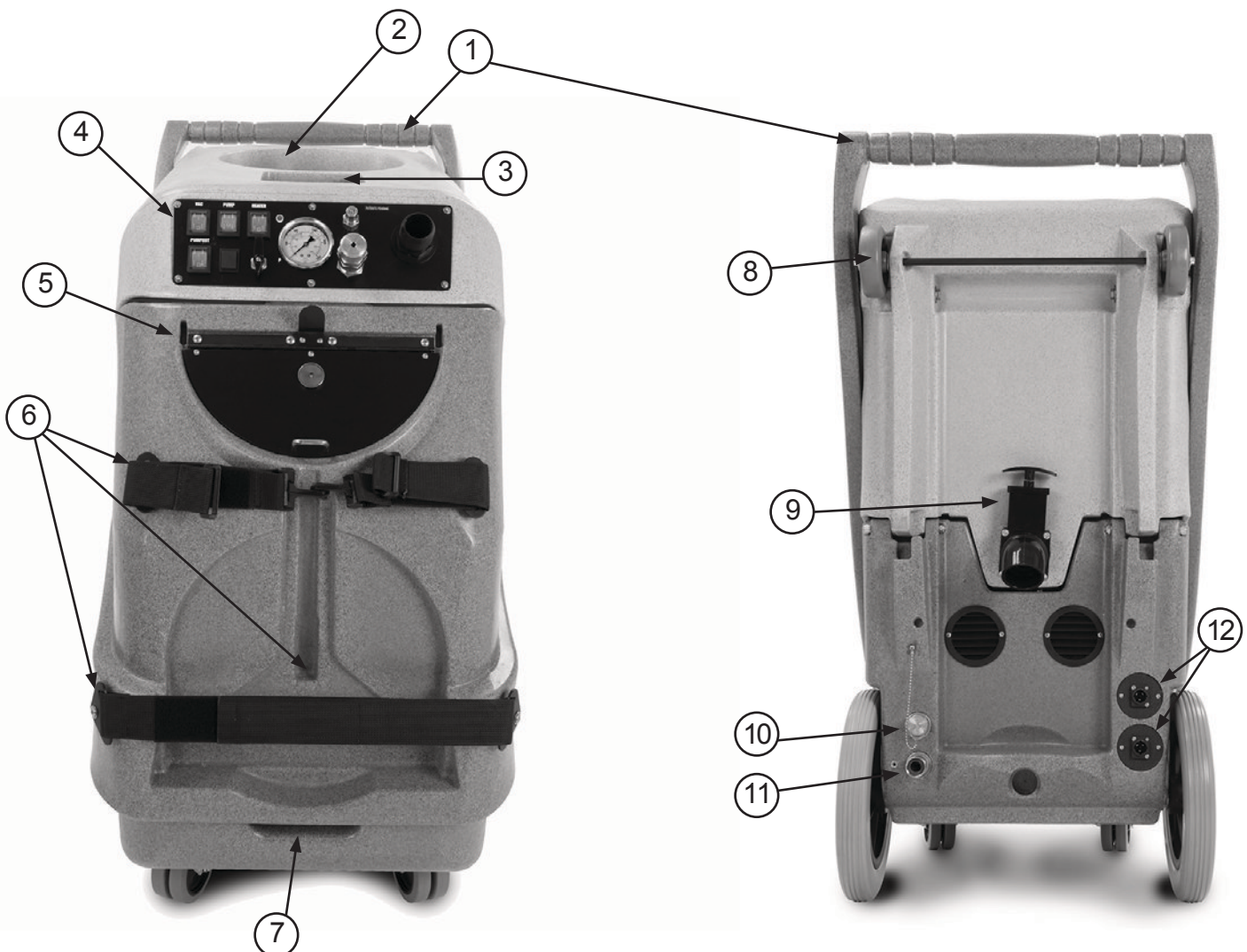

CONTROL PANEL OVERVIEW

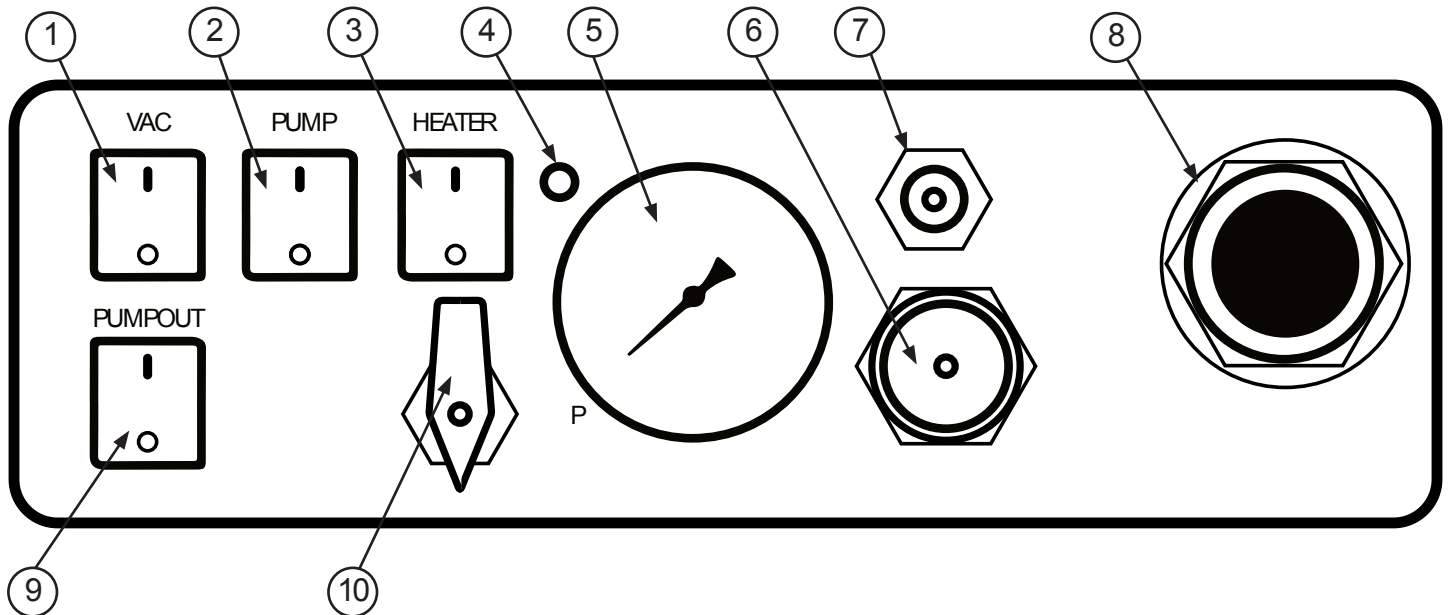

1. Vacuum power switch. "I" is on. "O" is off.
2. Pump Power switch. "I" is on. "O" is off.
3. Heater power switch. "I" is on. "O" is off.
4. Circuit locator confirmation light: Lights up green when both power cords are on two separate circuits.
5. Pressure gauge: Displays pump pressure.
6. Pressure regulator: Allows pressure to be adjusted by turning clockwise (raising pressure) or counter-clockwise (reducing pressure).
7. Solution line Q.D.: Allows solution line to be connected to the machine.
8. Vacuum hose inlet barb: Allows vacuum hose to be connected to the machine.
9. Pumpout power switch. "I" is on. "O" is off.
10. Priming/ pressure relief valve. Pointed to "P" is open. Pointed down is closed.

CONNECTING THE POWER CORDS:

The ENDEAVOR uses POWERCON twist lock connectors on the end of the GFCI powercords. These mate to the female receptacles on the body of the ENDEAVOR. The female receptacles are found on the bottom right hand side of the machine on the rear. See #12 on page 6.

To connect:

1. Take a powercon twist lock connector end and match the chuck on the connector to the keyway on the female chassis receptacle.
2. Insert the connector and turn in a clockwise motion. A click will be heard when the connector has engaged and is locked in place.

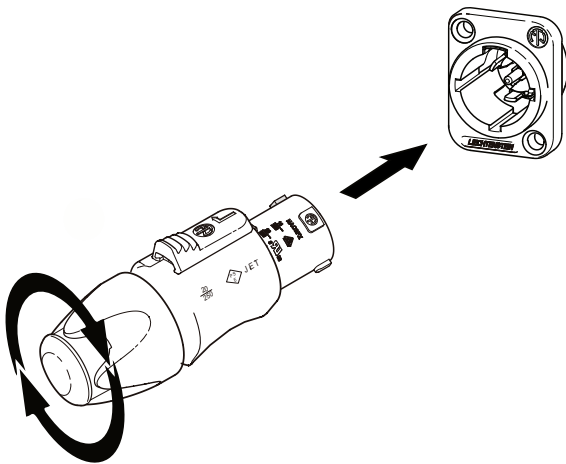

3. To disconnect, pull back on the sliding lock release then turn the connector in a counter-clockwise motion. Pull the connector out of the chassis receptacle.

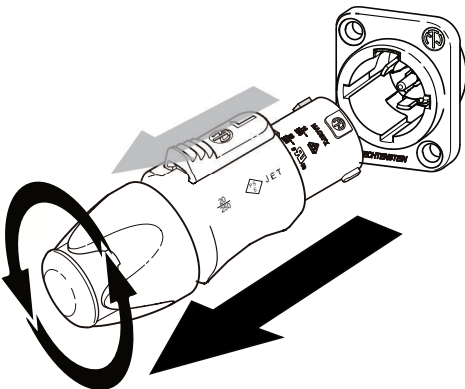

4. Connect the male wall plug end of the power cord to a wall socket with its own separate circuit.
5. Press the RESET button on the cord's GFCI box. When the red confirmation light on the GFCI box turns on, the machine is ready to use. For more information on the GFCI and its function, see pages 4 and 5.

USING THE CIRCUIT LOCATOR:

The ENDEAVOR has a built in circuit locator. When the unit is plugged into two separate circuits, the circuit locator confirmation light will turn on. The confirmation light is marked "CT" and is located on the control panel. See #4 on page 7.

1. Connect both power cords to machine.
2. Plug both male wall plug cord ends into two separate wall plugs.
3. Press the reset button on each GFCI plug.
4. The light marked "CT" will turn on if you are on two confirmed circuits. If you are in a very brightly lit environment, shield the "CT" light with your hands to better see the confirmation light.
5. If the "CT" light does not come on, try plugging into another circuit until you get a confirmation light.

NOTE: Do not ignore the circuit locator. Do not run both cords on one circuit. Doing so may overload the circuits and trip the circuit breaker.

CONNECTING SOLUTION AND VACUUM HOSES:

Hose connections for the solution line and the vacuum line can both be found on the front of the machine in the control panel. The control panel is #4 on page 6.

Solution hose: Connect the Q.D. on your solution hose to the Q.D. on the machine's control panel (#7 on page 7). Connect opposite end of the solution hose to your accessory.

Vacuum hose: Connect the cuff on your vacuum hose to the vacuum hose barb on the machine's control panel (#8 on page 7). Connect opposite end of the vacuum hose to your accessory. Make sure hose cuffs are pushed in securely.

RECOVERY TANK FILTERS:

VACUUM PRE-FILTER BAG:

The intake Pre-filter bag has been designed to catch larger debris before it enters the open area of the waste tank. This keeps the auto-dump intake filter from clogging too fast.



Locate the filter bag in the waste tank, press the cord release (circled above in white) and pull back to loosen the drawstrings. Remove all solids, rinse the bag out and place back into the tank. Tighten the cord release. Always remove the bag by loosening the cord, do not pull the elbow out. Check and clean bag during and after every job.

AUTO-DUMP INTAKE FILTER:

The auto-dump filter is located next to the vacuum intake stand pipe. The filter can be removed by turning counter-clockwise. Turn Clockwise to re-tighten. Check and clean filter during and after every job.



VACUUM INTAKE FILTER AND VACUUM SHUT OFF:

The vacuum intake filter houses the float ball which is in place to shut off airflow to the vacuum motor when there is too much fluid in the waste tank. This function keeps the vacuum motor from taking in fluids and getting damaged. Under normal operating conditions the mesh screen on the air filter should not get dirty. A dirty filter is a sign of over-filling or not using defoamer. To remove the filter cage, Pull down on the filter, in a pivoting motion. Clean as needed. Firmly press it back into place. If there is minor build up, you may use a towel to wipe off the surface of the filter.

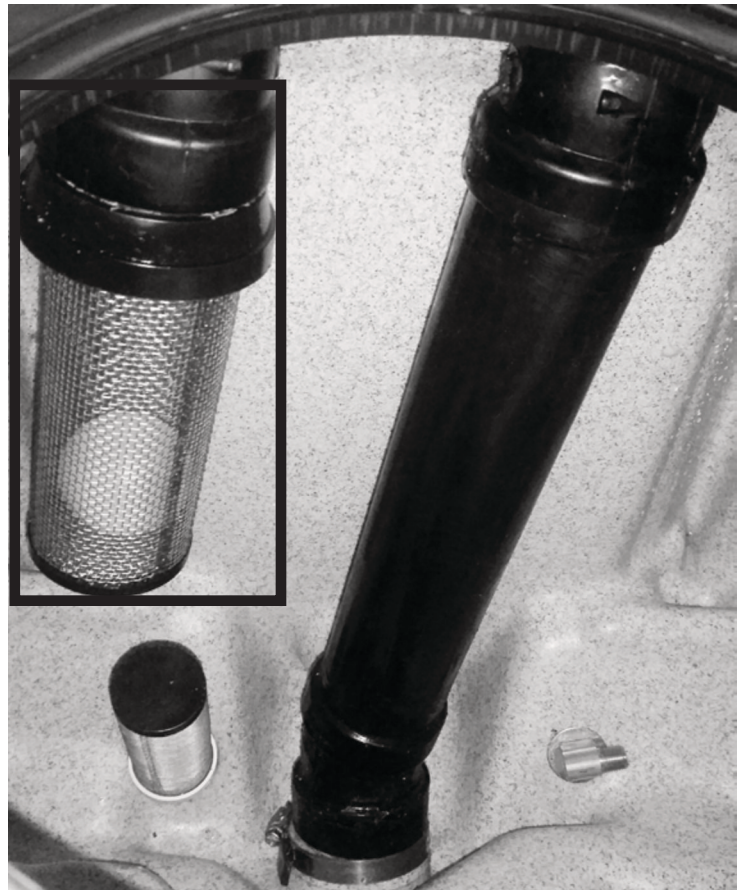

NOTE: Daily cleaning filters, are essential to preserving the proper function of the pump out feature. It is up to the operator to determine a proper cleaning schedule as workloads differ from job to job. It is advisable to inspect the filters throughout each job to gauge what an appropriate cleaning schedule would be.

UTILIZING AUTO-FILL & AUTO-DUMP:

This machine is equipped with the ability to self-regulate the levels of fluid in the solution tank and the recovery tank.

NOTE: To prevent flooding, periodically stop to monitor your solution tank and recovery tank levels to ensure that the Auto-Dump and Auto-Fill features are working properly.

Auto-Fill:

1. Connect a 3/4" garden hose to a faucet.
2. Connect opposite end of the garden hose to the female garden hose connection located on the rear bottom left of the machine. #11 on page 6.
3. Turn the water pressure on to about 1/4 to 1/2 of the full flow. Do not turn to full pressure.
4. Wait for the solution tank to fill and confirm it has stopped filling before walking away to begin your job.
5. The Auto-fill function is controlled by a float valve. Any obstruction of the float valve could lead to flooding or not filling at all. Check that the float is moving freely before and after every job.
6. Make sure solution tank filters are clean and in place.

Auto-Dump

1. Remove the cap from the male garden hose connection on the rear bottom left of the machine. #10 on page 6.
2. Connect a 3/4" garden hose to the male garden hose connection. #10 on page 6.
3. Secure the opposite end of the garden hose to an approved drain or sewer system. Secure end of hose to prevent flooding.
4. When ready to start recovering water, turn on the PUMPOUT switch. #9 on page 5.
5. The pump can be left on throughout your job so long as small amounts of water are flowing through the pump. Turn off the PUMPOUT switch if you will not be recovering water for periods lasting longer than 2 minutes.
6. Clean your Auto-Dump filter and vacuum filter bag after every job. Some jobs, such as carpet may require multiple cleanings of the filter during operation.

PRIMING THE PUMP:

THE ENDEAVOR HAS A PISTON PUMP WHICH IS NOT SELF-PRIMING. SHOULD AIR BE INTRODUCED INTO THE SYSTEM, PRIMING WILL REMOVE IT AND RESTORE PRESSURE TO THE PUMP SYSTEM.

WARNING: TO PREVENT FLOODING, NEVER WALK AWAY FROM THE MACHINE WHILE THE PRIMING VALVE IS IN THE OPEN POSITION. ALWAYS CLOSE WHEN PRIMING IS FINISHED.

1. Fill the solution tank by using the Auto-Fill feature or by using a bucket or hose to fill from the solution tank access point (see #5 on page 4)
2. Open the pump line by turning the priming valve a 1/4 turn counter-clockwise toward the letter "P". (See #10 on page 7)

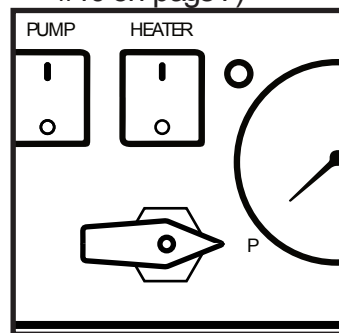

3. Place the pump switch into the on position. Position "I" (see #2 on page 7)
4. Allow the pump to run for 15-20 seconds.
5. Close the priming valve and return it to its original position.

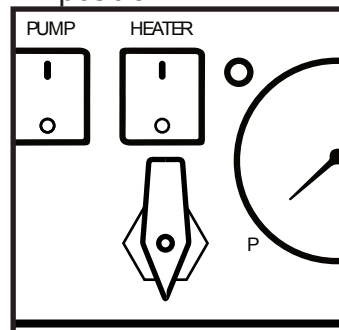

6. Once the priming valve has been closed, the gauge will display the current pressure. Use the regulator to adjust pressure, if necessary. See page 11 to adjust pressure.
7. Repeat steps 1-5 if pressure on gauge is still showing less than desired pressure.

ADJUSTING PUMP PRESSURE:

This machine is equipped with a pressure regulator (see #6 on page 7), that allows the operator to adjust the pressure between 100PSI and 1100PSI. The pressure required for different textiles and surfaces will vary. Verify max pressure for the specific surface you are cleaning to avoid damage. **Do not adjust the pressure while spraying, as the gauge will not display an accurate reading.** Do not exceed 1100PSI. Verify max operating requirements and limits of attachments to avoid damaging your ENDEAVOR or equipment. For example, a carpet wand should not be run above 500PSI, if it does not have the correct spray tips for that pressure. This could cause the pump motor to overheat.

To adjust pressure:

1. Turn Pump switch to on position. Position "I". Do not spray.
2. Check current pressure on pressure gauge. (#5 on page 7)
3. To increase pressure, turn the regulator in a clockwise motion. Watch the gauge and stop rotating the regulator when the desired pressure has been reached. Max pressure is 1100PSI.

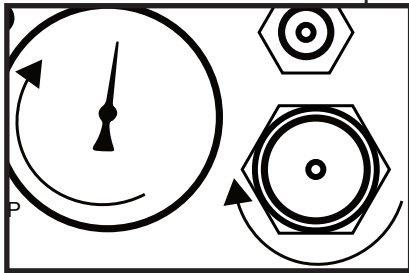

4. To decrease pressure, turn the regulator in a counter-clockwise motion. Watch the gauge and stop rotating the regulator when the desired pressure has been reached. Minimum pressure is 100PSI. Take care when reducing the pressure below 100PSI as the regulator adjuster nut may come off the threaded regulator shaft.

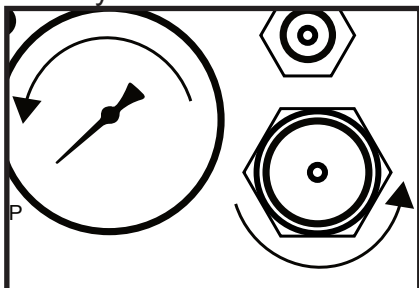

OPERATING THE HEATER FOR CARPET AND UPHOLSTERY CLEANING:

The 9000I-HSH is equipped with a 2000watt heater. The heater will only operate under the following conditions:

- When both power cords are plugged into two separate circuits
- When the pressure on the machine has been reduced to below 500PSI.

To use the heater:

1. Connect Solution line to #7 on page 7. Connect vacuum hose to #8 on page 7.
2. Connect your accessory wand or upholstery attachment.
3. Place water in the solution tank using the Auto-Fill feature or by using a bucket or hose to fill from the solution tank access point (see #5 on page 6)
4. Turn Pump switch to on position. Position "I".
5. Prime if necessary. See priming section on page 9.
6. Spray for 15-30 seconds or until you have a steady stream. This will fill the heater tank with water and prevent air pockets that could cause overheating.
7. Turn on heater switch to position "I". If you are above 500PSI, the heater may not turn on until you reduce the pressure to around 400-450PSI. Slowly reduce the pressure until the heater switch lights up green. If you would like to increase the pressure to 500PSI, you may do so. You may use the heater at pressures of 100-500PSI.
8. Once the heater switch light comes on, wait up to 3 minutes for the heater switch light to turn off.
9. Once the light turns off, the heater is ready to provide hot water for carpet cleaning and upholstery applications.
10. Use wet pass/dry pass spray patterns to allow the heater sufficient time to heat the liquid passing through the tank.
11. The light on the heater switch may stay on throughout the rest of the job.

Note: The heater will not provide maximum heat for accessories that require continuous spray. Because of the current required to power the heater, the heater is disabled while the pump is pressures above 500PSI. Do not shut off the heater by increasing pressure as it may not immediately turn off. Turn heater off using the switch.

HOW TO SETUP THE ENDEAVOR FOR CLEANING CARPET OR UPHOLSTERY:

1. Plug in power cords as per instructions on page 8.
2. Make sure you are on 2 circuits.
3. Connect your solution and vacuum hoses to machine and accessories.
4. Fill the machine with water. See page 10 for auto fill instructions.
5. Prime the pump as per instructions on page 10.
6. Adjust the pressure to between 100-500psi. See instructions and limitations for adjusting pressure on page 11.
7. See heater operating instructions on page 11 if you would like to use heat.
8. Prespray the carpet or fabric as necessary.
9. Turn on the vacuum motor.
10. Spray on the backstroke and do a dry stroke when pushing forward.
11. Overlap your previous path slightly when you pull back.
12. Monitor the levels in the recovery tank and empty as necessary. Use defoamer to ensure your vacuum motor does not take in fluid

HOW TO SETUP THE ENDEAVOR FOR TILE AND GROUT:

1. Plug in power cords as per instructions on page 8.
2. Make sure you are on 2 circuits.
3. Connect your solution and vacuum hoses to machine and accessories.
4. Fill the machine with water. See page 10 for auto fill instructions.
5. Prime the pump as per instructions on page 10.
6. Adjust the pressure to between 500-1100psi. See instructions and limitations for adjusting pressure on page 11.
7. Prespray the tile and grout surface to be cleaned.
8. Turn on the vacuum motor.
9. Spray and extract using the REVOLUTION in a side to side motion.
10. Monitor the levels in the recovery tank and empty as necessary. Use defoamer to ensure your vacuum motor does not take in fluid.

MOUNTING THE OPTIONAL 991RS ACCESSORY CHEMICAL INJECTOR SYSTEM (NOT INCLUDED):

If you have purchased a 991RS Chemical Injector System for your ENDEAVOR. Follow the detailed instructions in the 991RS manual to install onto the ENDEAVOR body.

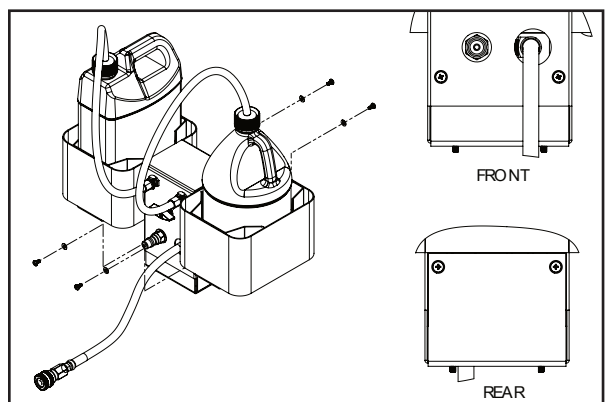
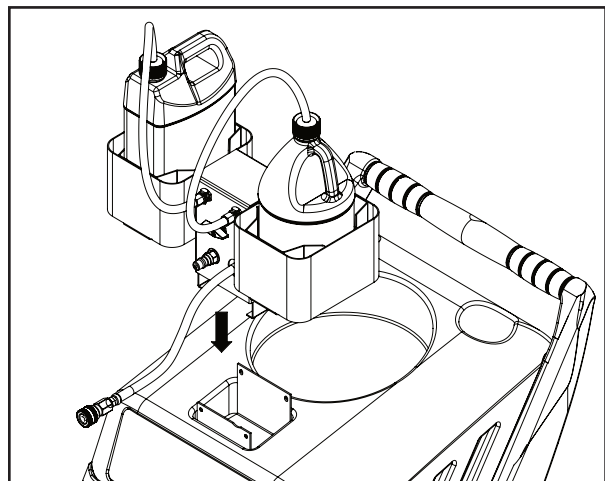
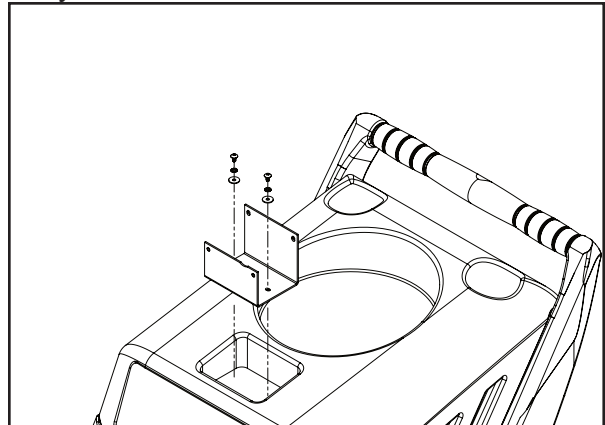

SET UP OF THE OPTIONAL 991RS ACCESSORY CHEMICAL INJECTOR SYSTEM (NOT INCLUDED):

STEP 1.

Locate the short blue hose on the 991RS. Connect it to the male quick connect on the switch panel of the EN-DEAVOR. #7 on page 7.

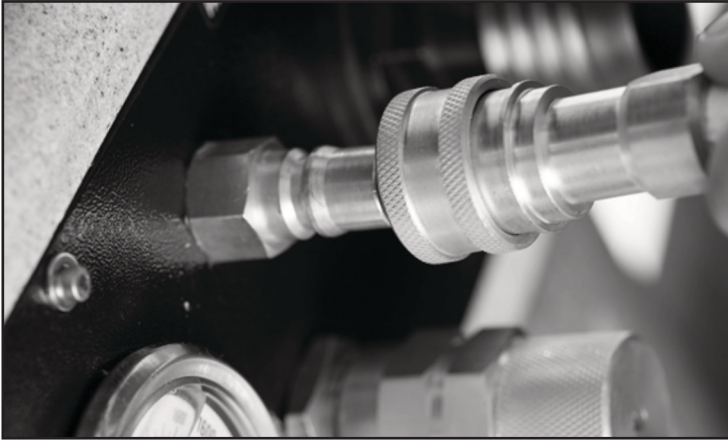

STEP 2.

Connect the female quick connect on your 25FT working solution hose to the male quick connect on the main body of the 991RS.



STEP 3.

The intake bottle caps, and the clear hoses that are attached to them, are designed to be removed and interchanged by way of a quick release system. When you first receive your new 991RS, you will need to install the hoses by pushing them inside the quick release openings. See 991RS manual for detailed instructions.



To remove the hose, push down on the release tab and pull back on the hose.



Extra intake bottle Cap/ hose assemblies are available for purchase.

STEP 4.
Separate the clear hose from the intake bottle cap.



STEP 6.
Once the tip has been installed, push the clear hose back into place over the hose barb.

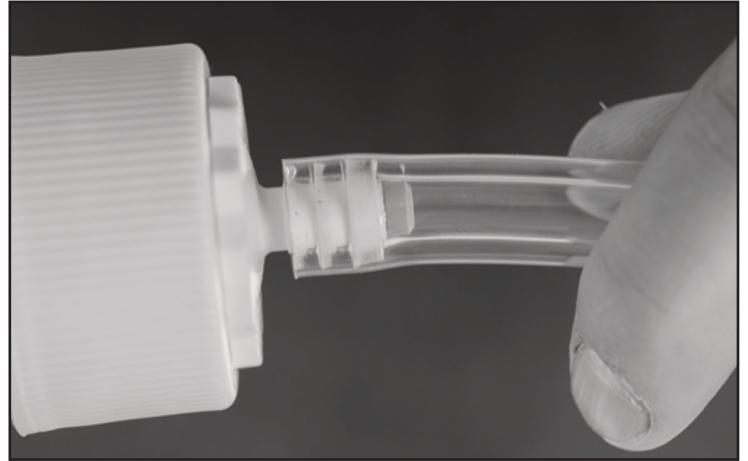

STEP 5.
Locate the brass threaded insert on the intake bottle cap barb and install a metering tip by threading it in a clockwise motion.

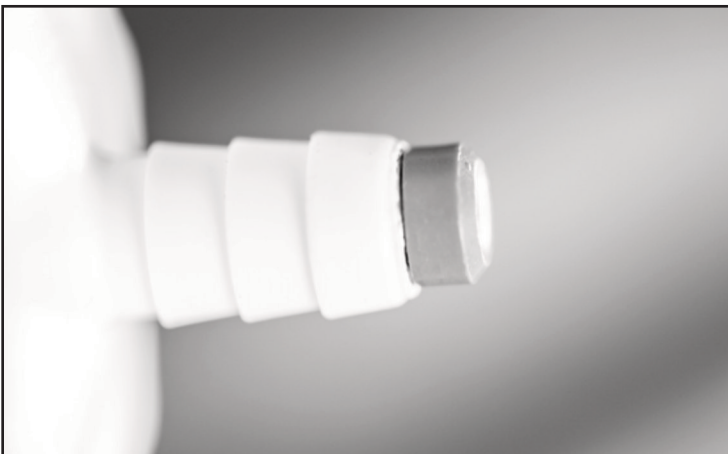

STEP 7.
Place your chemical bottles in the bottle holders and install the threaded intake caps.



SELECTING CHEMICAL ON OPTIONAL 991RS (NOT INCLUDED):

Use the chemical selector valve to change between the left side and right side bottle holders. For accurate flow rates, point the selector valve straight at the bottle holder you wish to draw from. Place the selector valve at top dead center to close the injector system. The system will not draw chemical in the closed position.

LEFT BOTTLE

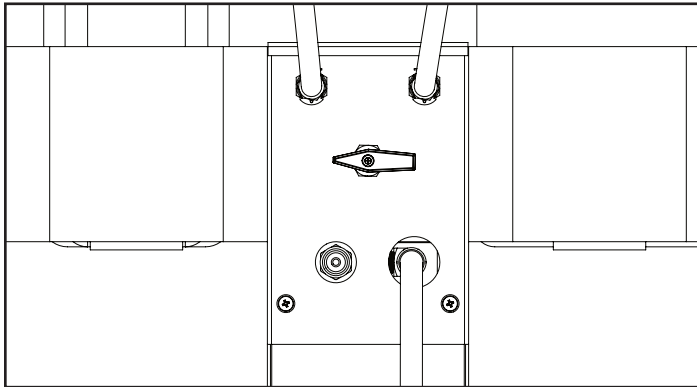

RIGHT BOTTLE

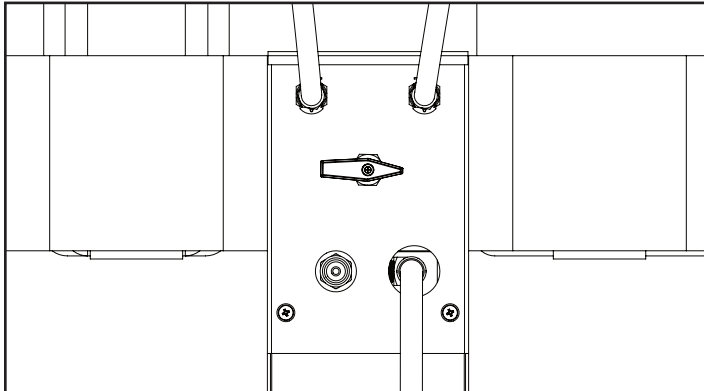

CLOSED

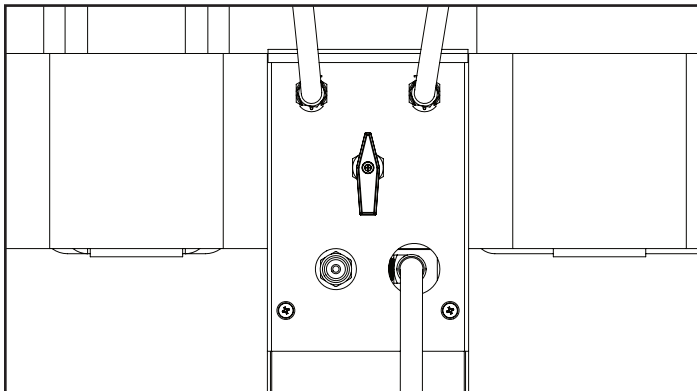

USING OPTIONAL 9000AC SPRAYER (NOT INCLUDED):

Use the spray collar to select between low pressure chemical application or high pressure rinse. Pop "OUT" for low pressure and "IN" for high pressure.

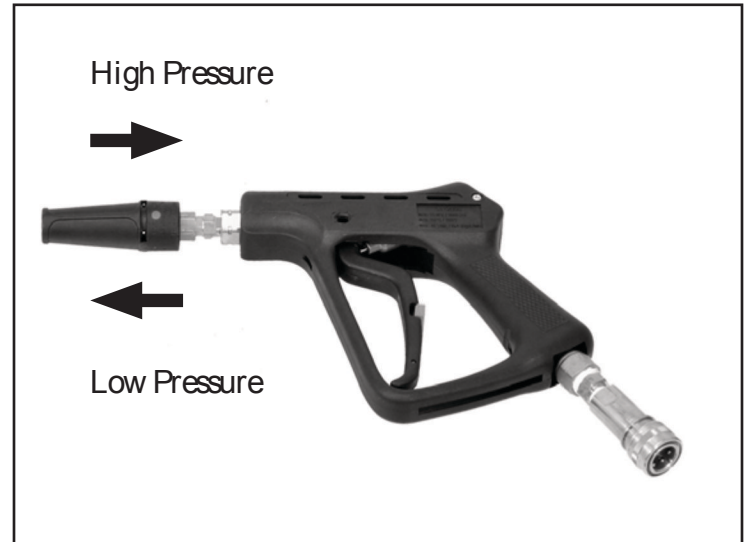

You may also adjust the angle of spray from a concentrated stream to a wider pattern by rotating the spray collar clockwise or counter-clockwise.

Note: Chemical cannot be applied in the high pressure rinse mode.

TOUCH-LESS HARD SURFACE CLEANING USING THE 991RS CHEMICAL INJECTOR SYSTEM ON THE ENDEAVOR:

Use the following instructions as a basic guideline to clean hard surfaces using the ENDEAVOR and the 991RS system.

1. Select the appropriate tip and install on the intake cap.
2. Place bottles into the bottle holders.
3. Select chemical using chemical selector valve.
4. Take the feed tube attached to the intake cap and place it inside the bottle. Thread the intake cap onto the bottle.
1. Plug in power cords as per instructions on page 6.
2. Make sure you are on 2 circuits.
3. Connect your solution hose to machine and 9000AC

- spray gun.
4. Fill the machine with water. See page 10 for auto fill instructions.
 5. Prime the pump as per instructions on page 9.
 6. Adjust the pressure to 500psi. See instructions on page 9.
 7. Chemical will draw only in the “LOW” pressure setting of your pressure gun. To activate the “LOW” pressure setting, pop the collar of the gun out.
 8. In “LOW” pressure, apply chemical to the walls and fixtures starting from the lowest point to the highest.
 9. Spray the floor as you make your way out of the room.
 10. Allow the chemical time to dwell according to the chemical manufacturers recommendations.
 11. You may use a brush to agitate particularly soiled areas.
 12. When you are ready to rinse away the chemical, pull the collar of your 9000AC “IN”, to activate high pressure rinse mode. If you require a higher volume of flow for rinse mode, you may bypass the 991RS chemical injector system by connecting your 25ft hose directly to the male quick connect on the EN-DEAVOR's control panel.
 13. Rinse surfaces starting from the top and working your way down.
 14. Use a 334ACH squeegee wand to extract the excess fluid from the floor.

90001-HSH
ENDEAVOR SOLUTION TANK
EXPLODED VIEW
5/5/2017

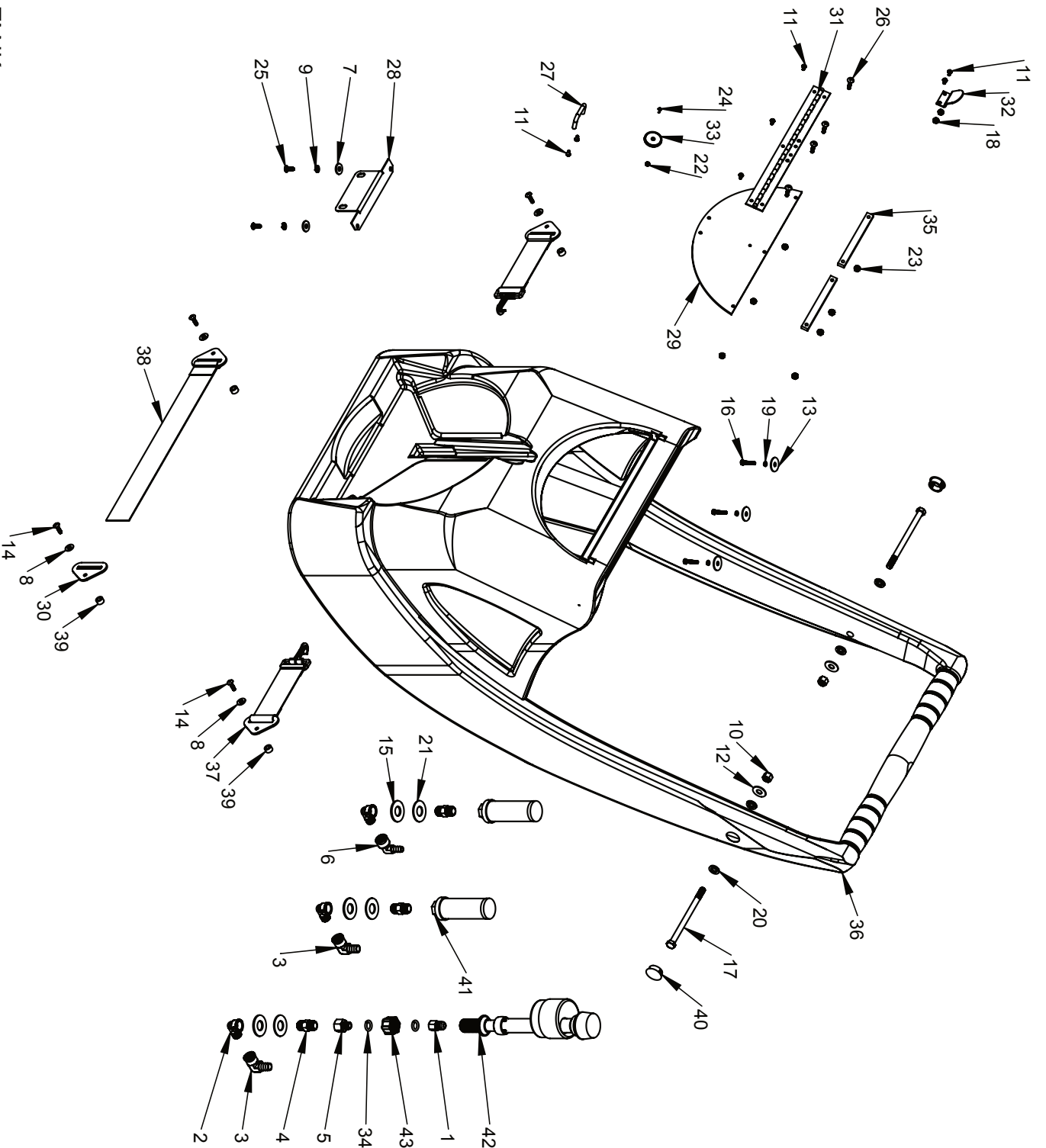



9000I-HSH
 ENDEAVOR SOLUTION TANK
 EXPLODED VIEW
 5/5/2017

ITEM NO.	PART NUMBER	DESCRIPTION	QTY.
1	A00118	BUSHING, 1/4 FP X 3/8 SAE	1
2	A11949	3/8 MF 90 DEGREE ELBOW	3
3	A13271	3/8 FP X 1/2 BARB, ELBOW	2
4	A13445	3/8 MIP HEX NIPPLE	3
5	A13606	3/8 X 1/4 FIP X MIP, ADP	1
6	A13849	ELBOW, 90 DEGREE, 3/8H x 3/8F	1
7	C00233	WASHER, FLAT, USS, 1/4	2
8	C00233-1	WASHER, FLAT, 1/4 SS	4
9	C00254	LOCKWASHER, 1/4 SPLIT	2
10	C00279	LOCKNUT, 3/8 NYLON, ZINC	2
11	C00311	SCREW, 8-32 x .375	7
12	C10503	WASHER, FLAT 1 x .048	2
13	C12039	FENDER WASHER, 1/4" ID, 1" OD	3
14	C13351	SCREW, 10-32 x 3/4, TRUSS, SS	4
15	C13421	WASHER, .687 ID, 1.5 OD	3
16	C13535	SCREW, 10-32 X 1, HEX	3
17	C13559	HEX BOLT, 5/16 X 5 1/2, SS	2
18	C13666	NUT, KEP, 8-32 SS	5
19	C13740	LOCKWASHER, #10, SPLIT	3
20	C13859	WASHER, NEOPRENE BONDED	4
21	C13871	WASHER, 11/16, SS	3
22	C13939	NUT, KEP, #4-40, SS	1
23	C13940	NUT, KEP, 10-32, SS	4
24	C13948	SCREW, #4-40 X 3/8 PH	1
25	C90007	SCREW, 10-32 x 5/8, TRUSS HEAD	2
26	C90007-1	10-32 X 1, TRUSS, SS	4
27	D13315	HANDLE, LID	1
28	D13347	LATCH NOSE, TOP	1
29	D13355	LID, SOLUTION TANK	1
30	D13362	D-PLATE, STRAP	1
31	D13479	HINGE	1
32	D13912	CATCH, LID MAGNET	1
33	D13926	MAGNET, CUP	1
34	E13653	O-RING, SILICONE	2
35	E13924	GASKET, LID HINGE	2
36	F13295	SOLUTION TANK, BLUE GRANITE	1
37	F13548	STRAP, VELCRO, SHORT	2
38	F13549	STRAP, VELCRO, LONG	1
39	K00727	SPACER, .5 OD X .257 ID X .3 H	4
40	K10510	PLUG, 1" ROUND, SNAP-IN	2
41	K13398	FILTER, SUCTION, 80 MESH	2
42	K13510	FILL VALVE, ANTI-SIPHON	1
43	K13966	SUPPLY NUT	1

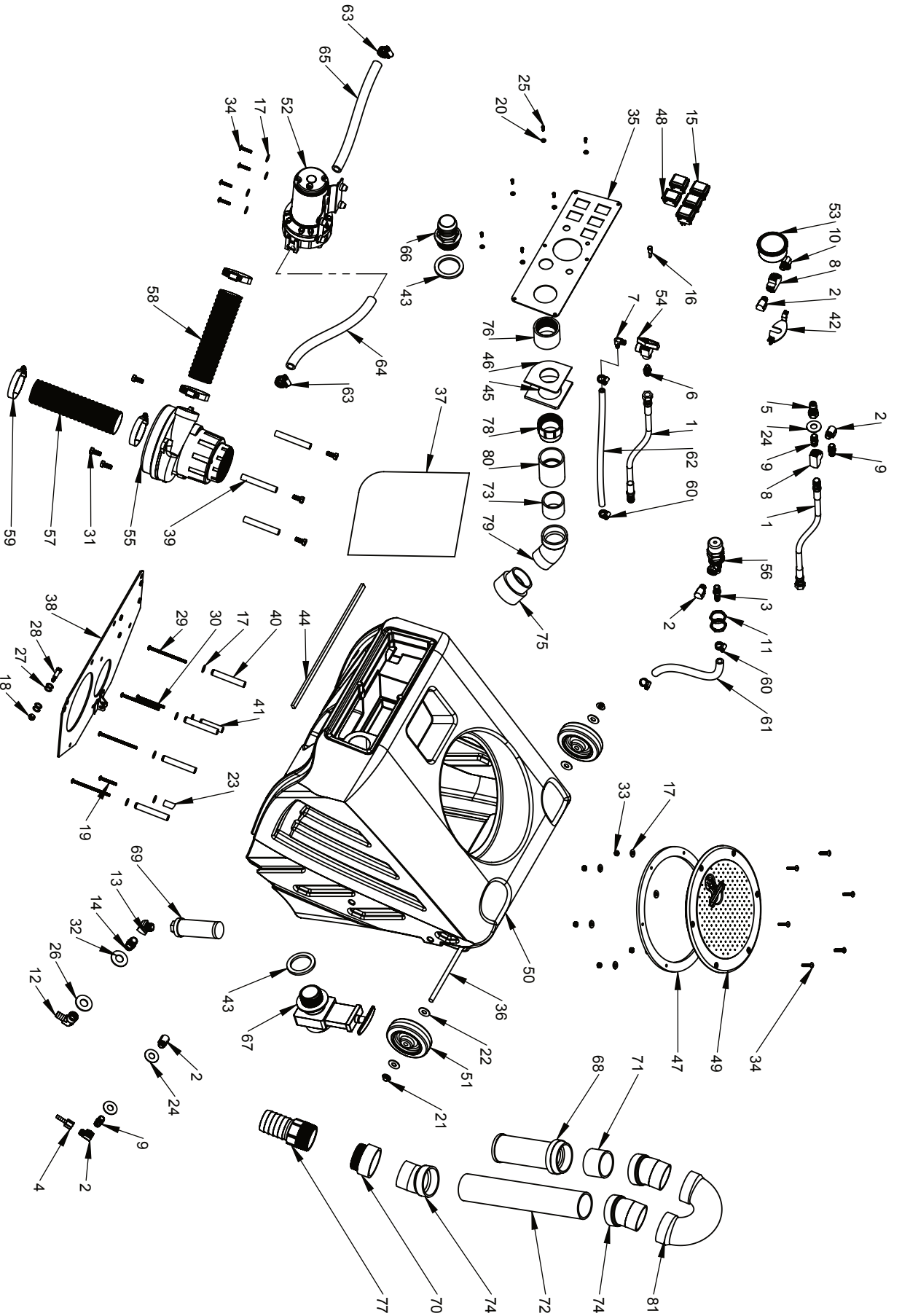



9000I-HSH
 ENDEAVOR RECOVERY TANK
 EXPLODED VIEW
 5/5/2017

ITEM NO.	PART NUMBER	DESCRIPTION	QTY.
1	--	SOLUTION HOSE, HIGH PRESSURE, 10"	2
	J00580	SOL. HOSE, 10"	1
	J00659	SWAGE FITTING, 1/4MP	1
	J00660	SWAGE FITTING, 1/4FP	1
2	A00052	90 DEGREE ELBOW, .25" MP X .25" FP	5
3	A00060	BARB, .375" X .25" MPT, BRASS	1
4	A00067	1/4 BARB X 1/4 FP, BRASS	1
5	A00104	QD 1/4M x 1/4FP BRASS	1
6	A00114B	HEX NIPPLE, .25" MP X .125" MP	1
7	A00134	90 DEGREE ELBOW, .25" BARB X .125" MPT	1
8	A00161	TEE, .25" FP X .25" FP X .25" FP	2
9	A12960	1/4 HEX NIPPLE, BRASS	3
10	A13005	90 ELBOW, 1/4MP x 1/4MP	1
11	A13082	LOCKNUT, 1" BRASS	2
12	A13271	3/8 FP X 1/2 BARB, ELBOW	1
13	A13378	ELBOW, 45 DEGREE, 3/8MIP X 3/8 FIP	1
14	A13445	3/8 MIP HEX NIPPLE	1
15	B02211-1	SWITCH, ROCKER GREEN LIT	4
16	B11756	INDICATOR LIGHT	1
17	C00233-1	WASHER, FLAT, 1/4 SS	16
18	C00273	1/4-20 NYLON-INSERT LOCKNUT	1
19	C00328-112	SCREW, 10-32 X 1 1/2 PH	1
20	C02231	#8 WASHER, SAE, SS	6
21	C02305-1	CAP NUT, .375", PUSH-ON	2
22	C10503	WASHER, FLAT 1 x .048	4
23	C11440	SPACER, 1/4-20 X 1"	1
24	C13024	WASHER, .5 ID SS	3
25	C13353	SCREW, 6-32 x 3/8, SC HS, SS	6
26	C13421	WASHER, .687 ID, 1.5 OD	1
27	C13623	FLATWASHER, .416 ID X .632 OD	4
28	C13814	SCREW, SHOULDER, 5/16D x 3/4L x 1/4-20	1
29	C13822	SCREW, 10-32 X 3 1/2 PH SS	4
30	C13823	SCREW, 10-32 X 2 1/2 PH SS	1
31	C13844	SCREW, HEX HEAD SS	6
32	C13871	WASHER, 11/16, SS	1
33	C14105	LOCKNUT, 10-32, NYLON, BRASS	6
34	C90007-1	10-32 X 1, TRUSS, SS	10
35	D13339	CONTROL PANEL	1
36	D13350	SHAFT, LAY DOWN	1
37	D13361	BAG, INTAKE FILTER	1
38	D13797	PLATE, VACUUM MOTOR 8.4	1
39	D13855	SPACER, ALUMINUM	3
40	D13856	SPACER, ALUMINUM 3"	4



9000I-HSH
ENDEAVOR RECOVERY TANK
EXPLODED VIEW
5/5/2017

ITEM NO.	PART NUMBER	DESCRIPTION	QTY.
41	D13857	SPACER, ALUMINUM 2"	1
42	D14140	U-CLAMP	1
43	E11128	GASKET, DRAIN VALVE	2
44	E13338	GASKET	1
45	E13686-A	GASKET, AIR INTAKE	1
46	E13686-B	GASKET, AIR INTAKE	1
47	E13830	GASKET, RECOVERY LID	1
48	F12118	HOLE COVER, SWITCH	1
49	F13242	DECK PLATE	1
50	F13294	RECOVERY TANK, GREY GRANITE	1
51	G02531-1	WHEEL, 4 INCH	2
52	G13247	PUMP, WASTE WATER	1
53	G13335	GAUGE, 2000PSI	1
54	G13380	VALVE, PRESSURE RELIEF	1
55	G13796	VACUUM MOTOR, 2 STAGE, 8.4	1
56	G14041	REGULATOR, 1200 PSI	1
57	J00618	HOSE, 2"ID GREY, 20" L	1
58	J00621	VAC HOSE, 2"ID BLACK, 23" L	1
59	J00639	CLAMP, HOSE 2.0	4
60	J00651	HOSE CLAMP, .25" TO .625"	4
61	J11154	SOL. HOSE, 100 PSI WIRE, .375" ID X 42" L	1
62	J11154-1	SOL. HOSE .25" ID X 30" L	1
63	J11508	SCREW CLAMP, #6	2
64	J11933	1/2" POLYWIRE PVC HOSE, 22"	1
65	J11933	1/2" POLYWIRE PVC HOSE, 34"	1
66	K00665-1	HOSE ADAPTER, 1.5 INCH	1
67	K00711	DRAIN VALVE, BLACK	1
68	K13364	FLOAT, SHUT-OFF	1
69	K13397	FILTER, SUC TION, 60 MESH	1
70	K13400	ADAPTER, 2" HUB x MIPT	1
71	K13405	PIPE, 2" SCH40 ABS, 1.625"L	1
72	K13405	PIPE, 2" SCH40, ABS, 12.375"L	1
73	K13406	PIPE, 1.5" ABS, 1.5"L	1
74	K13476	ELBOW, 2 IN. 22-1/2 DEG	3
75	K13477	REDUCER, 2" x 1 1/2"ABS	1
76	K13741	ADAPTER, FEMALE 1 1/2"	1
77	K13805	INSERT, BARB, 2H, 2MPT	1
78	K13843	ADAPTER, 1.5" PVC, SCH40	1
79	K13864	ELBOW, 45 DEGREE	1
80	K13872	COUPLING, 1-1/2, NO THREAD	1
81	K13873	RETURN BEND, ABS 2"	1

90001-HSH
ENDEAVOR BASE
EXPLODED VIEW
5/5/2017

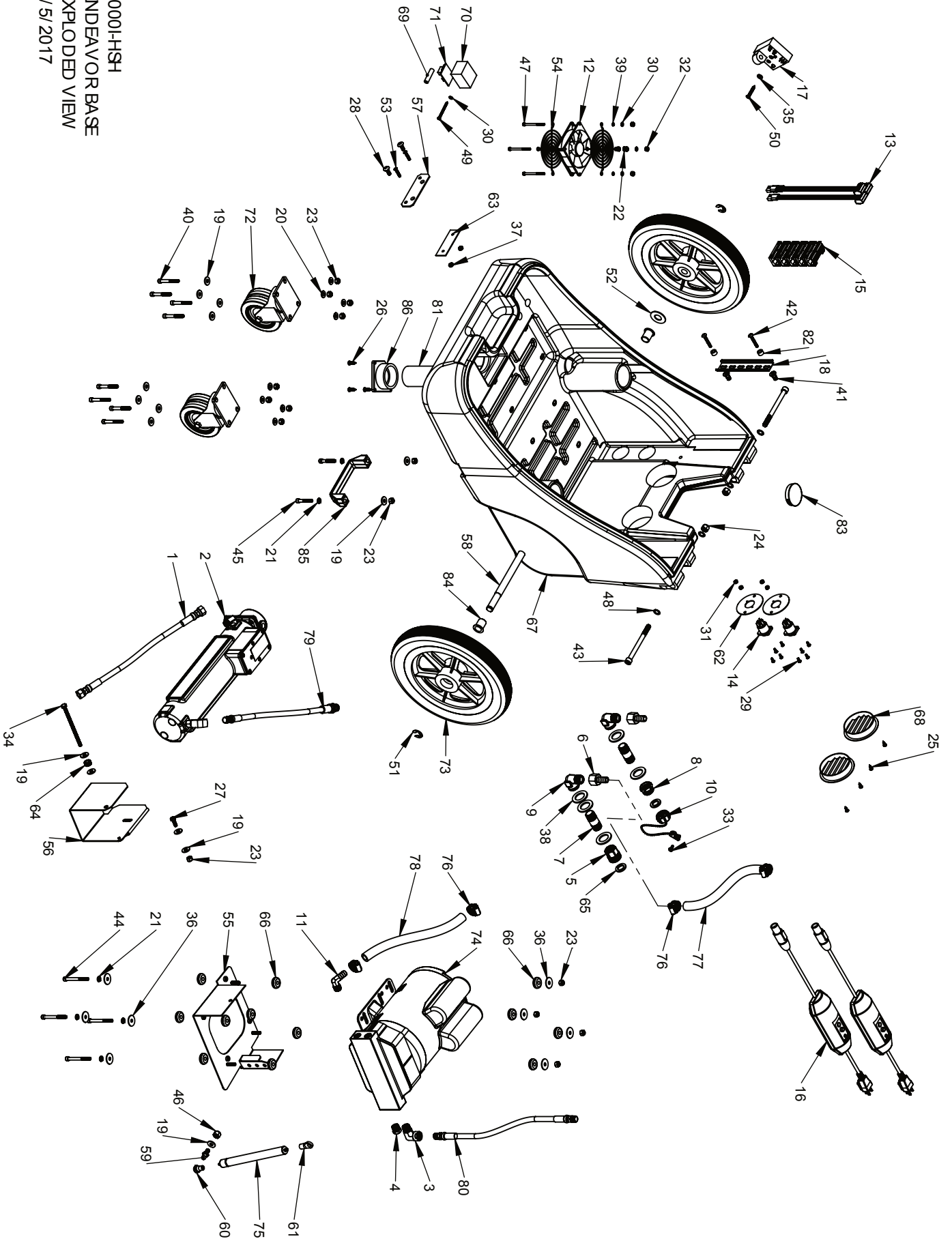



9000I-HSH
 ENDEAVOR BASE
 EXPLODED VIEW
 5/5/2017

ITEM NO.	PART NUMBER	DESCRIPTION	QTY.
1	--	SOL. HOSE, HIGH PRESSURE	1
	J00580	SOL. HOSE, 6'	1
	J00660	SWAGE FITTING, 1/4FP	2
2	720HR	HEATER	1
3	A12917	ELBOW, .25" F X .375" M, NPT	1
4	A13078	PLUG, MALE, 3/8"	1
5	A13257	SWIVEL, 3/4 FGH X 1/2 FP	1
6	A13258	1/2 HOSE BARB X 1/2 FP	2
7	A13260	1/2 X 2 NIPPLE, BRASS	2
8	A13261	MALE HOSE X 1/2 FIP	1
9	A13262	1/2 STREET ELBOW	2
10	A13424	CAP W/ CHAIN	1
11	A13430	BARB, ELBOW, .375" MP X .5" BARB	1
12	B13280	COOLING FAN	1
13	B13395	WIRE HARNESS	1
14	B13734	CONNECTOR, 3-PIN, MALE	2
15	B13738	MOUNTING CARRIER, LEVER	5
16	B13795	POWERCORD, GFCI 12GA 25FT	2
17	B13816	CURRENT SENSOR	1
18	B13851	DIN RAIL	1
19	C00233	WASHER, FLAT, USS, 1/4	15
20	C00233-1	WASHER, FLAT, 1/4 SS	8
21	C00254	LOCKWASHER, 1/4 SPLIT	6
22	C00256	LOCKWASHER, #10 EXT. STAR	2
23	C00273	1/4-20 NYLON-INSERT LOCKNUT	15
24	C00279	LOCKNUT, 3/8 NYLON, ZINC	2
25	C00293	#8 X 1/2 PH SMS	4
26	C00295-1	#10 X 3/4 PH SMS	3
27	C00313	HEX BOLT, 1/4-20 X 3/4	1
28	C00316	SCREW, 1/4-20 X 3/4, PH, SS	2
29	C00324-38	SCREW, 6-32 X 3/8, RH	8
30	C02231	#8 WASHER, SAE, SS	5
31	C02274	LOCKNUT, NYLON, #6-32	4
32	C02320	LOCKNUT, 8-32, NYLON, SS	4
33	C10737	SCREW, 8-32 x 0.625 SS TRUSS	1
34	C11189	HEX BOLT, 1/4-20 X 4.5"	1
35	C11955	WASHER, FLAT, #10	1
36	C12039	FENDER WASHER, 1/4" ID, 1" OD	8
37	C13025	HEX NUT, 10-32 WITH EXT. LOCK WASHER	2
38	C13242	WASHER, 7/8 X 1 1/2, SS	5
39	C13308	#8 SPLITLOCK WASHER	4
40	C13356	SCREW, 1/4-20 X 2 SHCS	8
41	C13388	JACK NUT, 10-24, ZINC PLATED	2



9000I-HSH
ENDEAVOR BASE
EXPLODED VIEW
5/5/2017

ITEM NO.	PART NUMBER	DESCRIPTION	QTY.
42	C 13389	SCREW, 10-24 X 1 1/2, TRUSS	2
43	C 13391	SCHS 3/8-16 x 4 1/2 SS	2
44	C 13431	1/4-20 X 2 1/2 SHCS, ZINC PLATED	4
45	C 13432	1/4-20 X 1 1/2 SHCS, ZINC PLATED	2
46	C 13433	LOCKNUT, 5/16-18, NYLON	1
47	C 13434	8-32 X 2 1/4 SHCS, SS	4
48	C 13623	FLAT WASHER, .416 ID X .632 OD	4
49	C 13834	SCREW, #6 X 2 SMS, SS	1
50	C 13847	SCREW, #12 X 1 1/2 FH SMS SS	1
51	C 13861	E-RING, 5/8	2
52	C 13871	WASHER, 11/16, SS	1
53	C 14093	SCREW, 10-32 X 1, FHS SS	2
54	D13281	FAN GUARD, 92MM	2
55	D13340	BRACKET, PUMP	1
56	D13343	BRACKET, HEATER	1
57	D13348	LATCH, NOSE, BOTTOM	1
58	D13356	SHAFT, MAIN AXLE	1
59	D13435	BALL MOUNT, GAS SPRING	1
60	D13436	BALL SOCKET, 10MM	1
61	D13437	EYELET, GAS SPRING	1
62	D13729	CAP, POWER, ENTRY	2
63	D14057	PLATE, WASHER	1
64	E00449	GROMMET	1
65	E13246	WASHER, WATER HOSE	2
66	E13440	GROMMET, .278ID	12
67	F13296	BASE, BLUE GRANITE	1
68	F13820	LOUVER, 3", BLACK	2
69	F13832	SPACER, .375 OD, .192 ID	1
70	F13833	BOX POTTING	1
71	G 11609	SENSOR, CIRCUIT	1
72	G 13218	CASTER, 4" TWIN WHEEL	2
73	G 13248	WHEEL, 12 INCH	2
74	G 13333	PUMP, 1100 PSI	1
75	G 13801	GAS SPRING, 120 LB RATED	1
76	J11508	SCREW CLAMP, #6	4
77	J11933	1/2" POLYWIRE PVC, HOSE, 43"	1
78	J11933	1/2" POLYWIRE PVC HOSE, 55"	1
79	J13385A	PULSE HOSE ASSEMBLY, 24 INCH	1
80	J14110A	PULSE HOSE ASSEMBLY, 50 INCH	1
81	K00672	PIPE, 1 1/2 SCH40, PVC, 9"	1
82	K00727	SPACER, .5 OD X .257 ID X .3 H	2
83	K010142	PLUG, 2" BLACK	1
84	K13403	BUSHING, J-FLANGE, .625 ID	2
85	K13602	HANDLE, PULL BACK	1
86	K13828	FLANGE, 1 1/2 PIPE FITTING	1