



TURNER

2007 AUTHORIZED U.S. RIDER HANDBOOK V 1.0

EFFECTIVE SEPT 1, 2006

41615 DATE ST. #105
MURRIETA, CA 92562
(951) 677-1711 • FAX (951) 677-1373
WWW.TURNERBIKES.COM

INTRODUCTION

Turner Bicycles founder David Turner has been at the forefront of MTB suspension since the technology's inception in the 1980's. As a professional racer, David helped designers at Rock Shox, Mongoose and AMP Research race-test and fine-tune early advancements in suspension design. After retiring from full-time competition, David worked with legendary design guru Horst Leitner to create some of the most progressive and lightweight suspension bicycle frames and forks the sport had ever seen.

In 1994, David Turner entered the bicycle market with high-performance frames bearing his own name. Turner suspension frames quickly earned a winning reputation by delivering levels of performance, pedaling efficiency and reliability few riders had ever experienced. The superiority of Turner frames has not been lost on top pros in the sport. Numerous NORBA, World Cup and UCI Championships have been won on Turner frames, and all by riders being paid by other bike companies to endorse their products.

Two thousand seven marks our company's 14th year building high-performance suspension frames for hard-core riders. Next year's Turner line is the most comprehensive in our company's history, and includes long-travel DH race machines, big-hit freeride frames, mid- and short-travel XC frames and even an all-new suspension frame for the 29-inch scene. Other sections of this handbook explain our marketing endeavors for 2007 and give the prices, terms and conditions for becoming an Authorized Turner Dealer.

To grow our business next year, it is our personal goal to form lasting partnerships with dealers that care as much about quality, performance and customer service as we do. If the idea of being an authorized Turner Dealer appeals to you, please contact us personally at your earliest convenience.

NITROUS

Purpose: Hard-core expert- and pro-class cross country

Overview: While his peers struggle to compete against him on knobby-tired road bikes and slick-tired rigid MTB's, Maxxis Team Pro Geoff Kabush has continued for three years to rack up short track and NORBA XC National Championships aboard a full-suspension Turner Nitrous. In 2006 alone, Geoff set the record for all-time short track wins aboard his Turner Nitrous, making our capable cross-country race machine the benchmark of the class.

Features/Benefits:

- 4.5 pounds
- 3" travel
- Fox RP23 shock
- Race specific frame and suspension geometry

Color: Polished Clear Anodized



	Seat tube length	Top Tube length	Head tube length	Wheelbase	Rec'd Height	Standover height	Travel	Head angle	Seat Angle	Chainstay	BB height	Axle to crown
Small	15"	22.5"	3.5"	41.6"	<5'6"	28.3"	3"	71°	73.5°	16.65"	12.25"	450mm
Medium	17"	23.5"	4"	42.6"	5'7"-5'10"	30"	3"	71°	73.5°	16.65"	12.25"	450mm
Large	19"	24.5"	5"	43.6"	5'11"-6'1"	31.5"	3"	71°	73.5°	16.65"	12.25"	450mm

FLUX

Purpose: Mega-mile XC riding/racing on more rugged courses and terrain

Overview: If the Nitrous is the no-holds-barred XC race machine in our line, the 2007 Turner Flux is the pure XC machine for riders who prize strength and stiffness over low mass. The Flux derives its reliability and strength from the custom-formed tubes used in its construction, and from an arsenal of perfectly formed components like dropouts, rocker arms and our signature BB/pivot assembly.

Features/Benefits:

- 5.5 pounds
- 4" travel
- Ultimate endurance racer
- Women-specific 13" frame size available
- Fox RP23 shock

Color: Polished Copper Anodized, Polished Blue Anodized



	Seat tube length	Top Tube length	Head tube length	Wheelbase	Rec'd Height	Standover height	Travel	Head angle	Seat Angle	Chainstay	BB height	Axle to crown
XS	13"	21.2"	3.75"	41.1"	4'11"-5'2"	28.5"	4"	70°	73.5°	16.75"	12.8"	472mm
Small	15"	22.5"	4"	42.3"	5'3"-5'6"	30"	4"	70°	73.5°	16.75"	12.8"	472mm
Medium	17"	23.5"	4"	43.2"	5'7"-5'10"	31"	4"	70°	73.5°	16.75"	12.8"	472mm
Large	19"	24.5"	5"	44.1"	5'11"-6'1"	32"	4"	70°	73.5°	16.75"	12.8"	472mm
XL	22"	25.1"	6"	45"	6'2"-6'4"	33"	4"	70°	73.5°	16.75"	12.8"	472mm

SULTAN

Purpose: Full-suspension XC frame for riders who love the speed, plushness and flow provided by 29-inch wheels

Overview: Two big 29-inch wheels spinning down the trail. For some guys it's the ultimate feeling in off-road riding. We took a conservative approach in designing the 2007 Turner Sultan 29'er. The result is an awesome trail bike that exploits the larger wheel's advantages (faster speed, bigger tire contact patch and greater gyroscopic stability) without compromising the performance characteristics that every Turner frame is famous for. The Sultan's geometry is designed to work with—not against—29-inch wheels to achieve neutral handling, and can be easily set up with a variety of 3- to 5-inch travel forks. The Sultan features a big-wheel variant of our famed Turner rocker suspension to deliver the same plushness and pedaling efficiency as our 26-inch suspension frames.

Features/Benefits:

- 6.0 pounds
- 4" travel
- Famous Turner tires clearance to handle any 29-inch tires available
- Available in Sasquatch sizing (XXL/23") for tall riders
- Fox RP23 shock

Color: Polished Brass Anodized, Blue Anodized



	Seat tube length	Top Tube length	Head tube length	Wheelbase	Rec'd Height	Standover height	Travel	Head angle	Seat Angle	Chainstay	BB height	Axle to crown
Medium	17"	23.5"	3.5"	43.8"	5'7"-5'10"	31.5"	4"	71°	73°	18.2"	13.6"	508mm
Large	19"	24.5"	4.5"	44.7"	5'11"-6'1"	32.5"	4"	71°	73°	18.2"	13.6"	508mm
X Large	21"	25.5"	5.5"	45.6"	6'2"-6'4"	33.5"	4"	71°	73°	18.2"	13.6"	508mm
XX Large	23"	26.5"	6.5"	47.3"	6'5 +	34.5"	4"	71°	73°	18.2"	13.6"	508mm

5 1/2 SPOT

Purpose: Simply the most versatile trail bike in the Turner arsenal. The 2007 5 1/2 Spot can be equipped to do almost anything: marathon XC competition, trail riding and 4X racing

Overview: Opinions regarding what the optimum wheel travel on a heavy-duty trail/XC frame should be have forced a name change on our most popular frame for 2007. As the quality of components, the strength of lightweight alloys and the skills of riders have increased, so too has the demand for greater wheel travel on today's off-road machines. The 2007 5 1/2 Spot received subtle but significant changes to accommodate today's more aggressive and versatile riders. These changes weren't done to make the 5 1/2 Spot a different machine, but simply to keep it at the top of its class.

Features/Benefits:

- Redesigned rocker for increased travel
- 6.2 pounds
- 5.5" travel
- No increase in frame weight
- Torsionally stiffer longer travel rocker assembly
- Fox RP23 shock
- Redesigned chainstay for increased lateral and torsional stiffness
- Excellent mud and tire clearance

Color: Black Anodized, Matte Deep Red Anodized



	Seat tube length	Top Tube length	Head tube length	Wheelbase	Rec'd Height	Standover height	Travel	Head angle	Seat Angle	Chainstay	BB height	Axle to crown
Small	15"	22.2"	4"	43"	5'3"-5'6"	30"	5.5"	69°	73°	16.9"	13.4"	515mm
Medium	17"	23"	4"	43.8"	5'7"-5'10"	31"	5.5"	69°	73°	16.9"	13.4"	515mm
Large	19"	23.9"	5"	44.7"	5'11"-6'1"	32"	5.5"	69°	73°	16.9"	13.4"	515mm
XL	22"	24.8"	6"	45.6"	6'2"-6'4"	33"	5.5"	69°	73°	16.9"	13.4"	515mm
XXL	24"	26.5"	7"	47.3"	6'5 +	34"	5.5"	69°	73°	16.9"	13.4"	515mm

RFX

Purpose: Rough XC and all-mountain riding

Overview: The Turner RFX has been completely redesigned for 2007. The challenge was to maintain the RFX's dominance among super-strong great-pedaling über XC/all-mountain machines while shaving its weight by 1.5 pounds. We accomplished this feat by engineering a completely new rocker arm and rear triangle that works in perfect harmony with Fox's DHX Air shock. The result is a Turner frame that delivers 6.4 inches of rear wheel travel. Despite its amazing combination of long travel and lightness, the 2007 Turner RFX is no disposable trail bike. Thanks to its custom-shaped tubing and super-strong machined head tube, the 2007 RFX is built to deliver unparalleled pedaling efficiency, trail dominance and handling for years and years.

Features/Benefits:

- 7.2 pounds
- 6.4" travel
- Completely re-designed suspension with lowered ratio
- Fox DHX Air 5.0
- Revised geometry for perfect all mountain handling

Color: Polished Emerald Green Anodized, Polished Bronze Anodized



	Seat tube length	Top Tube length	Head tube length	Wheelbase	Rec'd Height	Standover height	Travel	Head angle	Seat Angle	Chainstay	BB height	Axle to crown
Small	15"	22"	4.25"	43.2"	5'3"-5'6"	30.2"	6.3"	68°	72.5°	17"	14.1"	535mm
Medium	17"	22.9"	4.5"	44.1"	5'7"-5'10"	31"	6.3"	68°	72.5°	17"	14.1"	535mm
Large	19"	23.8"	5.25"	45"	5'11"-6'1"	32"	6.3"	68°	72.5°	17"	14.1"	535mm
XL	21"	24.6"	6.25"	45.8"	6'2"-6'4"	33"	6.3"	68°	72.5°	17"	14.1"	535mm
XXL	23"	26.3"	7"	47.5"	6'5 +	34"	6.3"	68°	72.5°	17"	14.1"	535mm

HIGHLINE

Purpose: Aggressive descending on the roughest technical terrain

Overview: The 2007 Highline is rolling proof that Dave Turner not only knows how to design great bikes, he knows how to listen to great riders. In its first year on the market, the 2006 Highline garnered immediate praise for its amazing big-hit and aggressive freeride capabilities. By equipping the 2007 Turner Highline with a shorter 2.5-inch travel shock, we have reduced its wheel travel to 7.1 inches. This modification provides greater versatility, especially when the bike is equipped with a single-crown XL travel fork (1.5" head tube.) Thanks to the Highline's proper suspension design, our hard-core freeride machine can also climb with amazing efficiency.

Features/Benefits:

- 10.5 pounds with coil spring shock
- 7.1" travel
- Fox DHX 5.0 coil spring shock
- Full-length seat tube for greater versatility and lateral stiffness
- Full complement sealed roller bearings at all pivot points
- Grease fittings for easy maintenance

Color: Polished Clear Anodized, Matte Blue Anodized

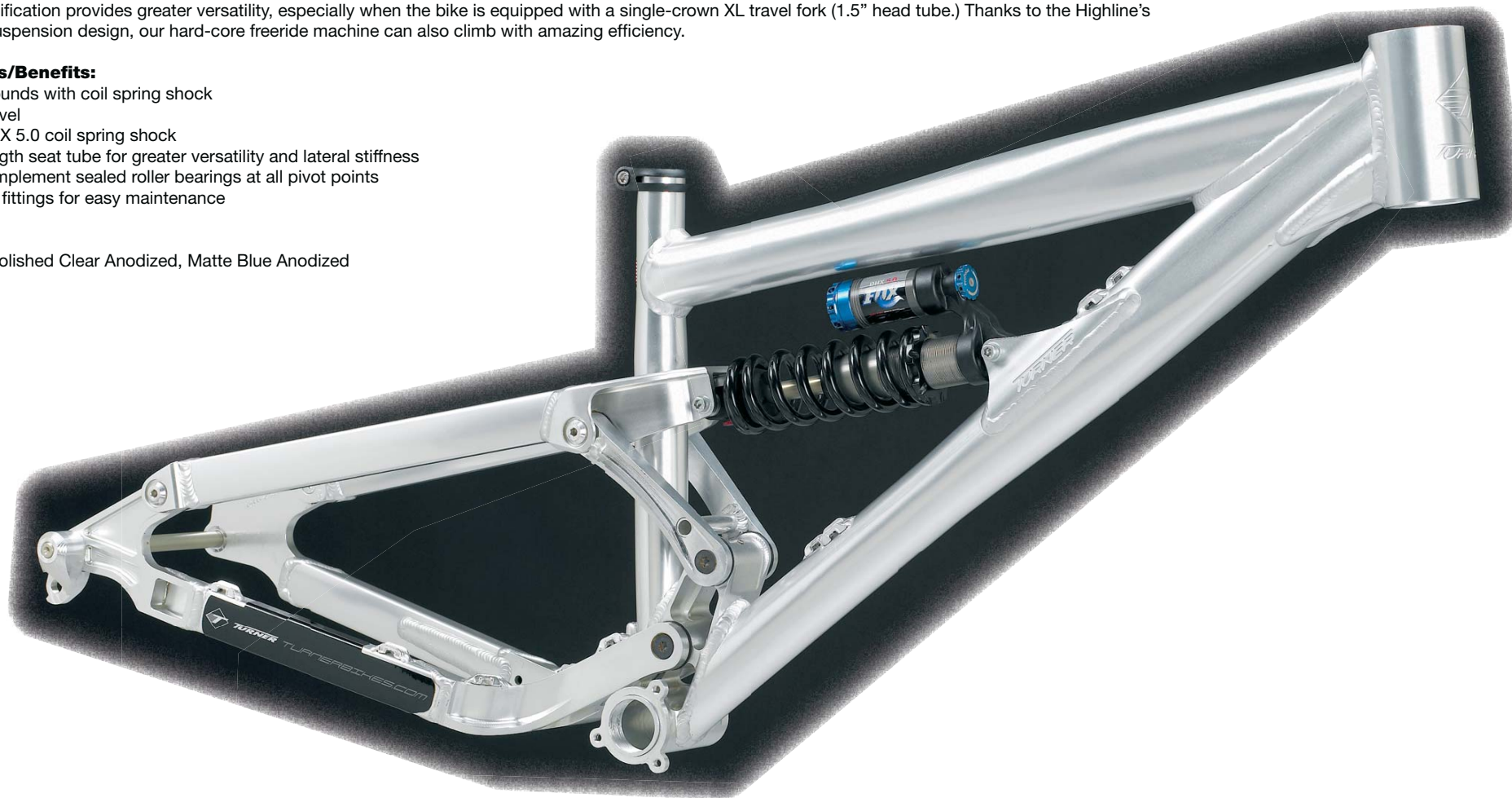

	Seat tube length	Top Tube length	Head tube length	Wheelbase	Rec'd Height	Standover height	Travel	Head angle	Seat Angle	Chainstay	BB height	Axle to crown
Small	15"	21.25"	4"	45"	< 5'6"	30.5"	7.1"	66.5°	72°	17.2"	14.6"	570mm
Medium	17"	22.75"	4.5"	46"	5'7"-5'10"	30.5"	7.1"	66.5°	72°	17.2"	14.6"	570mm
Large	19"	23.75"	5"	47"	5'11"-6"1"	31"	7.1"	66.5°	72°	17.2"	14.6"	570mm
XL	21"	25"	6"	48.25"	6'2" +	32"	7.1"	66.5°	72°	17.2"	14.6"	570mm

DHR

Purpose: Downhill racing & ride park assaults

Overview: 2007 marks the Turner DHR's seventh year on the NORBA and World Cup pro downhill race circuits. That's a lot of history to build upon, and the 2007 DHR's design showcases many years of experience and winning. The 2007 DHR's basic architecture maintains our tried-and-true 8.5" travel and proven roller bearing shock linkage. Departures from our old design include round tubing on the new model. This change saves weight without sacrificing torsional rigidity. Through extensive finite element analysis we were able to lower the 2007 DHR's weight by nearly two pounds and still meet our goals for strength. With our increased racing efforts in Europe in 2006 we were able to substantially expand our R&D input from World Cup riders. This resulted in a more compact frame for quicker handling, a reduction in BB height and a more relaxed head angle for even greater high-speed stability. Long noted for it's downhill speed, the 2007 DHR will out sprint, out corner and outlast the other downhill race frames on the market.

Features/Benefits:

- Round tubes reduce weight, maintain torsional stiffness
- Maxle rear axle comes stock, but frame is also compatible with Saint derailleur/axle assemblies
- 150mm dropout spacing reduces rear wheel dish
- Full complement roller bearing main pivot for prolonged service life
- New rear dropout design for faster axle installation and wheel changes
- Internally machined head tube is compatible with 1-1/8-inch headsets
- 83mm wide BB shell for greater high-speed stability

Color: Bright Yellow Powdercoat



	Seat tube length, direct	Top tube length, actual	Head tube length	Wheelbase	Rec'd Height	Standover height	Travel	Head angle	Seat Angle	Chainstay	BB height	Axle to crown
Small	15"	20.25"	3.7"	44.8"	< 5'6"	30.5"	8.5"	64°	N/A	17.4"	14.4"	570mm
Medium	16"	21.8"	4.2"	46"	5'7"-5'10"	30.5"	8.5"	64°	N/A	17.4"	14.4"	570mm
Large	17"	22.4"	4.7"	46.8"	5'11" +	31"	8.5"	64°	N/A	17.4"	14.4"	570mm