



**2016-2018 Focus RS BIG MOUTH LIT KIT
Ram Air Intake Installation Guide**

Kit Contents (Full Kit)

Please review this document before attempting installation.

You will need basic hand tools and about 2 hours of installation time.

Please review the table below and make sure you have received the kit contents.

Kit Contents	Qty
M6 x 30mm Cap Screw	1
M6 x 40mm Cap Screw	1
M6 Small Washer	2
M6 Lock Nuts	3
Diode Dynamics RGBW Controller	1
Positive Cable w/ In-Line Fuse	1
Power Cable w/ Pigtail Connector	1
Switch	1
Switch Ground Cable w/ Pigtail Connector	1
8" Zip Ties	8
Assembled LIT KIT BIG MOUTH	1



Kit Contents (LIT Flare Only)

Please review the table below and make sure you have received the kit contents.

Kit Contents	Qty
Diode Dynamics RGBW Controller	1
Positive Cable w/ In-Line Fuse	1
Power Cable w/ Pigtail Connector	1
Switch	1
Switch Ground Cable w/ Pigtail Connector	1
Cable Clips	2
8" Zip Ties	8
Assembled LIT Flare	1



If you already own the Velossa Tech Design GEN 4 Focus RS BIG MOUTH, skip to slide 8 to see install and wiring instructions.



Bumper Removal

For installation of the BIG MOUTH LIT KIT, you will need to remove the bumper.
For best instruction, use YouTube videos to guide you on bumper removal.

Stock Shroud Modification

Once the bumper is removed, remove the rubber radiator shroud shown below. You may choose to remove it completely if you do not want to trim. If you choose to keep it on the vehicle, you need to cut a 2"x7" opening as shown.

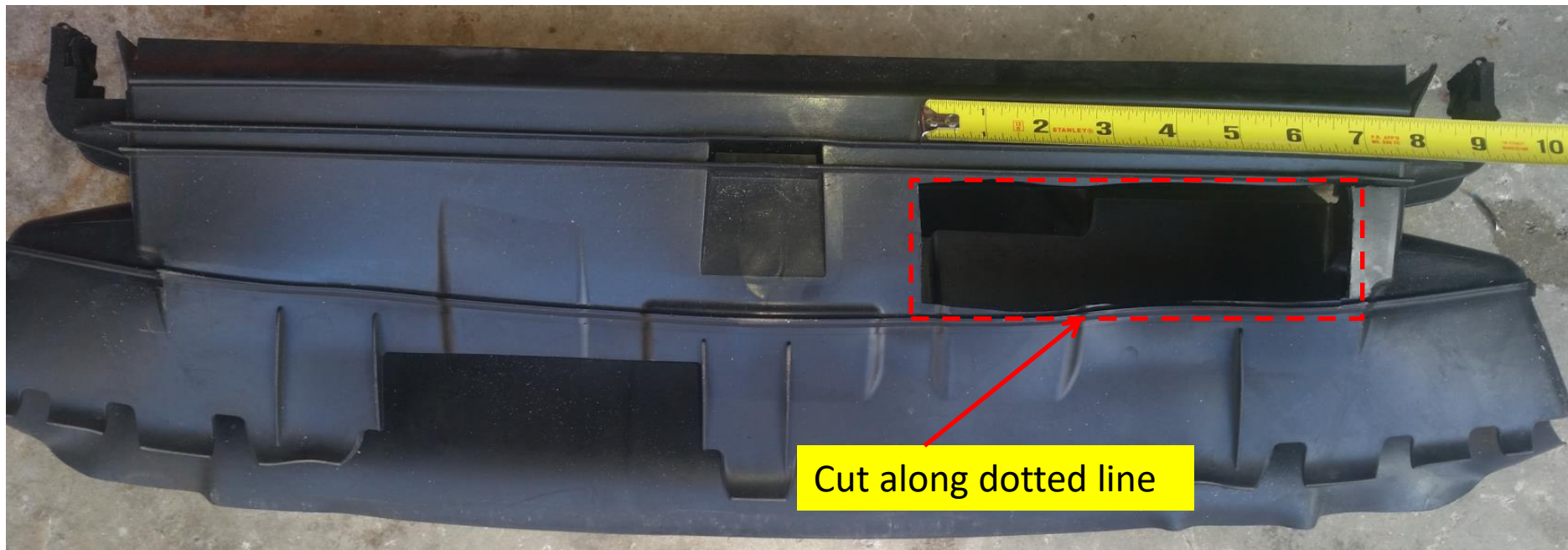

Stock Components Removal

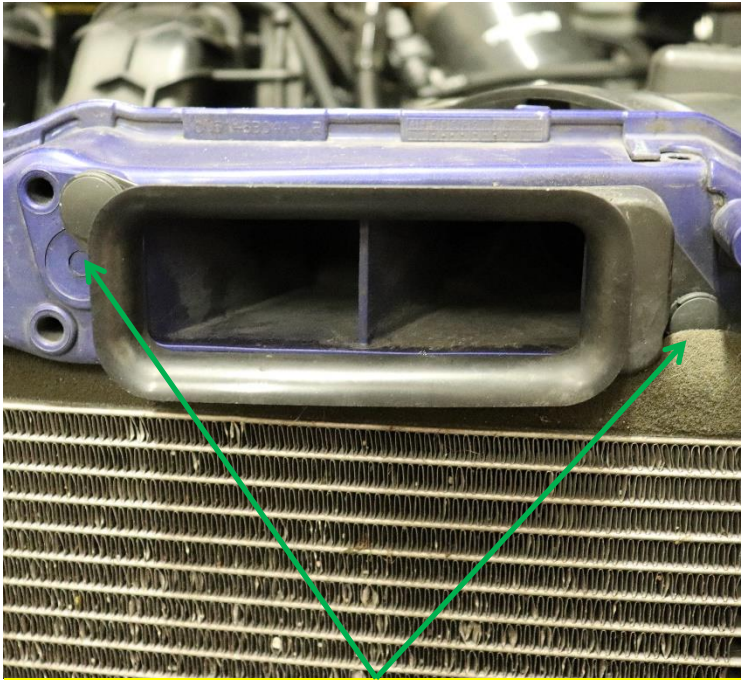

Remove pop-up clips to remove stock intake

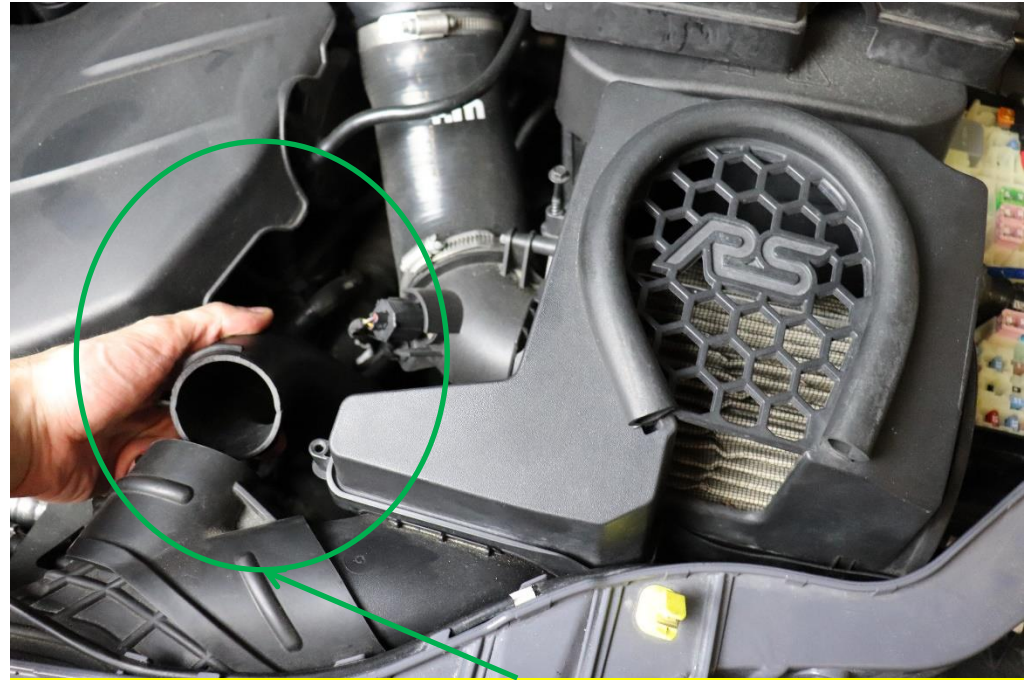

Undo the plastic tubing shown. **DO NOT DISCARD.**

Stock Components Removal

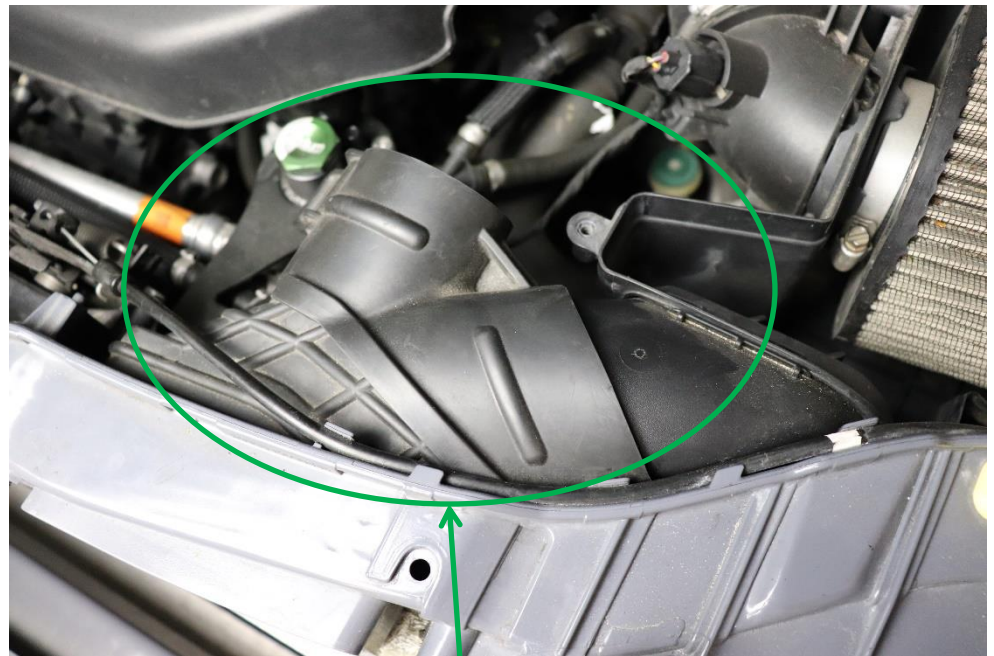
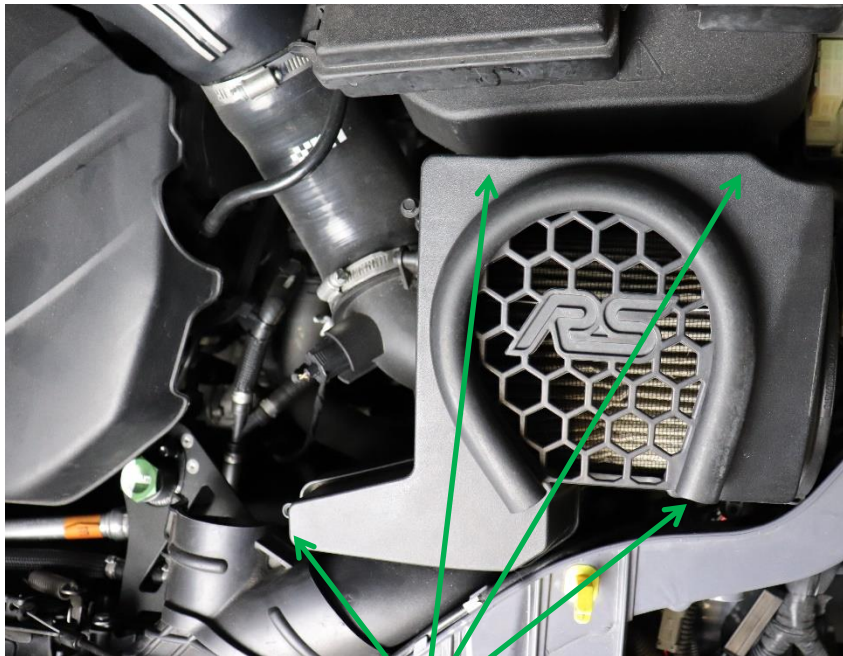

Undo the screws that retain the stock airbox casing and put aside.

Lastly, undo the assembly of plastic tubing shown to gain access to the back of the radiator shroud.
DO NOT DISCARD.

Install the LIT BIG MOUTH Flare

SKIP THIS SLIDE IF YOU PURCHASED A FULL LIT KIT

Attach the supplied cable clips to your BIG MOUTH as shown. Fasten the cable and provide enough slack to not strain the cable.



LED power cable must exit the driver side of the flare once installed!

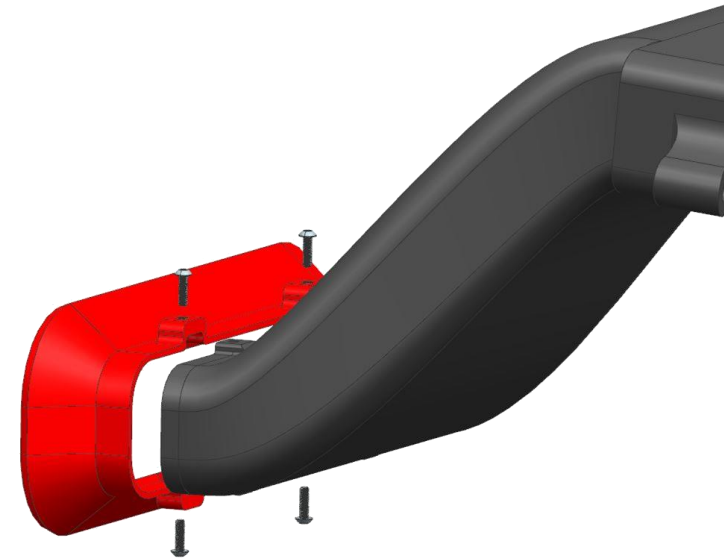

If you purchased a LIT flare-only and already have a Gen 4 BIG MOUTH. Remove old flare and install the LIT flare with the 4 screws as shown.

BIG MOUTH Installation Procedure

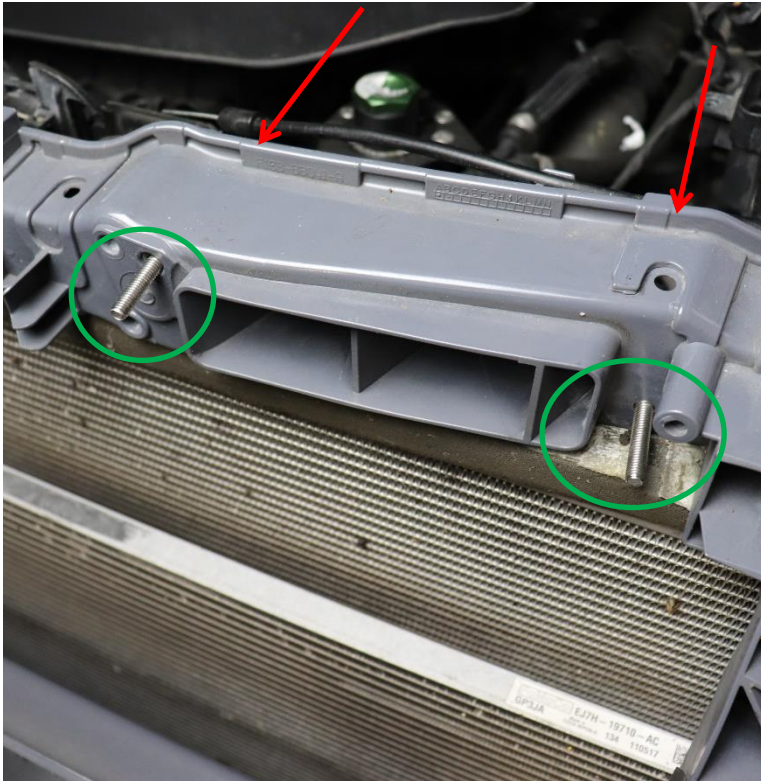

Insert bolts **from the rear** using a 5mm Allen key. **The longer bolt (M6x40mm) goes on the driver side.**

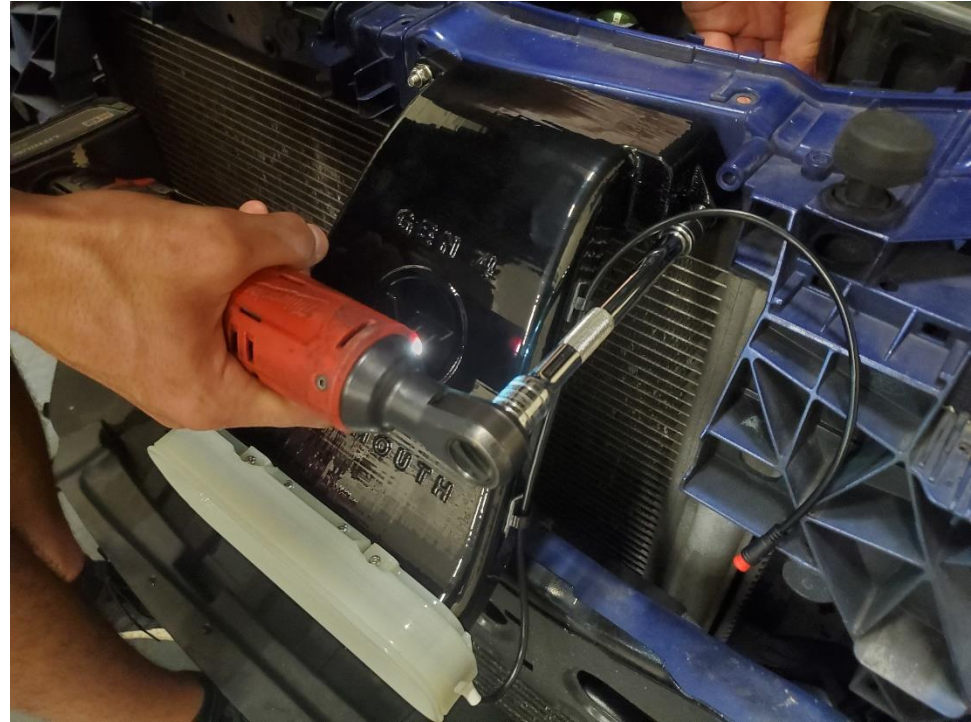

Seat the snorkel over the cowl as shown and fasten with the supplied washers and M6 lock nuts. **DO NOT OVERTORQUE.** Tighten until nut is flush with flange, then tighten extra 1/8 turn.



VELOSSA TECH

Wiring Harness

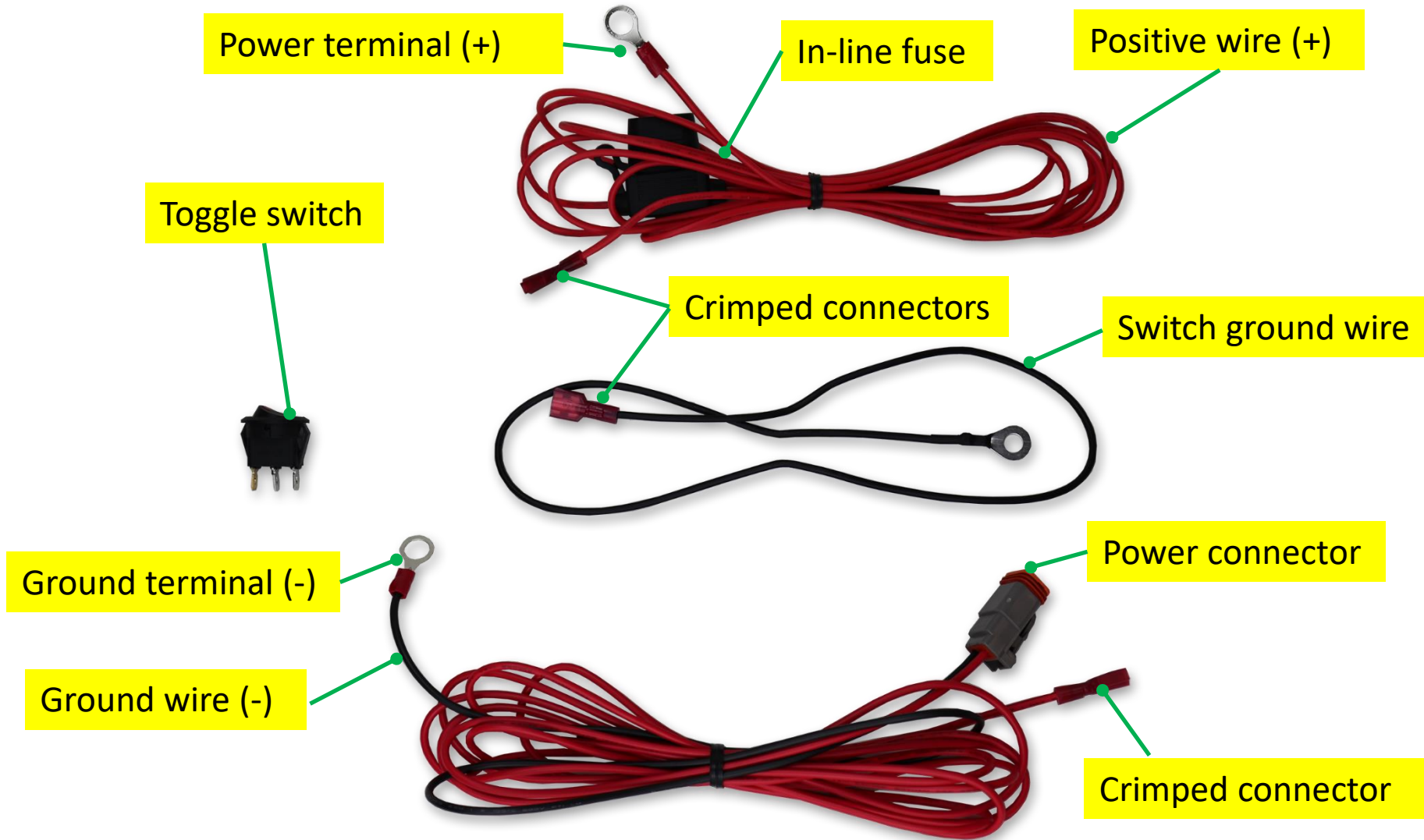



VELOSSA TECH

Wiring Harness Schematic

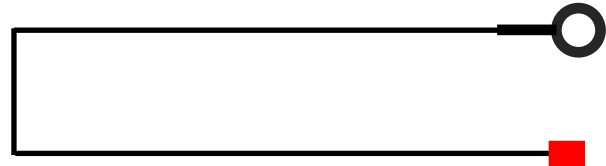
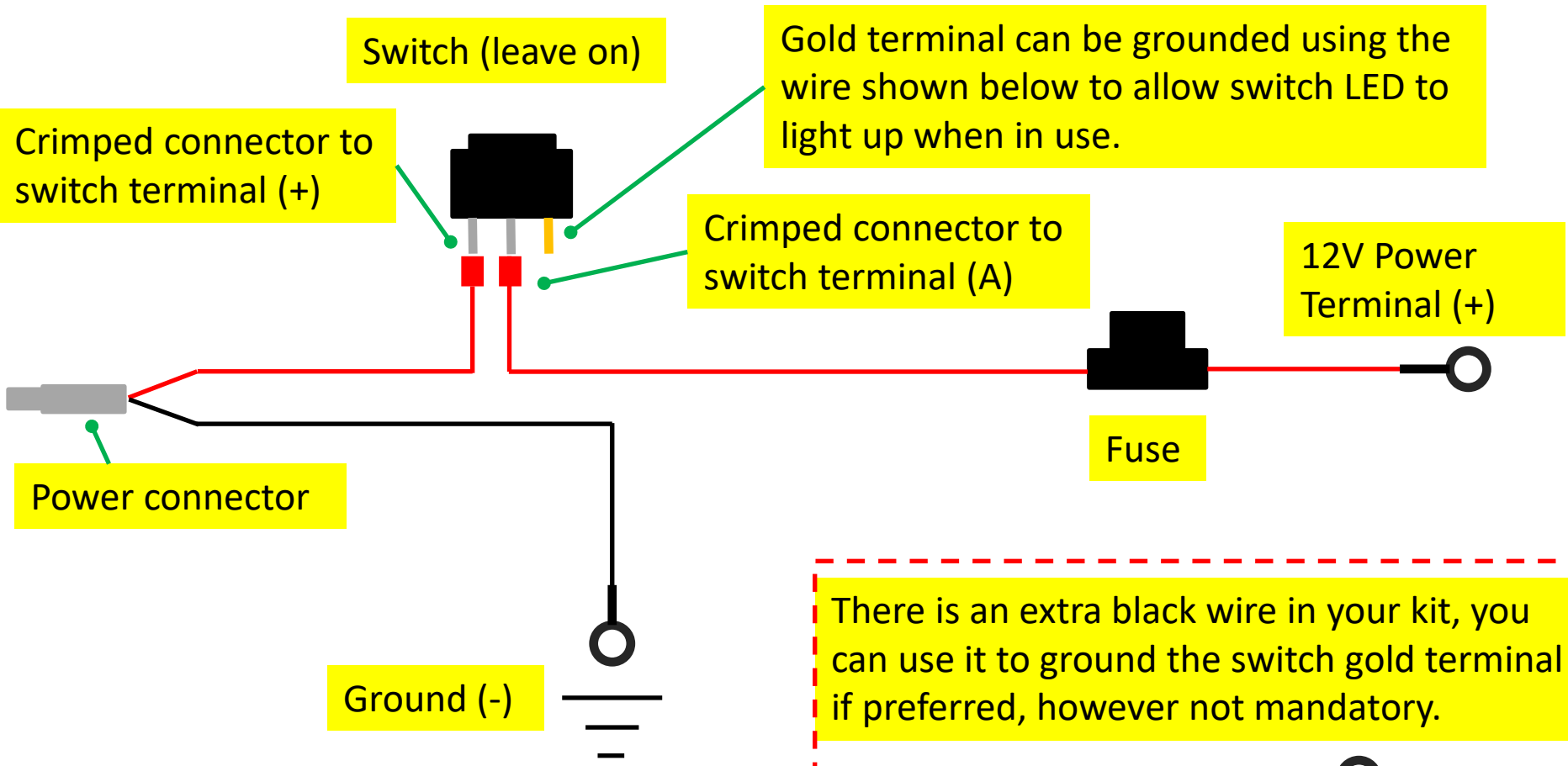

Wiring the LIT KIT

Create a bundle of power wire as shown. Leave about 1 foot of wire slack.

Grey power connector

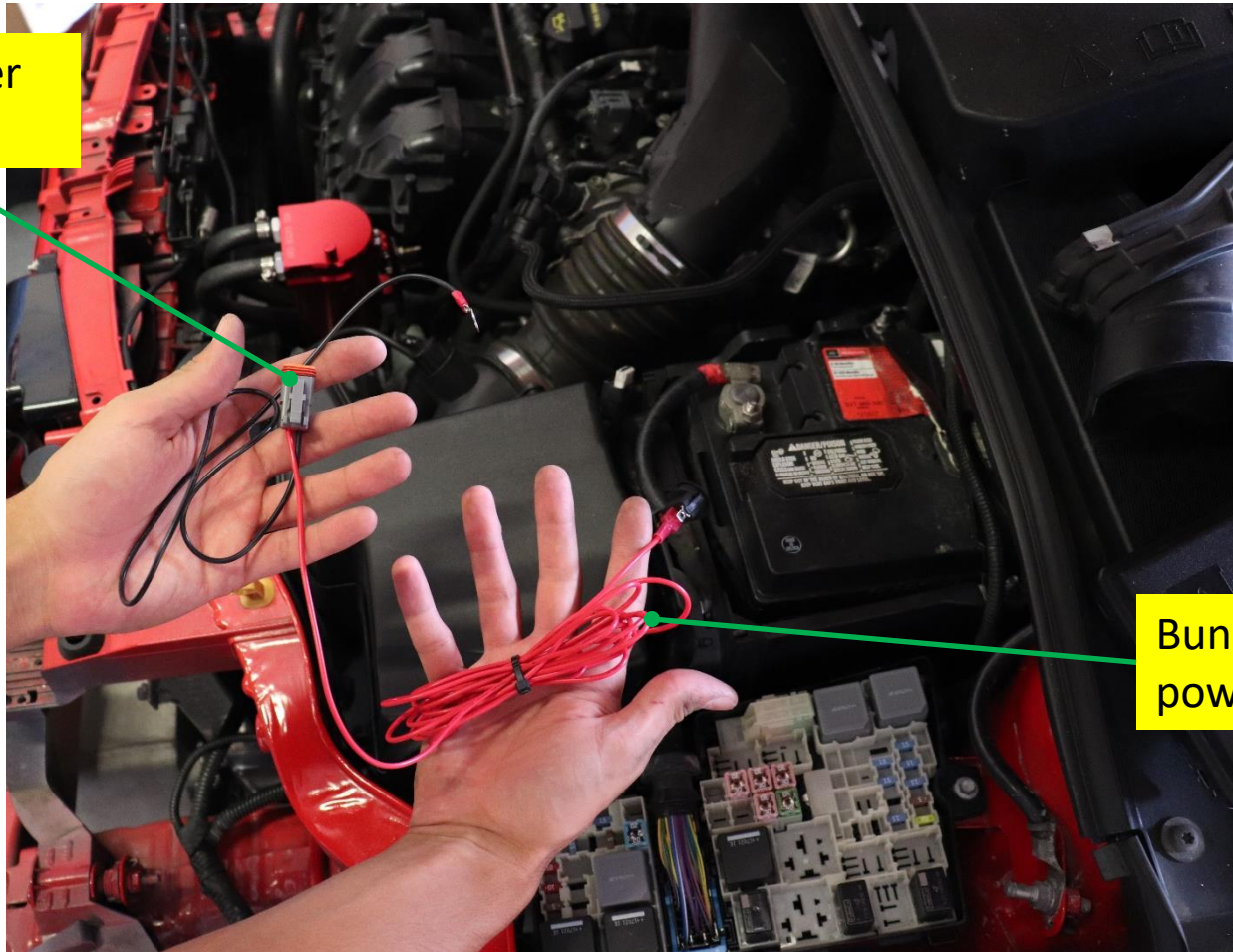

Bundle of power wire

Wiring the LIT KIT

Create a bundle of power wire as shown. Leave about 1 foot of wire slack.

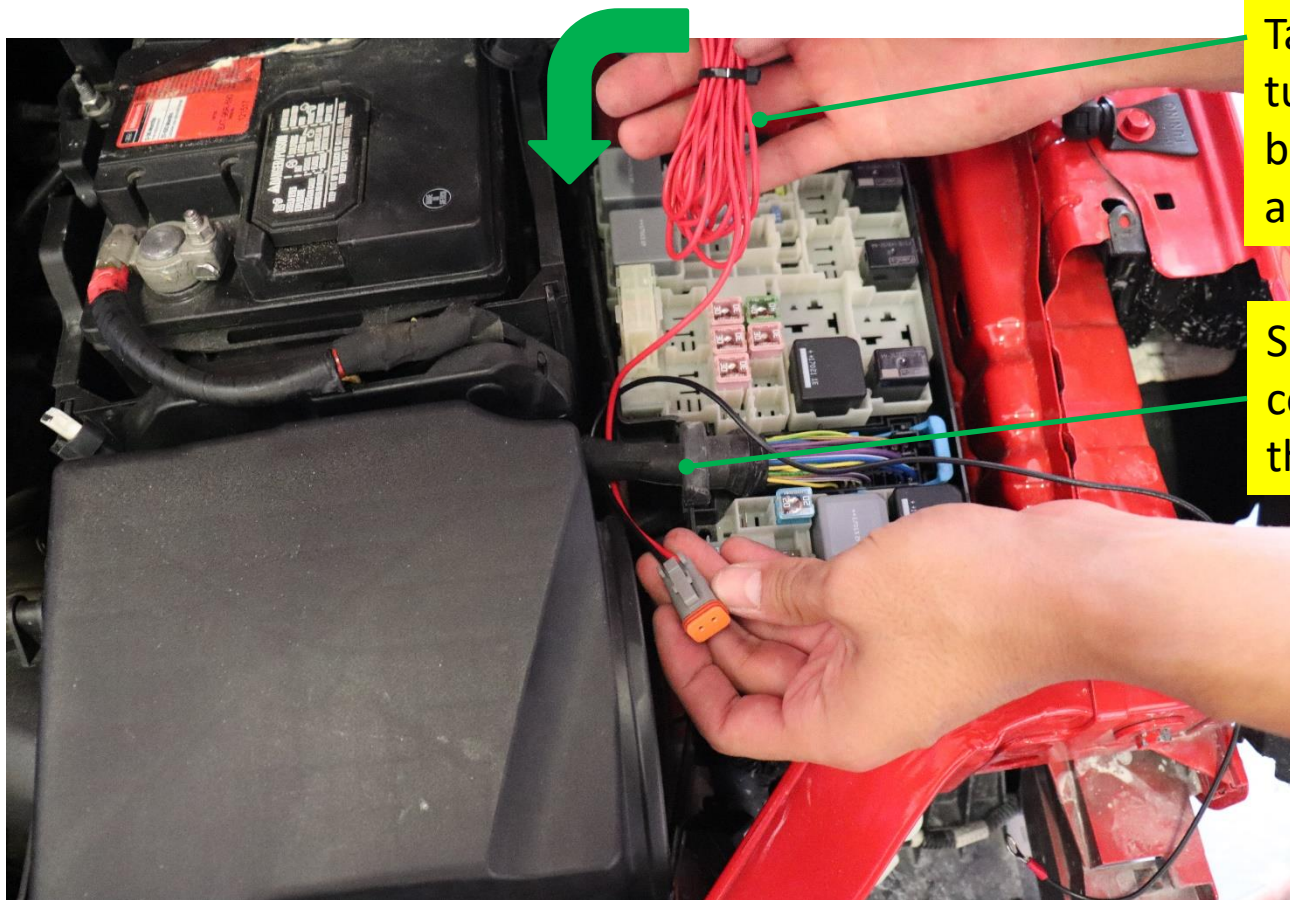

Take this bundle and tuck it in the gap between the fuse-box and battery.

Snake the power connector under this OEM harness.

Wiring the LIT KIT

Plug in the power wires to the switch as shown in the schematic on slide 10.

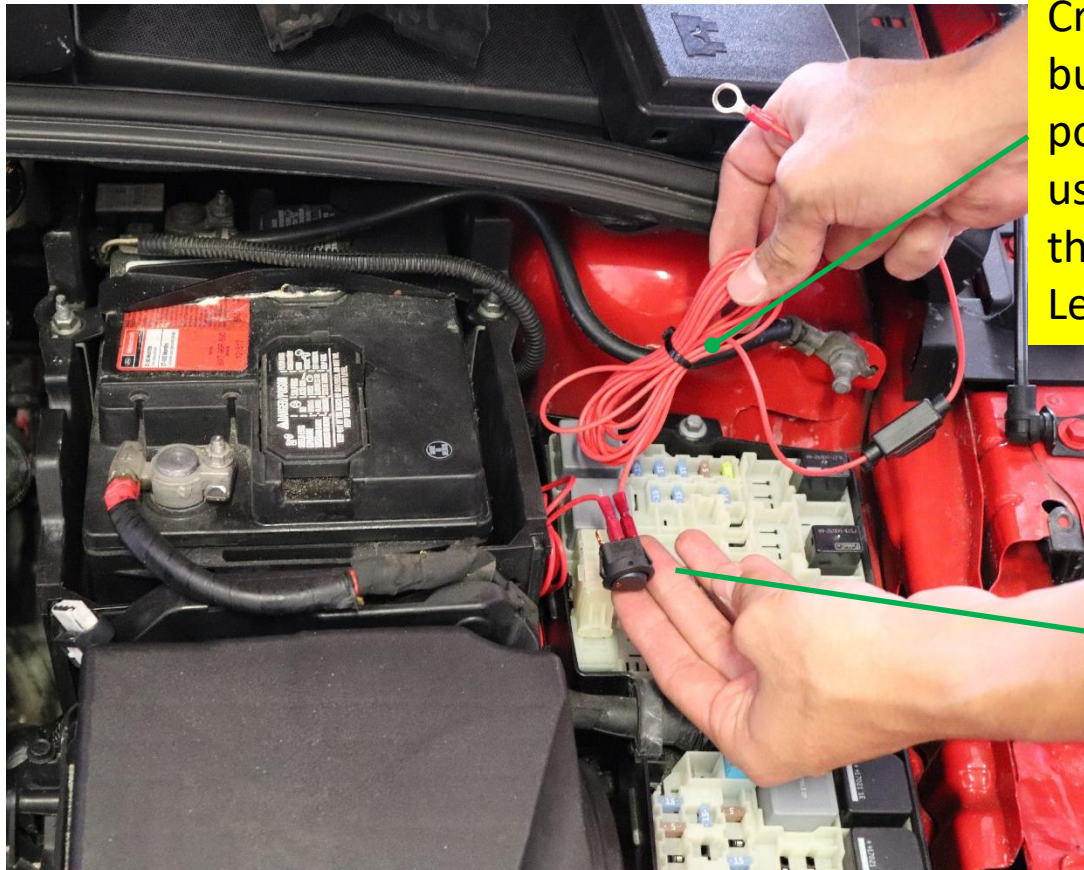

Create the second bundle for the power connection using the wire with the in-line fuse. Leave some slack.

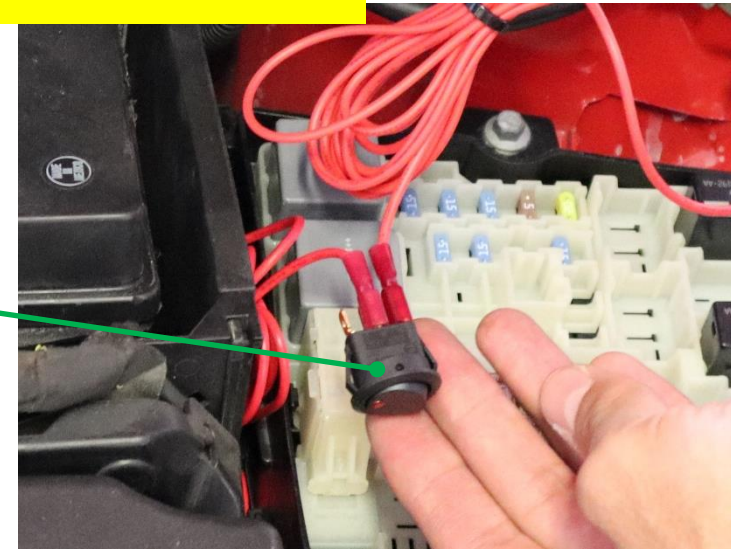

Wiring the LIT KIT

Zip tie the Bluetooth controller and power connector to the thick OEM wire harness as shown.

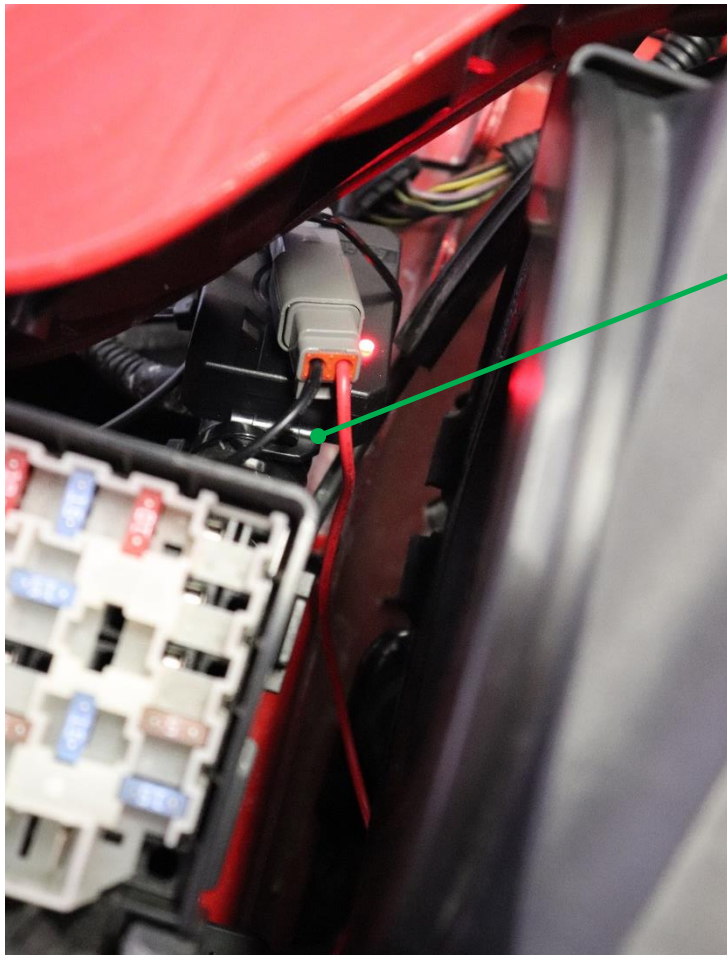

The controller and power connector are zip tied together. Use 2 zip ties; one zip tie should go through the Bluetooth controller mounting eye.



Wiring the LIT KIT

Ground the power harness black wire here.



Wiring the LIT KIT

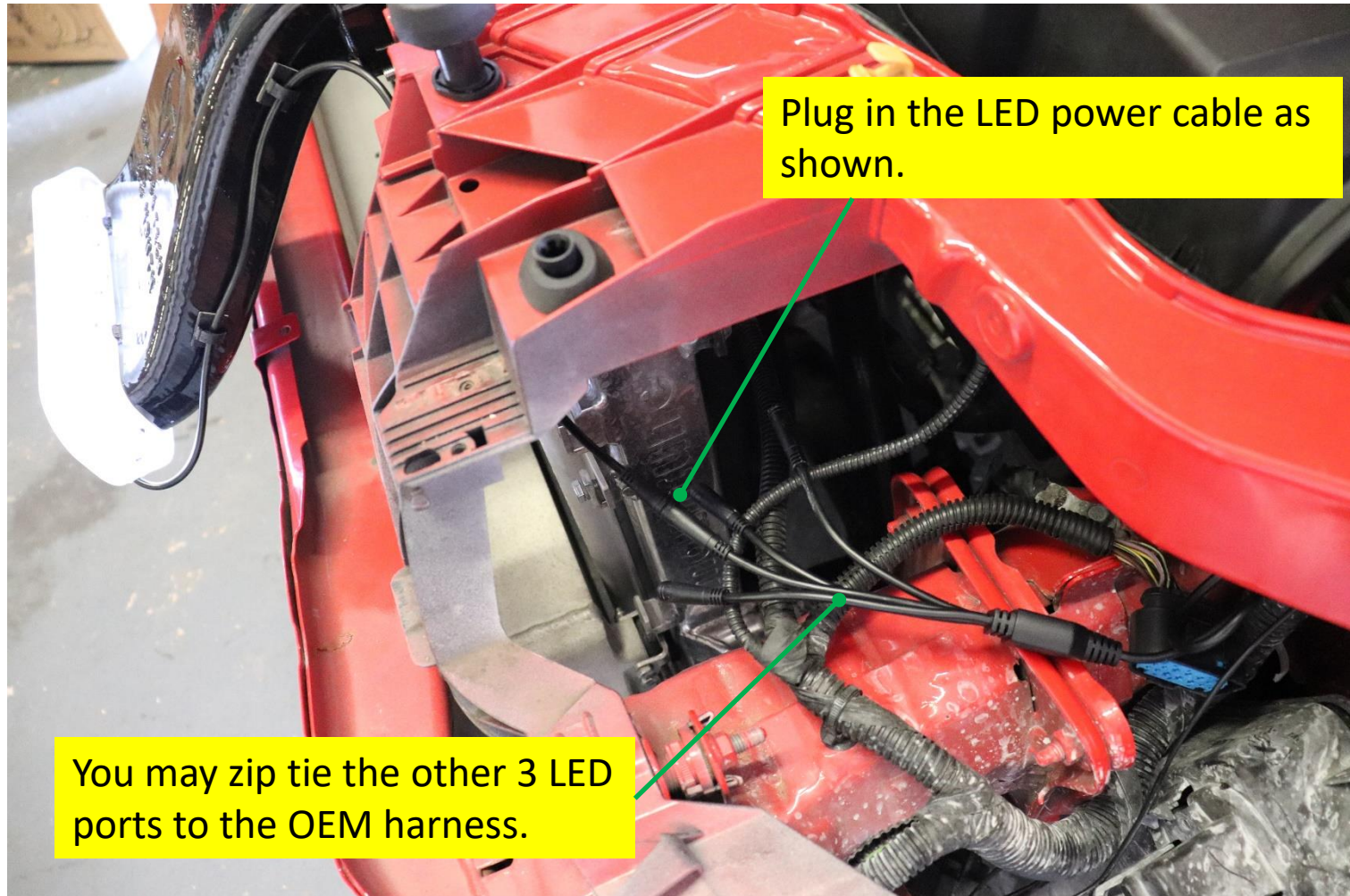

Plug in the LED power cable as shown.

You may zip tie the other 3 LED ports to the OEM harness.

Wiring the LIT KIT

You may ground the switch to the battery (-) using the short black wire.

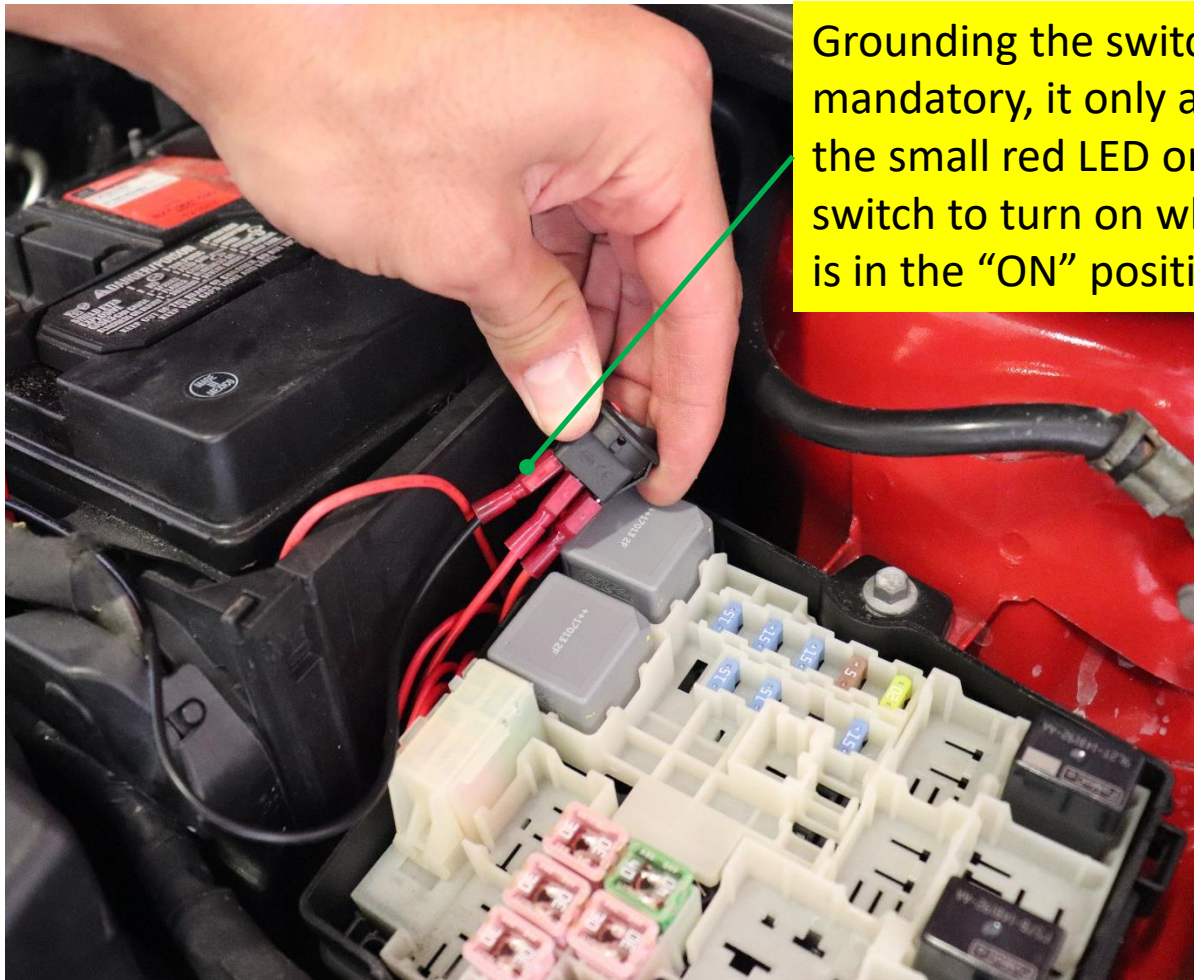

Grounding the switch is not mandatory, it only allows for the small red LED on the switch to turn on when switch is in the "ON" position.

Wiring the LIT KIT

You may tuck away the switch and excess wire between the fuse box and battery.

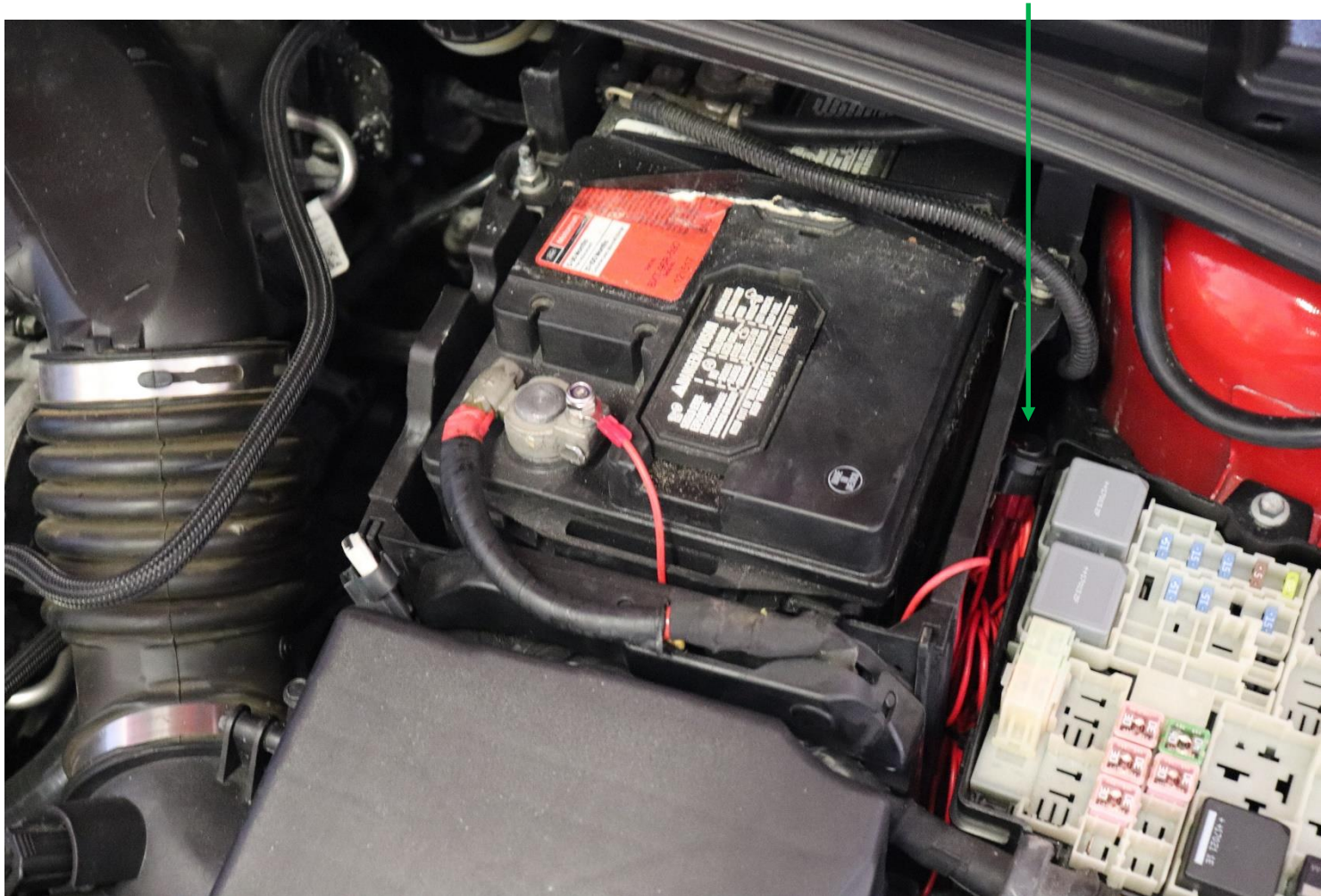

Phone App

Download the Diode Dynamics app and connect via Bluetooth.

How to connect to the app:

1. After installing the app from the app store, open the app on your device.
2. Cycle the power to the Bluetooth controller by unplugging it and plugging it back in or flick the power switch and wait a few seconds, then turn it back on.
3. Wait for the app to detect the controller, it will pop up on the app screen as a Bluetooth controller. If necessary, cycle the power once more to refresh the controller.
4. Once the controller shows up on the app, click it and connect. You have 30 seconds to select the controller once it shows up on the app. After 30 second you will need to refresh again to detect the controller again.
5. Note that if you mounted your controller behind a lot of metal components, this may degrade the signal and range.





VELOSSA TECH

Finalize

Re-install the bumper the same way it was removed and ENJOY!

