

HOPPE® 

Handle of excellence.

Lift & Slide Hardware Catalog

Edition 7

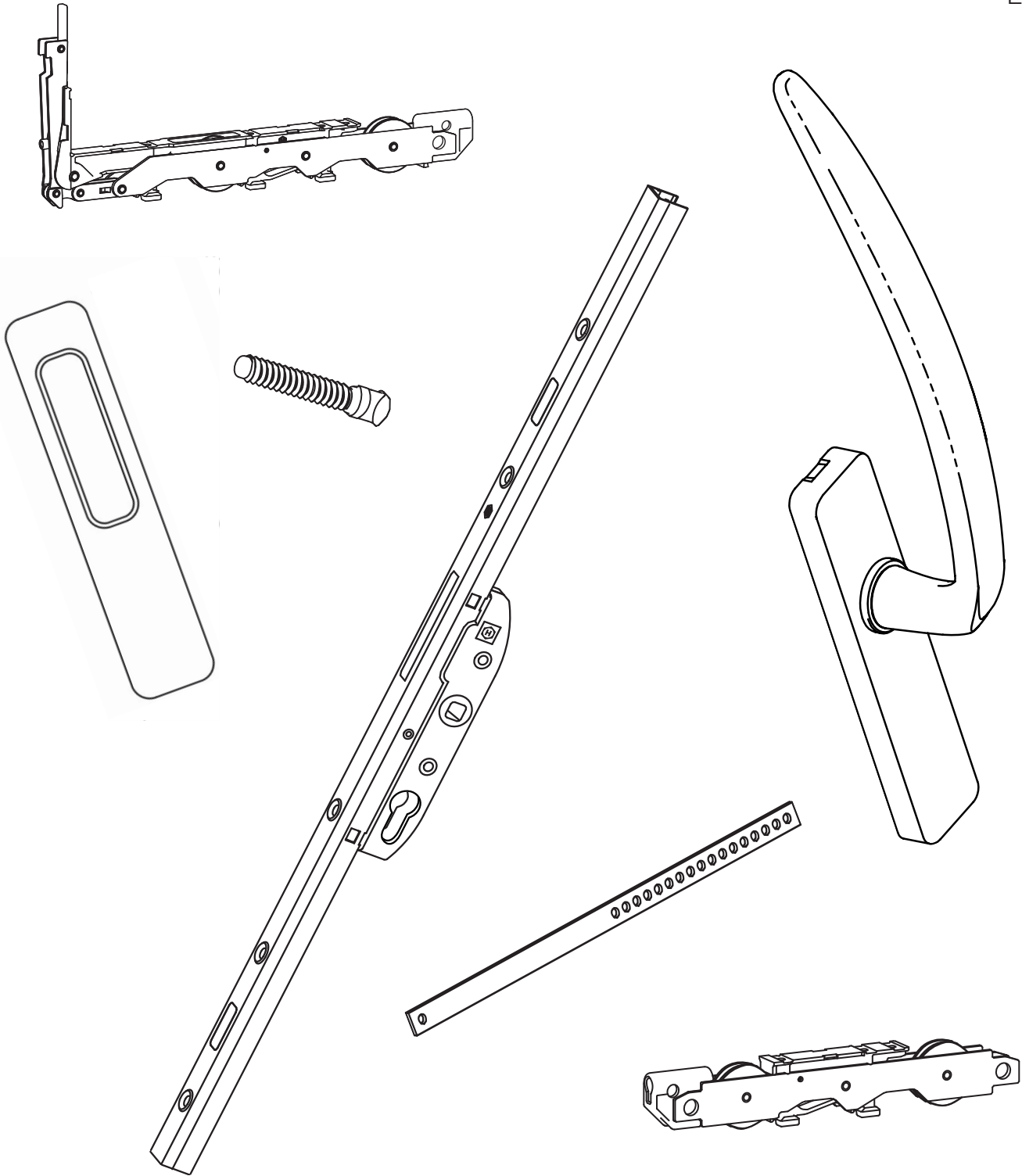

From Functional to Fabulous

All sliding patio doors serve the same basic purpose. Their primary function is to allow easy access to the deck or patio, particularly in applications where a swinging door would be less desirable. The slightly larger opening is also an added bonus when trying to move something like a new sofa into the house. But while traditional sliding doors may be an attractive option for furniture fanatics, architects and designers might be more interested in something that is just as fabulous as it is functional.

Great Room, Greater View

Lift and slide door systems can create much larger openings than traditional sliding doors. Capable of moving multiple inline panels that are more than 10' wide x 10' tall and up to 880 lbs. (440 kg) each, this system can literally make entire walls disappear. Corners aren't a problem either, as accessories are available that allow for a completely unobstructed 90° opening. Furthermore, this system can even operate on a low profile bottom rail that is embedded into the flooring making the transition between great room and great view nearly seamless. The architectural possibilities are almost endless with lift and slide doors.

Weighing in on Functionality

But how could anyone ever move such mammoth panels? If you've ever tried to operate a typical sliding door that has experienced some wear on the rollers and seal, you can imagine how it would be impossible to move that door if it was 880 lbs. The answer is, ironically, that you must first lift that heavy panel before sliding it. It really is easier than it sounds.

Traditional sliding doors move on rollers in a track. The door panel itself also rides within that track, dragging along and fighting the weather stripping the entire way. When the rollers aren't adjusted properly or the track becomes damaged or dirty, the friction increases and the door drags even more. Lift and slide doors are different. By simply turning the lever handle 180°, the panel is easily lifted completely off the track, clear of any weather stripping or debris. The result is a smooth gliding door that can be moved with the touch of a finger.

To return the door to a stationary position, the handle is used again to retract the bogie wheels and lower the panel. The wheels are now protected from excessive wear, and the panel weight compresses the gaskets for a weather tight seal.

Expansive spaces, effortless operation and exceptional protection against the elements are just a few of the reasons lift and slide doors are becoming more and more popular.



Dallas handle in Satin Nickel - Page 25

Why HOPPE's Lift & Slide Hardware?

- The only Lift & Slide hardware that is manufactured by HAUTAU and brought to you by HOPPE, a combination with more than 150 years of experience in providing quality craftsmanship and impeccable service.
- HOPPE's QUICK SHIP stocking program means standard components ship faster -- within 2 weeks for most orders.
- Panels weighing up to 968 lbs. (440 kg) can be moved effortlessly with the push of a finger.
- Entire walls can disappear with sash sizes up to 10'7" (3235 mm) wide by 10'9" (3300 mm) tall and a frame width up to 21'4" (6500 mm).
- Three Guide Track designs, two finishes, and multiple configurations are available to suit almost any design and application.
- An optional low profile running rail creates a seamless transition between interior and exterior spaces and provides barrier free accessibility.
- Cleaning brushes are a standard feature on the highly corrosion resistant bogie wheels. The brushes clean the track with every pass extending the life of the components and ensuring a consistently smooth slide.
- Specially coated components provide excellent corrosion resistance even in coastal environments.
- Dual-position locking bolts allow the door to be slightly open for ventilation, but still remain locked for security.
- Installation is easy with prefabricated components, and options are available for wood, vinyl, or aluminum panel construction.
- HOPPE Lift and Slide Handles provide the finishing touch.
- Matching designs and finishes are also available for Swing Door and Window applications for a coordinated look throughout the home.

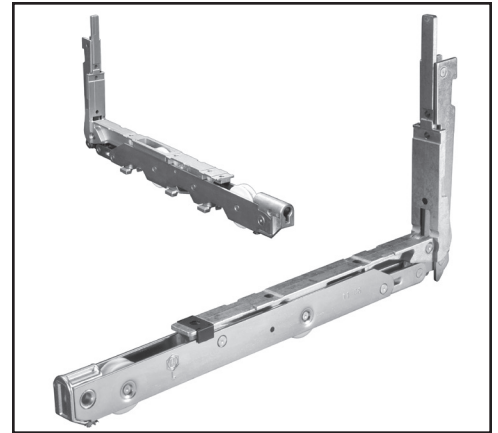

HS 330 & optional HS 200 Front Bogies - Page 12

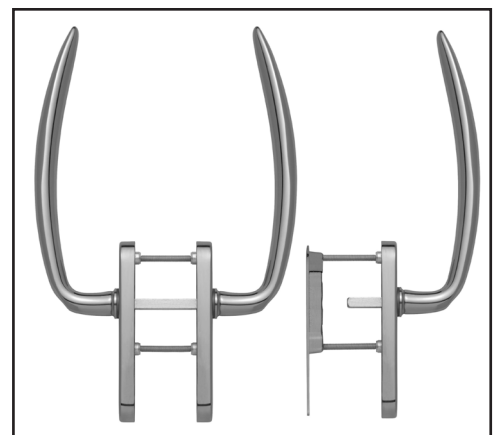

Atlanta handle in Satin Nickel Resista® - Page 24

Frequently Asked Questions

Question:

What are the advantages of Lift & Slide?

What is the HOPPE QUICK SHIP program?

What is the maximum weight capacity of this system?

What are the min/max panel sizes for this hardware?

Is the hardware corrosion resistant?

What is the price of the system?

Are preparation drawings and installation instructions available?

Are jigs available?

Can I order individual components from the accessory kits?

What is the bogie wheel material?

Is this hardware compatible with specific vinyl and aluminum profiles along with wood?

What is the warranty?

Can I get electronic systems?

What are the different Profiles?

Can we use 8 mm rods instead of connecting rods?

Answer:

Lift & Slide doors provide smoother, easier operation. Heavy panels are moved with the push of a finger. Weather sealing is optimized because seals are compressed when the panel is lowered.

The HOPPE QUICK SHIP program features our most popular Lift & Slide hardware items. These items are targeted to ship in two weeks or less!

968 lbs. Please see information on HS 440 Bogie Wheels found in this catalog.

25.6" (650 mm) to 127.4" (3235 mm) in width, 47.2" (1200 mm) to 123" (3300 mm) and higher in height. Panel size depends on selected hardware.

Yes. The hardware items feature technology and finishes designed to resist corrosion even in coastal applications.

Lift & Slide from HOPPE is competitively priced, providing an optimal cost to benefit ratio. Please contact your HOPPE sales representative for pricing.

Yes. Drawings and instructions for standard configurations are given in this catalog. Information on non-standard configurations is available by request.

Yes. Information on jigs is provided in this catalog including part numbers for ordering.

Requests are considered on a case-by-case basis. Minimum order quantities may apply.

Wheels are made from glass reinforced nylon.

Yes. Our Applications Staff will review your profile drawings to find the best hardware solution.

Warranty information is available on our website: www.US.HOPPE.com.

Requests are considered on a case-by-case basis.

The differences are measured by the door thickness and the air gap. The standard thickness is 2.20" (56mm) and air gap is 0.39" (10mm). Another common door thickness is 2.67" (68 mm) and air gap is 1.10" (28 mm).

Yes. Upon request. Will use the hex head screws instead of the dowel pins.

Range of Application depends on profile system.

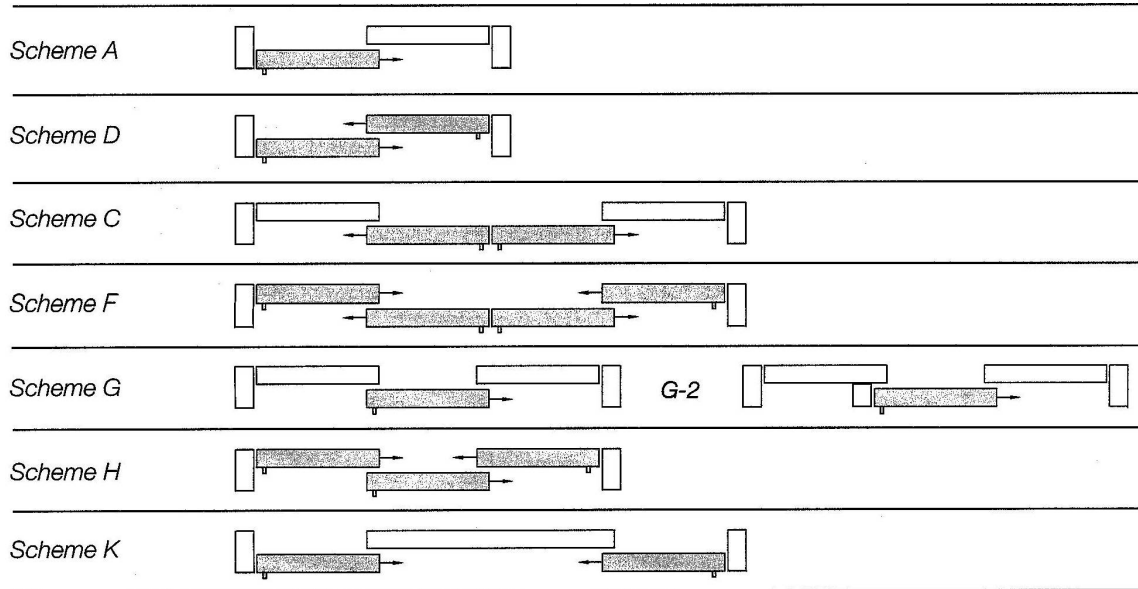

Tokyo series handle in Silver - Page 25

System Overview (Shown using Guide Track 1 & Running Rail 26. Other configurations available.)

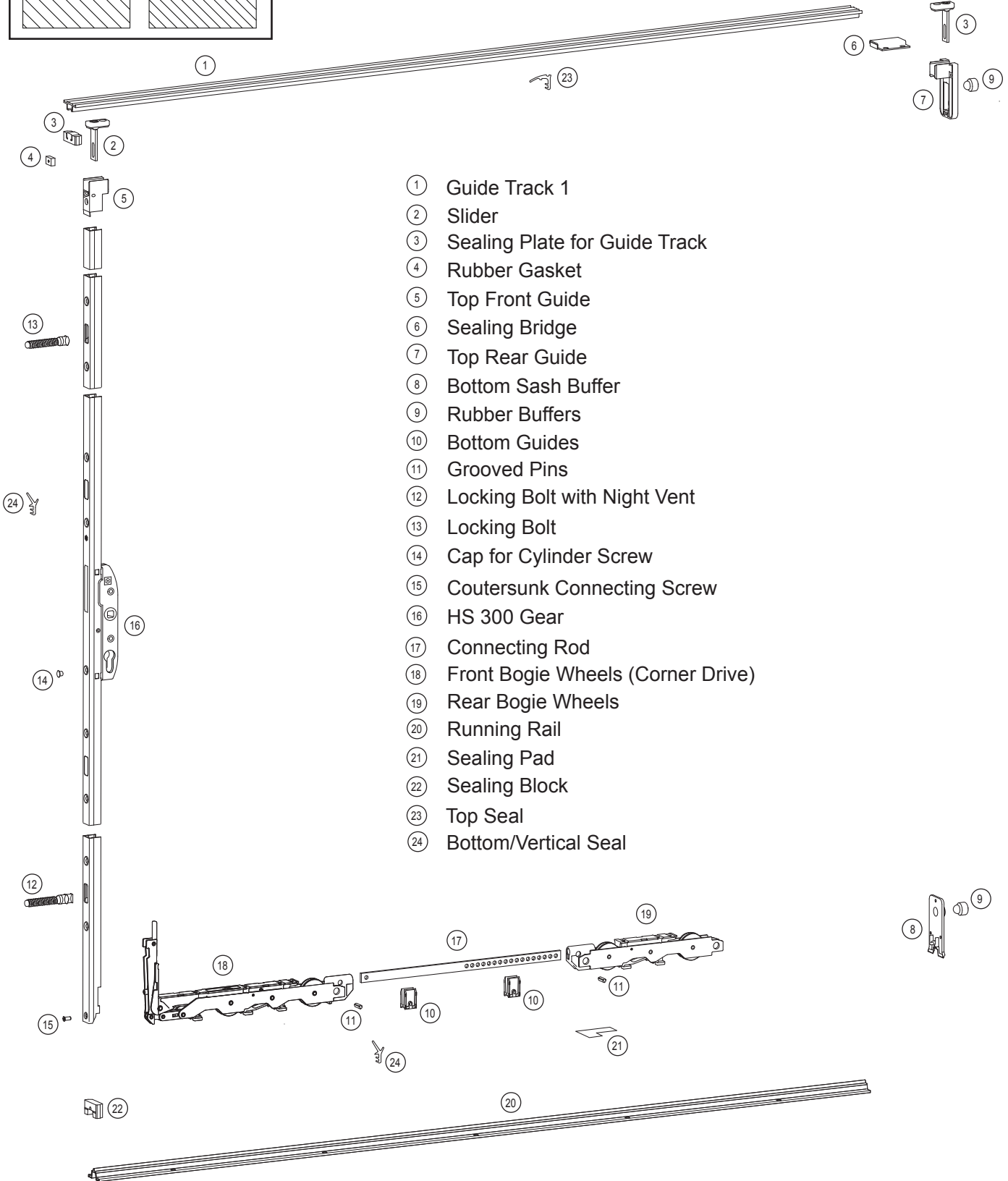
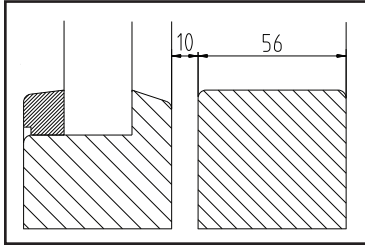

- ① Guide Track 1
- ② Slider
- ③ Sealing Plate for Guide Track
- ④ Rubber Gasket
- ⑤ Top Front Guide
- ⑥ Sealing Bridge
- ⑦ Top Rear Guide
- ⑧ Bottom Sash Buffer
- ⑨ Rubber Buffers
- ⑩ Bottom Guides
- ⑪ Grooved Pins
- ⑫ Locking Bolt with Night Vent
- ⑬ Locking Bolt
- ⑭ Cap for Cylinder Screw
- ⑮ Countersunk Connecting Screw
- ⑯ HS 300 Gear
- ⑰ Connecting Rod
- ⑱ Front Bogie Wheels (Corner Drive)
- ⑲ Rear Bogie Wheels
- ⑳ Running Rail
- ㉑ Sealing Pad
- ㉒ Sealing Block
- ㉓ Top Seal
- ㉔ Bottom/Vertical Seal

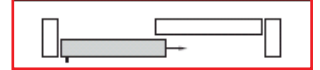

HS 330 Lift & Slide QUICK SHIP
Standard Configuration

56/10



How To Order

Step 1: Choose Your Guide Track & Accessory Kit...

Position	Description	Item Number	Qty/Opening
1 and 2 - 15	 Guide Track 1, Size 3500, 11'5" (3500 mm) Length, Chestnut	40000825	1
	Accessory Kit for Guide Track 1, 56/10	3902595	
	 Guide Track 5, Size 3500, 11'5" (3500 mm) Length, Silver	40005355	
	Accessory Kit for Guide Track 5, 56/10	40006384	

Step 2: Choose Your Gear Size...

Position	Description	Panel Height	Item Number	Qty/Opening
16	HS 330 Gear, Chestnut			1
	Size 210	5'11" - 6'10" (1801 - 2100 mm)	3183797	
	Size 240	6'11" - 7'10" (2101 - 2400 mm)	3183818	
	Size 270	7'11" - 8'10" (2401 - 2700 mm)	3183834	

Step 3: Choose Your Connecting Rod Size...

Position	Description	Panel Width	Item Number	Qty/Opening
17	Connecting Rod			1
	Size 150	2'5" - 4'10" (720 - 1500 mm)	3183842	
	Size 200	4'11" - 6'6" (1501 - 2000 mm)	3183851	

Step 4: Add Your Running Rail, Wheels and Seals...

Position	Description	Item Number	Qty/Opening
18 - 19	HS 330 Bogie Wheel Kit	40005008	1
20	Running Rail 26, Size 3500, 11'5" (3500 mm) Length, Silver	3188838	1
21 - 22	Sealing Pad & Sealing Block Kit	3191906	1
23	Top Seal	3184327	1
24	Bottom/Vertical Seal	3184335	1

All Items on this page are QUICK SHIP Standard product targeted to ship within 2 weeks.

Please refer to the System Components section for additional options and finishes. Items designated as QUICK SHIP items are targeted for shipment within 2 weeks, for orders up to 5 openings. Lead times for larger orders and non-QUICK SHIP items will vary.

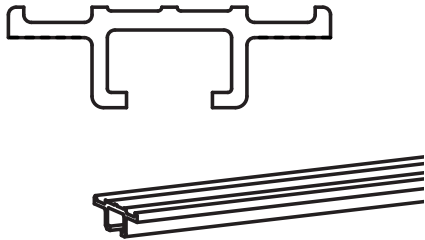

① Guide Track 1

- Silver or Chestnut Finish
- Use with Accessory Kit shown below

Length	Finish	Item Number
9'10" (3000 mm)	Silver	40000758
11'5" (3500 mm)	Silver	40000765
14'9" (4500 mm)	Silver	40000783
21'4" (6500 mm)	Silver	40000801

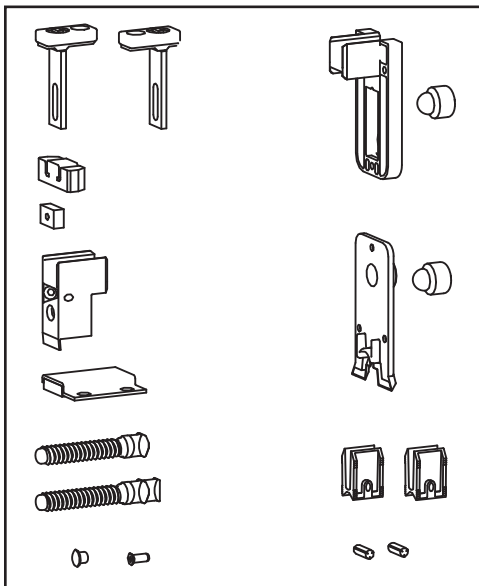

Refer to Page 6 for Component Positions.

②-⑮ Accessory Kit for Guide Track 1



Item Number 3902595

- Grey Finish (where applicable)
- For HS330 68/10, 68/28, or 78/28 System
- Includes:
 - (2) Sliders
 - (1) Sealing Plate for Guide Track
 - (1) Rubber Gasket
 - (1) Top Front Guide
 - (1) Sealing Bridge
 - (1) Top Rear Guide
 - (1) Bottom Sash Buffer
 - (2) Rubber Buffers
 - (2) Bottom Guides
 - (2) Grooved Pins
 - (2) Locking Bolts (1 Standard & 1 Night Vent)
 - (1) Cap for Cylinder Screw
 - (1) Countersunk Connecting Screw



Indicates the item is a HOPPE **QUICK SHIP** item and is targeted for shipment within 2 weeks, for orders up to 5 openings.

Optional Guide Track 5

- Silver Only
- Typically used in configurations with multiple sliding panels
- Must use Accessory Kit for Guide Track 5 P/N 3882985

Length	Finish	Item Number
9'10" (3000 mm)	Silver	40005343
11'5" (3500 mm)	Silver	40005355
13'1" (4000 mm)	Silver	40005367
14'9" (4500 mm)	Silver	40005379
18'0" (5500 mm)	Silver	40005380
21'4" (6500 mm)	Silver	40005392

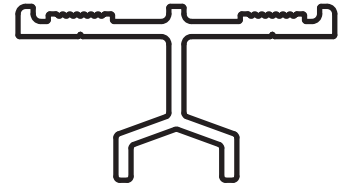

Accessory Kit for Guide Track 5



Item Number 40006384

- Grey Finish (where applicable)
- For HS330 56/10, 56/28, 68/10, or 68/28 System
- Includes:
 - (1) Sealing Plate for Guide Track
 - (1) Rubber Seal
 - (1) Top Front Guide
 - (1) Sealing Bridge
 - (1) Top Rear Guide
 - (1) Bottom Sash Buffer
 - (2) Rubber Buffers
 - (2) Bottom Guides
 - (2) Grooved Pins
 - (2) Locking Bolts (1 Standard & 1 Night Vent)
 - (1) Cap for Cylinder Screw
 - (1) Countersunk Connecting Screw

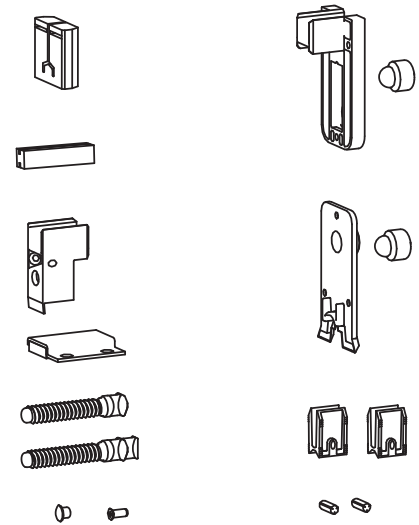

Refer to Page 6 for Component Positions.

⑩ HS 330 Gear

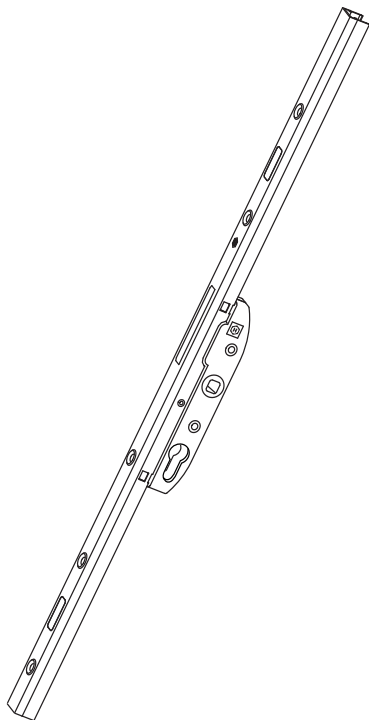

- Chestnut Finish
- 1.48" (37.50 mm) Backset
- Supplied with slots for 1 Upper and 1 Lower Locking Bolt
- Additional slots may be opened to accept 2 more Locking Bolts
- Additional Locking Bolts for frame sold separately. See below for Item Number to order.
- Extension available (see below) for doors up to 10'9" (3300 mm) tall

Size	Panel Height	Handle Height	Finish	Item Number
210	5'11" - 6'10" (1801 - 2100 mm)	1010mm (39.76")	Silver	3183789
			Anodized Black	40008545
240	6'11" - 7'10" (2101 - 2400 mm)	1010mm (39.76")	Silver	3183800
			Anodized Black	40008551
270	7'11" - 8'10" (2401 - 2700 mm)	1010mm (39.76")	Silver	3183826
			Anodized Black	40008563

Optional Gear Extension



- 1'11" (600 mm) Length
- For doors up to 10'9" (3300 mm) tall, when used with Size 270 Gear
- 1 Locking Position
- May be used with both HS 330 and HS 200 Gears
- Additional Locking Bolt for frame not included. See next page for Item Number to order.

Finish	Item Number
Silver	3373654
Chestnut	3551553

Indicates the item is a HOPPE QUICK SHIP item and is targeted for shipment within 2 weeks, for orders up to 5 openings.

Optional Gear Cover Plate

- 1'11" (600 mm) Length
- Filler plate for above Gear when Extension is not used
- No Locking Positions

Finish	Item Number
Silver	3422621
Chestnut	3393612

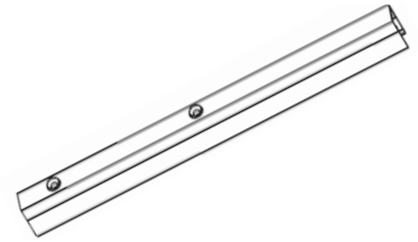

Additional Locking Bolt

Item Number 3184343

- Does not include night vent feature
- 1 Locking Bolt per package
- For use when additional locking points are used on Gear or with Gear Extension



Item Number 3493189

- Night Vent locking bolt
- 1 Locking Bolt per package
- For use when additional locking points are used on Gear or with Gear Extension



Item Number 3534761

- Surface mounted locking bolt
- 1 Locking Bolt per package
- For use when additional locking points are used on Gear or with Gear Extension



Optional Security Interlock

Item Number 3549445

- Silver Finish
- For .394" (10 mm) panel clearance
- 8'3" (2520 mm) Length
- See page 19 for dimensions and installation reference

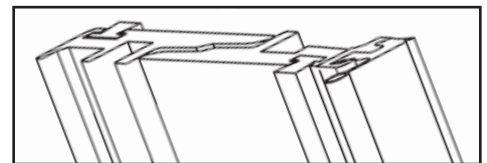

Jigs

Preparation	Item Number
Handle, with stop	3185178
Key - Locking Bolt (wood profiles)	3185194
Center Punch (wood profiles)	3185215



Please see the
Installation Reference Pages
(pages 16-21)
for drawings of each Jig and
where it is used.

System Components

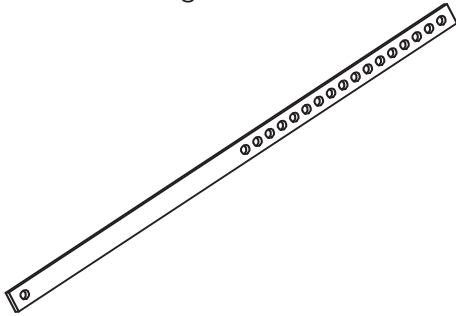
Connecting Rod



17 Connecting Rods

Size	Panel Width	Item Number
150	2'5" - 4'10" (720 - 1500 mm)	3183842 
200	4'11" - 6'6" (1501 - 2000 mm)	3183851 
250	6'7" - 8'2" (2001 - 2500 mm)	3183869

FRONT HS330 BOGIE

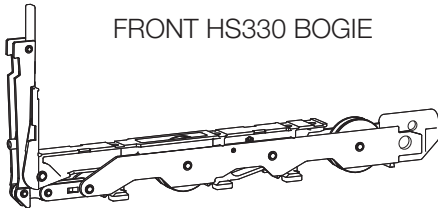

REAR HS330 BOGIE

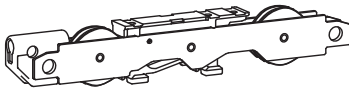

HS200 PROFILE

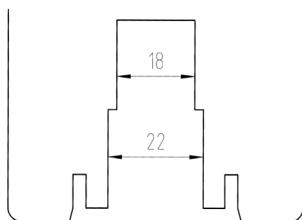

18-19 HS 330 Bogie Wheel Kit

Item Number 40005008

- Includes Front Bogie Wheels (Corner Drive) & Rear Bogie Wheels
- Maximum Panel Weight 727 lbs. (330 kg)
- Steel, S++ Finish
- Track Brushes
- Designed for use with either flat connecting bar or round rods

Grooved Pins and Countersunk Connecting Screw not included. See Accessory Kit on page 8 for these items.

Optional HS 200 Bogie Wheels (Not Shown)

Item Number 3184861

- Same as above, but Maximum Panel Weight is 440 lbs. (200 kg)
- Use with HS 330 Gear
- Important Note: Groove preparation is different than HS 330. Please see graphic at right.

Optional HS 440 Bogie Wheels

Item Number 40005264

- Pair of additional Bogie Wheels to be used in combination with the HS 330 Front & Rear Bogie Wheels
- Increases Maximum Panel Weight of HS 330 system from 727 lbs. (330 kg) to 968 lbs. (440 kg)
- Includes everything needed for connection to the system:
 - (2) Bogie Wheel Carriages
 - (4) Grooved Pins
 - (2) Short Connecting Rods

Optional Adjustable Bogie

Item Number 40005409

- Includes Front Bogie Wheels (Corner Drive) & Rear Bogie Wheels
- Vertically adjustable bogie
- Maximum Panel Weight 727 lbs. (330 kg)
- Steel, S++ Finish
- Track Brushes
- Both Corner and Bogie have brushes on them
- Designed for use with either flat connecting bar or round rods
- Adjustable from 5.5mm to 6.5mm.

Grooved Pins and Countersunk Connecting Screw not included. See Accessory Kit on page 8 for these items.

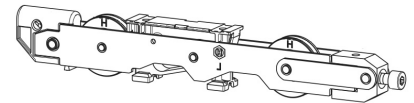
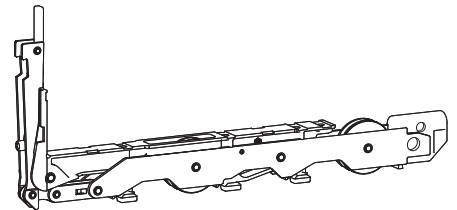
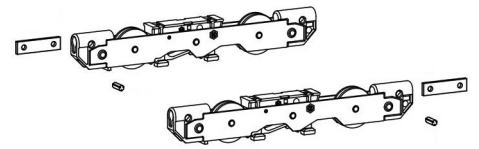

Sash in mounted condition

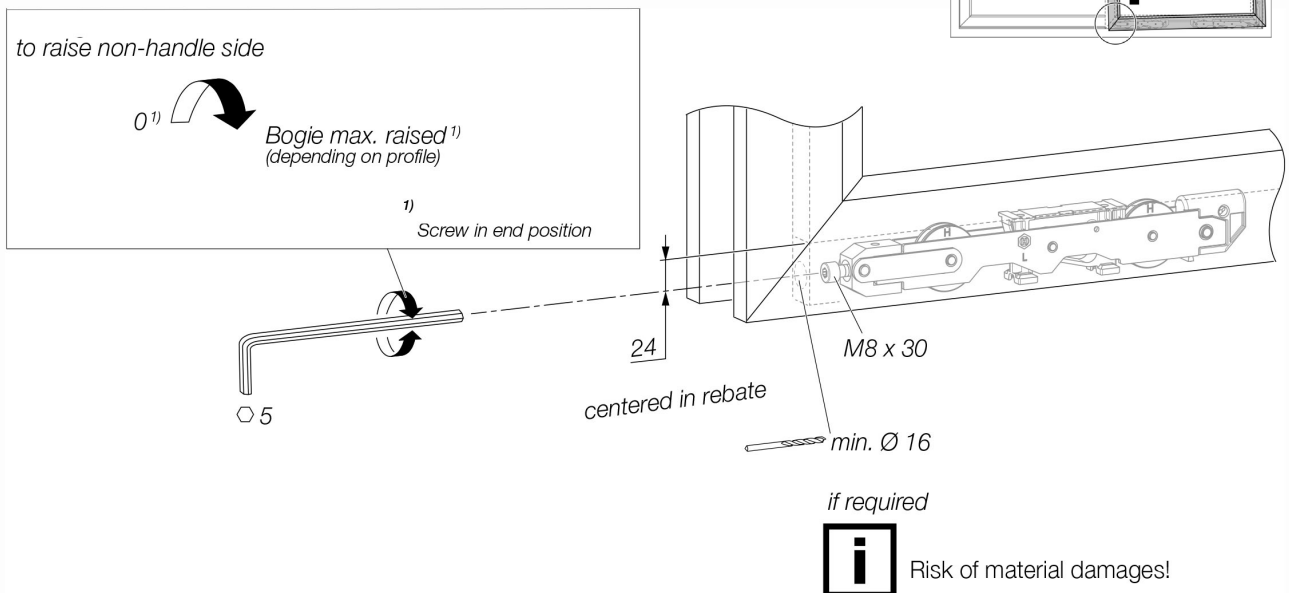
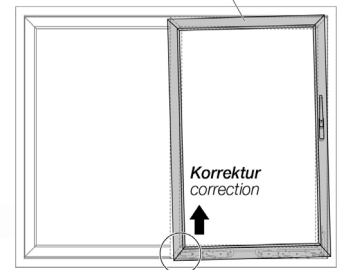

Note: All measurements are indicated in millimetres.

System Components

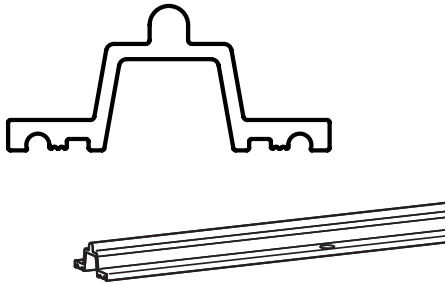

②① Running Rail 26

- Silver aluminum Finish
- For use with a wood threshold

Length	Finish	Item Number
9'10" (3000 mm)	Silver	3188820
11'5" (3500 mm)	Silver	3188838
14'9" (4500 mm)	Silver	3184301

Optional Running Rail 27 (Low Profile)

- Silver aluminum Finish
- Typically used without a threshold



Length	Item Number
9'10" (3000 mm)	3188854
11'5" (3500 mm)	3188862
14'9" (4500 mm)	3188871
21'4" (6500 mm)	3188897

②①-②② Sealing Pad & Sealing Block Kit



Item Number 3191906

- Includes:
 - (1) Sealing Pad
 - (1) Sealing Block
- Sealing Block is designed for use with Running Rail 26, but may be trimmed for use with Running Rail 27
- For use with both 2.2" (56mm) and 2.68" (68 mm) profiles

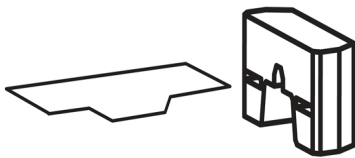

TOP



BOTTOM / VERTICAL

②③&②④ Seals



Top Seal - Item Number 3184327

- 10.73' (3250 mm) long

Bottom/Vertical Seal - Item Number 3184335

- 57.09' (17300 mm) long



Indicates the item is a HOPPE **QUICK SHIP** item and is targeted for shipment within 2 weeks, for orders up to 5 openings.

Gear Damper

Item Number 40001398

- Provides controlled motion when lowering the door panel
- Includes installation instruction



Comfort Close

- **Note:** The Comfort Close option only works with Tracks 1, 3 and 6.

Gear (265 in image)

Item Number 40001738

Less than 441 lbs (200 kg)

Item Number 40001745

Between 441 lbs to 661 lbs (200 kg - 330 kg)

Accessory Pack (268 & 269 in image) for all profiles

Item Number 40001751

- Automatically catches and closes the door panel the last 4"
- Two versions depending on panel weight
 - Size 1: 5.6 lbf
 - Size 2: 11.2 lbf
- Features adjustment of ± 5 mm to alter catch position

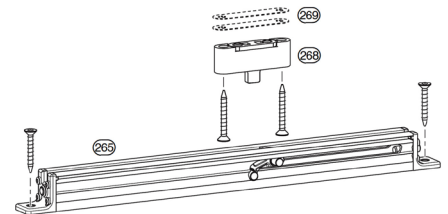

For vinyl profiles please contact a HOPPE representative.



Indicates the item is a HOPPE **QUICK SHIP** item and is targeted for shipment within 2 weeks, for orders up to 5 openings.

56/10

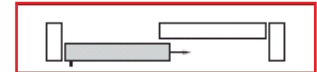
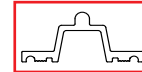

WITH GUIDE TRACK 1

WITH GUIDE TRACK 5

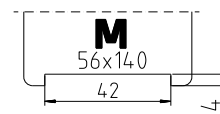
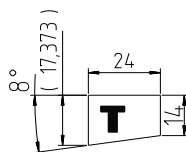
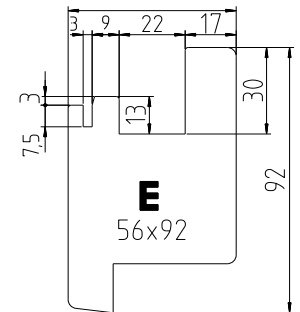
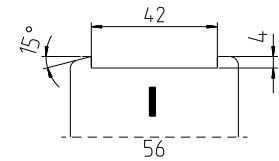
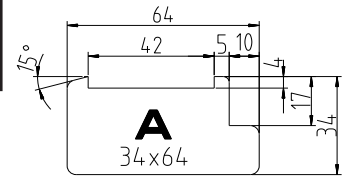
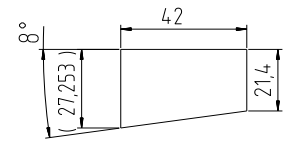
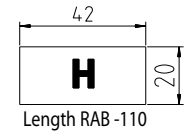
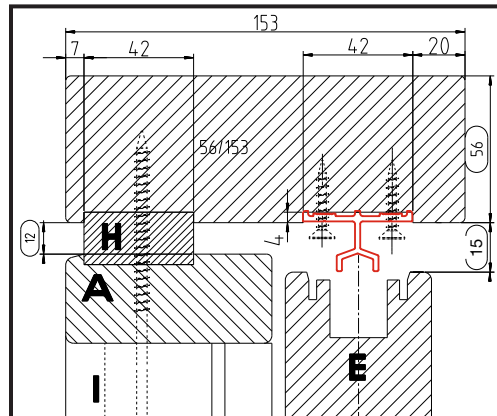
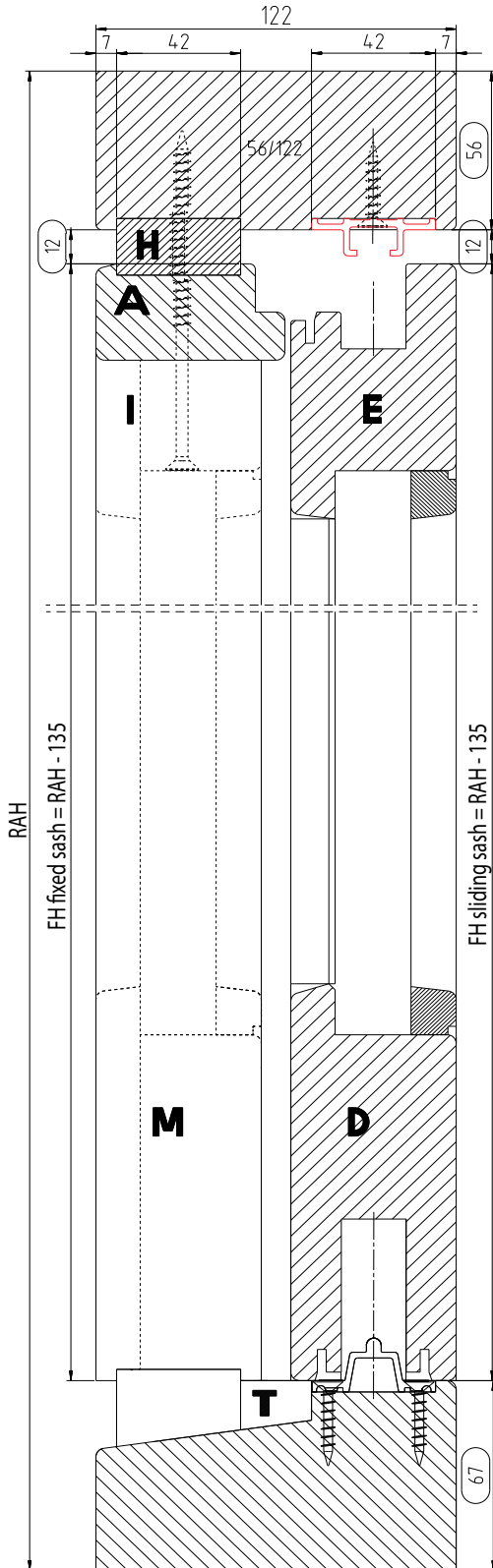

Profile section M = Profile section D with groove 42 x 4

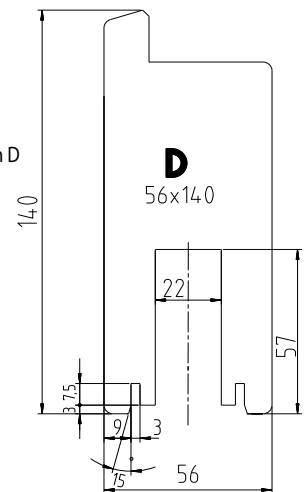
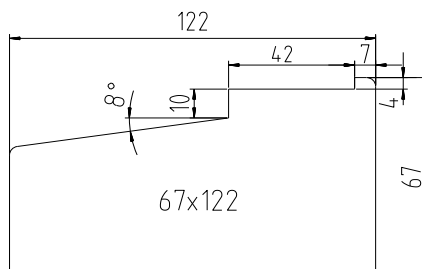

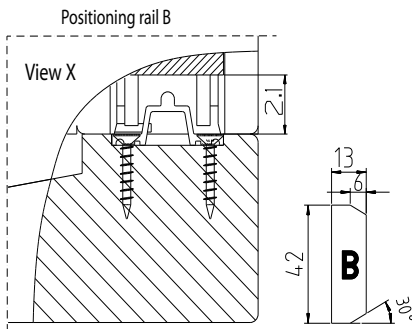
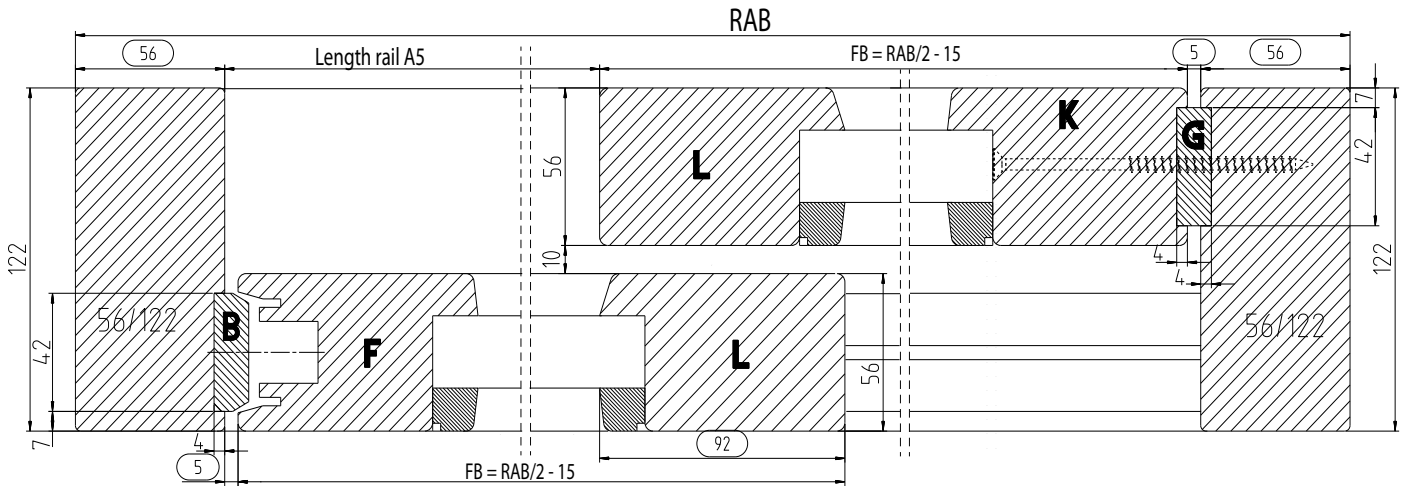

Length rail B = RAH - 157 (FH-22)
 Length rail B (handicapped accessible) = RAH - 147 (FH-12)

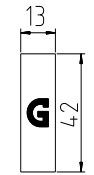
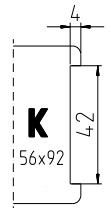
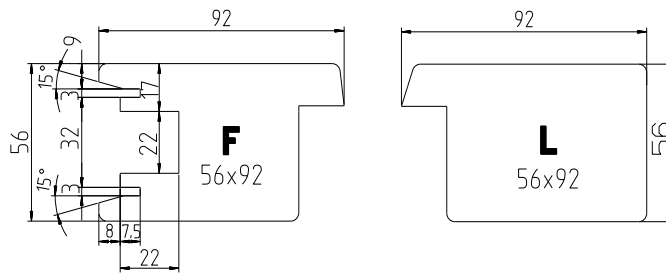

Length FH - 10

IMPORTANT:

- See sections A-A and B-B for jamb dimensions
- Calculated dimensions for construction assume dimensions given in \bigcirc are maintained

FB	=	Sash Width
FH	=	Sash Height
RAB	=	Outer Frame Width
RAH	=	Outer Frame Height

All dimensions on pages 14-15 shown in millimeters. All drawings and dimensions for reference only. Actual designs may vary. 1" = 25.4mm

1.0

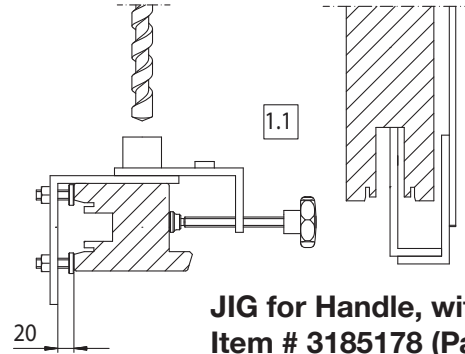
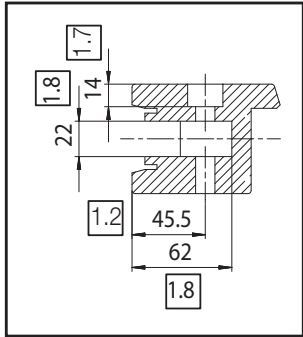

**JIG for Handle, with Stop,
Item # 3185178 (Page 11)**

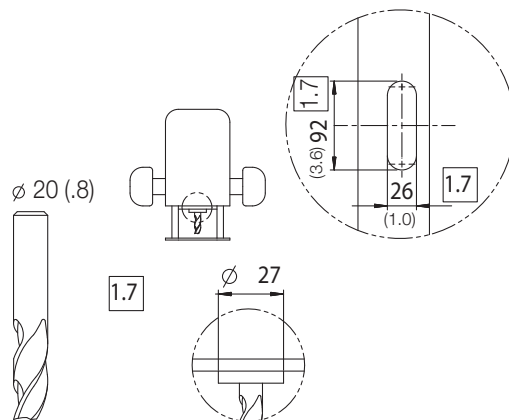
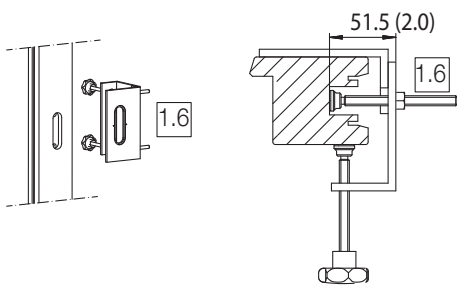
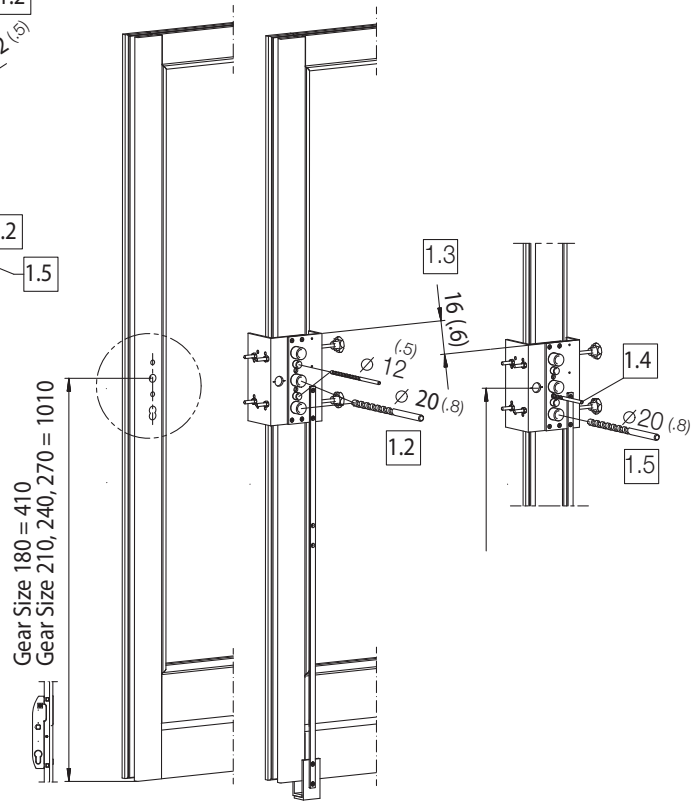
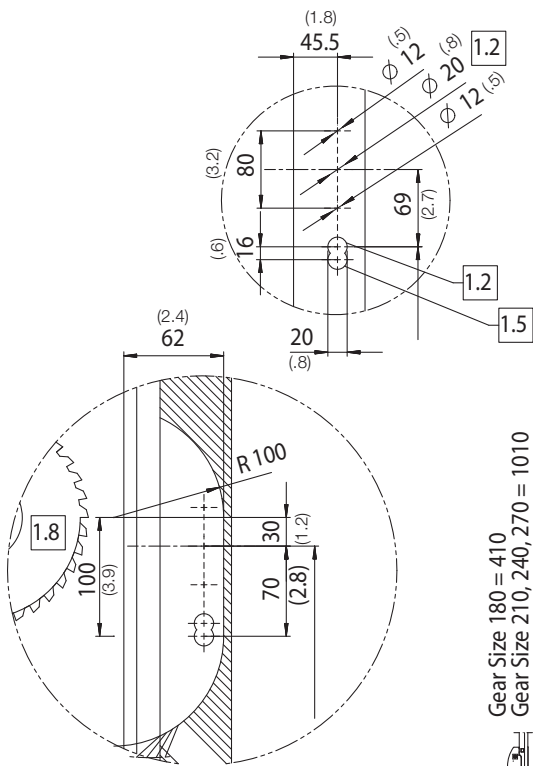

2.0

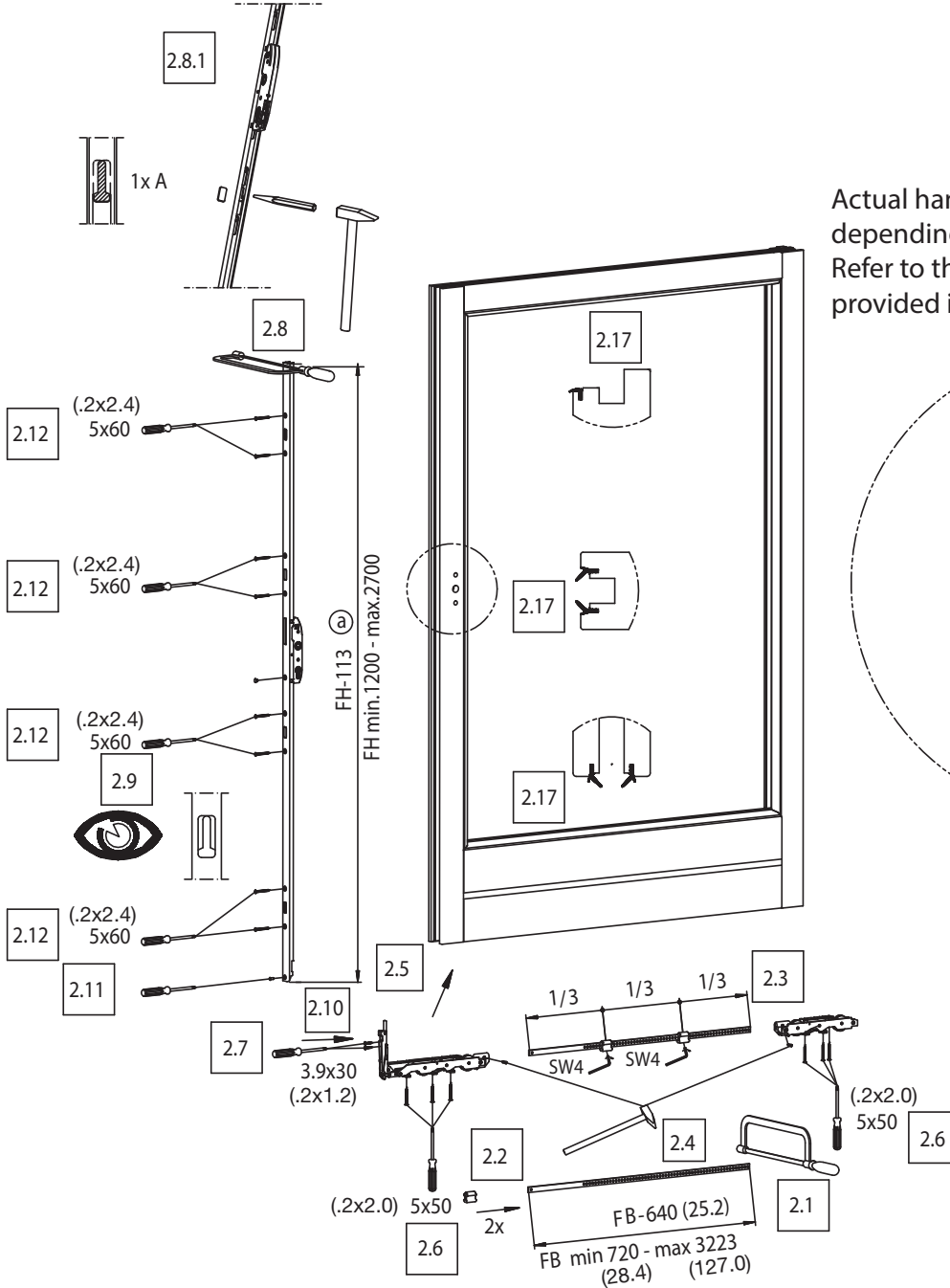

Actual handle set installation will vary depending on the style and application. Refer to the installation instructions provided in the handle set.

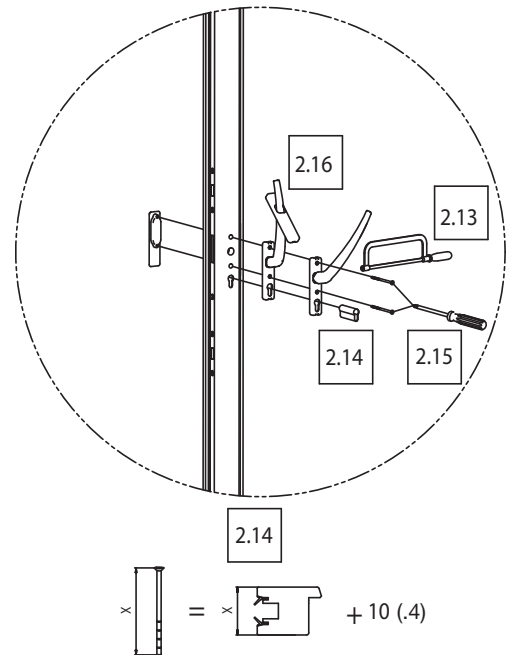

3.0

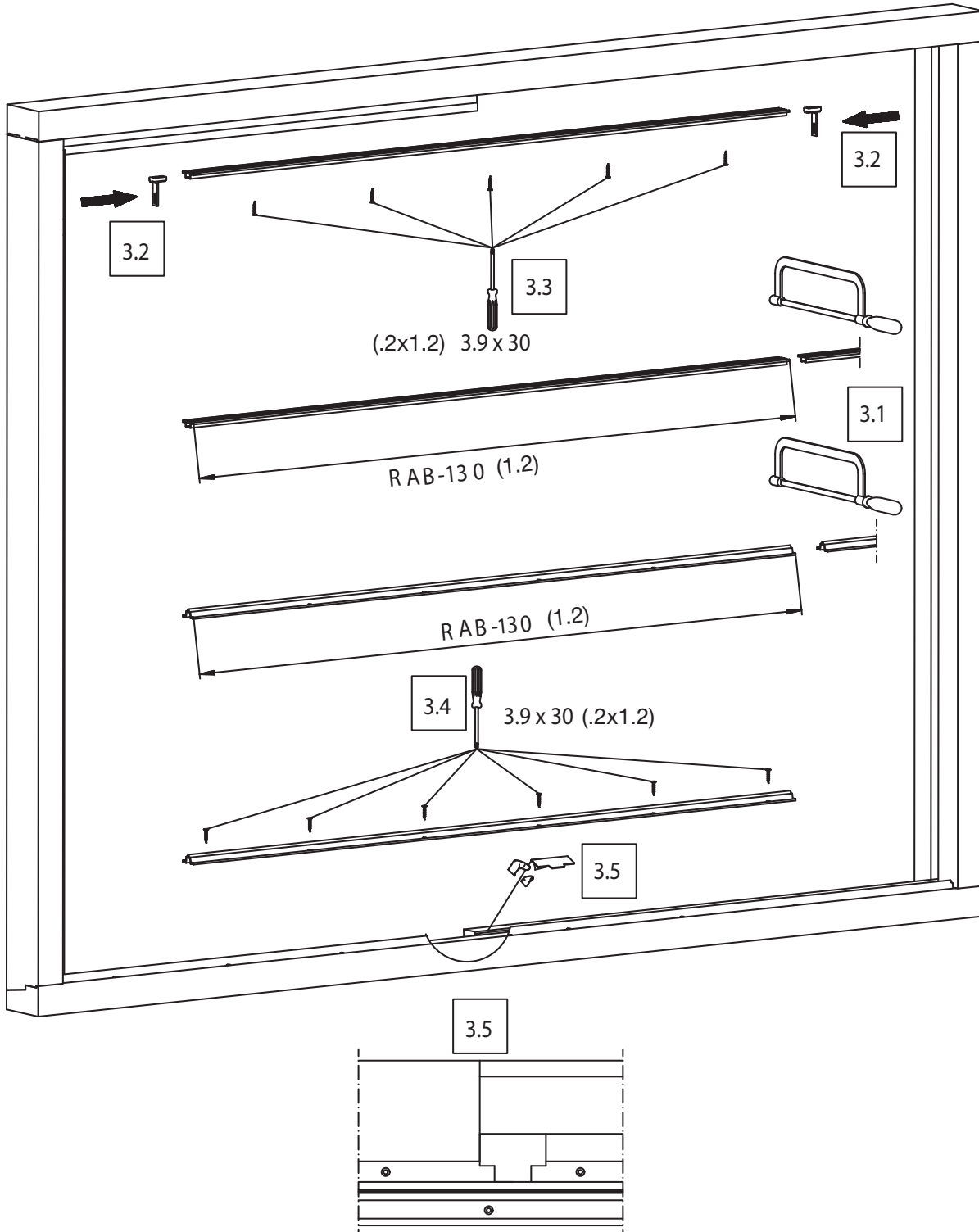

4.0

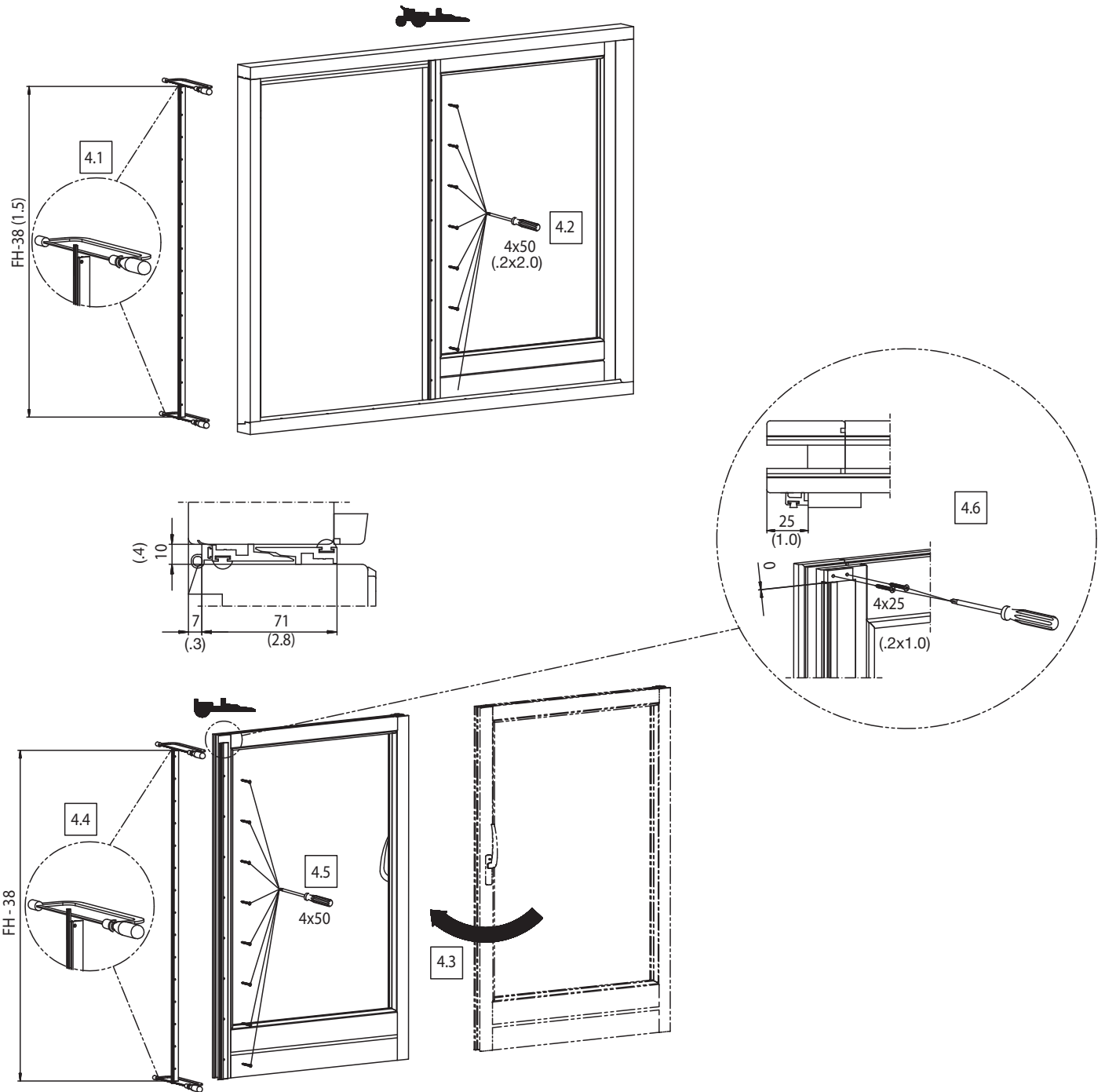

5.0

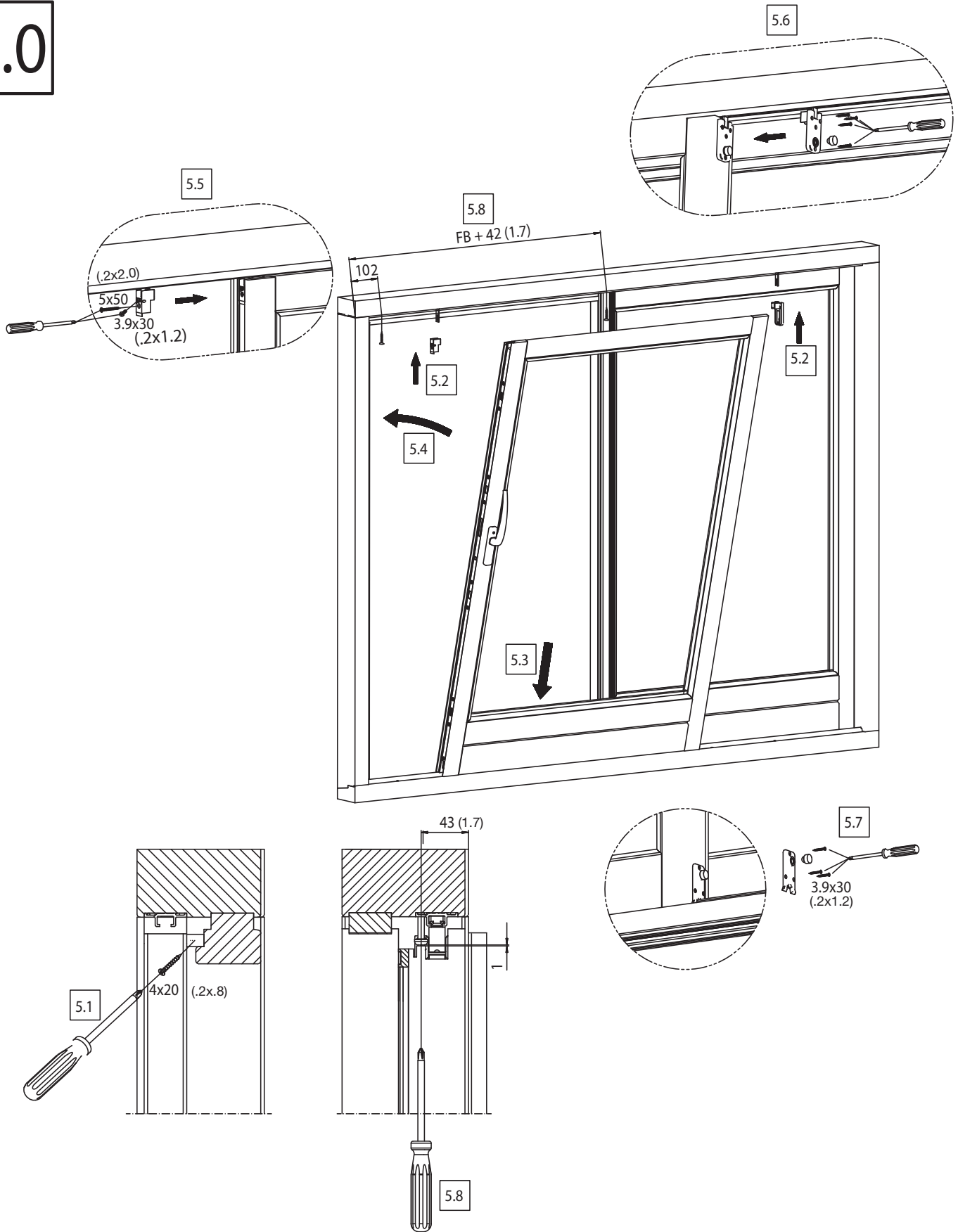

6.0

	A (mm)	A (inches)	B (mm)	B (inches)
Gear Size 180	600mm	23.6"	1000mm	39.3"
Gear Size 210	750mm	29.5"	1600mm	63.0"
Gear Size 240	750mm	29.5"	1900mm	74.8"
Gear Size 270	750mm	29.5"	2200mm	86.6"

Key for Locking Bolts,
Item # 3185194 (Page 11)

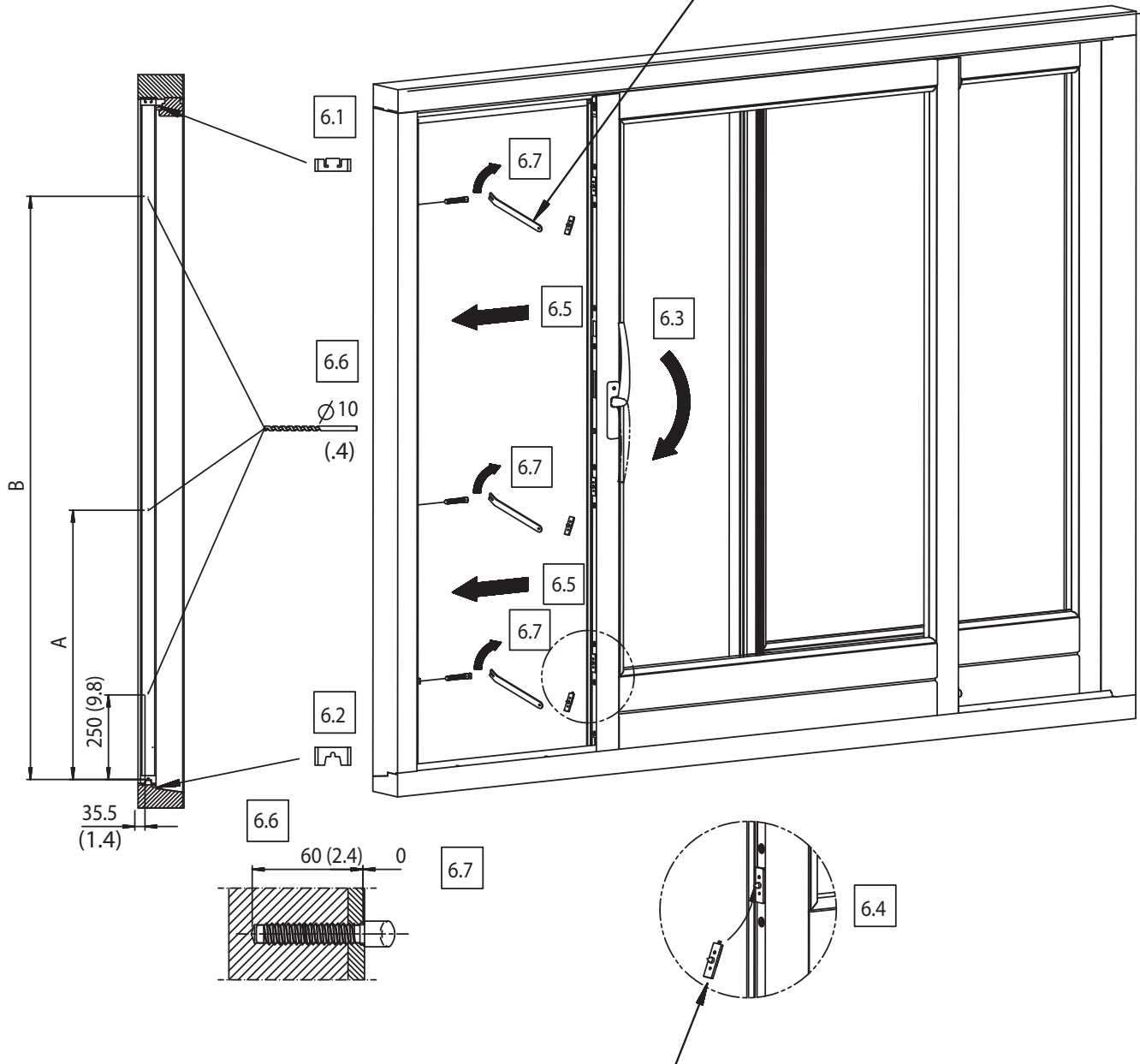

Center Punch, Item # 3185215 (Page 11)

Handle Sets

Handle / Handle

Handle / Finger Grip

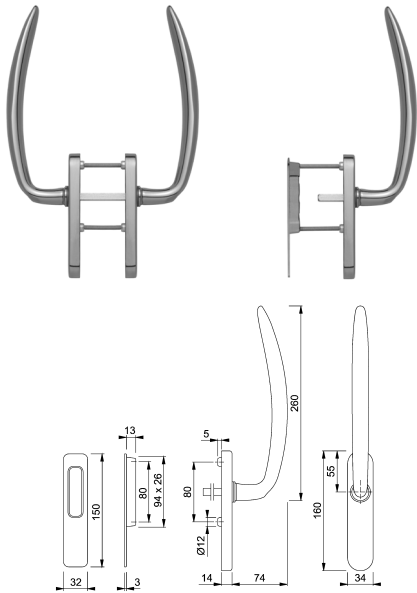

Atlanta Series HS-M0530/431N Brass Base

	Satin Nickel (F42-R)	Rustic Umber (F8709M)	Matte Black (F9714M)
Handle / Handle (Used with a Full Cylinder)	11938171	11938195	11938213
Handle / Handle (Used with a Thumbturn)	11938183	11938201	11938225
Handle / Finger Grip	11946404	11946416	11946428
Removable Handle	TBA	TBA	TBA

Cylinder sold separately - Based on thickness of door

Shaft and screws are needed based on thickness of door.

Dallas Series HS-M0643/419 Brass Base

Handle / Handle

Handle / Finger Grip

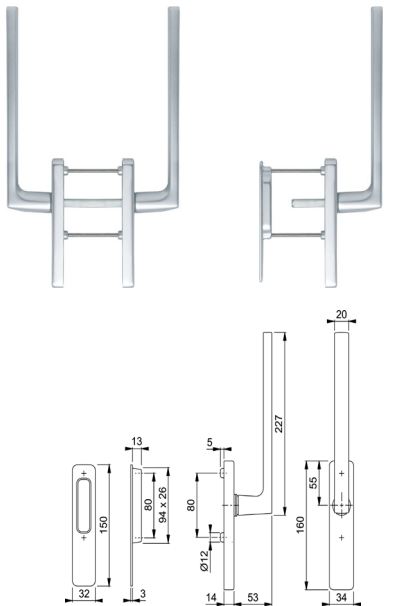

	Satin Nickel (F42-R)	Polished Brass (F77-R)
Handle / Handle (Used with a Full Cylinder)	11937385	11937634
Handle / Handle (Used with a Thumbturn)	11937567	11937646
Handle / Finger Grip	11942034	11942071
Removable Handle	TBA	TBA

	Rustic Umber (F8709M)	Matte Black (F9714M)	White (F9010)
Handle / Handle (Used with a Full Cylinder)	11937579	11937592	11937610
Handle / Handle (Used with a Thumbturn)	11937580	11937609	11937622
Handle / Finger Grip	11942046	11942058	11942083
Removable Handle	TBA	TBA	TBA

Cylinder sold separately - Based on thickness of door

Shaft and screws are needed based on thickness of door.





Indicates the item is a HOPPE **QUICK SHIP** item and is targeted for shipment within 2 weeks, for orders up to 5 openings.

Folding Series HS-4615/4610/461
Aluminum Base

Finish	Alpine Frost (32-1)	Rustic Umber (F8709)	Matte Black (F9714M)
Handle / Finger Grip	11636452	11636555	11636567

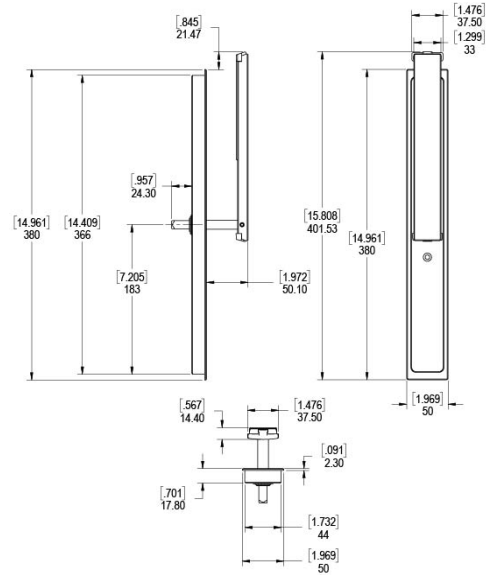
Handle Sets setup for door thickness of 2 1/2"



 Indicates the item is a HOPPE **QUICK SHIP** item and is targeted for shipment within 2 weeks, for orders up to 5 openings.

Handle Accessories

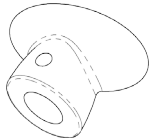

Cylinders with Thumbturns for Handle / Handle Sets must be ordered separately.

M Knob Cylinders (Cylinder size varies by door thickness)

	Polished Brass Resista® (F77-R)	Satin Nickel Resista® (F42-R)
Cylinder for a 52mm (2.04") thick door		
40.5/40.5 Full Cylinder	3746334	3746318
40.5/10 Half Cylinder	3746730	3746721
Cylinder for a 57mm (2.25") thick door		
45.5/45.5 Full Cylinder	3843732	3843716
45.5/10 Half Cylinder	3843783	3843775

	Pure White (F9010)	Rustic Umber (F8709)	Matte Black (F9714M)
Cylinder for a 52mm (2.04") thick door			
40.5/40.5 Full Cylinder	3746300	11715224	11738510
40.5/10 Half Cylinder	3746705	11715236	11738522
Cylinder for a 57mm (2.25") thick door			
45.5/45.5 Full Cylinder	3843708	11735430	
45.5/10 Half Cylinder	3843759		

Shafts

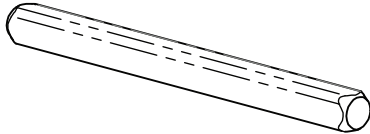

Length	Item number
10X63	3973756
10X80	7145709
10X90	7145717
10X75	7147309
10X120	7191466
10X130	7191473
10X140	7193384
10X160	7182037
10X170	3486325

Finger Pull

M423 Brass Version	Polished Brass Resista (F77-R)	Satin Nickel Resista (F42-R)	Dark Bronze Metallic (F82)	Rustic Umber (F8709M)
Finger Pull	3007603	3007611	3008016	11610305

M423 Brass Version	Matte Black (F9714M)	White (F9010)	Oil Rubbed Brass (F79)
Finger Pull	11610335	11610311	11592765

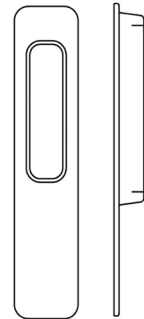

Removable Handle Rosette

	Rustic Umber (F8709)	Satin Nickel (F42)
Removable Handle Rosette	3758212	3826289

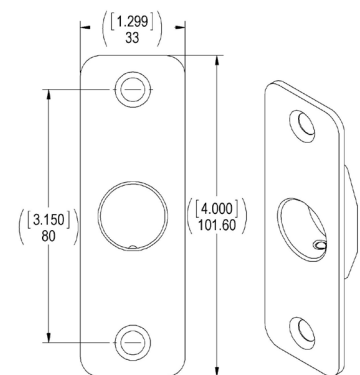



HOPPE North America, Inc.
205 E. Blackhawk Drive
Fort Atkinson, WI 53538-1268
920-563-2626
920-563-4408

1-888-485-4885
info.us@hoppe.com

