

datavideo



4K Tracking PTZ Camera
PTC-305/ PTC-305T/ PTC-305NDI

www.datavideo.com

4K Tracking PTZ Camera

Brand New 4K Auto tracking PTZ Camera

Live productions depend on high performance cameras and camera controllers. Datavideo is introducing the 4K50/60p Auto tracking PTZ camera , PTC-305 can be easily controlled via traditional RS-422 serial port, or IP remote control via DVIP (Datavideo proprietary protocol) or Sony VISCA over IP. This brand new 4K camera series supports dual streaming output for A/V market application. You can easily stream to Facebook (RTMPS), YouTube and dvCloud.

Datavideo also provides extended models such as PTC-305T 4K HDBaseT and PTC-305NDI to meet the needs of different workflows.



PTC-305T



PTC-305



PTC-305/ PTC-305T/ PTC-305NDI

- 2160p50/59.94/60 PTZ camera
- Support Auto tracking function
- 1/1.8" CMOS
- Excellent low light performance (0.5 Lux @ F1.8, AGC ON)
- 20x Optical Zoom, 16x Digital Zoom
- 4K Video outputs: HDMI 2.0, 3G-SDI, IP (H.264 & H.265)
- 2160p and 1080p (3G-SDI) Simultaneous video output
- RS-422 Serial Control
- DVIP (Datavideo Proprietary Protocol) Control
- Supports Sony VISCA via browser and VISCA over IP Protocol
- External audio input: 3.5mm audio in
- User friendly web UI via browser & app (iOS and Android)
- Dual streaming: 2160p and 720p simultaneously
- NDI | HX3 technology (PTC-305NDI)

PTC-305 SERIES



PTC-305



PTC-305T



PTC-305NDI





Quick Access to Camera's Auto tracking

You will be allowed direct access to Auto tracking via various external controllers such as the supplied RMC-1AT remote control and DVIP controllers (RMC-300A, RMC-180 MARK II and PTC View Assist). In addition to camera controllers, you can also easily enable Auto tracking on smart switchers which include KMU-200, SHOWCAST 100, etc as well as complete solution systems like ZR-1 Hybrid Video Production Solution.



SHOWCAST 100



RMC-300A



RMC-180 MARK II



PTC View Assist



TPC-700P



RMC-1AT

Custom Object Tracking

If you are filming multiple people, you can designate a person for Auto tracking. Once linked to the camera, only the designated person will be tracked, avoiding interferences such as the desks, people coming back and forth, large objects, etc.



Quick Access to Framing Options

All of the PTC-305 camera series include RMC-1AT controller. User can quickly select full-body, half-body and close up framing, making it easy to change the shooting scene and framing requirements.



Smart PTZ Speed Adaptation

The integrated PID algorithm is able to detect the movement speed of the identified object and automatically adjust the camera's corresponding pan, tilt and zoom speeds in such a way that the lens movement will be smooth, avoiding common camera lens movement problems like jerky movements or unpredicted halts.

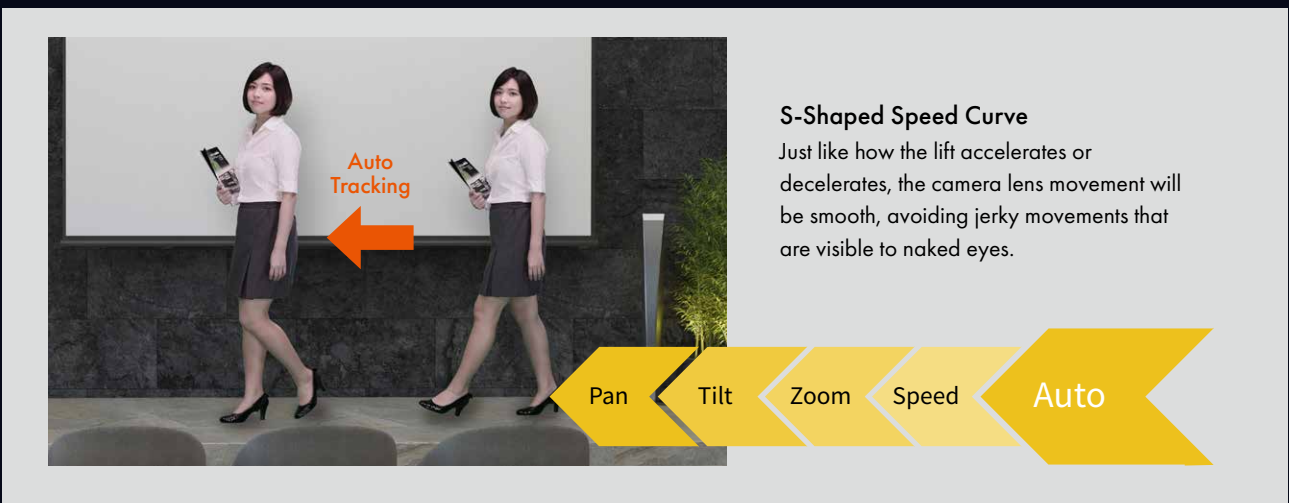

Various Control Options

Control real-time pan, tilt, and zoom camera movements with Datavideo PTZ View Assist APP, RMC-300A and RMC-180 series. With configurable preset positions supported.



SHOWCAST 100



PTZ View Assist



RMC-180 MARK II



RMC-300A

Multiple Network Protocol with Dual Stream function

Support RTSP and RTMPS protocols, easy to stream directly to two different CDN platforms and Datavideo dvCloud as well.



Multiple simultaneous video output

Supports simultaneous HDMI 2.0 and IP output up to 2160p 50/60 and also 3G-SDI output up to 1080p60/50.



streaming

4K HDMI

3G-SDI

Broadcast quality 4K HDMI / 3G-SDI PTZ camera

Resolution is up to 2160p 50/60. 20x optical zoom for PTC-305 series which you a high quality video.



PTC-305

Low Noise in low light CMOS effectively ensures high SNR of video quality.

Advanced 3D noise reduction technology is also used to further reduce the noise while ensuring image sharpness.



Supports H.264/H.265 video compression

Support compression of resolution up to 3840x2160 with frame up to 59.94, 60fps and the second channel 1280x720p with 30fps compression. AAC, MP3 and PCM audio compression also supported.



Tally Light

Green and red tally lights to show the preview and program status for broadcast applications.



RS-422, DVIP and Ethernet Camera Control

RS-422 and ethernet to use DVIP or VISCA over IP commands to integrate with larger control systems.





Simply enable Auto tracking
with your IR remote control

RMC-1AT PTZ Controller



All you need is a remote control to set and control all four cameras and save the four presets.



Menu
Press the Menu button to open the camera's OSD menu which will show you all functions of the PTC-305.

Power
Press to activate the camera or enter standby mode.

Camera Selection / Setting
Select to set or control up to four cameras.

Camera Presets
Each camera is allowed up to four presets which store the camera's current pan, tilt and zoom position, as well as settings such as iris, focus and movement speed. Presets allow quick access to settings required for specific camera shooting.

Focus
Ergonomic design to ease manual focus adjustment.

Zoom
Sets zoom speed and zooms in and out.

Micro Joystick
The joystick controls the pan and tilt directions or selects options or values while the OSD menu is opened.

Return
This returns the camera lens position to the Home position. When the OSD menu is opened, this button returns to the previous menu hierarchy level.

IP Address Reset
Press and hold to restore the default IP address.

AF Auto Focus
Press the AF button to turn on/ off auto focus function.

Store
Saves the current pan, tilt and zoom settings of the camera as well as settings such as iris, focus and movement speed to presets 1 to 4.

AT Tracking Enable
The AT button activates the auto tracking function of the PTC-305 series with one key. User can quickly select full-body, half-body and close up framing, making it easy to change the shooting scene and framing requirements.

datavideo
RMC-1AT



PTZ View Assist

Control up to four cameras with your Tablet



The camera control app is tailored for the Datavideo PTZ camera series. It can monitor the live streaming video from PTC-140, PTC-280, PTC-285, PTC-300 and PTC-305 series. The app can control up to 4 cameras simultaneously via DVIP, you can intuitively set up and recall the presets, and adjust white balance, focus, and IRIS. The app can decode the live streaming via RTSP and SRT, easily monitor the live streaming video and set up the parameters promptly in one application. Datavideo provides iOS and Android versions, you can download on Google Play and App Store for free!



Mobile phone version available soon



Camera Control

Camera

Protocol

Position



Camera control via web UI APP control

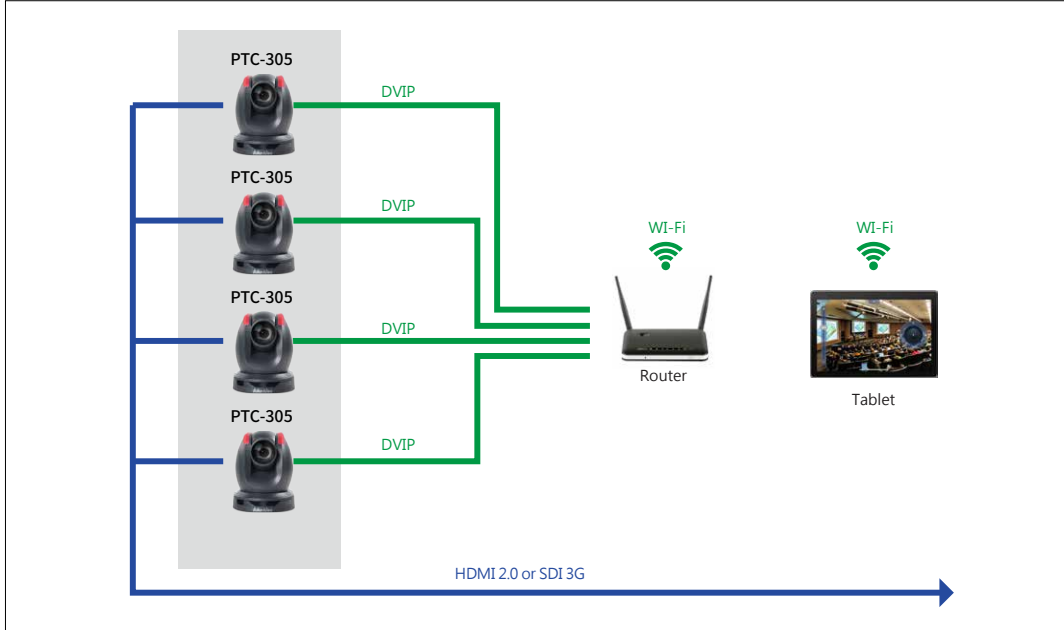

The camera control app is able to control datavideo PTZ cameras. Once you install the app on the tablet, it is easy to control the cameras in the same network!

PTC-305

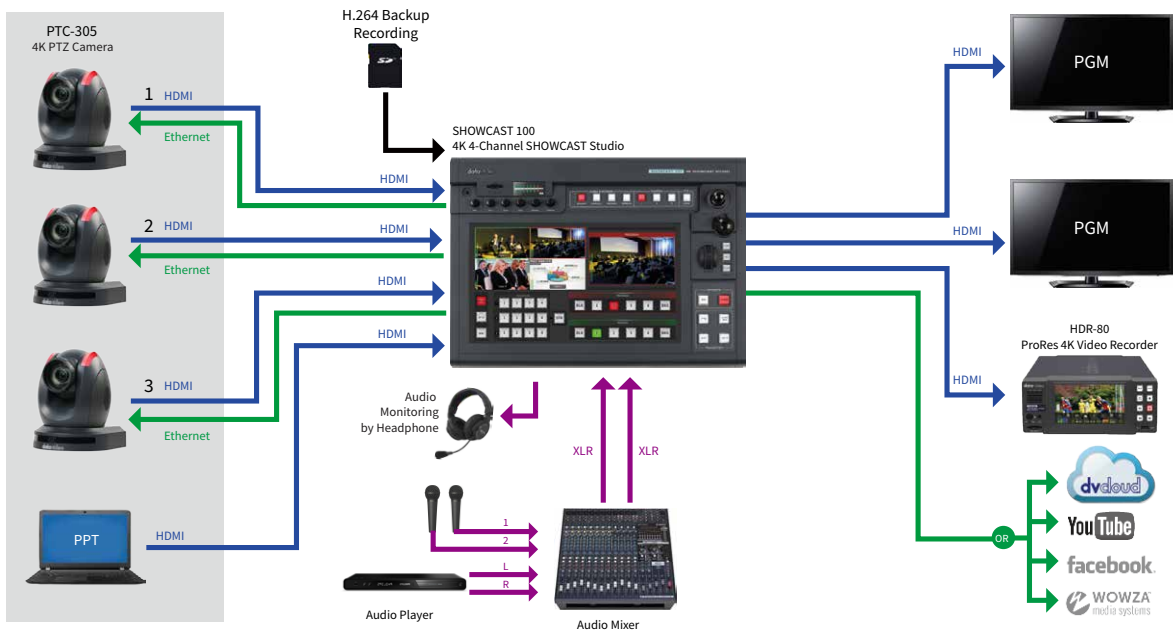

PTC-305T

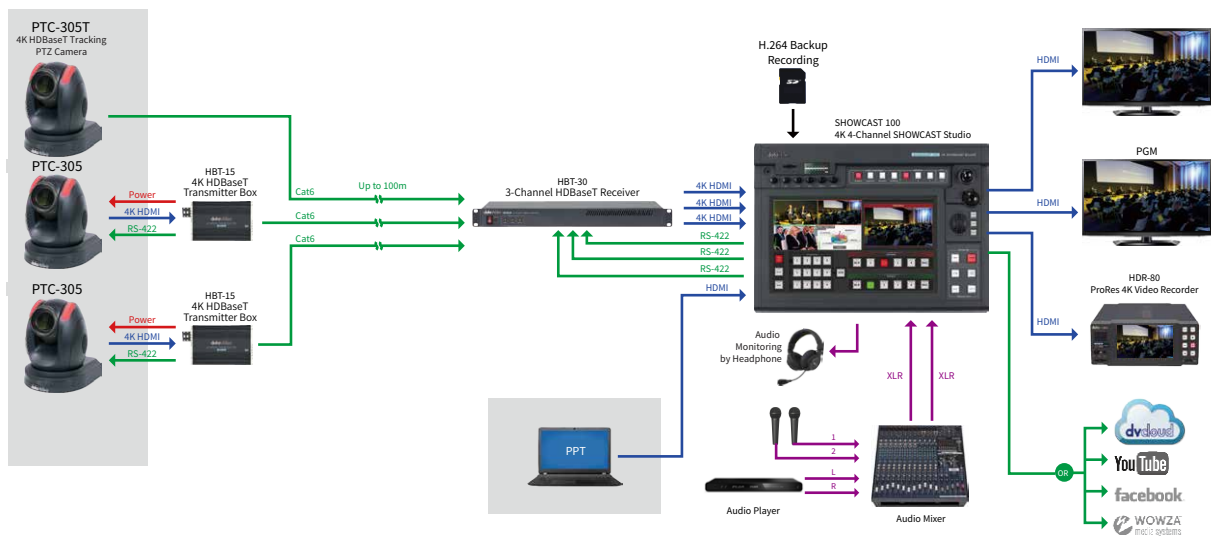

Optional accessories



VP-929
HDMI 4K Repeater

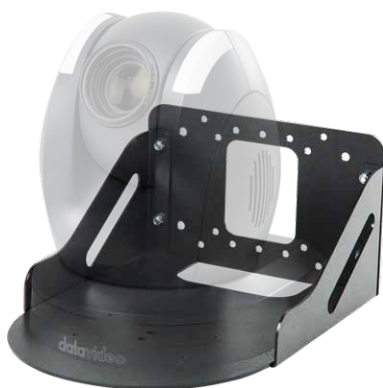

WM-1
Wall Mount



WM-1W
Wall Mount (White)

The WM-1 can be positioned upside-down or rightside-up to suit various applications. The three-piece design is sturdy, and easy to install onto any wall.

What's in the box accessories



RMC-1AT
IR remote control



Ceiling mount bracket



DC 12V Adaptor

Dimension

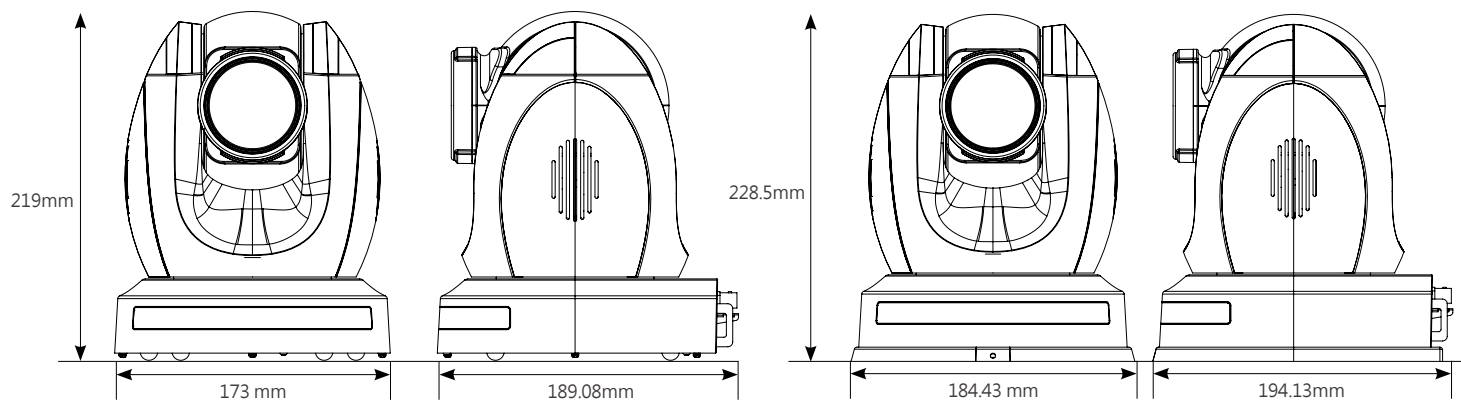

Specification



	PTC-305	PTC-305T	PTC-305NDI
Product Name	4K Tracking PTZ Camera	4K HDBaseT Tracking PTZ Camera	4K NDI Tracking PTZ Camera
Video format/Resolution	2160p60/59.94/50/30/29.97/25 1080p60/59.94/50/30/29.97/25 1080i60/59.94/50 720p60/59.94/50 *2160p60/59.94/50 YUV 4:2:2	2160p60/59.94/50/30/29.97/25 1080p60/59.94/50/30/29.97/25 1080i60/59.94/50 720p60/59.94/50 *2160p60/59.94/50 YUV 4:2:2	2160p60/59.94/50/30/29.97/25 1080p60/59.94/50/30/29.97/25 1080i60/59.94/50 720p60/59.94/50 *2160p60/59.94/50 YUV 4:2:2
Image Sensor	1/1.8" CMOS	1/1.8" CMOS	1/1.8" CMOS
Effective Pixels (approx.)	8.51Mega Pixels	8.51Mega Pixels	8.51Mega Pixels
S/N Ratio	≥ 55dB	≥ 55dB	≥ 55dB
Min. Illumination	0.5 Lux @ (F1.8, AGC ON)	0.5 Lux @ (F1.8, AGC ON)	0.5 Lux @ (F1.8, AGC ON)
Electronic Shutter	1/30s ~ 1/10000s	1/30s ~ 1/10000s	1/30s ~ 1/10000s
Zoom Ratio	20x Optical, 16x Digital Zoom	20x Optical Zoom, 16x Digital Zoom	20x Optical Zoom, 16x Digital Zoom
Gamma Control	N/A	Off / Normal	Off / Normal
Iris Control	Auto / Manual	Auto / Manual	Auto / Manual
Digital Noise Reductions	3D	3D	3D
On-Screen Display (OSD)	English/Simplified Chinese/Traditional Chinese	English/Simplified Chinese/Traditional Chinese	English/Simplified Chinese/Traditional Chinese
White Balance	Auto, Indoor, Outdoor, OnePush, Manual, VAR	Auto, Indoor, Outdoor, OnePush, Manual, VAR	Auto, Indoor, Outdoor, OnePush, Manual, VAR
AGC / Gain Control	Yes	Yes	Yes
Mirror / Flip Image	Yes	Yes	Yes
Focus Mode	Auto/Manual	Auto/Manual	Auto/Manual
Panning / Tilting Range	Pan: 300° Tilt: +130° to -15°	Pan: 300° Tilt: +130° to -15°	Pan: 300° Tilt: +130° to -15°
Panning / Tilting Speed	Pan: 0.876° /s~43° /s Tilt: 0.693° /s ~21.32° /s	Pan: 0.876° /s~43° /s Tilt: 0.693° /s ~21.32° /s	Pan: 0.876° /s~43° /s Tilt: 0.693° /s ~21.32° /s
Preset	255 Position	255 Position	255 Position
Focal Length	20x, f = 6.7mm ~125mm, F1.58 ~ F3.95	20x, f = 6.7mm ~125mm, F1.58 ~ F3.95	20x, f = 6.7mm ~125mm, F1.58 ~ F3.95
Field of View (Horizontal, Wide)	60°	60°	60°
Image Compensation	Back light compensation	Back light compensation	Back light compensation
Video Output	HDMI 2.0 x1 3G-SDI x1 10/100/1000M RJ45 (PoE) x1	HDMI 2.0 x1 3G-SDI x1 HDBaseT x 1 10/100/1000M RJ45 (PoE) x1	HDMI 2.0 x1 3G-SDI x1 10/100/1000M RJ45 (PoE) x1
Audio Input	3.5 mm x1 (mic in/line in) switch from Web UI	3.5 mm x1 (mic in/line in) switch from Web UI	3.5 mm x1 (mic in/line in) switch from Web UI
Tally LED	Yes	Yes	Yes
Lens Filter	N/A	N/A	N/A
Control Protocol	Pelco-D, Pelco-P, VISCA, VISCA over IP, DVIP	Pelco-D, Pelco-P, VISCA, VISCA over IP, DVIP	Pelco-D, Pelco-P, VISCA, VISCA over IP, NDI, DVIP
Remote Control Interface	IR Web GUI RS-422 DVIP	IR Web GUI RS-422 DVIP HDBaseT(RJ-45)/Serial control on Receiver Box: Transmit up to 100m	IR Web GUI RS-422 DVIP NDI
Video Compression Format	H.264/H.265/MJPEG	H.264/H.265/MJPEG	H.264/H.265/MJPEG
Audio Compression Format	AAC	AAC	AAC
Audio Bitrate	96Kbps, 128Kbps	96Kbps, 128Kbps	96Kbps, 128Kbps
Streaming Protocols	RTSP, RTMP(S), Onvif, Multicast, SRT	RTSP, RTMP(S), Onvif, Multicast, SRT	RTSP, RTMP(S), Onvif, Multicast, SRT, NDI Hx3 (1080p)
First Stream Supported Resolution	3840x2160 1920x1080 1280x720 1024x576 960x540 640x480 640x360	3840x2160 1920x1080 1280x720 1024x576 960x540 640x480 640x360	3840x2160 1920x1080 1280x720 1024x576 960x540 640x480 640x360
Second Stream Supported Resolution	720x480 640x360 480x270 320x240	720x480 640x360 480x270 320x240	720x480 640x360 480x270 320x240
Video Bitrate	32Kbps ~ 50Mbps (Single Stream)	32Kbps ~ 50Mbps (Single Stream)	32Kbps ~ 50Mbps (Single Stream)
Video Bitrate Mode	VBR, CBR	VBR, CBR	VBR, CBR
Encoding Frame rate	50Hz: 1-50fps , 60Hz: 1-60fps	50Hz: 1-50fps , 60Hz: 1-60fps	50Hz: 1-50fps , 60Hz: 1-60fps
POE	IEEE 802.3AT.	IEEE 802.3AT.	IEEE 802.3AT.
F/W Update	Via Web UI or USB 2.0	Via Web UI or USB 2.0	Via Web UI or USB 2.0
IR Control	Yes	Yes	Yes
Camera Control Unit	RMC-180 series/RMC-300 series/ PTZ View Assist APP	HS-1600T series/RMC-180 series/RMC-300 series/ PTZ View Assist APP	RMC-180 series/RMC-300 series/ PTZ View Assist APP
Tripod Mount	1/4-20 UNC	1/4-20 UNC	1/4-20 UNC
Optional Accessories	WM-1/ WM-10/ WM-11	WM-1/ WM-10/ WM-11	WM-1/ WM-10/ WM-11
Color	Dark Blue/White	Dark Blue/White	Dark Blue/White
Dimension (LxWxH)	173 (W) x 219 (H) x 189.08 (D)	173 (W) x 219 (H) x 189.08 (D)	173 (W) x 219 (H) x 189.08 (D)
Weight	2.6 kg	2.6 kg	2.6 kg
Operating Temp. Range	0~40 ° C	0~40 ° C	0~40 ° C
Power	DC 12V 21W	DC 12V 22W	DC 12V 22W



@DatavideoUSA @DatavideoAsia
@DatavideoEMEA @DatavideoIndia2016
@DatavideoTaiwan @Datavideojapan



@Datavideo
@Datavideo_EMEA
@Datavideo_Taiwan



@DatavideoUSA
@DVTWIDVCN



@DatavideoUSA
@DatavideoEurope

Disclaimers of Product and Services

This brochure is intended as a guide only. We reserve the right to change specifications and availability without prior notice. While we strive for complete accuracy, be aware that it may contain errors and omissions. Prior to purchase, please check with your local Datavideo office or authorised distributor.

Ver.20230808