

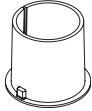









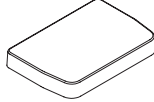
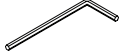
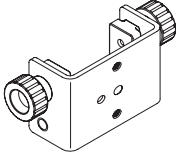
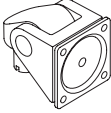

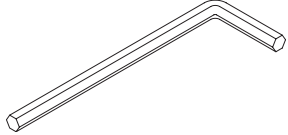
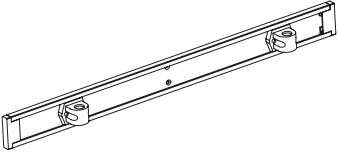
CAUTION

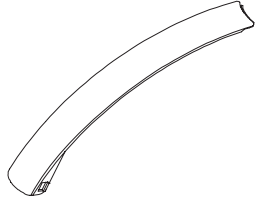
Mechanism can rise quickly with no equipment in place. User equipment must be properly installed, prior to height adjustment. Failure to do so may result in personal injury and/or property damage.

Dual Ella

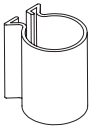
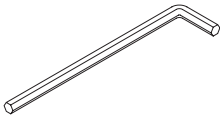
Parts List

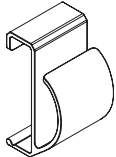
<p>A Ella Mount Bushing 1x 114022</p> 	<p>F 75/100mm VESA Adapter 2x 105587</p> 	<p>K Column Cap 1x 113984</p> 	<p>P 1/8" Allen Wrench 1x 701312</p> 
<p>B Ella Tilter Channel 1x 414249</p> 	<p>G Standard Monitor Tilter 2x 405397</p> 	<p>L Forearm Cover 1x 114007</p> 	<p>Q 8mm Allen Wrench 1x 714317</p> 
<p>C Horizontal Beam 1x 414818</p> 	<p>H M4 x 12mm PhPHS (4-pack) 2x 702096</p> 	<p>M Lower Arm Cover 1x 114016</p> 	<p>R 3mm Allen Wrench 1x 701313</p> 
<p>D M5 x 10mm Screws 2x 713966</p> 	<p>I Dog Washer 2x 111230-603</p> 	<p>N Cable Clip 2x 113679</p> 	<p>S 7/32" Allen Wrench 1x 701127</p> 
<p>E 10-32 x 3/8" PhPHS (4-pack) 2x 702281</p> 	<p>J 10-32 x 1/2" FHSCS 2x 711240</p> 	<p>O Cable Clip for Horizontal Beam 2x 112082</p> 	

1

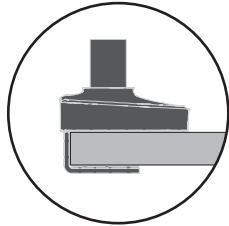

Desk thickness
up to 1.7" (4.3 cm)

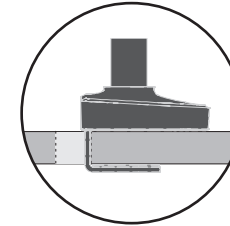

Desk thickness
up to 1.7" (4.3 cm)

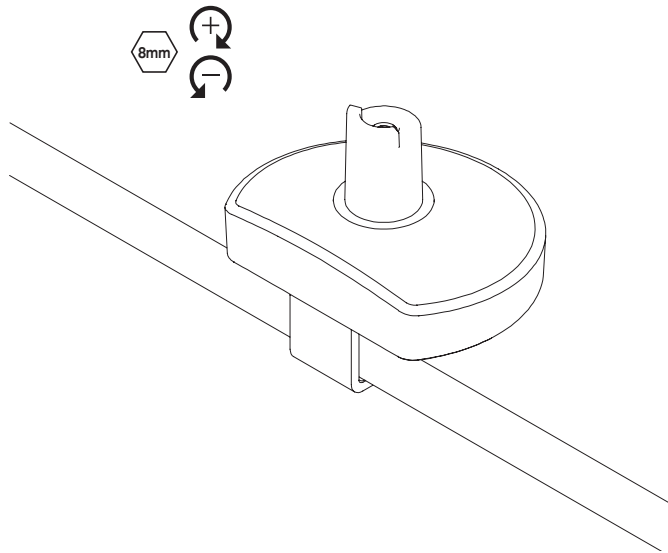

OR

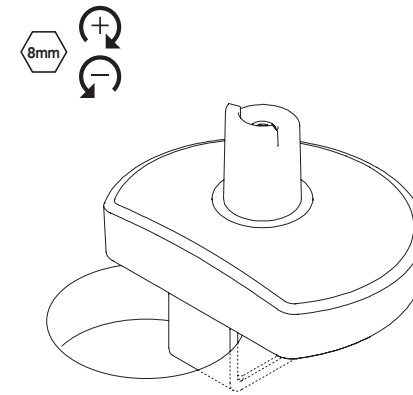

2

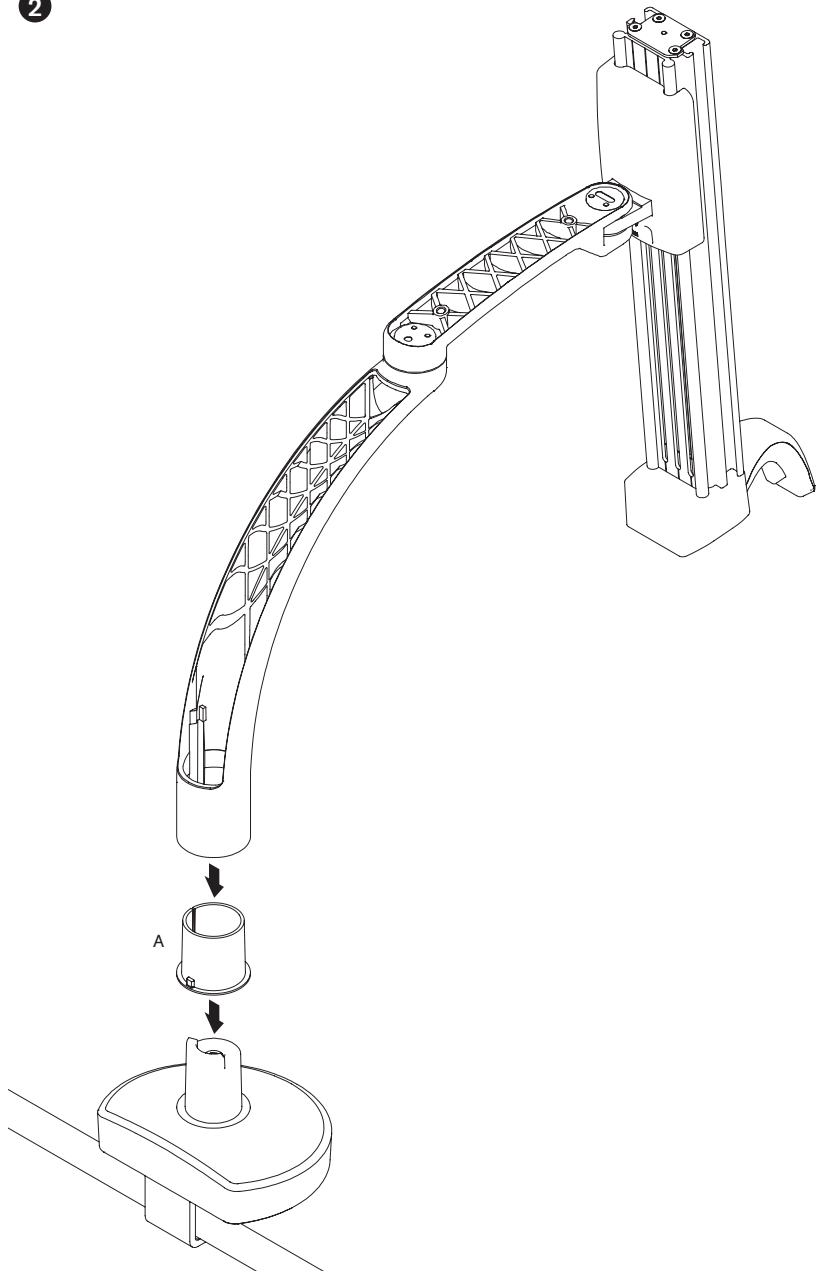

3

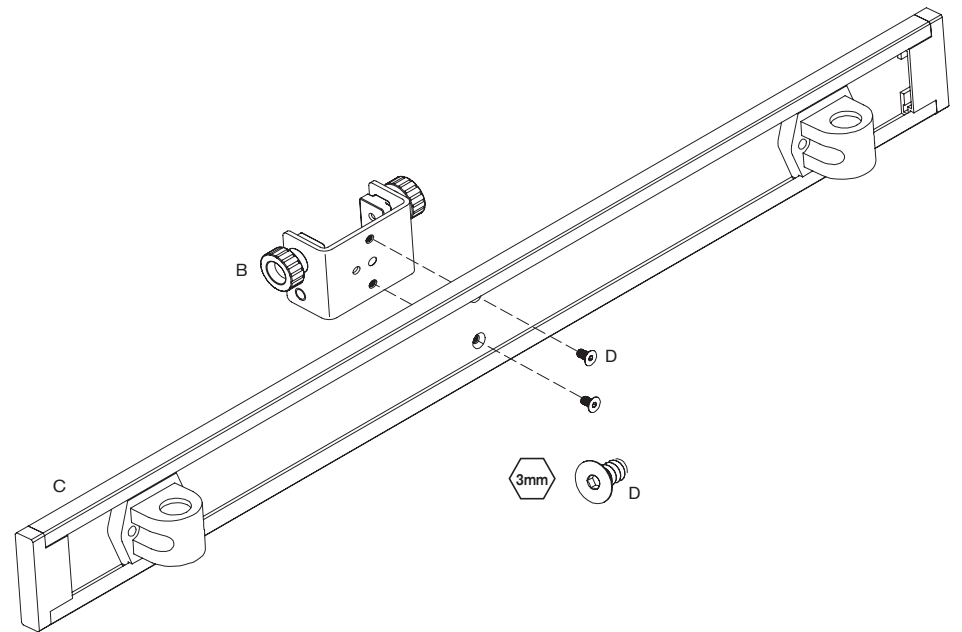

4

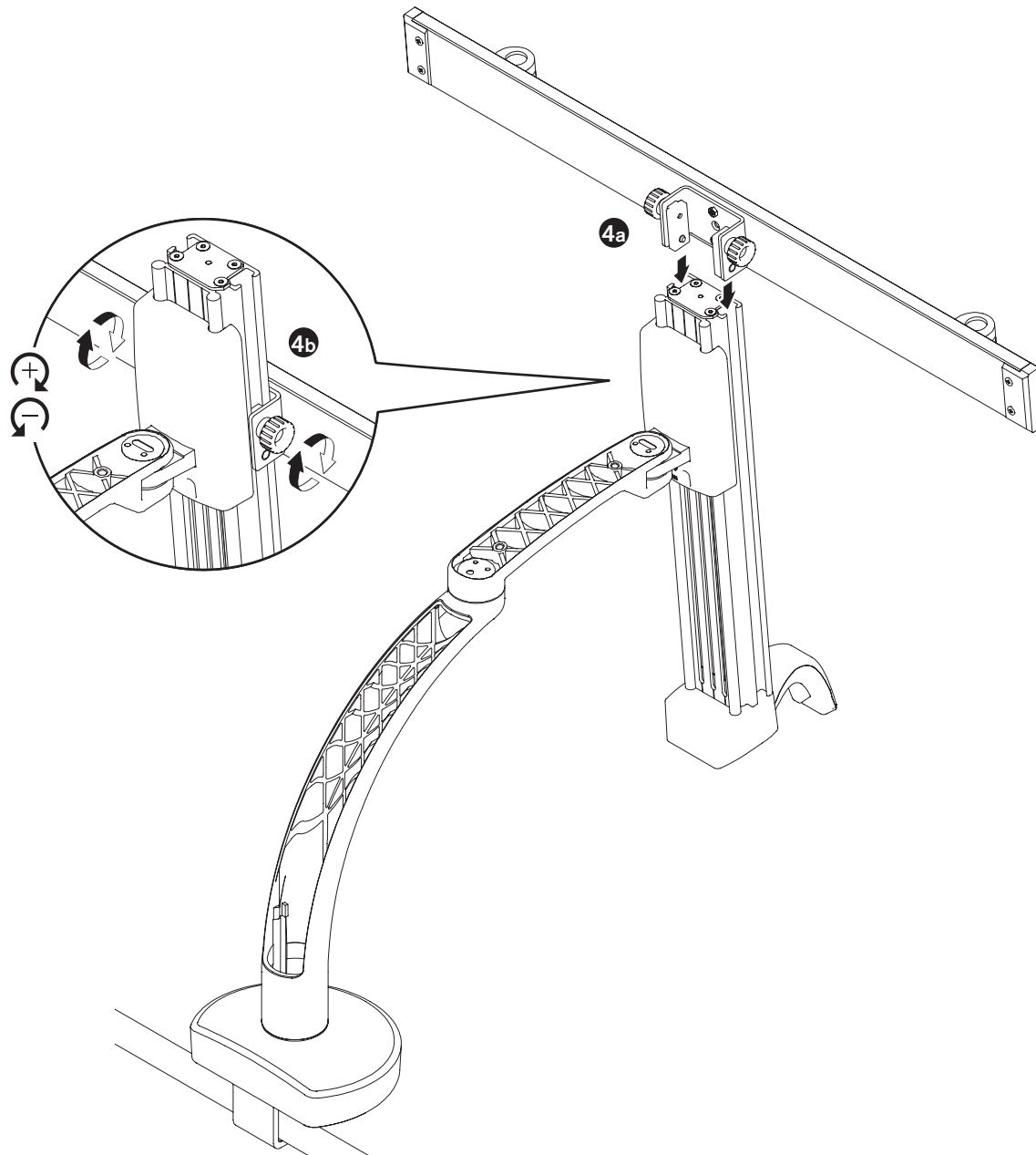

5

2x

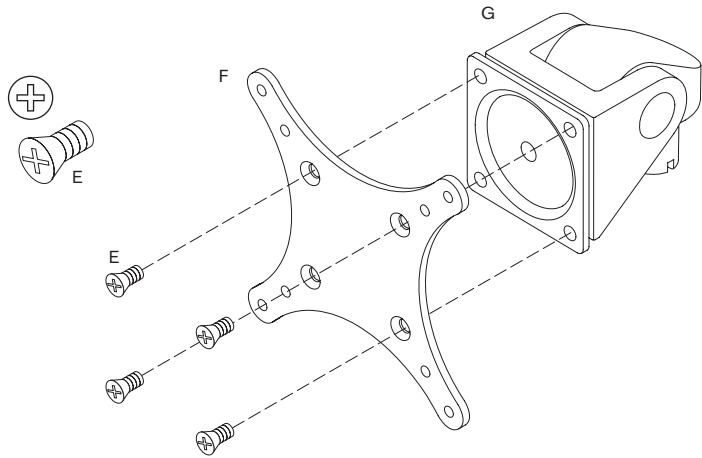

6

2x

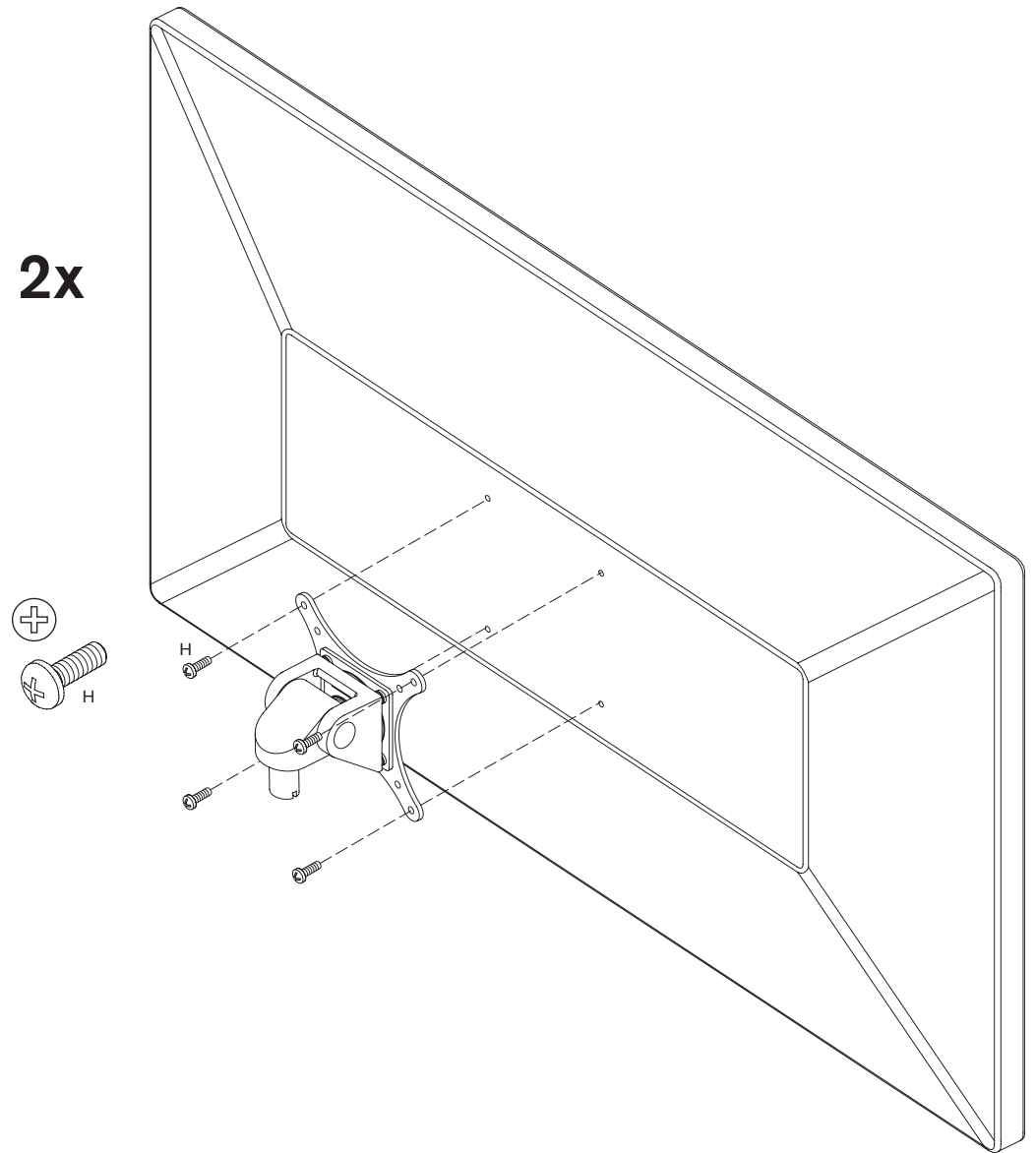

7

Monitor Weight Settings

Vertical beam must be fully raised as shown in 7a before the screw configuration is adjusted.

0 - 15 lbs
(0 - 6.8 kg)

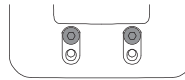

15 - 22 lbs
(6.8 - 9.9 kg)

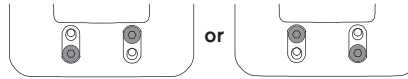

22 - 30 lbs
(9.9 - 13.6 kg)

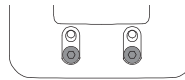

7a

7b

3mm



Height Adjust

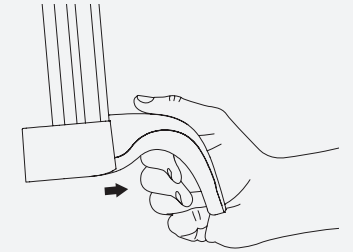

Press button and hold.

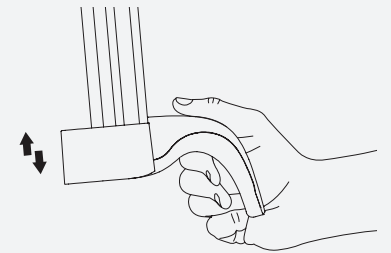

Lift up/down.

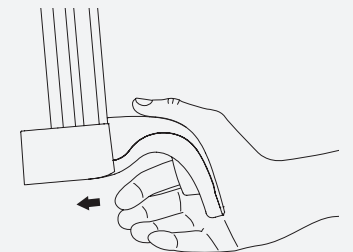

Release to lock in place.

8

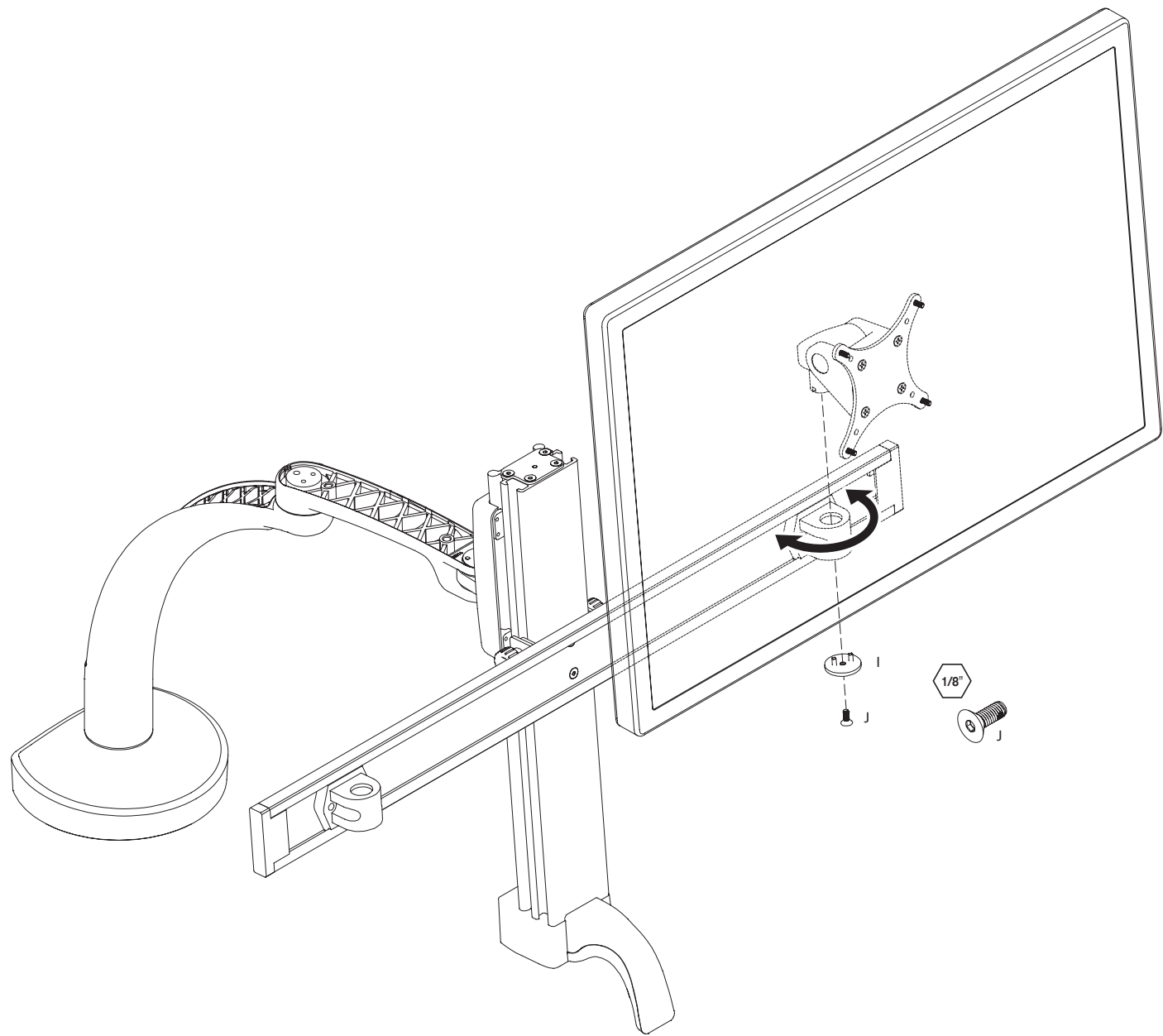

2x

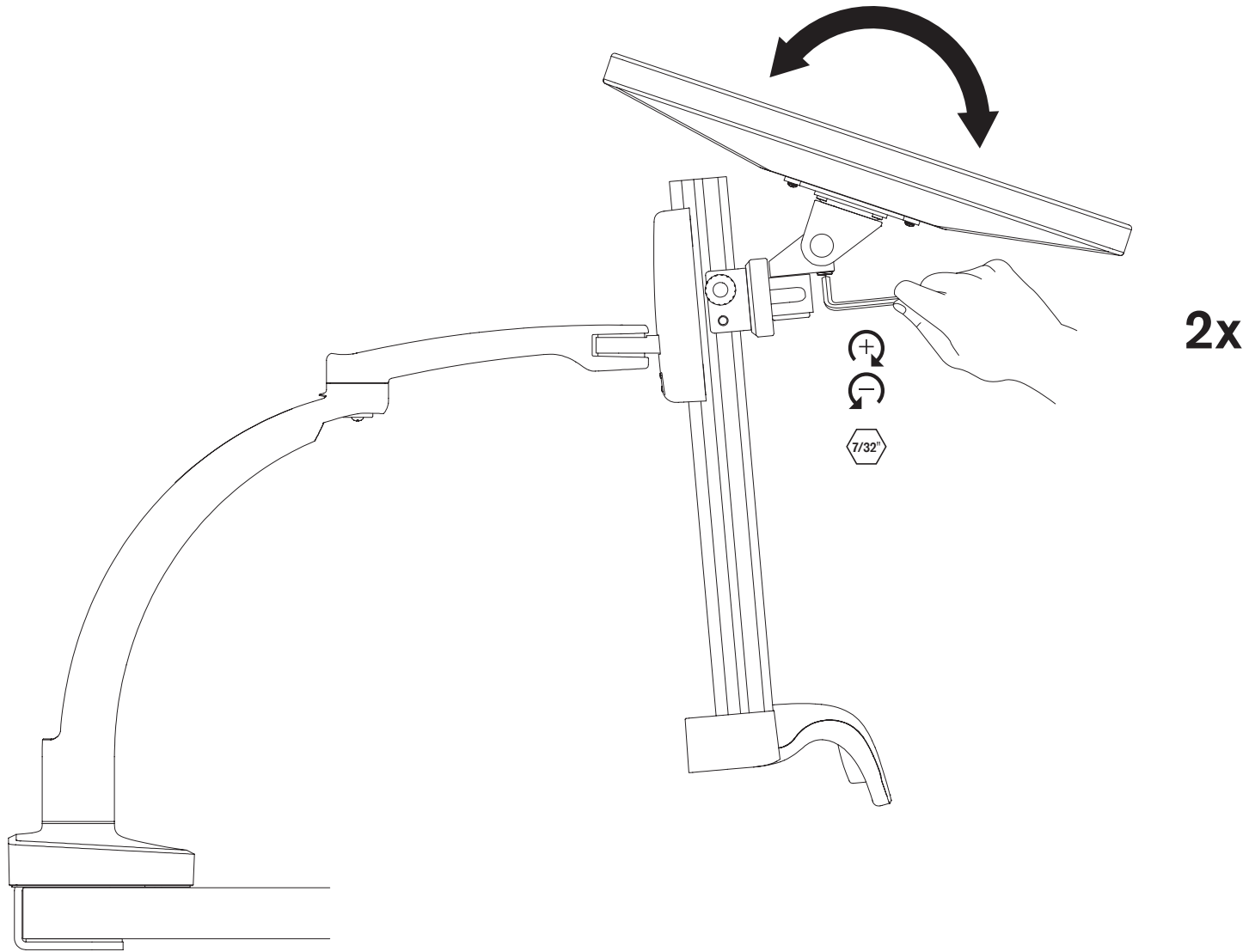

10

