

Broadband Thunderbird

Model TH-5MK2 Instruction Manual

hy-gain[®]

**308 Industrial Park Road
Starkville, MS 39759 USA
PH: 662-323-9538 FAX: 662-323-6551**

Please record the following information for you records:

Date of Purchase: _____

Purchaased From: _____

Price Paid: _____

Please retain your copy of the Bill-of-Sale for warranty claims

TABLE OF CONTENTS

	Page
CHAPTER 1	
General Description	1
Specifications	1
CHAPTER 2	
Preparation for Assembly	3
CHAPTER 3	
Assembly of the Boom-to-Mast Bracket and Boom	5
Assembly of the Element-to-Boom Brackets on the Boom	6
Installation of Tubing Clamps	7
Element Assembly	9
Front Driven Element	9
Rear Driven Element	9
10 Meter Reflector Element	10
15-20 Meter Reflector Element	10
10-15-20 Meter Director Element	12
Final Element Assembly	12
Phasing Line Assembly	13
Beta Match Assembly	14
Feedpoint Assembly	15
Final Assembly Checklist	17
CHAPTER 4	
Installation	19
Installation On a Crank-Up Tower	19
Attaching the Antenna to the Mast	19
Other Types of Towers	19
Lightning Protection	20
Attachment of Feedline	20
VSWR Curves	20
CHAPTER 5	
Operation	23
CHAPTER 6	
Troubleshooting	25
CHAPTER 7	
Service Information	27
CHAPTER 8	
Parts List	29

LIST OF ILLUSTRATIONS

Figure		Page
1	Boom-to-Mast Bracket	5
2	Assembly of Boom	6
3	Element-to-Boom Bracket	7
4	Tubing Clamps	8
5	Trap Detail	10
	Detail A – Trap Detail – Measuring Point	10
6	Element Assembly and Antenna Dimensions	11
7	Rope Dampener	12
8	Overall View of Beta Match and Phasing Tubes	13
9	Beta Match Assembly	14
10	Pigtail to Rear Driven Element	15
11	Pigtail to Balun Connection and Front Driven Element	16

CHAPTER 1

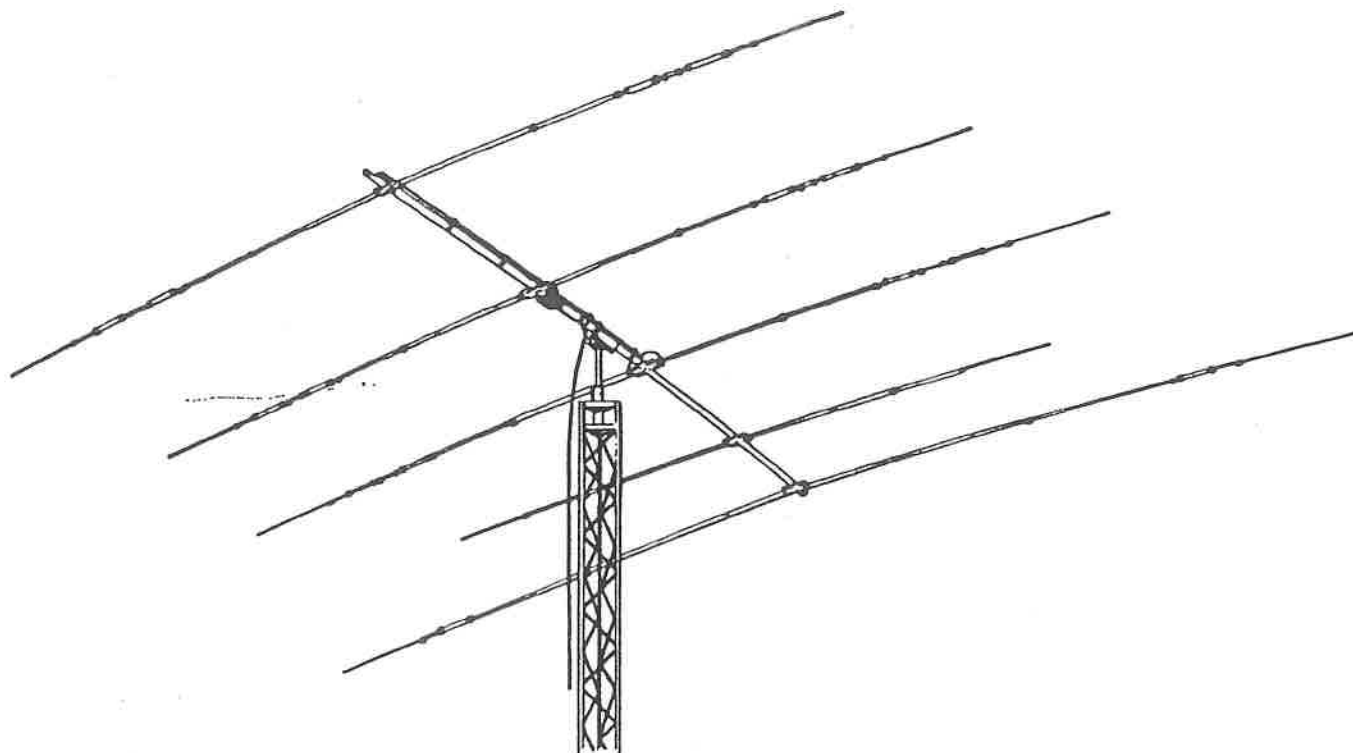

General Description

The Hy-Gain TH5/MK2 is a 5 element, three band beam antenna designed for broadband, high performance operation on the Amateur 10, 15 and 20 meter bands. Broadbanding is accomplished through the use of two fully trapped driven elements. Stainless steel hardware and clamps are used on all electrical connections. Hy-Gain's 50 ohm BN-86 balun and preformed feed straps are supplied. The antenna is designed to fit masts from 1.9" to 2.5" in diameter and can be rotated with Hy-Gain's CD-45II, Ham IV or T2X rotators.

Specifications

	<u>Electrical</u>		
Frequencies of Operation:	20m	15m	10m
Under 2:1 VSWR (MHz).....	14.0-14.35	21.0-21.45	28.0-29.4
Under 1.5:1 VSWR (MHz).....	14.09-14.32	21.11-21.45	28.25-29.15
Front-to-Back Ratio (dB).....	19 +/-5	22 +/-5	19 +/-5
Average 1/2-Power Beamwidth (deg)....	67	66	66
Maximum Gain (dBi)	7.8	8.0	9.0
Maximum Power	_____	Maximum Legal	_____
Lightning Protection	_____	DC Ground	_____

Mechanical

Boom Length	19 feet (5.8 m)
Boom Diameter	2 inches (5.1 cm)
Longest Element	31' 6" (9.6 m)
Longest Driven Element (one-half total length)	20m - .183 wavelength
	15m - .206 wavelength
	10m - .227 wavelength

**Specifications
(Cont.)**

Mechanical (Cont.)

Turning Radius	18'5" (5.6m)
Accepts Mast	1.9" to 2.5" O.D. (50 mm to 63.5 mm)
Net Weight	57 lbs. (25.8 kg)
Maximum Wind Survival	100 mph (161 kmph)
Effective Wind Area	7.4 sq. ft. (0.68 m ²)
Effective Moment*	1050 ft. lbs (144 kg-m)
Wind Load at 80 mph	190 lbs. (86 kg)
Element Tubing Clamps.....	All stainless steel
Hardware.....	Stainless steel, except for boom-to-mast bolts
Suitable Rotators	Hy-Gain CD-45II, Ham IV or T ² X
•Projected Area (elements)	10.1 sq. ft. (.94 sq. m.)
(boom)	3.2 sq. ft. (.30 sq. m.)

*Effective moment is defined as the product of the antenna weight and turning radius.

•Projected Area is the actual (flat) projected area of either the elements or boom (highest value) **without any shape factor** included. This area may be used with EIA/TIA-222-D and later versions and with the UBC formulas to determine tower and mast loading. On HF beams, the element area is usually higher. On VHF/UHF beams, the boom area is usually higher. When stacking HF and VHF beams, use the element area of all beams at their attachment points to determine loading at zero degrees to the boom axis.

CHAPTER 2

Preparation for Assembly

FOR OUR OVERSEAS CUSTOMERS: The United States uses English units of measurement. Please see Parts List in back of this manual for assistance in identifying the hardware and components supplied with this product.

Choose a large, clear area to assemble the TH5/MK2. The area must be at least 19 ft. x 31 ft. 6 in. (5.8 m x 9.6 m). You may wish to use sawhorses or chairs to support the boom during assembly. A concrete driveway is an excellent area for assembly. If you assemble this antenna over a grassy area, precautions should be taken so that hardware is not accidentally lost during assembly.

TOOLS: The following tools are required for easy assembly of the TH5/MK2:

Qty	Type Tool
1	Tape Measure, 12 foot
2	Adjustable Wrench, 8 inch
1	Nut Driver, 7/16 inch
1	Nut Driver, 3/8 inch
1	Nut Driver, 5/16 inch

When unpacking your antenna, check inside of all tubing for parts (traps, smaller tubing, etc.). To conserve space, these smaller articles are sometimes put inside larger pieces. Check all parts against the Parts List to make sure no parts are missing. The hardware supplied with this antenna is bagged by thread size for your convenience.

All tubing supplied with the TH5/MK2 telescopes together. Make all measurements to the given dimensions, plus or minus, no more than an 1/8 inch.

The assembly of this antenna will be easier if you read this manual completely through at least three (3) times before beginning assembly. Allow at least 6 hours for assembly. Double and triple check ALL dimensions after assembly.

NOTE: An extra Figure 6 has been inserted in this manual for use when assembling the antenna.

The position of the elements onto the boom begins at the center of the antenna and progresses outward. Follow the instructions as outlined on page 5 and refer to Figure 6 for assistance.

CHAPTER 3

Assembly of the Boom-to-Mast Brackets and Boom

Select the boom-to-bracket clamp parts (Item Nos. 66 & 67). Loosely assemble them on the boom ends (Item No. 65), as shown in Figure 1. Line up the holes on both brackets and both boom ends. Secure the two brackets together with four (4) 1/4"-20 X 3/4" bolts, lockwashers, and nuts. Secure the brackets to the two boom ends using the 5/16"-18 x 2 3/4" bolts, lockwashers, and nuts. Tighten these six (6) bolts securely. The use of heavy motor oil on stainless steel threads will prevent galling of threads.

Assemble the two cast aluminum brackets (Item No. 59) on the mast at the desired height above your tower. Secure the two brackets together using the two (2) 5/16"-18 x 4" bolts, lockwashers, and nuts. You may wish to drill a hole through your mast so that the remaining 5/16"-18 x 4" bolt may be inserted through the cast brackets and the mast and tightened. This bolt will prevent the antenna from twisting on the mast in high winds. See Figure 1. The four (4) 5 inch bolts will be installed when the antenna is installed on the mast.

Slip the two remaining boom sections (Item No. 57) over the two swaged ends of the assembled boom and secure using (2 each) 1/4"-20 x 2 1/2" bolts, lockwashers, and nuts as shown in Figure 2.

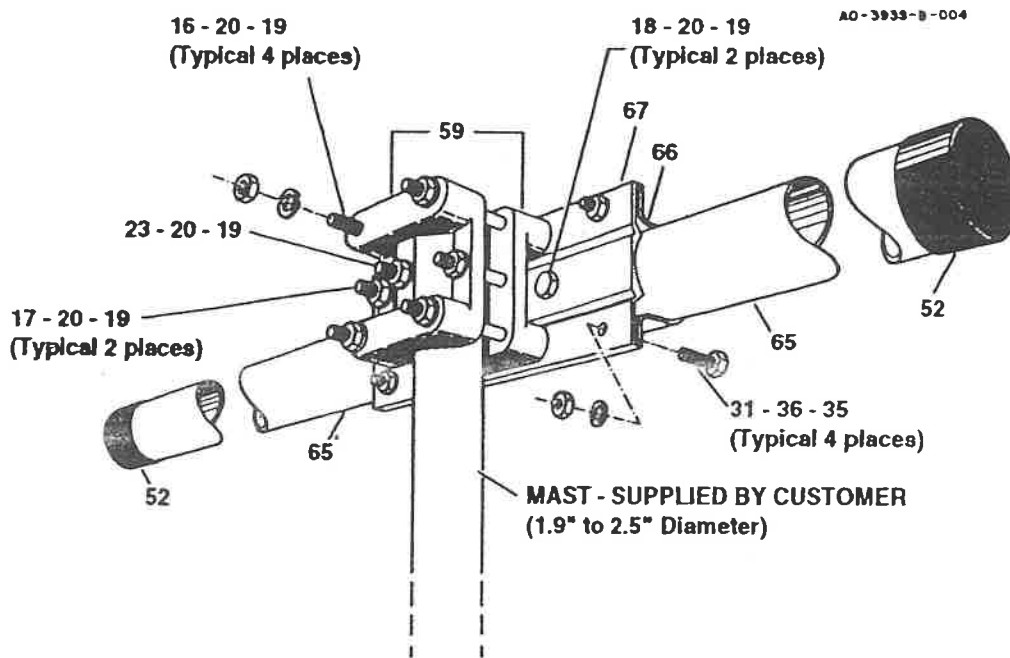

Item No.	Description	Item No.	Description
16	Bolt, hex head, 5/16"-18 x 5"	35	Nut, hex, 1/4"-20
17	Bolt, hex head, 5/16"-18 x 3"	36	Lockwasher, internal, 1/4"
18	Bolt, hex head, 5/16"-18 x 2 3/4"	52	Caplug, 2"
19	Nut, hex, 5/16"-18	59	Mast Bracket, cast aluminum
20	Lockwasher, split, 5/16"	65	Tube, Boom, swaged, 2" x 41"
23	Bolt, hex head, 5/16"	66	Clamp, Boom-to-Bracket
31	Bolt, hex head, 1/4"-20 X 3/4"	67	Bracket, Casting-to-Boom

Figure 1
Boom-to-Mast Bracket

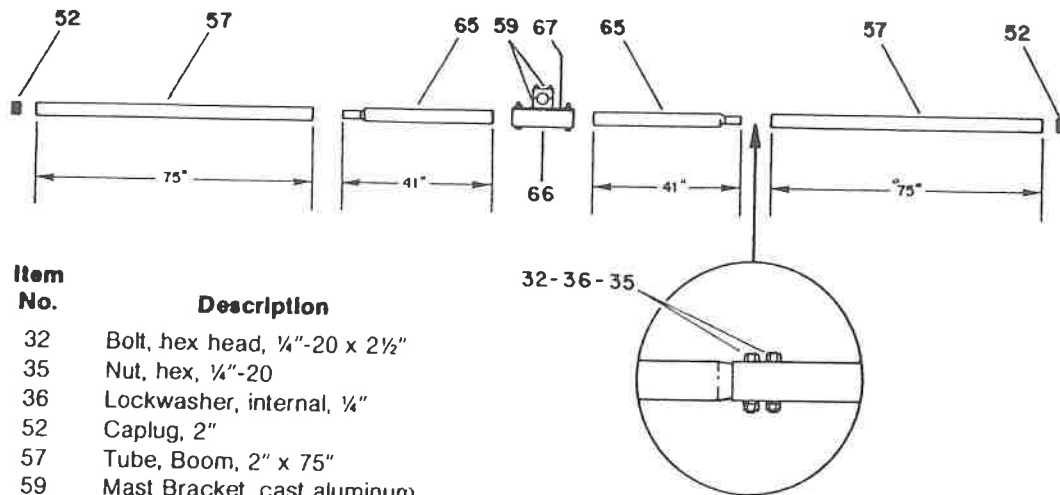

Item No.	Description
32	Bolt, hex head, ¼"-20 x 2½"
35	Nut, hex, ¼"-20
36	Lockwasher, internal, ¼"
52	Caplug, 2"
57	Tube, Boom, 2" x 75"
59	Mast Bracket, cast aluminum
65	Tube, Boom, swaged, 2" x 41"
66	Clamp, Boom-to-Bracket
67	Bracket, Casting-to-Boom

Figure 2
Assembly of Boom

Assembly of the Element-to-Boom Brackets on the Boom

Front Driven Element —

Select one pair of the largest element-to-boom brackets (Item No. 62). These are marked with a number 14. Assemble the brackets on the boom 35 inches to the left of the mast bracket (center-to-center). The curved side of the mast bracket must be facing you. Refer to Figure 3 for identification of hardware and Figure 6 for clarification. DO NOT tighten the bolts at this time.

Rear Driven Element —

Select another pair of the largest element-to-boom brackets (Item No. 62). Assemble these brackets on the boom 20 inches to the right of the center of the mast bracket. Refer to Figure 3. DO NOT tighten the bolts at this time.

10 Meter Reflector —

Select a pair of the smallest element-to-boom brackets (Item No. 60). These are marked with a number 4. Assemble these brackets on the boom 53¼ inches to the right of the rear driven element brackets. Refer to Figures 3 and 6. DO NOT tighten at this time.

10-15-20 Director and 15-20 Reflector —

Select two sets of medium sized element-to-boom brackets (Item No. 61) and loosely assemble these on the boom ends. The front set should be 68 inches to the left of the Front Driven Element brackets. The rear set should be 36 inches to the right of the 10 meter reflector brackets. Refer to Figures 3 and 6. DO NOT tighten now.

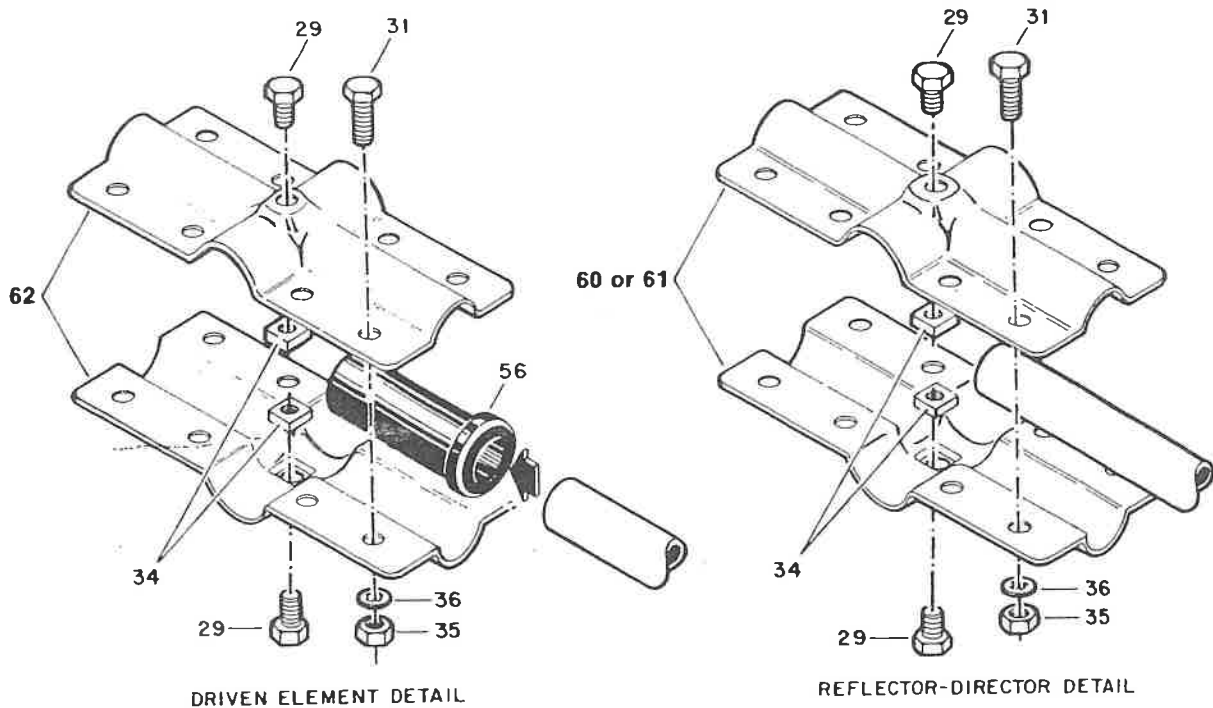

Item No.	Description	Item No.	Description
29	Bolt, hex head, 1/4"-20 x 3/8"	36	Lockwasher, internal, 1/4"
31	Bolt, hex head, 1/4"-20 x 3/4"	56	Insulator, Driven Element
34	Nut, square, 1/4"-20	60	Bracket, Element-to-Boom, #4
35	Nut, hex, 1/4"-20	61	Bracket, Element-to-Boom, #13
		62	Bracket, Element-to-Boom, #14

Figure 3
Element-to-Boom Bracket

Installation of Tubing Clamps

Select the proper size tubing clamp as shown in the chart. When installing the clamps, place the clamp near the tube end with the top of the clamp over the slot in the tube as shown in Figure 4.

After adjustment of the tubing lengths, tighten the clamp with a 5/16 inch nut driver, socket, or open end wrench until the tubing will not twist or telescope. **DO NOT OVERTIGHTEN.**

MA-0000-A-058

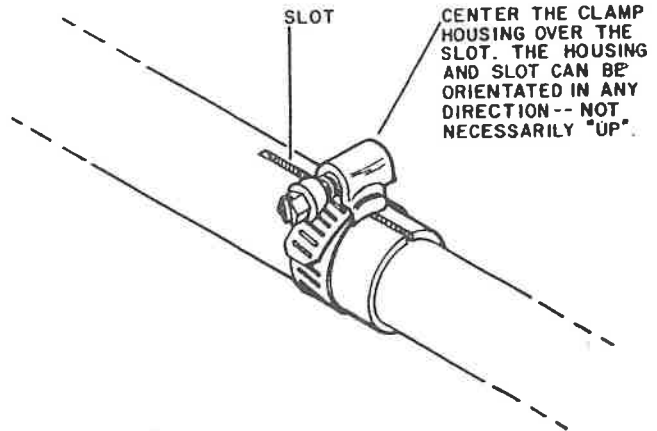
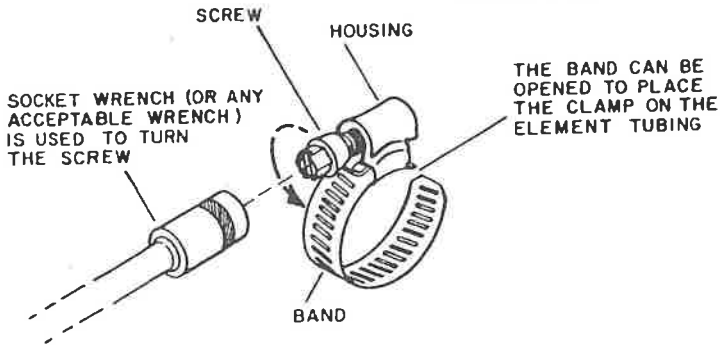

Part No.	Description	Fits Tubing Sizes
358756	Clamp, Size #6 all stainless steel 5/16" hex head screw	1/2 and 3/4"

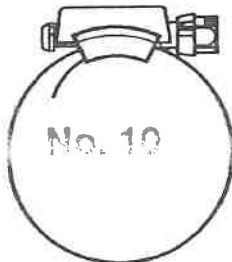

Part No.	Description	Fits Tubing Sizes
358757	Clamp, Size #10 all stainless steel 5/16 hex head screw	1"

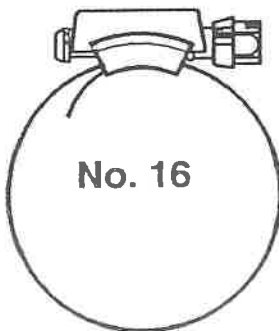

Part No.	Description	Fits Tubing Sizes
358758	Clamp, Size #16 all stainless steel 5/16 hex head screw	1 1/4"

Figure 4
Tubing Clamps

Element Assembly

Because of the broadband nature of the TH5/MK2, it is supplied with only one setting for use on all modes on all of the 20, 15, and 10 meter bands up to 29.4 MHz. If assembled correctly, the VSWR should be below 2:1 on any frequency on these bands.

NOTE: The VSWR will not exceed 3:1 between 29.4 and 29.7 MHz using the normal setting. However, the TH5/MK2 can be optimized for the frequency range of 29.4 to 29.7 MHz by using the following dimensions instead of those shown in Figure 6.

RDE2 = 29" (73.6 cm)

FDE2 = 22" (55.8 cm)

D2 = 23" (58.4 cm)

With these changes, the VSWR will not exceed 1.8:1 within the range of 29.4 to 29.7 MHz. The VSWR will remain less than 2:1 over most of the 20 and 15 meter bands.

The following steps will be in singular form. Do each element assembly step, first for one side of the boom and then for the other side. The dimensions shown in Figure 6 are in English units on the right side and metric on the left side. After each element is assembled to the boom, tighten the eight (8) ¼"-20 x ¾" bolts. After all elements are assembled, make sure that they all lie in a horizontal plane, then tighten the anchor screws securely. Ensure that all trap drain holes and tubing slots will be facing the ground.

Front Driven Element

Select the FDE-1 section (1 ¼" x 48") and a driven element insulator (see Figure 3). Slip the DE insulator on the unslotted end of the FDE-1, then slip the insulated end of the FDE-1 into the bracket which is 35 inches to the left of the mast bracket. Tighten the eight (8) screws to hold the element in place.

Install a #16 tubing clamp on the slotted end of the FDE-1 and insert the unslotted end of the FDE-2 (1 1/8" x 31 7/8") to the dimension shown in Figure 6. Tighten the #16 tubing clamp securely and recheck the FDE-2 dimension.

Assemble the remainder of the Front Driven Element in the same manner using dimensions from Figure 6. Use Figure 5 and Detail A as guides. Use 10 meter trap Part Number 878749 and 15 meter trap Part Number 878637 in this assembly. Make sure all insulators and trap caps are firmly seated.

NOTE: The drain holes and slots should be facing the ground. Also, the trap labels should be on the boom side of the trap. See Figure 5.

Rear Driven Element

Select the RDE-1 section (1 ¼" x 48") and a driven element insulator. Slip the DE insulator on the unslotted end of the RDE-1, then slip the insulated end of the RDE-1 into the bracket which is 20 inches to the right of the mast bracket. Make sure the insulator seats completely onto the tube and into the bracket. Tighten the eight (8) screws to hold the element in place.

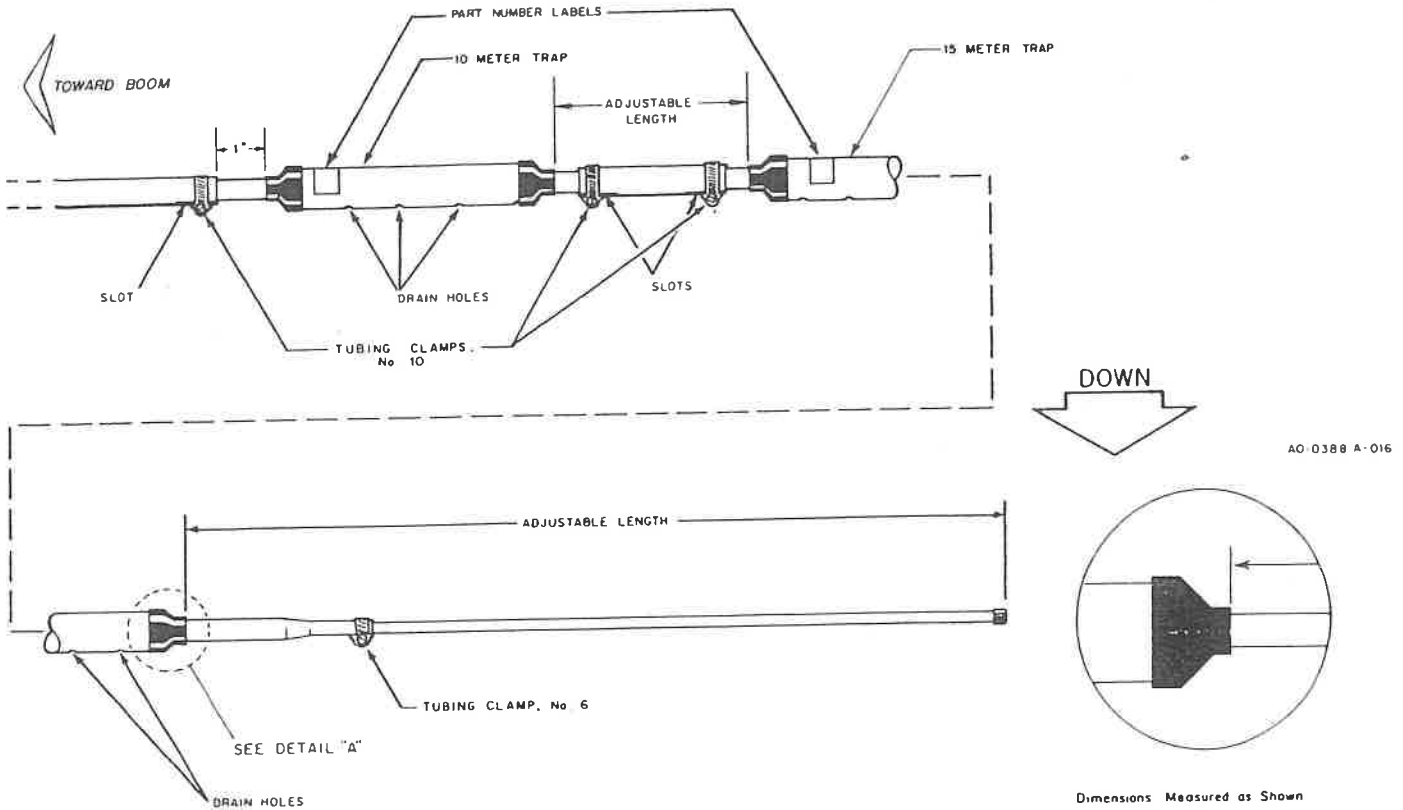

**Figure 5
Trap Detail**

**DETAIL A
Trap Detail — Measuring Point**

Install a #16 tubing clamp on the slotted end of the RDE-1 and insert the unslotted end of the RDE-2 (1 1/8" x 36") to the dimension shown in Figure 6. Tighten the #16 tubing clamp securely and recheck the RDE-2 dimension. Assemble the remainder of the Rear Driven Element in the same manner using dimensions from Figure 6. Use Figure 5 and Detail A as guides. Use the same traps as on the Front Driven Element.

10 Meter Reflector Element

Select the R2-1 section (7/8" x 55") and slip the unswaged end of the R2-1 completely into the bracket (Item 60) assembled on the boom 53 1/4" inches to the right of the Rear Driven Element. Tighten the eight (8) bolts to hold the element onto the boom.

Assemble the remainder of the 10 meter reflector as shown in Figure 6 using #6 tubing clamps. Tighten all element tubing clamps with the slots facing the ground and recheck all dimensions. **DO NOT OVERTIGHTEN.**

15-20 Meter Reflector Element

Select the R-1 section (1 1/4" x 83") and slip the unslotted end completely into the bracket (Item No. 61) assembled on the boom 36 inches to the right of the 10 meter reflector. Tighten the eight (8) bolts to hold the element onto the boom.

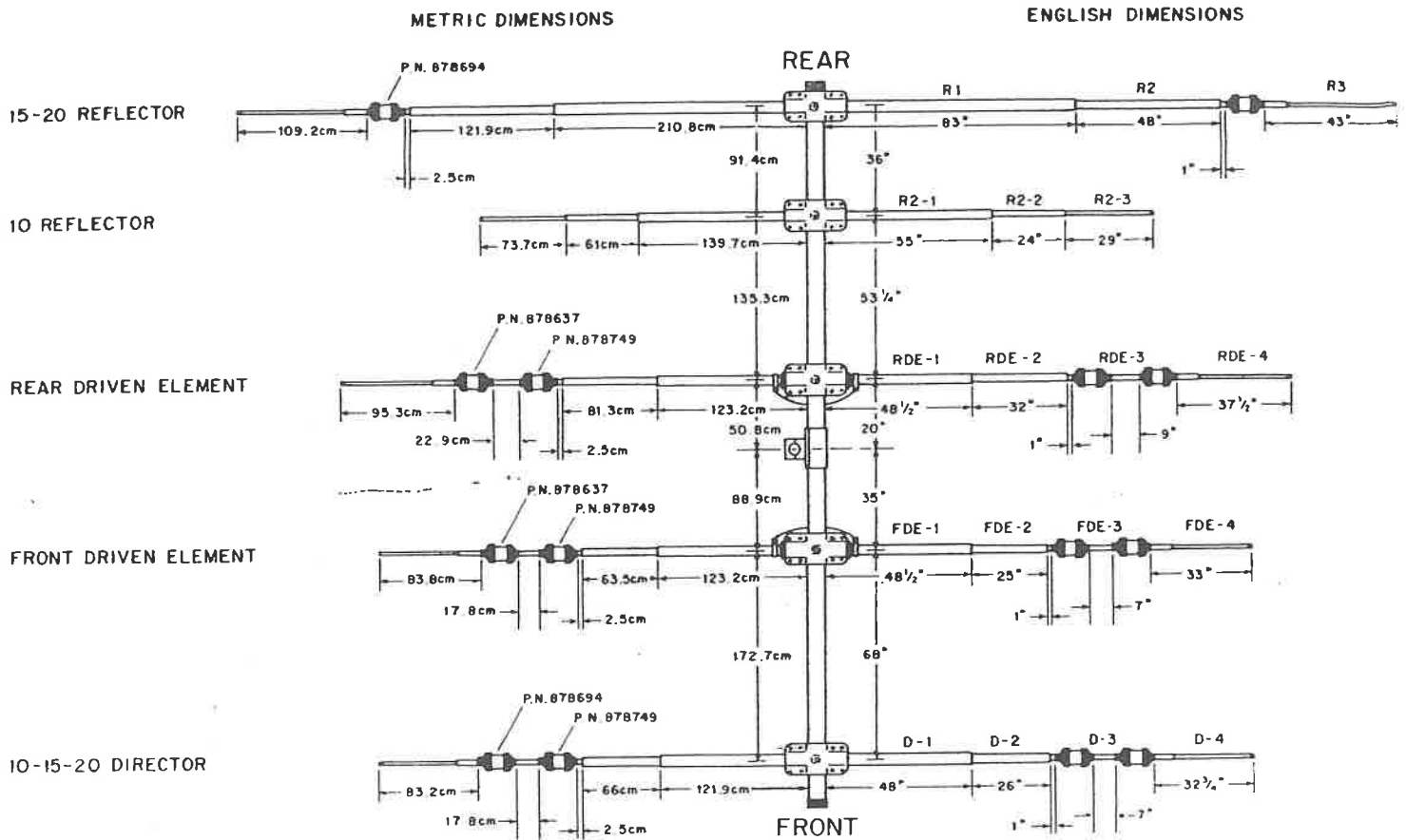

Item No.	Designator	Part Number	Description	Item No.	Designator	Part Number	Description
1	R1	871098	1 1/4" x 83"	11	RDE-3	190603	1" x 8"
2	R2	190303	1 1/8" x 52"	10	FDE-2 & D-2	190312	1 1/8" x 31 1/8"
3	R3	171153	7/16" x 37"	9	FDE-3 & D-3	190606	1" x 6"
4	R2-1	190206	7/8" x 55"	12	FDE-4 & D-4	178558	7/16" x 28"
5	R2-2	190006	5/8" x 26"	13	15 Meter Trap	878694	15 Meter Trap
6	R2-3 & RDE-4	176216	7/16" x 32"	14	10 Meter Trap	878749	10 Meter Trap
7	RDE-1, FDE-1, D-1	190900	1 1/4" x 48"	15	15 Meter DE Trap	878637	15 Meter DE Trap
8	RDE-2	190311	1 1/8" x 36"				

Figure 6
Element Assembly and Antenna Dimensions

Assemble the remainder of the 15-20 meter reflector, as shown in Figure 6, using #16, #10 and #6 tubing clamps. Use trap Part Number 878694 and install with the drain holes facing the ground. Use Figure 5 and Detail A as guides. Tighten all element tubing clamps and recheck all dimensions. DO NOT OVERTIGHTEN.

10-15-20 Meter Director Element

Select the D1 section (1¼" x 48") and slip the unslotted end completely into the bracket (Item No. 61) assembled on the boom 68 inches to the left of the Front Driven Element. Tighten the eight (8) bolts to hold the element onto the boom.

Assemble the remainder of the 10-15-20 meter director as shown in Figure 6 using #16, #10 and #6 tubing clamps. Use Trap Part Number 878749 and 878694 and install with the drain holes facing the ground. Use Figure 5 and Detail A as guides. Tighten all element tubing clamps and recheck all dimensions. DO NOT OVERTIGHTEN.

Final Element Assembly

After all elements have been installed, align all elements in the horizontal plane and tighten all anchor bolts (see Figure 3). You may wish to temporarily assemble the entire boom-to-mast assembly with a short length of mast material to ensure that all elements are assembled perpendicular (at 90°) to the mast.

Select the dampener rope and cut it into two equal lengths of six feet each. Slip a rope into the end of each 10 meter reflector element. With about a 1/2" of rope extending from the element end, separate the fibers and fold them back over the element end. Refer to Figure 7. Now slip a 7/16" caplug over the element and rope. The rope inside the element will dampen vibrations caused by low wind speeds. Place a 7/16" caplug on each end of the trapped elements. Select the 2" caplugs and place one on each boom end. Check all element spacings and dimensions and tighten all of the bolts before continuing.

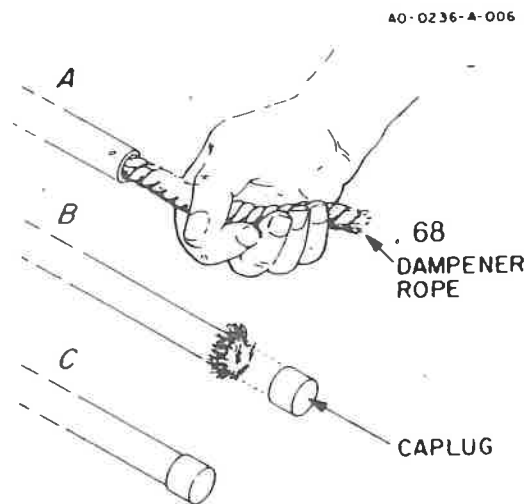

Figure 7
Rope Dampener

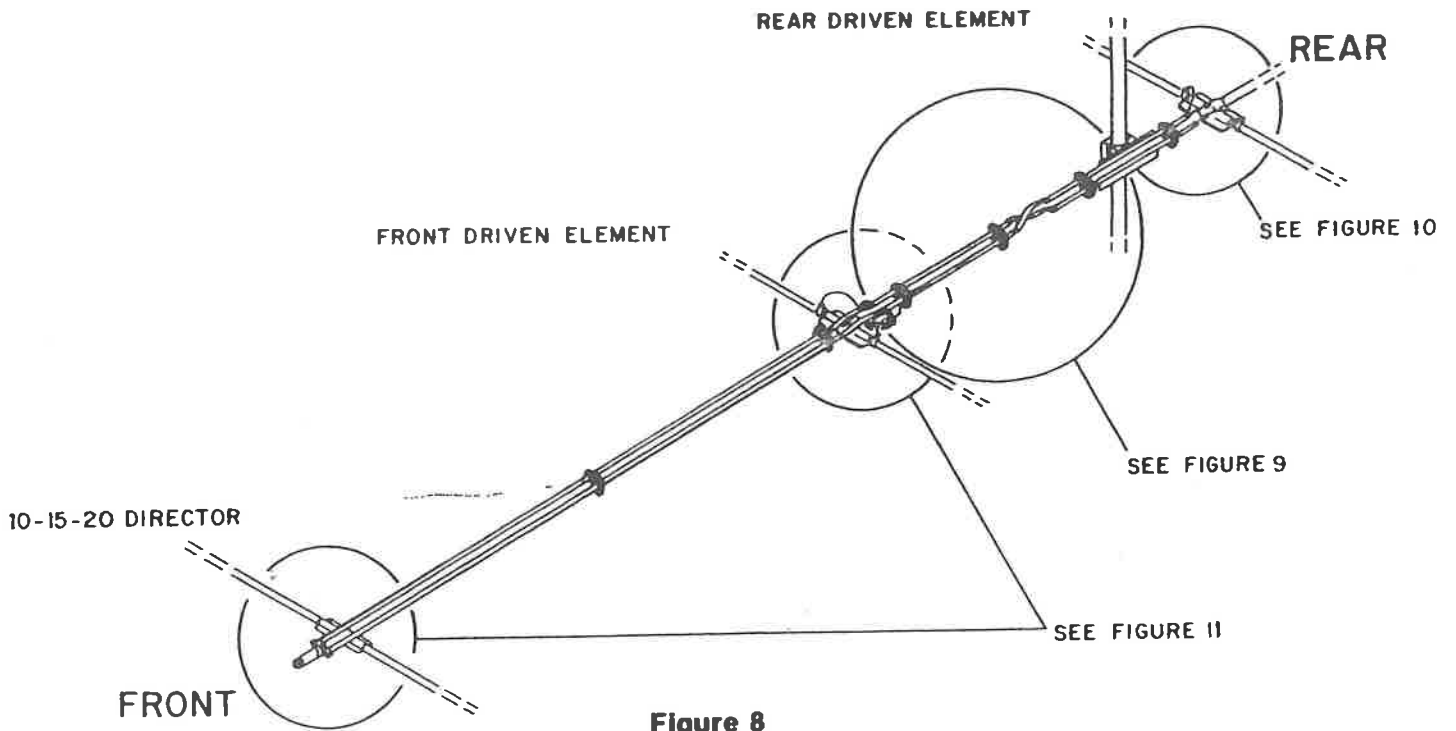

Figure 8
Overall View of Beta Match and Phasing Tubes

Phasing Line Assembly

Select the four (4) $\frac{3}{4}$ " x 23" phasing tubes (Item No. 63), two (2) crossover straps (Item No. 43), four (4) beta support clamps (Item No. 49), four (4) beta support insulators (Item No. 54), four (4) beta top insulators (Item No. 55), and associated hardware as shown in Figure 9. Assemble the rear pair of phasing tubes to the boom as shown in Figures 9 and 10. Position the rear ends of the $\frac{3}{4}$ " x 23" tubes $3\frac{1}{2}$ inches from the center of the Rear Driven Element bracket. Position the tubes so that the drilled holes are away from the boom. Rotate this assembly on the boom so that the tubes will just clear the mast bracket. Tighten the four (4) #10-24 x 2" bolts which hold this assembly to the boom.

Select the two (2) crossover straps and install on the previously installed phasing tubes with $\frac{1}{4}$ "-20 x $\frac{3}{4}$ " bolts, lockwashers, and square nuts. DO NOT tighten completely at this time. See Figure 9.

Select the remaining two (2) phasing tubes, two (2) beta support clamps, two (2) beta support insulators, two (2) beta top insulators, and associated hardware as shown in Figure 9. Assemble the front pair of phasing tubes to the boom as shown in Figure 9. Rotate the tubes so that the drilled holes are away from the boom. Slide the assembly on the boom until the crossover straps can be attached. The ends of the phasing tubes should be about $3\frac{1}{16}$ inches apart. Attach the crossover straps to the front phasing tubes and tighten the $\frac{1}{4}$ "-20 x $\frac{3}{4}$ " bolts at this time. Loosen and rotate the two assemblies on the boom and install the top two (2) mast bracket bolts ($\frac{5}{16}$ "-18 x 5", Item No. 16) as shown in Figure 9. Rotate the two (2) assemblies back into place and position them so that the phasing tubes are $\frac{3}{4}$ of an inch from the top flange of the mast bracket. You should be able to insert your fingers between the phasing tube and mast bracket and run them along the phasing tube. Tighten the #10-24 x 2" bolts which hold the assemblies to the boom.

Item No.	Description
16	Bolt, hex head, 5/16"-18 x 5"
21	Bolt, hex head, #10-24 x 2"
25	Nut, hex, #10-24
27	Lockwasher, internal, #10
31	Bolt, hex head, 1/4"-20 x 3/4"
34	Nut, square, 1/4"-20
36	Lockwasher, internal, 1/4"
43	Crossover Strap
49	Clamp, Beta Support
54	Insulator, Beta Support (bottom)
55	Insulator, Beta Support (top)
63	Phasing Tubes, 3/4" x 23", drilled
66	Clamp, Boom-to-Bracket
67	Bracket, Casting-to-Boom

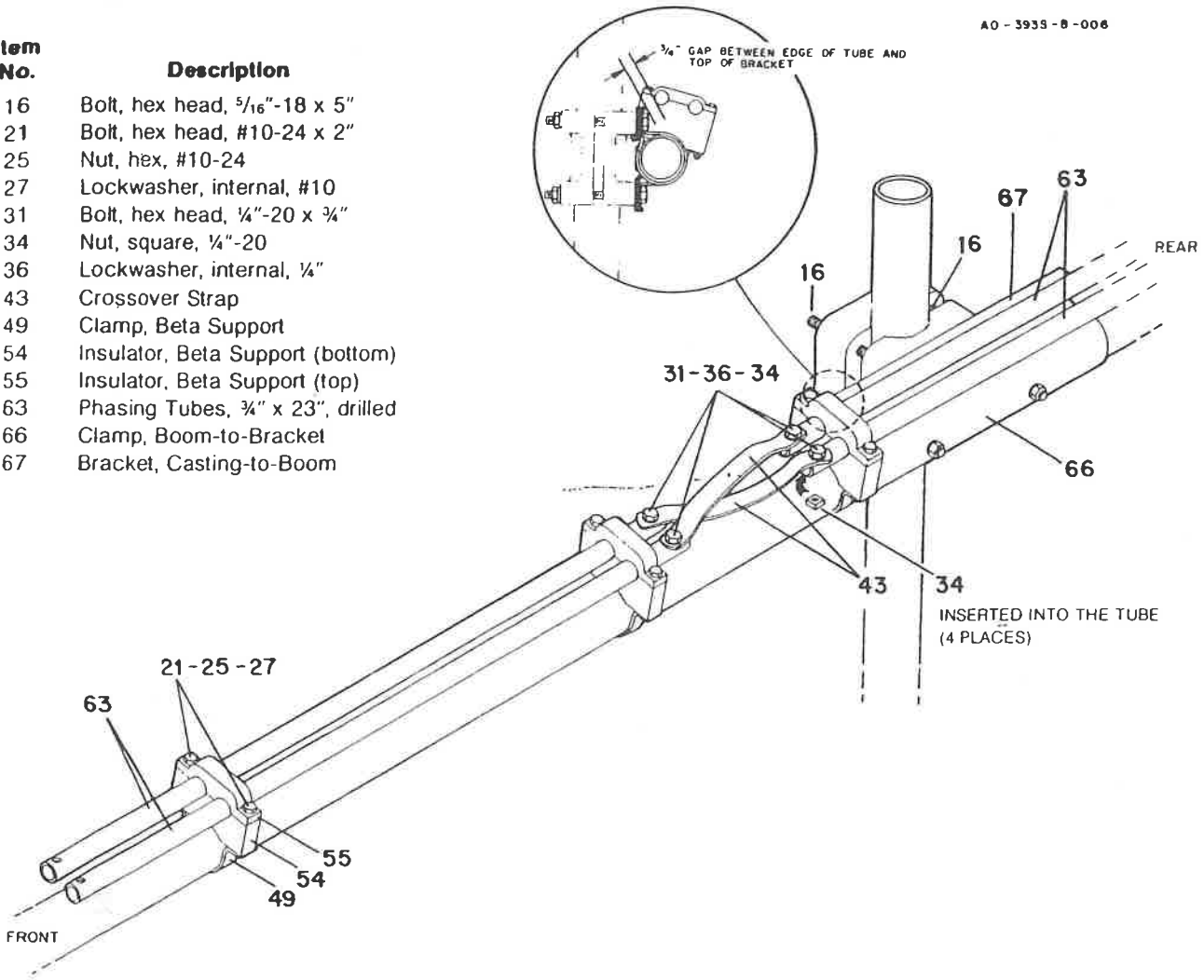
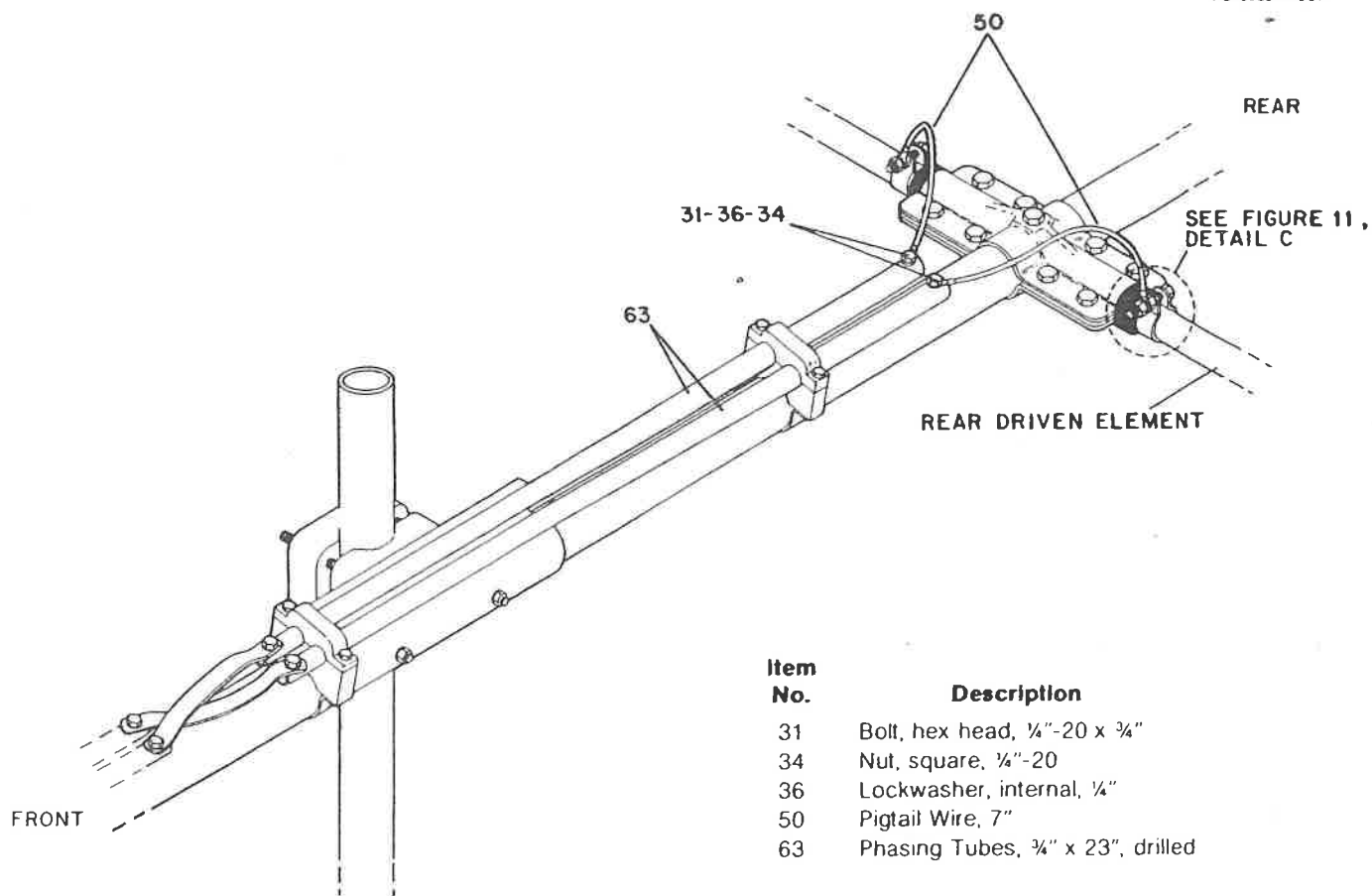

Figure 9
Crossover Straps

Select two (2) 1 1/4" aluminum tubing clamps, two (2) 7" pigtail assemblies and associated hardware as shown in Figure 10. Install on the Rear Driven Element as shown and tighten all bolts securely.

Beta Match Assembly

Select the two (2) beta match tubes (3/4" x 70"), two (2) beta support clamps, two (2) beta support insulators, two (2) beta top insulators, and associated hardware and clamps as shown in Figure 11 and Details A and B. Assemble the beta match tubes and shorting clamp assembly as shown in Figure 11 and Details A and B. The shorting clamp should be flush with the ends of the beta match tubes. The opposite ends of the beta tubes should be approximately 2 7/8 inches from the center of the Front Driven Element bracket. The final dimension will depend on the attachment of the beta tubes and the phasing tubes through the beta feed jumper straps.



Item No.	Description
31	Bolt, hex head, ¼"-20 x ¾"
34	Nut, square, ¼"-20
36	Lockwasher, internal, ¼"
50	Pigtail Wire, 7"
63	Phasing Tubes, ¾" x 23", drilled

Figure 10
Pigtail to Rear Driven Element

Feedpoint Assembly

Select the beta feed jumper straps, feed straps and associated hardware as shown in Figure 11. Assemble the beta feed jumper straps and feed straps to the phasing tubes with two (2) ¼"-20 x ¾" bolts, lockwashers, and nuts. See Figure 11. Tighten these snugly. Slide the beta tube assembly on the boom until the beta feed jumper straps can be attached. Attach the jumper straps to the beta tubes with ¼"-20 x ¾" bolts, lockwashers, and square nuts and tighten all bolts to hold the beta tubes in place.

Select the JR (6½") pigtail assembly wires, 1¼" tubing clamps and associated hardware as shown in Figure 11. Expand the 1¼" clamps slightly and slip onto the 1¼" tubing near the Front Driven Element insulators. Position the tubing clamps flush with the insulators and secure to the tubing using ¼"-20 x 1¼" bolts, lockwashers, and nuts. Slip one end of a pigtail assembly over each 1¼" bolt and secure using another lockwasher and nut. Route the pigtail up and over to the feed strap. Secure the pigtail wires to the feed strap using #10-24 x ½" bolts, lockwashers, and nuts.

Attach the BN-86 balun to the boom, as shown in Figure 11, using the U-bolt and #10-24 lockwashers and nuts. The balun will be tipped to one side in order to line up with both feed straps. Attach both feed straps to the balun using ¼"-20 x ¾" bolts and lockwashers. Tighten all bolts securely.

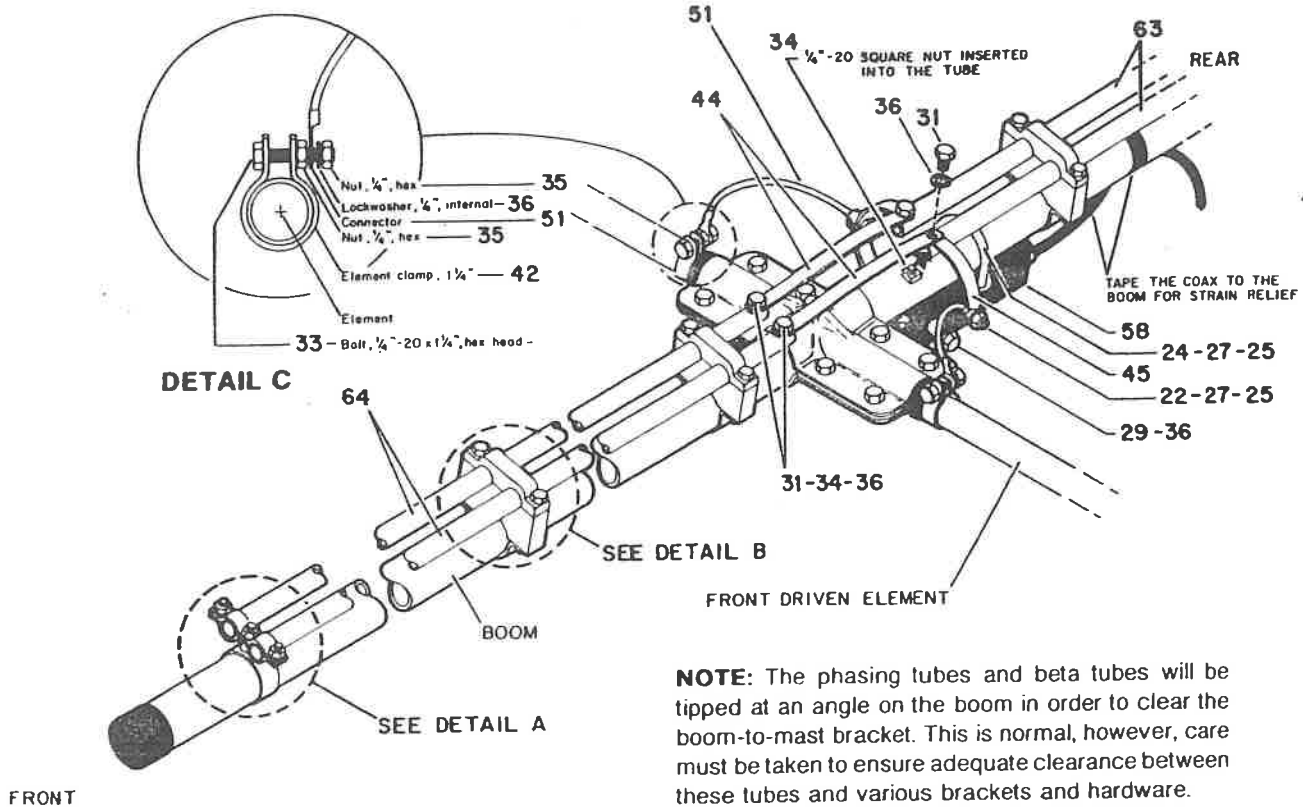

NOTE: The phasing tubes and beta tubes will be tipped at an angle on the boom in order to clear the boom-to-mast bracket. This is normal, however, care must be taken to ensure adequate clearance between these tubes and various brackets and hardware.

NOTE: The JR pigtail (Item No. 51) assembly is the shorter of the two types supplied with this product.

Item No.

Description

- 21 Bolt, hex head, #10-24 x 2"
- 22 Bolt, hex head, #10-24 x 5/8"
- 24 U-Bolt, #10-24 x 2 1/2" x 2 3/4"
- 25 Nut, hex, #10-24
- 27 Lockwasher, internal, #10
- 28 Bolt, hex head, #10-24 x 1 1/2"
- 29 Bolt, hex head, 1/4"-20 x 3/8"
- 30 Bolt, hex head, 1/4"-20 x 1 1/2"
- 31 Bolt, hex head, 1/4"-20 x 3/4"
- 33 Bolt, hex head, 1/4"-20 x 1 1/4"
- 34 Nut, square, 1/4"-20
- 35 Nut, hex, 1/4"-20
- 36 Lockwasher, internal, 1/4"
- 42 Clamp, Tubing, 1 1/4"
- 44 Beta Feed Jumper
- 45 Feed Strap
- 46 Strap, Boom-to-Beta, 2" I.D.
- 47 Sleeve, Beta Shorting
- 48 Strap, Beta Shorting, 3/8" radials
- 49 Clamp, Beta Support
- 51 Pigtail Wire, Jr., 6 1/2"
- 54 Insulator, Beta Support (bottom)
- 55 Insulator, Beta Support (top)
- 58 Balun, BN-86, 50 ohm
- 63 Phasing Tubes, 3/4" x 23", drilled
- 64 Beta Tubes, 3/4" x 70", drilled

AO-3935-A-012

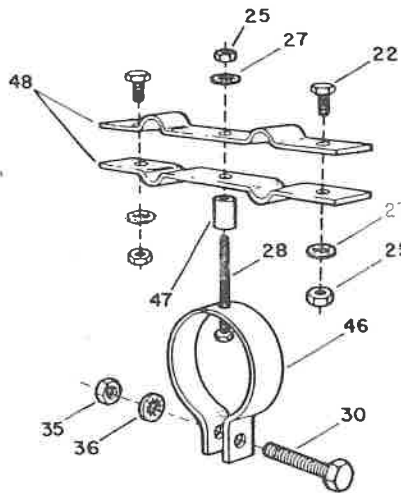

DETAIL A
Beta Shorting Clamp Assembly

AO-3935-A-011

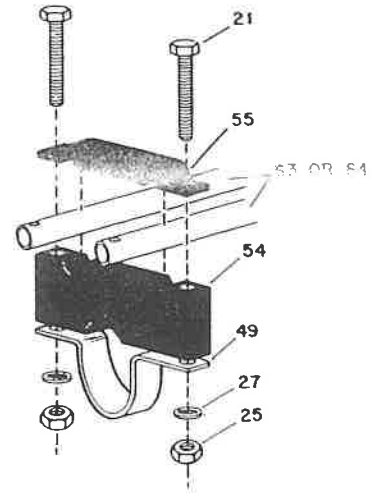

DETAIL B
Beta Support Clamps and Insulator Assembly

Figure 11
Pigtail to Balun Connection and Front Driven Element

Final Assembly Checklist

1. Check the distances between elements as shown in Figure 6.
2. Check to ensure all elements lie in the same plane and will be perpendicular (at 90 degrees) to the mast when installed.
3. Check the exposed element lengths against the dimensions shown in Figure 6. Check both sides of each element. Ensure that the trap caps are firmly seated.
4. Check the tightness of each element tubing clamp. You should not be able to turn an element that is securely clamped with a larger element.
5. Securely tighten all bolts used in the element-to-boom brackets.
6. Securely tighten all bolts used in the phasing tube and beta tube assemblies.
7. Ensure that all trap drain holes and tubing slots are facing the ground.

CHAPTER 4

Installation

IMPORTANT

The TH5/MK2 is a moderately large antenna and requires some consideration as to how you are going to get it to the top of the tower. Thoroughly read this section before beginning to install your antenna.

Installation On a Crank-Up Tower

Crank the tower down completely or as low as it will go, and block all sections from moving by using a 2" x 4" piece of wood or a solid iron bar for heavier towers. The block should be inserted through the lattice structure before the tower is completely down, then the tower can be cranked down until the block takes the weight off of the winch.

Use a ladder to reach the top of the tower. **NEVER CLIMB THE LATTICE STRUCTURE OF ANY CRANK-UP TOWER!** Attach the mast to the tower and rotator. (The cast aluminum boom-to-mast brackets should be installed on the mast as shown in Figure 1 in Chapter 3.) Attach a gin pole to the tower to assist in lifting the TH5/MK2.

Attach the lifting rope to the balance point of the antenna. Be careful not to damage the phasing line assembly next to the boom-to-mast clamp. The lifting rope should be fed through the gin pole or other pulley arrangement attached to the tower. The other end should be at ground level, available to the ground crew for lifting. Guide ropes may be loosely looped over the boom ends and used by the ground crew to guide the antenna away from the tower and ladder. Each guide rope's two loose ends should be held by the ground crew, so that the guide rope can be retrieved.

Attaching the Antenna to the Mast

When the antenna reaches the mast bracket, the two (2) 5" bolts should be inserted through the top two holes in the mast bracket and secured using 5/16"-18 lockwashers and nuts. The other two remaining 5/16"-18 x 5" bolts should now be installed and secured with the same lockwashers and nuts. Tighten all bolts securely. You may wish to use a deep well socket set to tighten these bolts.

NOTE:

The use of two split lockwashers on the 5" bolts may be necessary to properly tighten the clamp on a 2" mast. Additional washers may be needed if masts is slightly smaller than 2" are used.

Other Types of Towers

When installing the TH5/MK2 on a guyed tower, you may wish to use a different guide system. If you have insulators on your guy wires, you will need to keep the antenna away from the guy wires as well as the tower. You may wish to use two ropes attached together at the top of the tower and attached to the ground about 15 feet apart. These two ropes can then be used to slide the antenna on as it is also being lifted. The two ropes will need to be far enough from the tower base to allow some sag and still support the antenna away from the guy wires.

WARNING

Installation of this product near power lines is dangerous. For your safety follow the instructions.

Lightning Protection

For proper lightning protection, you must ground your antenna supporting structure. Grounding will ensure noise free operation and low SWR. A proper ground consists of a ½" x 8' copper clad steel ground rod driven into the ground approximately 12 inches away from the concrete tower base. Connect the tower to the ground rod using #8 copper wire and commercial non-corrosive ground clamps.

Attachment of Feedline

Use a good quality 50 ohm coaxial transmission line such as Belden 8214 (foam) or Belden 8237, 8267 or 9251 (solid). Take extra care when soldering connectors to foam dielectric coaxial cable. Weatherproof all connectors which will be exposed to rain or ice with Coax-Seal® or another similar substance.

Attach the transmission line to the BN-86 balun and tighten the connector securely. Tape the coax to the boom and mast to ensure good strain relief.

For protection against lightning, it is highly recommended that you use a Hy-Gain Model LA-1 Lightning Arrestor. The Model LA-1 is available at your Hy-Gain dealer. The LA-1 should be installed near your ground rod and connected to the ground rod with #6 or #8 copper wire. Remember that lightning will take the most direct path to ground.

VSWR Curves

These VSWR Curves are typical for this antenna mounted 70 feet above the ground, horizontally polarized. Similar curves can be expected for this antenna mounted between 30 and 100 feet above the ground. *DO NOT TRY TO TUNE THIS ANTENNA FOR LOW VSWR AT GROUND LEVEL.* Higher VSWR can be expected if mounted at less than 30 feet or above a roof or large metallic structure. Forty (40) and eighty (80) meter wire dipoles should be kept at least 6 feet below this antenna.

Guy wires should be broken up into non-resonant lengths and insulated from the tower if mounted within 10 feet of the top of the tower.

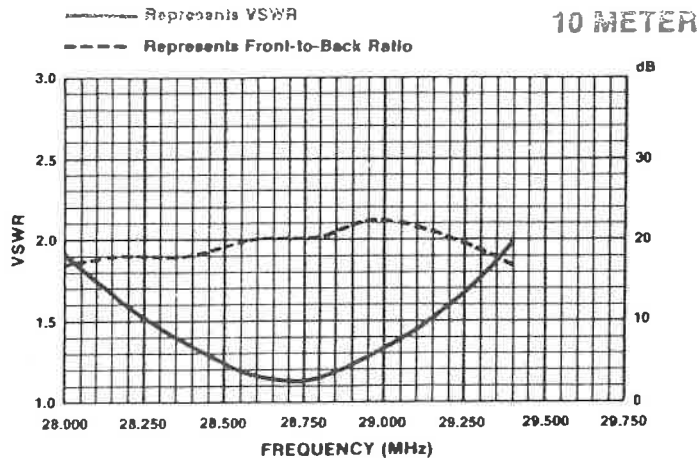
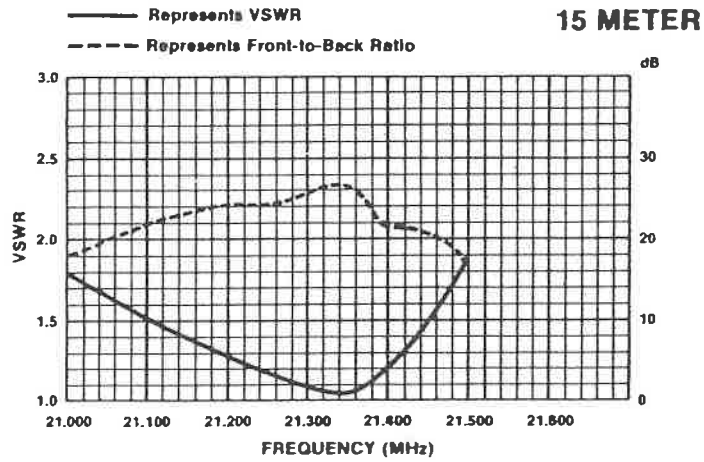
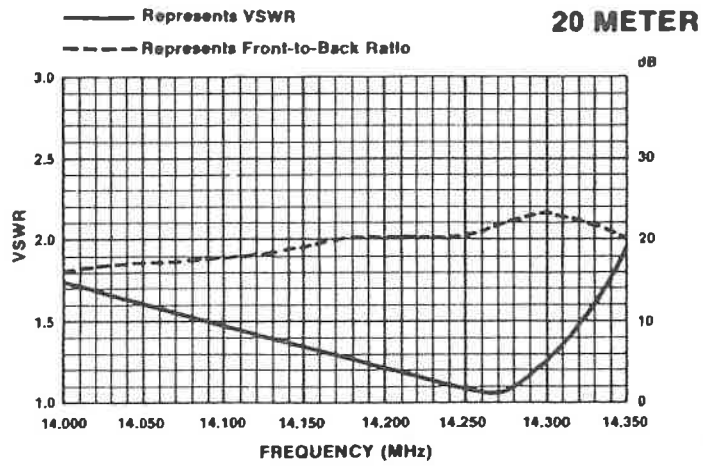

VSWR/Front-to-Back Charts

CHAPTER 5

Operation

Connect the other end of your transmission line to a good quality SWR meter or ThruLine® wattmeter and then to your radio. While using lower power (less than 200 watts output), check the VSWR across each band from 14.0 to 29.7 MHz. Record this information for future reference. See Attachment 1 on page 31 of this manual. Check the VSWR periodically to ensure proper operation.

The front-to-back ratio may be checked by using a steady carrier transmitted by a local station (at least a ½ mile away). The receiver AGC should be turned off when measuring. The front-to-back ratio may be affected by the proximity of metallic structures or guy wires less than 10 feet below the antenna.

This completes your installation of the TH5/MK2. Happy Dx'ing!

CHAPTER 6

Troubleshooting

If you encounter problems with the operation of your TH5/MK2, follow these steps to isolate the cause of your problem.

Usually you can isolate problems that occur in either your antenna or feedline / feedpoint. If you experience high VSWR on all bands, your problem is probably in the feedline or balun. If you experience high VSWR on some bands but not on all bands, look for problems in the antenna element lengths or traps or nearby resonant structures.

SYMPTOM	POSSIBLE CAUSES
Consistently high VSWR on all bands.	Balun damaged by lightning or excessive power. Shorted coaxial connector. Water inside of balun or transmission line.
High VSWR dependent upon direction of beam.	Resonant guy wires too close to antenna. Metallic structures or wiring too close to antenna.
Intermittent high VSWR not dependent on weather or power level or direction of beam or band selection.	Loose connection on feed system, matching system or transmission line.
High VSWR after a rainshower or with high humidity.	Trap(s) installed with drain holes up instead of down. Tubing installed with slots up instead of down. Water inside of balun or coax cable.
High VSWR with High power, low VSWR with Low power.	Balun damaged or defective.
Low VSWR, but only near band edge(s).	Loose coaxial connection on transmission line.
High VSWR on 10 meters only.	Feedpoint or phasing lines not assembled correctly.
High VSWR on only 20 meters or only 15 and 20 meters.	Trap(s) damaged or defective. Resonant guy wires or nearby metallic structure. Another HF antenna too close. Antenna not assembled correctly.
High VSWR at band edges.	Inadequate tower grounding system.

CHAPTER 7

Service Information

If you are unable to resolve your problem or if you need to order replacement parts, you should contact the Hy-Gain Customer Service Department.

You should fully research your problem by going through the Troubleshooting Guides in Chapter 6 before you contact the Customer Service Department. You should also record your VSWR across all three bands before calling

You should retain your sales receipt or other proof of purchase for antennas that are still under warranty.

All requests, inquires, warranty claims, or for ordering replacement parts, contact:

Hy-Gain
308 Industrial Park Road
Starkville, Mississippi 39759
USA

Phone: 662-323-9538

FAX: 662-323-6551

METRIC DIMENSIONS

ENGLISH DIMENSIONS

AO-3935-C-003

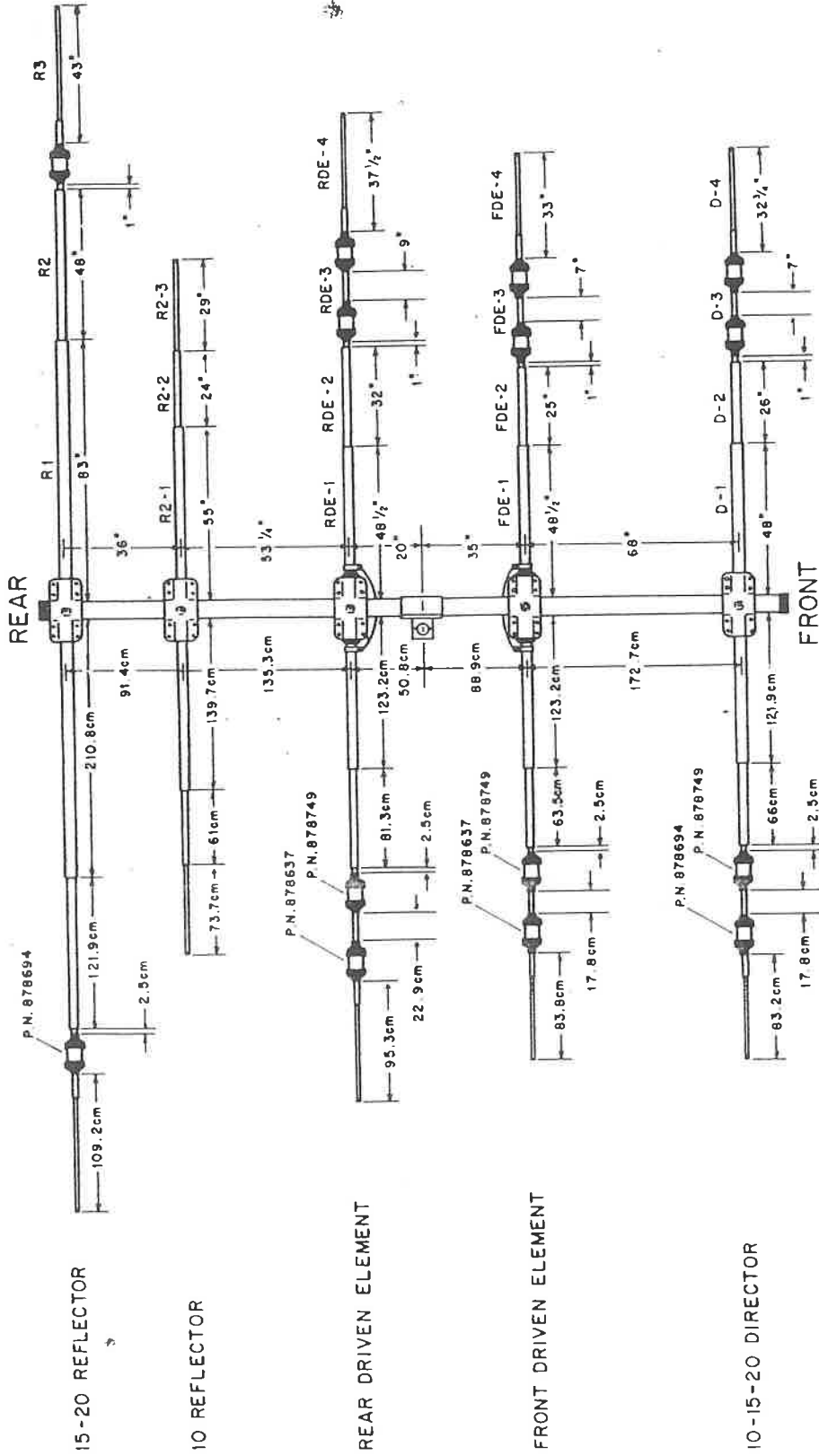

Item No.	Designator	Part Number	Description	Item No.	Designator	Part Number	Description
1	R1	871098	1 1/4" x 83"	11	RDE-3	190603	1" x 8"
2	R2	190303	1 1/8" x 52"	10	FDE-2 & D-2	190312	1 1/8" x 31 1/2"
3	R3	171153	7/16" x 37"	9	FDE-3 & D-3	190606	1" x 6"
4	R2-1	190206	7/8" x 55"	12	FDE-4 & D-4	178558	7/16" x 28"
5	R2-2	190006	5/8" x 26"	13	15 Meter Trap	878694	15 Meter Trap
6	R2-3 & RDE-4	176216	7/16" x 32"	14	10 Meter Trap	878749	10 Meter Trap
7	RDE-1, FDE-1, D-1	190900	1 1/4" x 48"	15	15 Meter DE Trap	878637	15 Meter DE Trap
8	RDE-2	190311	1 1/8" x 36"				

CHAPTER 8 PARTS LIST

Item No.	Part No.	Description	Qty
1	871098	Tubing Assy, aluminum, R1, 1 1/4" x 83"	2
2	190303	Tube, aluminum, R2, 1 1/8" x 52"	2
3	171153	Tube, aluminum, R3, 7/16" x 37"	2
4	190206	Tube, aluminum, R2-1, 7/8" x 55"	2
5	190006	Tube, aluminum, R2-2, 5/8" x 26"	2
6	176216	Tube, aluminum, R2-3 & RDE-4, 7/16" x 32"	4
7	190900	Tubing Assy, aluminum, RDE-1, FDE-1 & D-1, 1 1/4" x 48" ...	6
8	190311	Tube, aluminum, RDE-2, 1 1/8" x 36"	2
9	190606	Tube, aluminum, FDE-3 & D-3, 1" x 6"	4
10	190312	Tubing Assy, aluminum, FDE-2, 1 1/8" x 31 7/8"	4
11	190603	Tube, aluminum, RDE-3, 1" x 8"	2
12	178558	Tube, aluminum, FDE-4 & D-4, 7/16" x 28"	4
13	878694	Trap, 15 Meter	4
14	878749	Trap, 10 Meter	6
15	878637	Trap, 15 Meter, Driven Element	4
	872119-1	Parts Pack 393S, 5/16" & No. 10 Hardware	1
16	500349	Bolt, 5/16"-18 x 5", hex head, stainless steel	4
17	500392	Bolt, 5/16"-18 x 3", hex head, stainless steel	2
18	506968	Bolt, 5/16"-18 x 2 3/4", hex head	2
19	555747	Nut, hex, 5/16"-18	9
20	564792	Lockwasher, split, 5/16"	13
21	500157	Bolt, #10-24 x 2", hex head	12
22	500160	Bolt, #10-24 x 5/8", hex head	6
23	5142400	Bolt, 5/16"-18 x 4 hex head	1
24	540087	U-Bolt, #10-24 x 2 1/2" x 2 3/4, stainless Steel	1
25	554071	Nut, #10-24, hex	24
26		(Not Used)	
27	565697	Lockwasher, #10 internal	20
28	500159	Bolt, #10-24 x 1 1/2"	2
	872118-1	Parts Pack 393S, 1/4" Hardware	1
29	500156	Bolt, 1/4"-20 x 3/8", hex head	14
30	504098	Bolt, 1/4"-20 x 1 1/2", hex head	1
31	505266	Bolt, 1/4"-20 x 3/4", hex head	58
32	505734	Bolt, 1/4"-20 x 2 1/2", hex head	4
33	506518	Bolt, 1/4"-20 x 1 1/4", hex head	4
34	551367	Nut, 1/4"-20, square	22
35	554099	Nut, 1/4"-20, hex	60
36	562961	Lockwasher, internal, 1/4"	68
37		(Not Used)	
	878681	Parts Pack 393S, Tubing Clamps	1
38	358756	Clamp, No. 6 Tubing	12
39	358757	Clamp, No. 10, Tubing	20
40	358758	Clamp, No. 16, Tubing	8
41		(Not Used)	

PARTS LIST (Cont.)

Item No.	Part No.	Description	Qty
	871889	Parts Pack TH5MK2, Straps	1
42	168695	Clamp, Tubing, 1 1/4"	4
43	170452	Crossover Strap	2
44	170453	Beta Feed Jumper	2
45	170454	Feed Strap	2
46	171077	Strap, Boom-to-Beta, 2" I.D.	1
47	171131	Sleeve, Beta Shorting	1
48	171162	Strap, Beta Shorting, 3/8" radials	2
49	177888	Clamp, Beta Support	6
50	871508	Pigtail wire, 7"	2
51	878561	Pigtail Wire, Jr., 6 1/2"	2
	871890	Parts Pack TH5MK2, Insulators	1
52	455625	Caplug, 2"	2
53	455644	Caplug, 7/16"	14
54	465595	Insulator, Beta Support (bottom)	6
55	465600	Insulator, Beta Support (top)	6
56	465833	Insulator, Driven Element	4
57	170466	Tube, Boom, 2" x 75"	2
58	873424	Balun, BN-86, 50 ohm	1
59	102734	Mast Bracket, cast aluminum	2
60	163764	Bracket, Element-to-Boom, #4	2
61	165919	Bracket, Element-to-Boom, #13	4
62	165920	Bracket, Element-to-Boom, #14	4
63	170447	Phasing Tubes, 3/4" x 23", drilled	4
64	170456	Beta Tubes, 3/4" x 70", drilled	2
65	170465	Tube, Boom, 2" x 41", swaged	2
66	172732	Clamp, Boom-to-Bracket	1
67	172735	Bracket, Casting-to-Boom	1
68	691138	Rope, polyethylene, 5/32" x 12'	1
69	850050	Coax-Seal®	1

VSWR RECORD

Type of VSWR Meter _____

Frequency	Date _____	Date _____	Date _____
	VSWR	VSWR	VSWR
14.00	_____	_____	_____
14.10	_____	_____	_____
14.20	_____	_____	_____
14.30	_____	_____	_____
14.35	_____	_____	_____
21.00	_____	_____	_____
21.10	_____	_____	_____
21.20	_____	_____	_____
21.30	_____	_____	_____
21.40	_____	_____	_____
21.45	_____	_____	_____
28.00	_____	_____	_____
28.25	_____	_____	_____
28.50	_____	_____	_____
28.75	_____	_____	_____
29.00	_____	_____	_____
29.25	_____	_____	_____
29.50	_____	_____	_____
29.70	_____	_____	_____

Height of Antenna: _____

Types of antennas or guy wires
also attached to same tower: _____

Notes:

hy-gain® LIMITED WARRANTY

hy-gain Warrants to the original owner of this product, if manufactured by *hy-gain* and purchased from an authorized dealer or directly from *hy-gain* to be free from defects in material and workmanship for a period of 12 months for rotator products and 24 months for antenna products from date of purchase provided the following terms of this warranty are satisfied.

1. The purchaser must retain the dated proof-of-purchase (bill of sale, canceled check, credit card or money order receipt, etc.) describing the product to establish the validity of the warranty claim and submit the original or machine reproduction of such proof-of-purchase to *hy-gain* at the time of warranty service. *hy-gain* shall have the discretion to deny warranty without dated proof-of-purchase. Any evidence of alteration, erasure, or forgery shall be cause to void any and all warranty terms immediately.
2. *hy-gain* agrees to repair or replace at *hy-gain*'s option without charge to the original owner any defective product under warranty, provided the product is returned postage prepaid to *hy-gain* with a personal check, cashiers check, or money order for \$8.00 covering postage and handling.
3. Under no circumstances is *hy-gain* liable for consequential damages to person or property by the use of any *hy-gain* products.
4. Out-of-warranty Service: *hy-gain* will repair any out-of-warranty product provided the unit is shipped prepaid. All repaired units will be shipped COD to the owner. Repair charges will be added to the COD fee unless other arrangements are made.
5. This warranty is given in lieu of any other warranty expressed or implied.
6. *hy-gain* reserves the right to make changes or improvements in design or manufacture without incurring any obligation to install such changes upon any of the products previously manufactured.
7. All *hy-gain* products to be serviced in-warranty or out-of-warranty should be addressed to ***hy-gain*, 308 Industrial Park Road, Starkville, Mississippi 39759, USA** and must be accompanied by a letter describing the problem in detail along with a copy of your dated proof-of-purchase.
8. This warranty gives you specific rights, and you may also have other rights which vary from state to state.