

④ Enlarged Section
3" 1'-0"

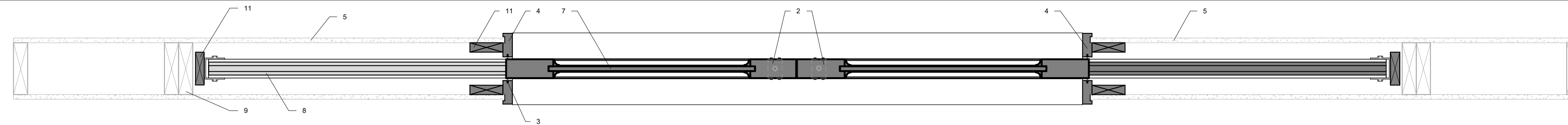

⑤ Pocket Door Assembly - Horizontal Section
1 1/2" 1'-0"

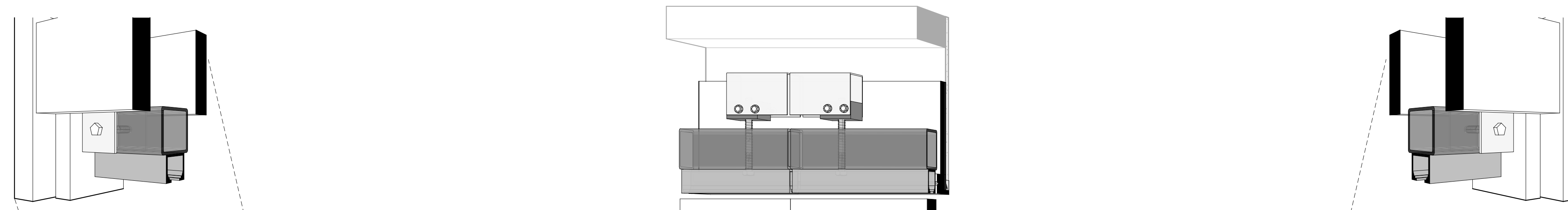

⑦ Enlarged Section 2
3" 1'-0"

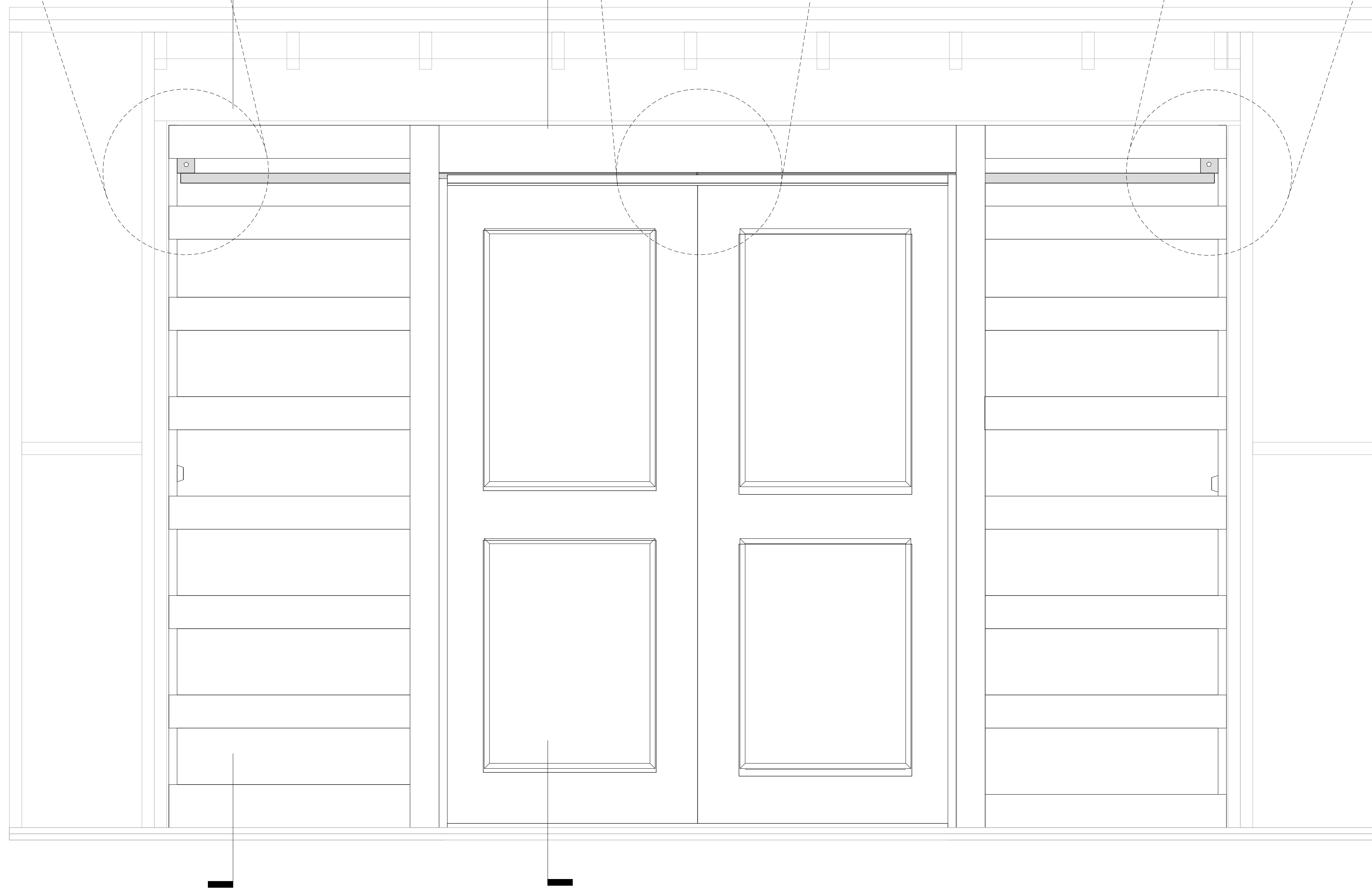

② Pocket Door Assembly Elevation
1 1/2" 1'-0"

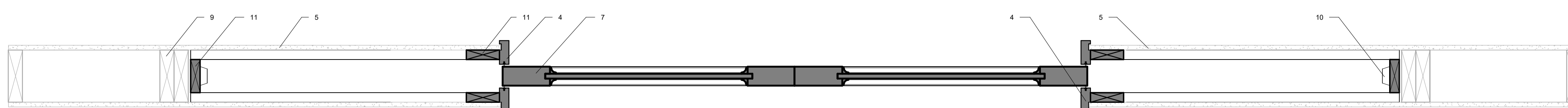

① Pocket Door Assembly - Horizontal Section
1 1/2" 1'-0"

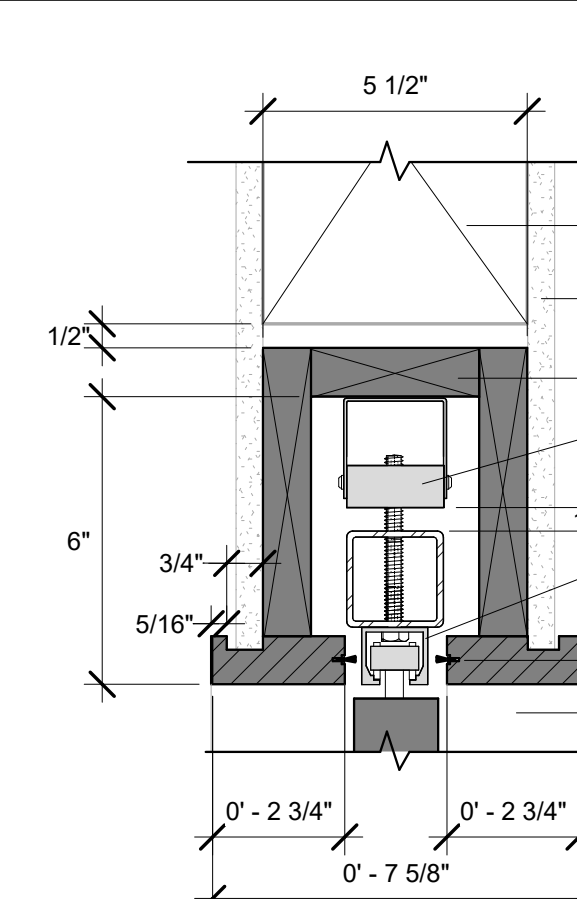

⑥ Section 2
1 1/2" 1'-0"

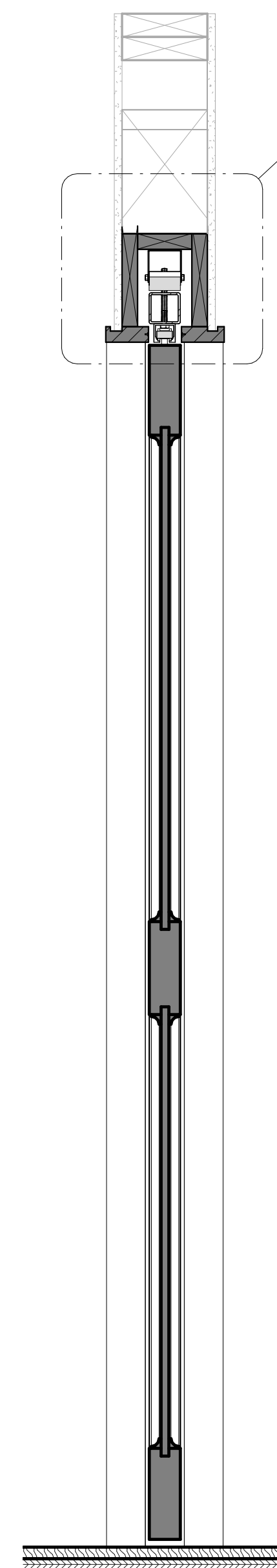

PPDS Assembly Notes - 2x6 Wall System

1. Header (by others)
2. PPDS bar. Bar to be adjusted to level position using vertical adjustment bolt. (Included)
3. Ultrafab Kerf Mounted Pile Weatherstripping. (Included)
4. Pre-manufactured pocket jamb. (Included)
5. Wall finish (by others)
6. Pre-manufactured pocket casing. (Included)
7. Door Leaf. 1-3/4" Door manufacturing (Included)
8. Hawa Junior 80/B trolley hanger assembly. Refer to manufacturers instructions (Included)
9. Structure (by others)
10. Bumper. (Included)
11. Pre-manufactured pocket frame. (Included)
12. PPDS Through Bolt Support Bracket mounted to vertical member of the pocket door frame.

Pre-Manufactured Pocket Door Frame
2" x 6" Wall Construction - Pocket Door Pair
petersonpocketdoorTM
SYSTEMS