



- TASTE THE DIFFERENCE -

MODEL 876B & 876BRH with Refrigerated Hopper

Fast, easy, portion-controlled, labor saving frozen cocktails from a machine that will last! This high-volume, counter-model cocktail freezer is pre-set for a high-quality, thicker consistency beverage, perfect for premixed cocktails like margaritas, daiquiris and spiked teas. The large visual product window provides excellent display and merchandising of fun beverage colors. Product viscosity, or thickness, can be manually adjusted to dial-in beverages to your serving requirements. The 876B can be water-cooled for large banks of machines in operations like daiquiri bars. There is an option for a refrigerated hopper (BRH) for serving real fruit or dairy mixes, like frozen cappuccinos! This model is perfect for bars, nightclubs, Mexican restaurants and taquerias.

MODEL 877HB & 877HBRH with Refrigerated Hopper

Fast, easy, portion-controlled, labor saving frozen cocktails from a machine that will last! This counter-model cocktail freezer produces the same high-quality cocktails as the 876B but at a size that's perfect for operations that do not require the volume. The pre-set thicker consistency is perfect for premixed drinks like margaritas, daiquiris and specialty cocktails. The large visual product window provides excellent display and merchandising of fun beverage colors. Product viscosity, or thickness, can be manually adjusted to dial-in beverages to your serving requirements. There is an option for a refrigerated hopper (HBRH) for serving fruit or dairy mixes, like frozen cappuccinos! This model is perfect for bars, nightclubs, Mexican restaurants and taquerias.

The Electro Freeze Advantage

- **Product Consistency Control** provides a smooth frozen product with tiny uniform ice crystals.
- **Minimal Maintenance**, simple to operate and easy to clean.
- **Add to Your Profits** with the sale of frozen beverages producing large profit margins.
- **Experience Tells** Electro Freeze has been manufacturing quality frozen treat machines since 1929. Superior engineering, product innovations, sturdy construction, quality craftsmanship and dependable performance are Electro Freeze hallmarks.
- **Superior Service Support** backed by a worldwide distributor network.

COCKTAIL FREEZERS

MODEL 876B
MODEL 876BRH



MODEL 877HB
MODEL 877HBRH



876B

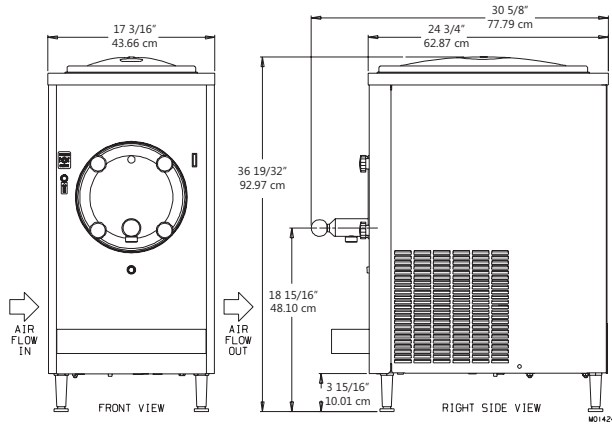

877HB

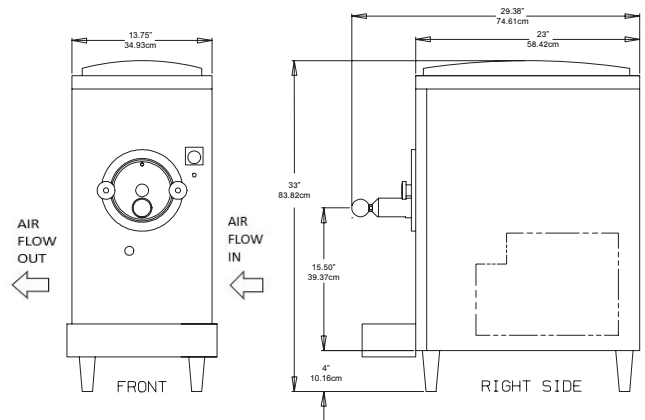

MODEL 876B & 877HB SPECIFICATIONS

Due to continual product improvements all specifications are subject to change without notice.

Weights	876B		877HB	
	lbs.	kgs.	lbs.	kgs.
Net	255	116	210	95
Crated	274	124	245	111
	cu.ft.	cu.m.	cu.ft.	cu.m.
Volume	20.53	0.58	20.53	0.58
Dimensions	in.	cm	in.	cm
Width	17-3/16	43.66	13.75	34.93
Depth	24-3/4	62.87	23	58.42
Height	36-19/32	92.97	33	83.82

Electrical	Maximum Fuse Size	NEMA Plug Type
115/60/1 Air	20A	5-20P

Electrical characteristics other than above available on request from factory or local distributor. Check nameplate for exact electrical data.

Bidding Spec

Electrical: Volt _____ Hz _____ Ph _____

Cooling: _____ Neutral _____ Yes _____ No

Options: _____

Electrical

One dedicated electrical connection is required. 60 Hertz units connect to a standard NEMA 5-20P receptacle. See electrical chart for the proper requirement. Consult your local electrical codes for cord and receptacle specifications.

Beater Motor

One, 1/4 hp.

Refrigeration Systems

One, 5,700 Btuh.
Btuh may vary depending on compressor used.

Air Cooled

876- 3" (7.62 cm) air space required on both sides and the rear panel for proper air circulation.

877HB-12" (30.5 cm) air space required on both sides and 6" (15.2 cm) air space required on rear panel for proper air circulation and be open on the top.

Mix Hopper Capacity: 20 quarts (18.93 liters)

Freezing Cylinder Capacity: 876-14.6 quarts (13.82 liters)

877HB- 7.6 quarts (7.1 liters)

Certified and/or listed by:



*UL listed and listed by Underwriters Laboratories under Canadian National Standard C22.2 No. 120-13



Electro Freeze div. of H.C. Duke & Son, LLC

2116-8th Avenue, East Moline, Illinois 61244 USA Phone
(309) 755-4553 • (800) 755-4545
FAX (309) 755-9858
E-mail: sales@electrofreeze.com • www.electrofreeze.com

Authorized Distributor