



SMARTSHIFT

robotics

ROBOTIC TOOL CHANGE SYSTEM

Collaborative · Industrial · Delta · Scara · Linear



 SMARTSHIFT robotics manual and automatic tools are universal units that are compatible with most robot manufacturers on the market.

The standard connection is based on the Ø50 mm, 4 pcs M6. Center Ø31.5 mm flange, but the units are adaptable to different tool flange mountings. SMARTSHIFT robotics has on stock made scale-ups, and scale-downs to fit different manufacturers and have already a portfolio of Adapters/-Fittings to mount the SMARTSHIFT robotics tools on to your preferred robot or cobot.

See list of pre made Adapters/Fittings. If you can not see your model type or brand in the list, contact SMARTSHIFT robotics and we will manufacture the Adapter/Fitting needed.

All robots and cobots within the range of 0-50 kg Payload are compatible with the SMARTSHIFT robotics manual and automatic tools.

COMPATIBLE WITH:

Abb - Acutronic - Aubo - Automata - Bosch - Carbon - Comau - Denso - Dlr - Dobot - Doosan - Elephant Robotics - Elibot - Esi - F&P Personal Robotics - Fanuc - Festo - Flexiv - Franka Emika - Han's Robot - Hanwha - Hitbot - Hit Robot Group - Hyunday Robotics - Inovo Robotics - Isybot - Jaka - Kassow Robots - Kawada Industries Inc. - Kawasaki Robotics - Kinetic Systems - Kinova - Kuka - Life Robotics - Mabi - Megarobo - Mip Robotics - Modbot - Mrk-Systeme - Nachi - Neuromeke - Niryo - Omron Techman - Pilz - Precise Automation - Productive Robotics - Rainbow Robotics - Rethink Robotics - Robut Technology - Rozum Robotics - Siasun - St Robotics - Staubli - Svaya Robotics - Tokyo Robotics - Ufactory - Universal Robots - Yaskawa - Yuanda

With the Smartshift Robotics tool system you can give your preferred Robot a «tool belt», this way by adding any tool of choice, creating a fully operational manufacturing line within the production using only one Robot.

The Smartshift Robotics system cuts down cost of installation, adds value to every Robot and reduces the ROI of every Robot cell.



FROM BUIND AS TO SMARTSHIFT-ROBOTICS

Smartshift-robotics was established in 2018 by Kjell Buind in a remote area a short drive outside the main capital of Norway, Oslo.

With over 40 years of experience in making automation solutions for the manufacturing industry, the craftsmanship. Precision and quality of the Smartshift-robotics product has taken its rightful place in the robotics industry across the globe in a short time.

Smartshift-robotics solutions that now covers more than the range of mounting, welding, palletizing and polishing has set its goal on being the main supplier to manufacturers across the globe, empowering all sizes of industry to create production lines, within the production facility's, often using already existing equipment.



ASSEMBLY
Screw and nut driving, inserting, mounting and positioning.

PALLETIZING / PACKING
Sorting, packaging, labelling and palletizing.

MACHINE TENDING
CNC, injection moulding, cutting, metal casting, press and processes.

MATERIAL FINISHING
Painting, polishing, sanding, drilling and milling.

QUALITY TESTING
Testing, inspection and measuring.

WELDING
Laser, ultrasonic, soldering and spot welding.

Machine tending / CNC Park



Smartshift manufacture all its Tools at our HQ location in Hønefoss Norway.

Our machine park consists of a variety from milling, cutting and CNC machinery. With a mix of signature machinery and state of the art CNC machines, Smartshift is capable with solving high complex solutions needed to produce the range of Tool in the Smartshift product family.



Transport and Freight

Smartshift-robotics has arrangements with International and Domestic freight and transport companies that provides an easy, fast and secure delivery of your ordered goods.

Transport of goods will follow guidelines and standards of the partners signed by Smartshift-robotics, using DAP Incoterms® 2022.

OEM / CUSTOM MADE

Smartshifts unique technology has in short time been embraced by the Industrial market. This simple but perfected patented design of the Smartshift Tools has already proven to be a strong partner for the OEM and Custom fitted needs at several of Smartshifts partners. Smartshift has therefor taken a position in the market of being a development partner for several Tool and machine manufacturers.

As a support for future developments, helping your Tool range to potentially stepping into the Robotics sector and empowering the statement «Robot as a Tool» and «Miniature manufacturing lines», Smartshift is always open for new partnerships and market potential.

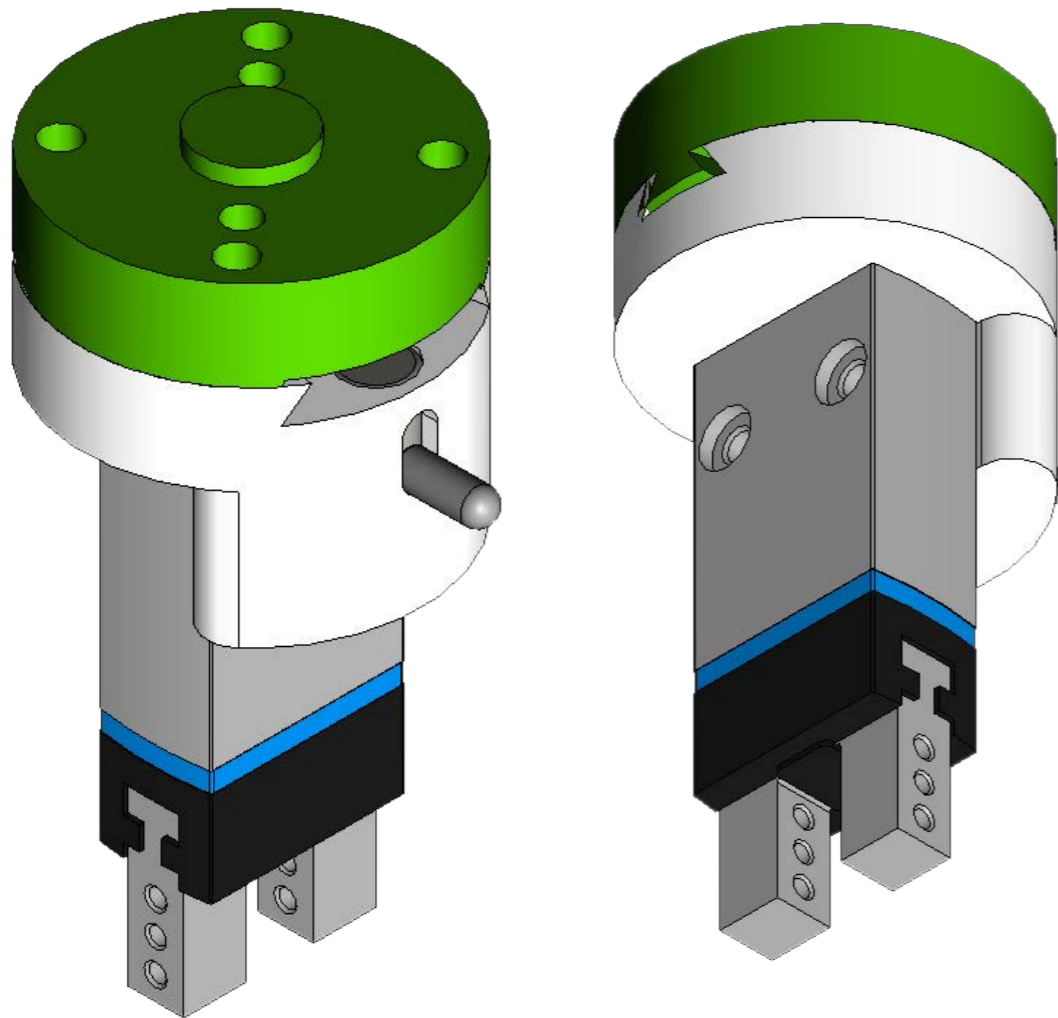

COLLABORATIVE, INDUSTRIAL, DELTA, SCARA AND LINEARE ROBOTIC APPLICATIONS

Over the year's robots have evolved into fast and agile machines that can work autonomously. Tooling has also evolved adapting to the ever-changing need the manufactures have. The interconnection is therefore a vital element in adaption of robots for a wide range of applications.

Our innovative tool changer helps manufactures to gain the full advantages of using robot including ease of use, cost-effectiveness and productions efficiency.

SMARTSHIFT patented design and functionality make our system adaptable for all applications. You can use SMARTSHIFT for assembling, welding, and sorting, packaging, labelling and really everything you can use a robot for. A truly collaborative solution for all applications and regardless of which robots or tools you are using.

When using the SMARTSHIFT system you can move from one operation to another quickly and easily, which increase the applications versatility, efficiency and productivity.

Mechanical function



CONSISTS OF:

- Master
- Tool Holder

FUNCTION:

Manual or Automatic Tool Change where there is no need for air, vacuum or Electric EOAT.

Mechanical Electric



CONSISTS OF:

- Master with EI.
- Tool Holder with EI.

FUNCTION:

Manual or Automatic Tool Change where there is need for Electric EOAT, or a combination of Mechanical and Electric EOAT. Master with Electric can also be used with a pure Mechanical Tool Holder.

Mechanical Pneumatic



CONSISTS OF:

- Master with tubings
- Tool Holder

FUNCTION:

Manual or Automatic Tool Change where there is need of air or vacuum supplied EOAT, or a combination of Mechanical and Pneumatic EOAT. Pneumatic use without Manifold passes air or vacuum directly to the EOAT. Master with tubings can also be used with a pure Mechanical Tool Holder.

Mechanical Pneumatic



CONSISTS OF:

- Master with tubings
- Tool Holder
- Manifold

FUNCTION:

Manual or Automatic Tool Change where there is need of a air or vacuum supplied EOAT, or a combination of Mechanical and Pneumatic EOAT. The Manifold directs the Pneumatic out on the sides and frees the mounting surface of the EOAT. Master with tubings can also be used with a pure Mechanical Tool Holder.

Mechanical Electric Pneumatic



CONSISTS OF:

- Master with Electric and tubings
- Tool Holder Electric

FUNCTION:

Manual or Automatic Tool Change where there is need of a combination of Electric and air or vacuum supplied EOAT, or a combination of Mechanical, Electric and Pneumatic EOAT. Pneumatic use without Manifold passes air or vacuum directly to the EOAT. Master with Electric can also be used with a Pneumatic and pure Mechanical Tool Holder.

Mechanical Electric Pneumatic



CONSISTS OF:

- Master with Electric and tubings
- Tool Holder Electric
- Manifold

FUNCTION:

Manual or Automatic Tool Change where there is need of a combination of Electric and air or vacuum supplied EOAT, or a combination of Mechanical, Electric and Pneumatic EOAT. The Manifold directs the Pneumatic out on the sides and frees the mounting surface of the EOAT. Master with Electric can also be used with a Pneumatic or pure Mechanical Tool Holder.



AUTOMATIC PNEUMATIC TOOL CHANGER

The Pneumatic Tool Changer is a good introduction to the SMARTSHIFT products, as it permits all the possible connections. The automatic pneumatic tool changer is ready for easy mounting and tool changing in all applications, Where you need pneumatic connection.

The automatic pneumatic tool changer is the most popular SMARTSHIFT set. The tool changer provides automatic mechanical and pneumatic connection. With the automatic pneumatic tool changer, it is easy to change tools autonomous and you have the option to upgrade to electrical connection. To upgrade for an electric solution, you have to purchase SMARTSHIFT cable electric connector M8. The automatic pneumatic tool changer consists of one robot master, two tool holders and two tool pockets.



ROBOT MASTER



Robot Master

PRODUCT FEATURES AND SPECIFICATIONS

- **Fast**
Fast Works at high speed and precision
- **Accurate**
With the range of five hundredth of a millimeter in all directions and angles
- **Ease of use**
Easy to deploy and redeploy with smart mechanical design
- **Installation**
Easy installation and hereby high security
- **Handling payload**
50 kg
- **Connection**
Pneumatic 2xG 1/8"
- **Weight total**
150g

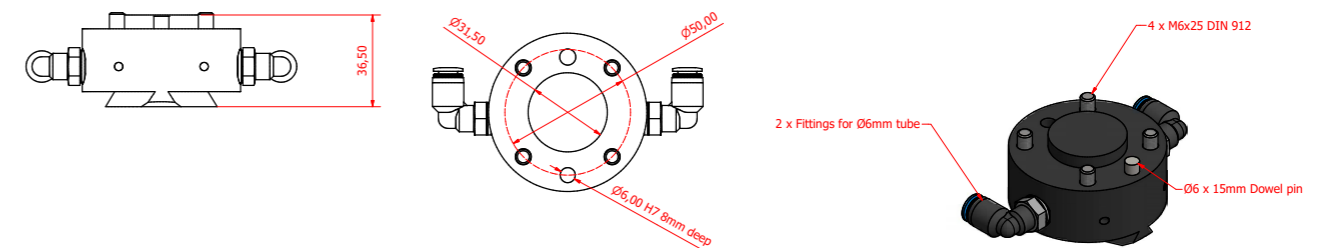

ITEM NO.
1000

Robot Master electric

PRODUCT FEATURES AND SPECIFICATIONS

- **Fast**
Fast Works at high speed and precision
- **Accurate**
With the range of five hundredth of a millimeter in all directions and angles
- **Ease of use**
Easy to deploy and redeploy with smart mechanical design
- **Installation**
Easy installation and hereby high security
- **Handling payload**
50 kg
- **Connection**
Pneumatic 2xG 1/8"
- **Weight total**
180g



1100 / Female
1101 / Male

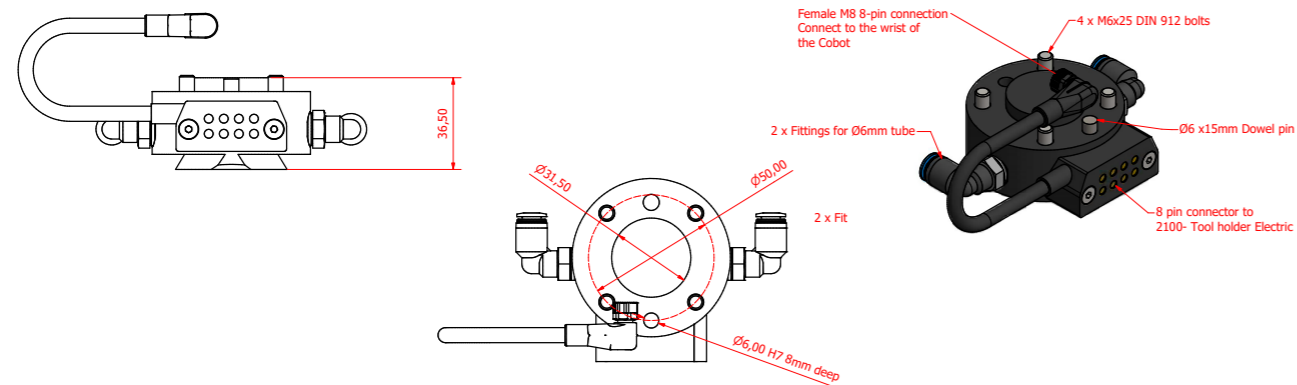

 **ITEM NO.**
1100/Female · 1101/Male

Robot Master GEN III electric connector Industrial

PRODUCT FEATURES AND SPECIFICATIONS

- **Pneumatic 2xG 1/8"**
- **Electric M8 8 pin 24 V 1 AMP**
- **Weight total**
35g
- **Custom connectors**
On demand, Smartshift-robotics Custom installs and fit connectors To fit your Robot or Cobot type. Smartshift tools connects to all Robots, Industrial and Collaborative.



 **ITEM NO.**
1103

Robot Master GEN III

PRODUCT FEATURES AND SPECIFICATIONS

- **Fast**
 - Works at high speed with high stiffness
- **Accurate**
 - With the range of five hundredth of a millimeter in all directions and angles
- **Ease of use**
 - Easy to deploy and redeploy with smart mechanical design
 - Easy installation and hereby high security
- **Handling payload**
 - 50 kg
- **Connection**
 - Pneumatic 2xG 1/8"
- **Weight total**
 - 150g



ITEM NO.
1120

Robot Master GEN III Electric

1121 / Female
1122 / Male

PRODUCT FEATURES AND SPECIFICATIONS

- **Fast**
 - Works at high speed with high stiffness
- **Accurate**
 - With the range of five hundredth of a millimeter in all directions and angles
- **Ease of use**
 - Easy to deploy and redeploy with smart mechanical design
 - Easy installation and hereby high security
- **Handling payload**
 - 50 kg
- **Connection**
 - Pneumatic 2xG 1/8"
 - Electric M8 8 pin 24 V 1 AMP
- **Weight total**
 - 180g

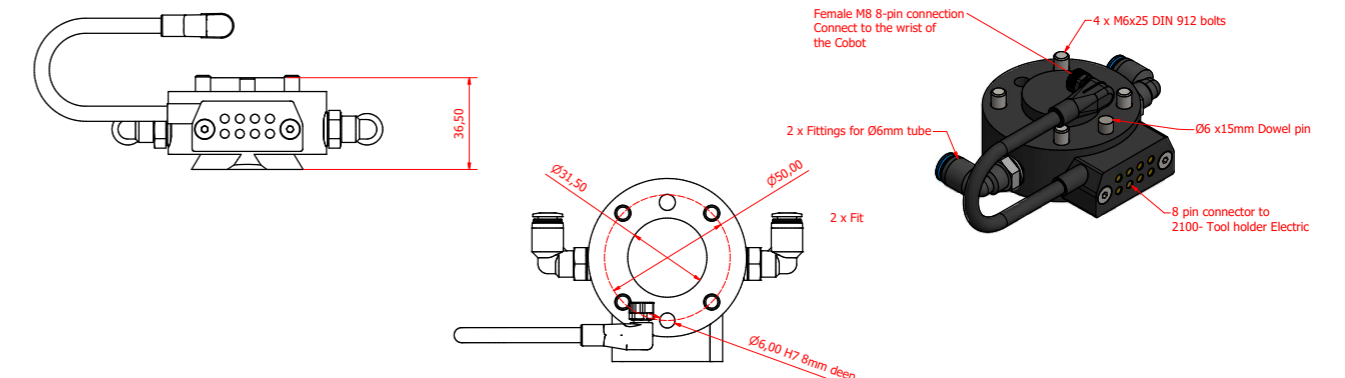

ITEM NO.
1121/Female · 1122/Male

Robot electric M8 connectors

1110 / Female
1111 / Male

PRODUCT FEATURES AND SPECIFICATIONS

- **Pneumatic 2xG 1/8"**
- **Electric M8 8 pin 24 V 1 AMP**
- **Weight total**
35g
- **Custom connectors**
On demand, Smartshift-robotics Custom installs and fit connectors To fit your Robot or Cobot type. Smartshift tools connects to all Robots, Industrial and Collaborative.

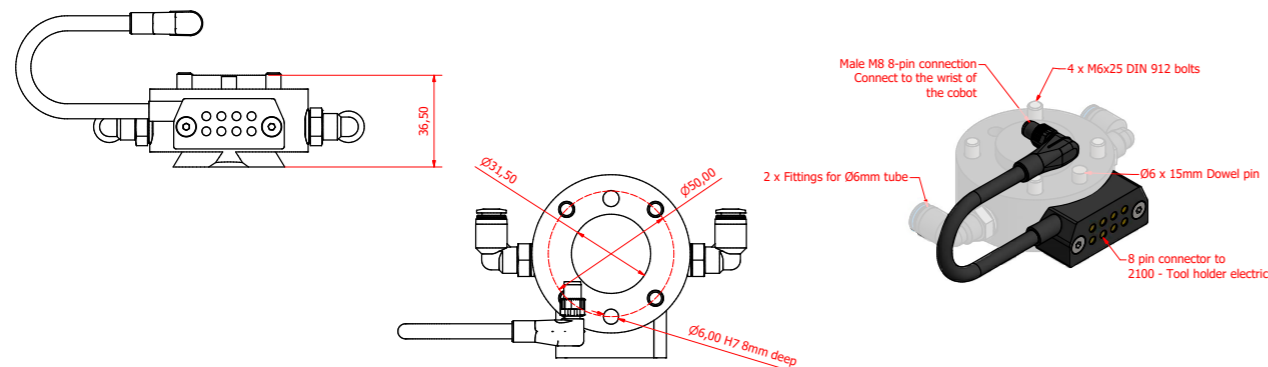
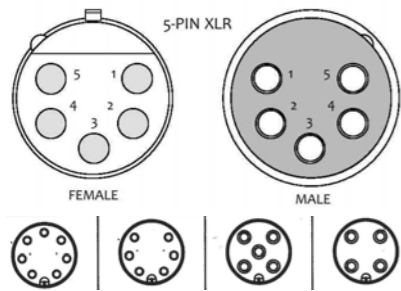

ITEM NO.
1110/Female · 1111/Male

Robot electric connector Industrial

PRODUCT FEATURES AND SPECIFICATIONS

- **Fast**
Works at high speed with high stiffness
- **Accurate**
With the range of five hundredth of a millimeter in all directions and angles
- **Ease of use**
Easy to deploy and redeploy with smart mechanical design
- Easy installation and hereby high security
- **Handling payload**
50 kg
- **Connection**
Pneumatic 2xG 1/8"
Electric M8 8 pin 24 V 1 AMP
- **Weight total**
180g

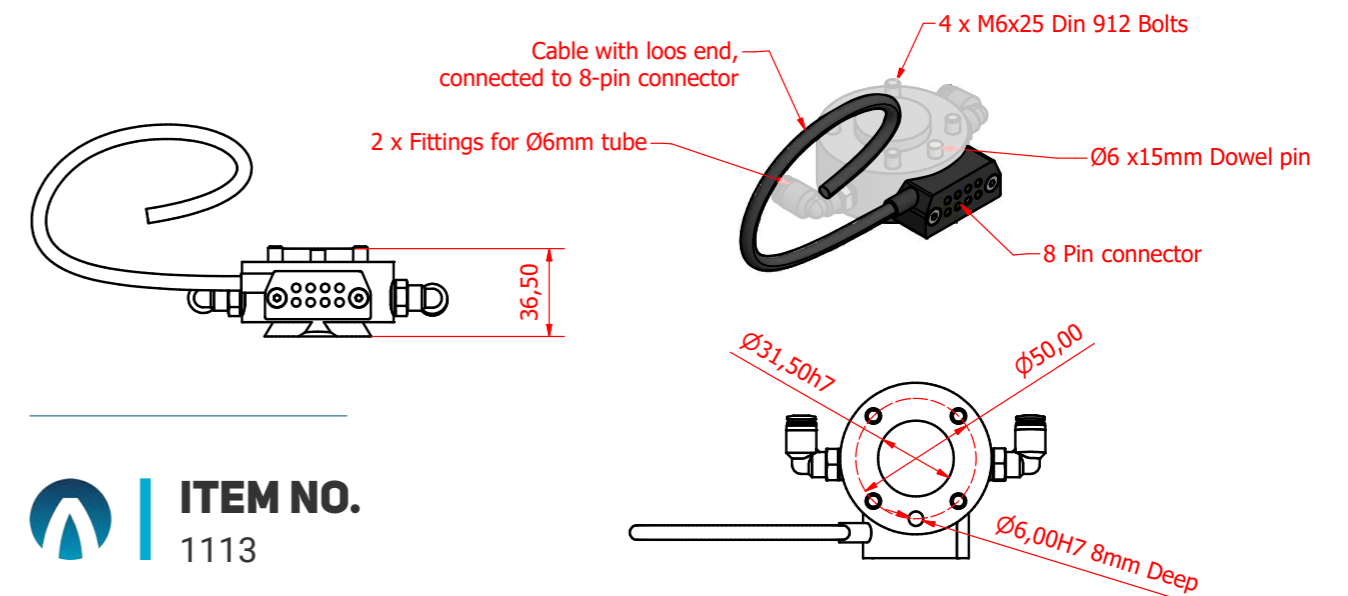

ITEM NO.
1113

Robot electric M8 straight connector

1115 / Female
1114 / Male

PRODUCT FEATURES AND SPECIFICATIONS

- **Pneumatic 2xG 1/8"**
- **Electric M8 8 pin 24 V 1 AMP**
- **Weight total**
35g
- **Custom connectors**
On demand, Smartshift-robotics
Custom installs and fit connectors
To fit your Robot or Cobot type.
Smartshift tools connects to all
Robots, Industrial and Collaborative.

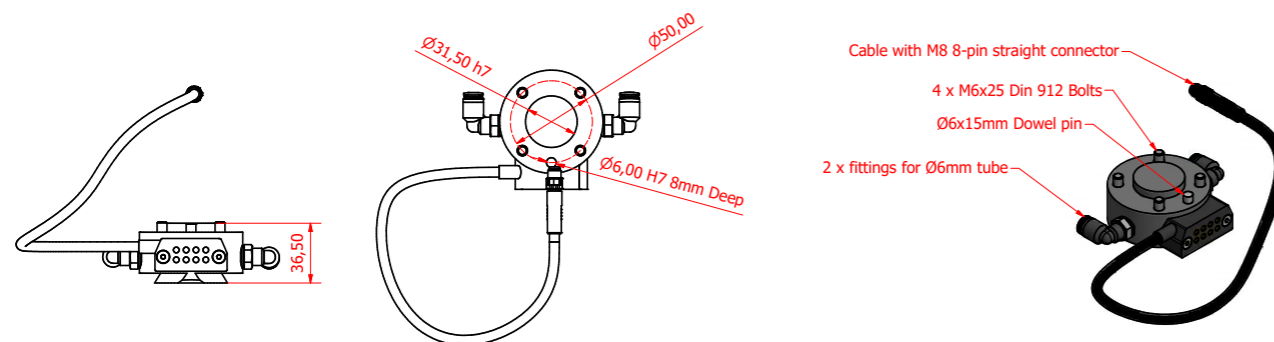
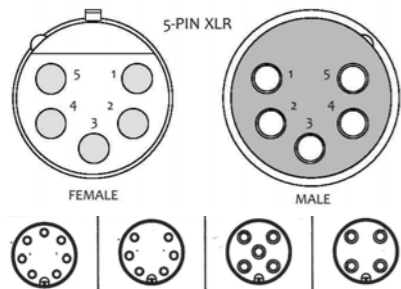

ITEM NO.
MALE 1114 / FEMALE 1115

Robot master light Manuel shifter

PRODUCT FEATURES AND SPECIFICATIONS

- **Manuel**
Easy change system,
with secure locking
mechanism
- **Accurate**
With the range of five hundredth
of a millimeter in all directions
and angles
- **Ease of use**
• Easy to deploy and redeploy
with smart mechanical design
- **Handling payload**
20 kg
- **Weight total**
180g

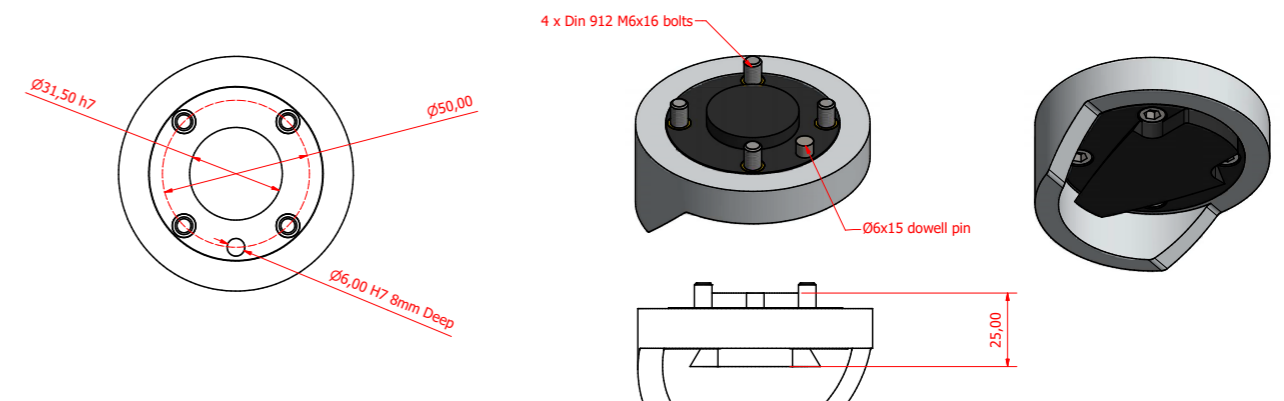

ITEM NO.
1500

TOOL HOLDER

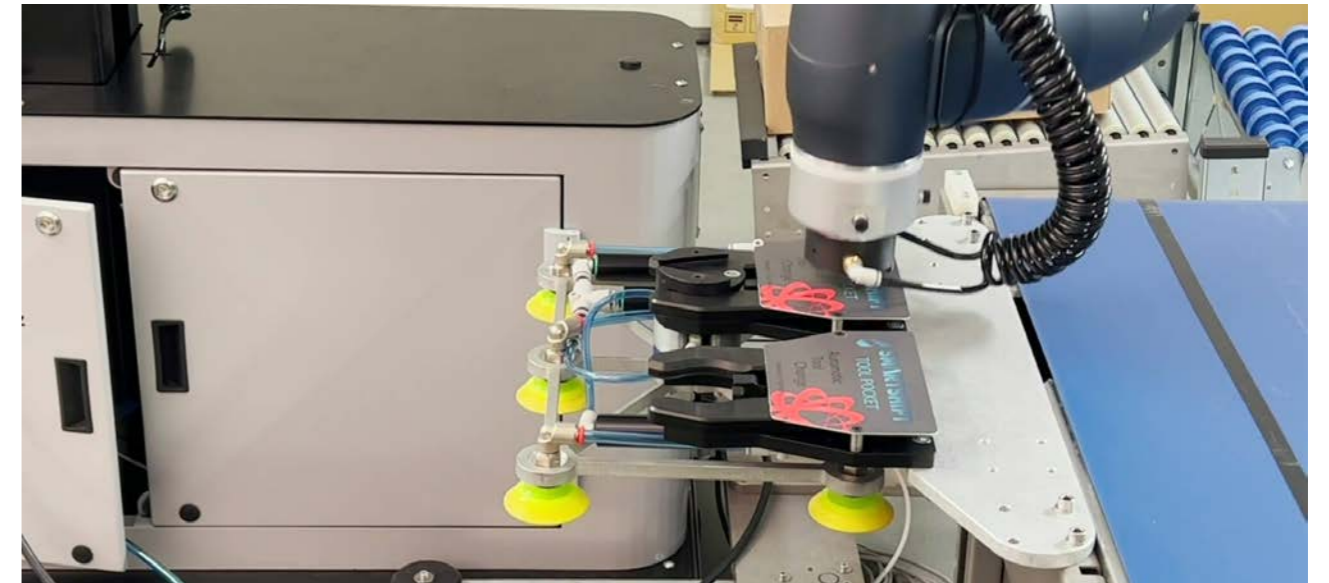
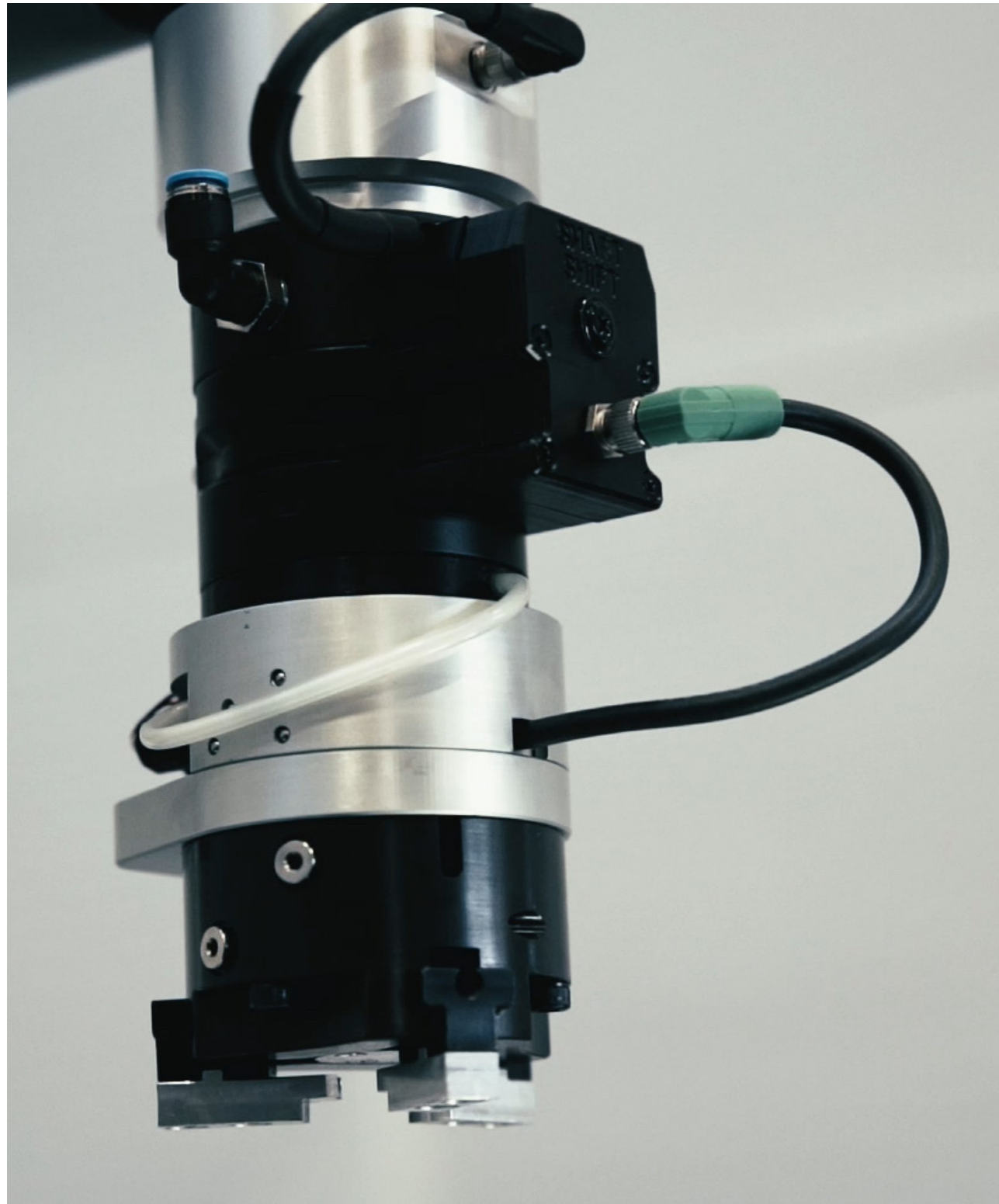

Tool holder

PRODUCT FEATURES AND SPECIFICATIONS

- **Fast**
Works at high speed and precision
- **Accurate**
With the range of five hundredth of a millimeter in all directions and angles
- **Ease of use**
Easy to deploy and redeploy with smart mechanical design
- **Installation**
Easy installation and hereby high security
- **Handling payload**
50 kg
- **Connection**
Pneumatic 2xG 1/8"
- **Weight total**
255g

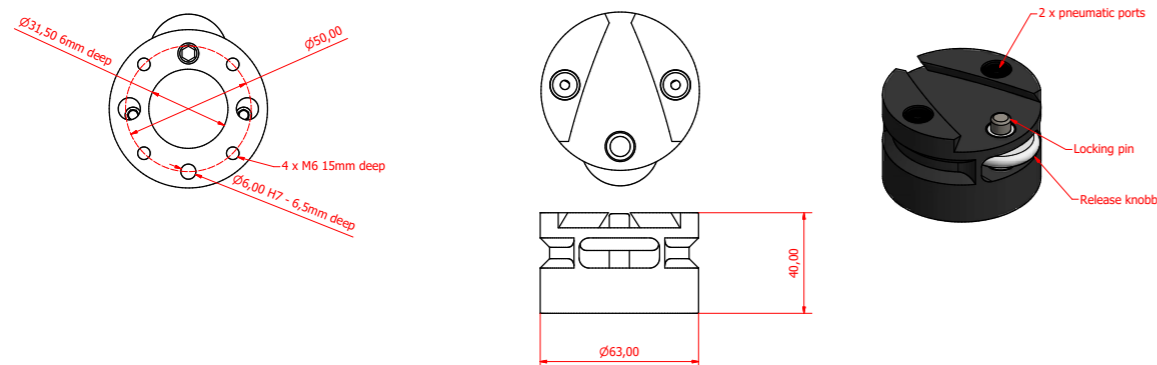

Tool holder GEN III

PRODUCT FEATURES AND SPECIFICATIONS

- **Fast**
Works at high speed and precision
- **Accurate**
With the range of five hundredth of a millimeter in all directions and angles
- **Ease of use**
Easy to deploy and redeploy with smart mechanical design
- **Installation**
Easy installation and hereby high security
- **Handling payload**
50 kg
- **Connection**
Pneumatic 2xG 1/8"
- **Weight total**
255g

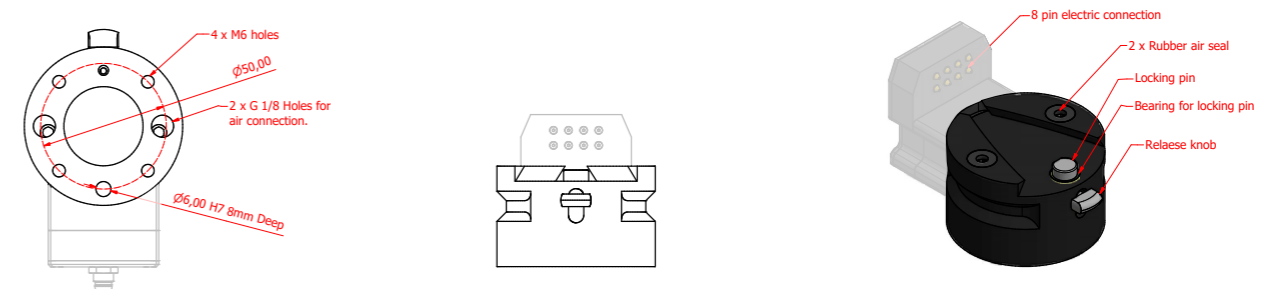

Tool holder Electric M8 connectors

2101 / Female
2100 / Male

PRODUCT FEATURES AND SPECIFICATIONS

- **Fast**
Works at high speed and precision
- **Accurate**
With the range of five hundredth of a millimeter in all directions and angles
- **Ease of use**
Easy to deploy and redeploy with smart mechanical design
- **Installation**
Easy installation and hereby high security
- **Handling payload**
50 kg
- **Connection**
Pneumatic 2xG 1/8"
- **Weight total**
255g

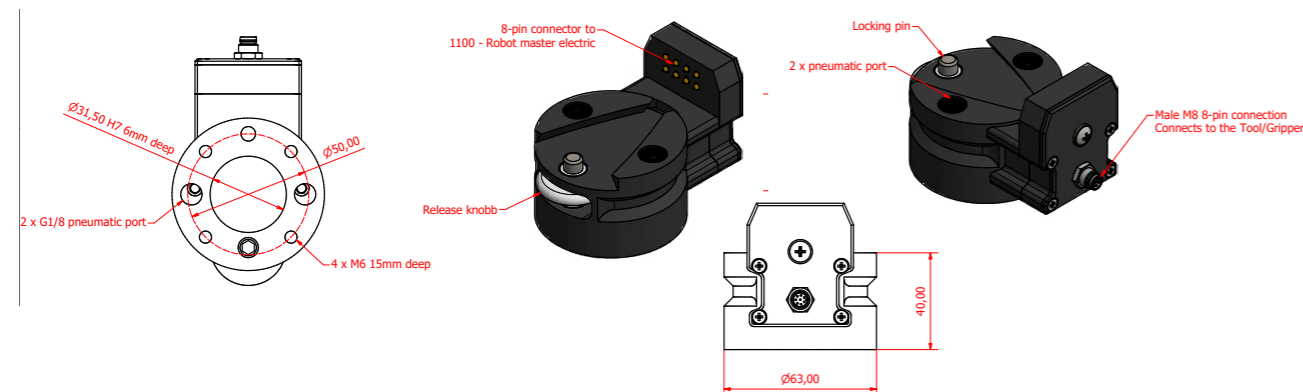

ITEM NO.
2101/Female · 2100/Male

Tool holder GEN III Electric M8 connectors

2122 / Female
2121 / Male

PRODUCT FEATURES AND SPECIFICATIONS

- **Fast**
Works at high speed and precision
- **Accurate**
With the range of five hundredth of a millimeter in all directions and angles
- **Ease of use**
Easy to deploy and redeploy with smart mechanical design
- **Installation**
Easy installation and hereby high security
- **Handling payload**
50 kg
- **Connection**
Pneumatic 2xG 1/8"
- **Weight total**
255g

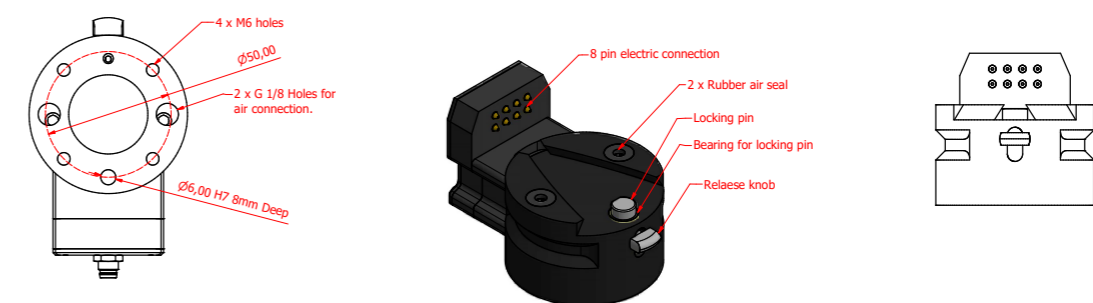

ITEM NO.
2122/Female · 2121/Male

Tool Electric M8 connectors

PRODUCT FEATURES AND SPECIFICATIONS

- **M8 Connector**
Pneumatic 2xG 1/8"
- **Weight total**
55g
- **Custom connectors**
On demand, Smartshift-robotics Custom installs and fit connectors to fit your Robot or Cobot type. Smartshift tools connects to all Robots, Industrial and Collaborative.

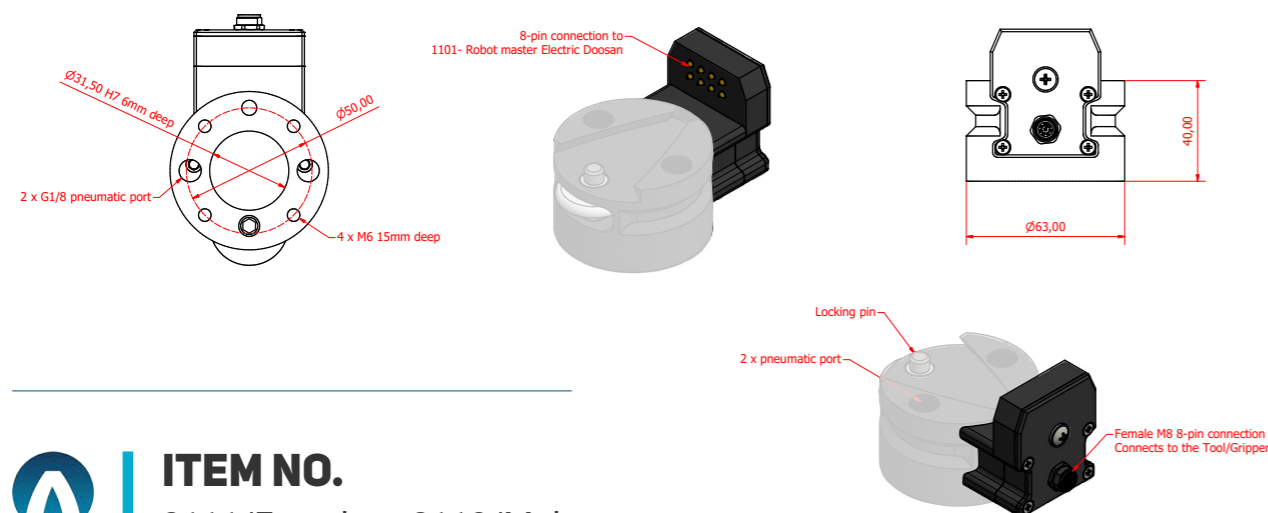
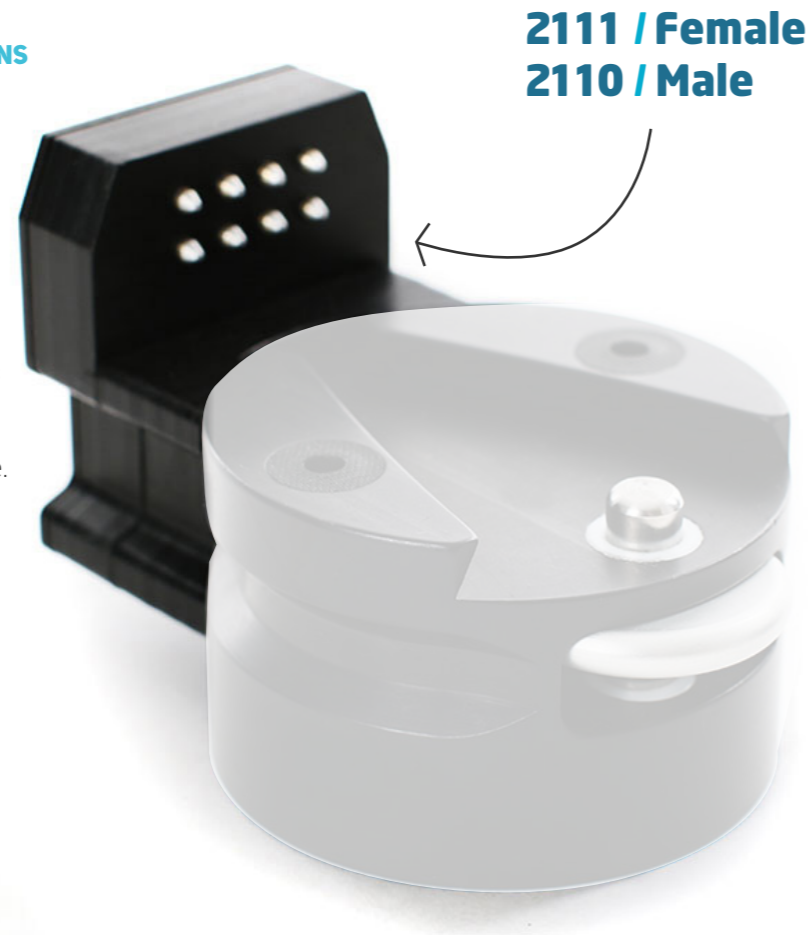

 **ITEM NO.**
2111/Female · 2110/Male

Tool holder light Manuel shifter

PRODUCT FEATURES AND SPECIFICATIONS

- **Manuel**
Easy change system, with secure locking mechanism
- **Accurate**
With the range of five hundredth of a millimeter in all directions and angles
- **Ease of use**
Easy to deploy and redeploy with smart mechanical design
- **Handling payload**
20 kg
- **Weight total**
120g

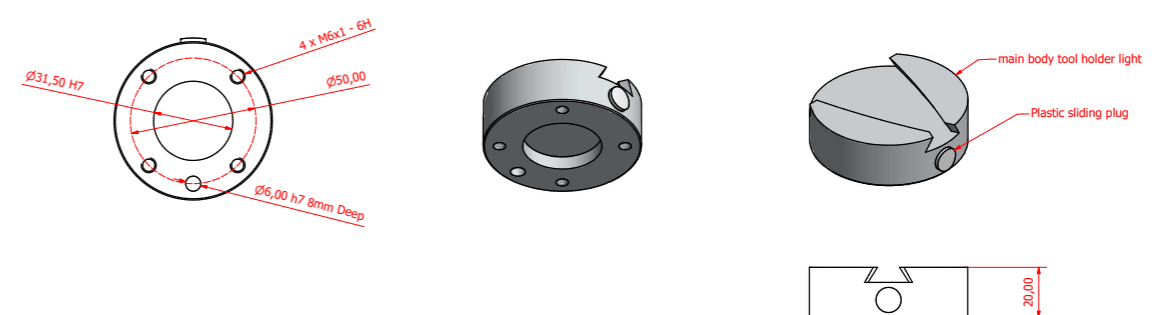

 **ITEM NO.**
2500

AUTOMATIC PNEUMATIC TOOL CHANGER

For applications where tool changing is a necessary for changing applications, the automatic tool changer is a good option. This tool changer enables mechanical, pneumatic and optionally also electric connection. It includes tool pockets with the possibility to exchange tools seamlessly and work on multiple tasks without stopping.

The automatic pneumatic tool changer is the most popular SMARTSHIFT set. The tool changer provides automatic mechanical and pneumatic connection. With the automatic pneumatic tool changer, it is easy to change tools autonomously and you have the option to upgrade to electrical connection. To upgrade for an electric solution, you have to purchase SMARTSHIFT cable electric connector M8. The automatic pneumatic tool changer consists of one robot master, two tool holders and two tool pockets.

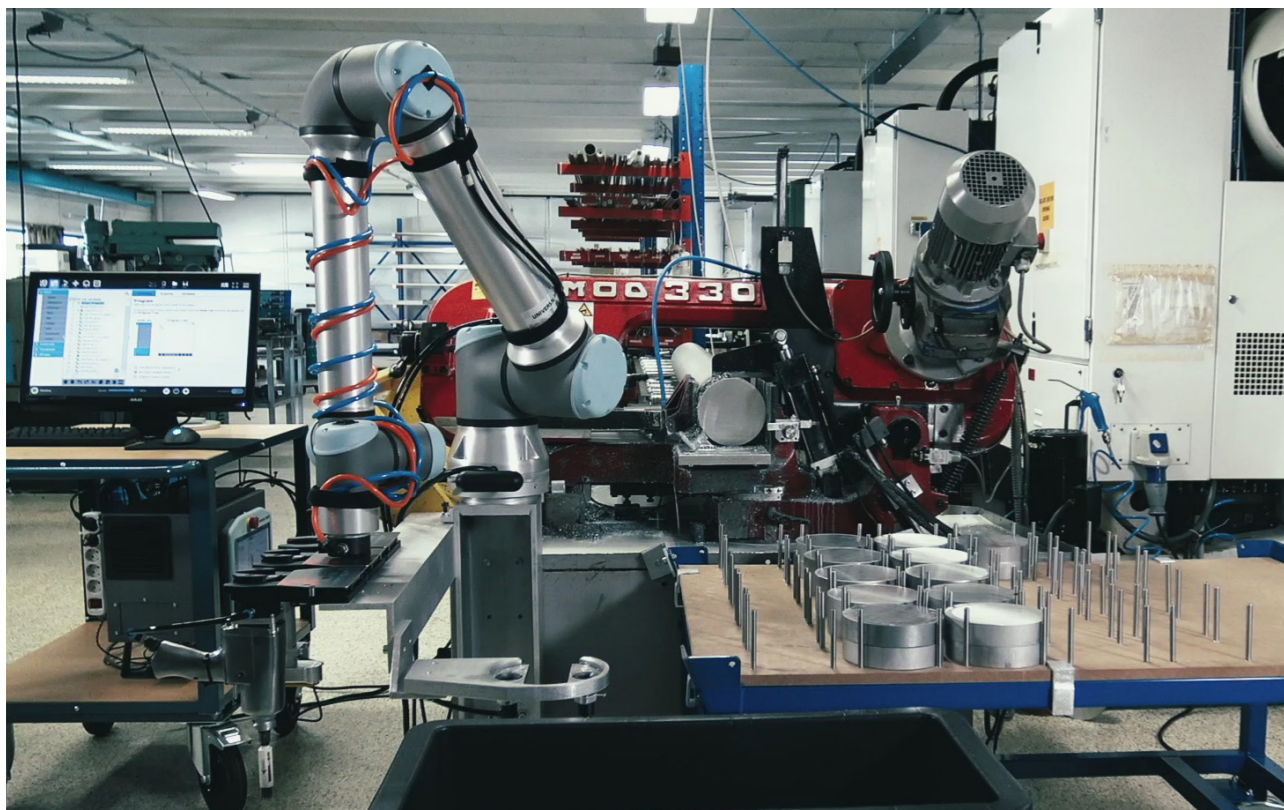

Tool Pocket

PRODUCT FEATURES AND SPECIFICATIONS

- **Fast**
Works at high speed and precision
- **Flexible and precise**
Connecting the robot tools with the range of five hundredth of a millimeter precision. The flexible entry of the pocket gives the operator 100% accuracy on the tool connection, even with marginal entry offset.
- **Ease of use**
Easy to deploy and redeploy with smart mechanical design.
- **Installation**
Easy installation and hereby high security
- **Handling payload**
5 kg
- **Connection**
Pneumatic 2xG 1/8"
Electric M8 8 pin 24 V 1 AMP
- **Weight total**
785g

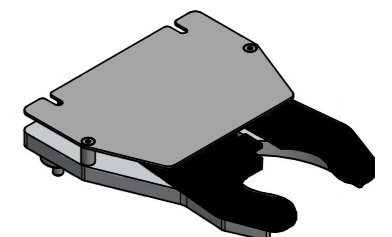
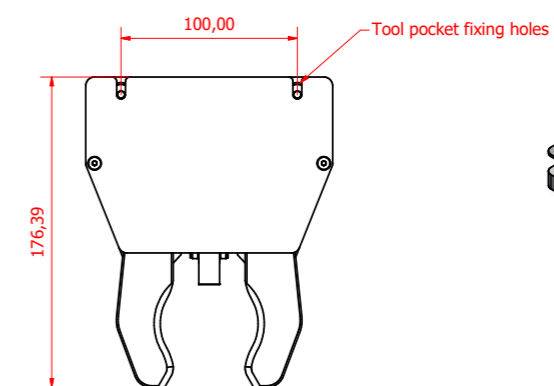
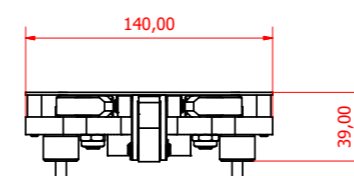

ITEM NO.
3000

LOCK PIN

The new GEN III Smartshift Robotics Tool Changer has an upgraded locking pin system that is created to give more precision and stability than its former GEN II version.

Although the GEN II is a robust system with an accuracy of 0.05 mm, equal to the general Collaborative robot, the GEN III with its new lock technology tightens even better and will over time of use continue to function without any default. The angled shape on the locking pin slides in to position much like a wedge and will continue to tighten even with usage over time.

The Smartshift units have been tested at 1.6 million shifts and to secure any wearing of the POM, the wedge function is intended to continue its lock strength in a long-lasting use scenario.

Freestanding the Lock pin will be in full suspension on the Tool Holder, but when mounted together the Lock pin will have a lower position due to the wedge function, unlike the GEN II cylinder-shaped Lock pin.

By adding strength to our tools, we also add strength to the end user and the verity of Robot applications on the market.

When THE units
are not combined:



When the units
are combined:



ROBOTBASE



ROBOTBASE SET /Custom Fit

For multiple workstations and one robot, the robotbase set is a cost-effective solution. You can move your robot to other workstations quick and easy to be used in already pre-programmed Robot applications.

For example, the robot can make a welding task the first hours of the day and the next hours stands at the assemble line. With this solution the robot can do multiple tasks in different workstations all over the production.

Smartshift Robot Base Set can be custom made to fit your Robot of choice. With the Smartshift Robot Base Set adaptor system, this relocater tool will be modified for any Brand of Robot, both Colleborative and smaller Industrial.



Master Base

PRODUCT FEATURES AND SPECIFICATIONS

- **Fast and accurate movement**
Re-deploys in seconds
- **Accurate**
Re-positioning with the range of five hundredth of a millimeter.
- **Easy to use**
Quick release with accurate locking system.
- **Custom Base**
On request, Smartshift-robotics Custom manufacture bases to fit your Robot or Cobot type. Smartshift Base connects to all Robots, Industrial and Collaborative.



BSR 00147 4000
MASTER BASE UR3

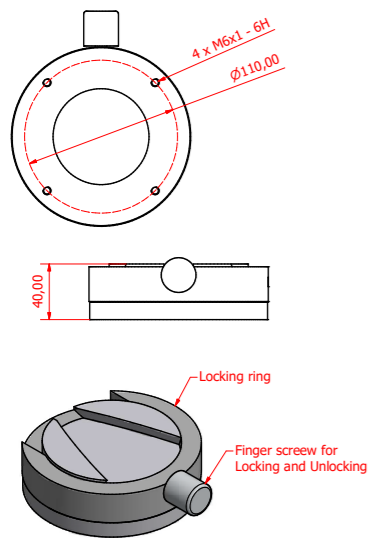

BSR 00148 4001
MASTER BASE UR5

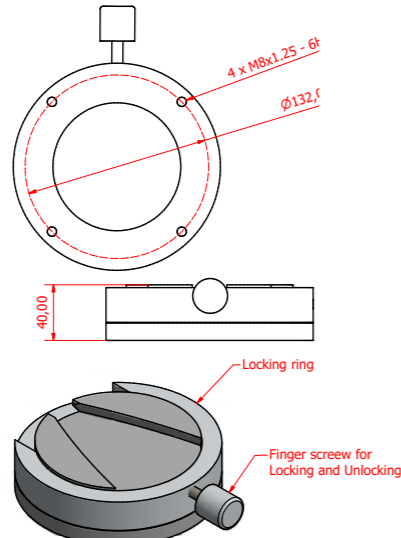

BSR 00149 4002
MASTER BASE UR10 16

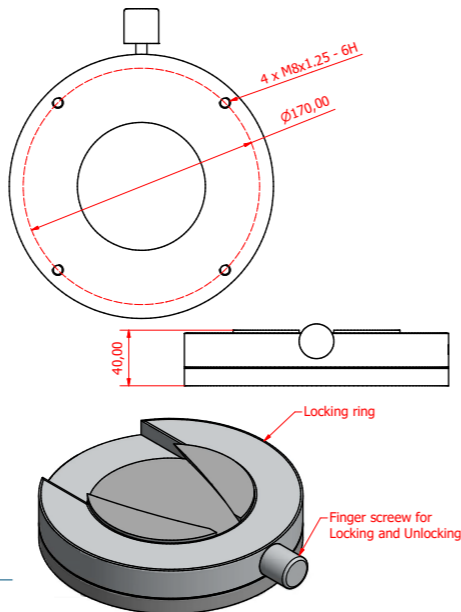

ITEM NO.
4000 / 4001 / 4002 / 4003 / 4004 / 4005 CUSTOM

Baseplate

PRODUCT FEATURES AND SPECIFICATIONS

- **Fast and accurate movement**
Re-deploys in seconds
- **Accurate**
Re-positioning with the range of five hundredth of a millimeter.
- **Easy to use**
Quick release with accurate locking system.
- **Custom Base**
On request, Smartshift-robotics Custom manufacture bases to fit your Robot or Cobot type. Smartshift Base connects to all Robots, Industrial and Collaborative.

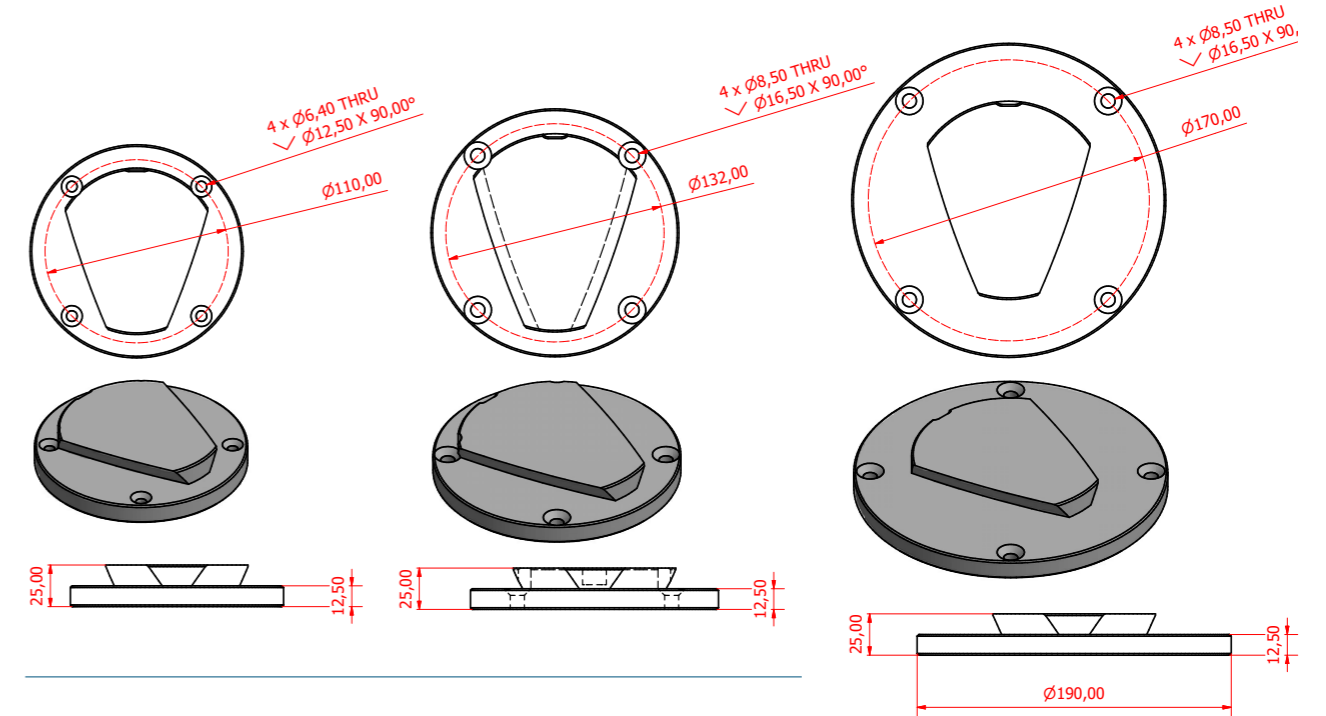

ITEM NO.
4500 / 4501 / 4502 / 4503 / 4504 / 4505 CUSTOM

MANUAL TOOL CHANGE LARGE INDUSTRIAL ROBOTS

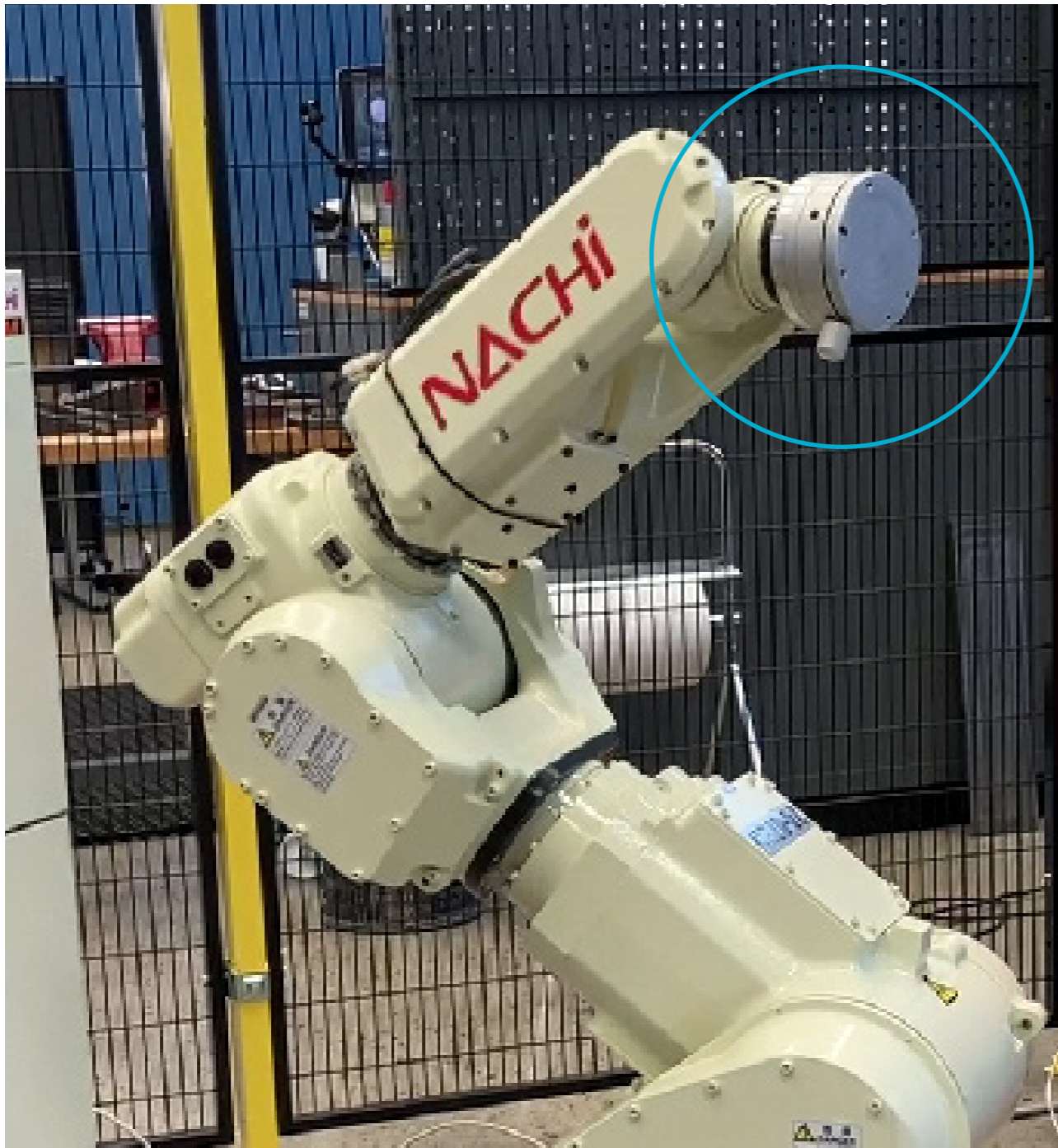

Manual Tool Change Large Industrial Robot

The Smartshift Robotics Manual Tool Change system for Large Industrial Robots efficiently supports the change in tool replacement when larger Robots are to change from one task to another, replace older tools or are in needs of EOAT Maintenance.

In stead of bolting and un bolting the EOAT, the Smartshift system acts as a safety also due to the swift and easy handling and maneuvering while releasing and attaching your needed robot equipment.

The same system is used as Base system for smaller robots and with its 3 different sizes as standard, but also the option to use adapters or have retro fitted bolt patterns, the Smartshift manual Tool Change systems is a preferred option for Robot cells in the higher payload range.



Manual Tool Change Large Industrial Robot Master

PRODUCT FEATURES AND SPECIFICATIONS

- **Fast and accurate movement**
Re-deploys in seconds
- **Accurate**
Re-positioning with the range of five hundredth of a millimeter.
- **Easy to use**
Quick release with accurate locking system.
- **Custom Base**
On request, Smartshift-robotics Custom manufacture bases to fit your Robot or Cobot type. Smartshift Base connects to all Robots, Industrial and Collaborative.
- **Handling payload** 500 kg
- **Weight:** Small: Medium: Large:

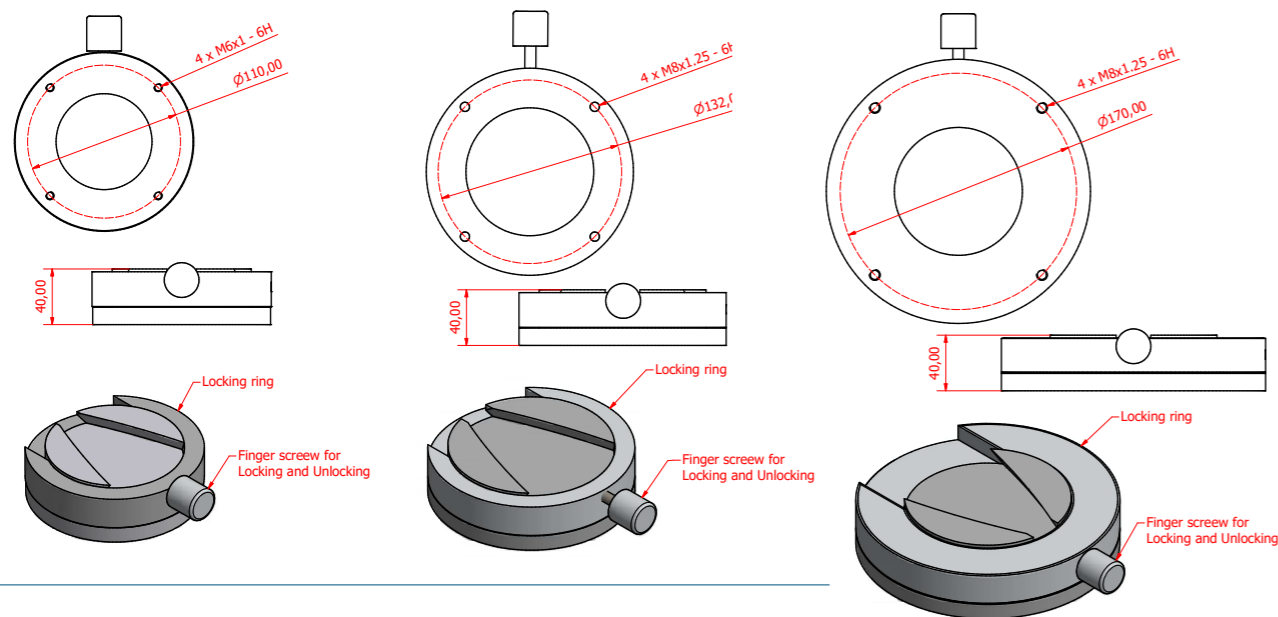

ITEM NO.

4000 / 4001 / 4002 / 4003 / 4004 / 4005 CUSTOM

Manual Tool Change Large Industrial Robot Base

PRODUCT FEATURES AND SPECIFICATIONS

- **Fast and accurate movement**
Re-deploys in seconds
- **Accurate**
Re-positioning with the range of five hundredth of a millimeter.
- **Easy to use**
Quick release with accurate locking system.
- **Custom Base**
On request, Smartshift-robotics Custom manufacture bases to fit your Robot or Cobot type. Smartshift Base connects to all Robots, Industrial and Collaborative.
- **Handling payload** 500 kg
- **Weight:** Small: Medium: Large:

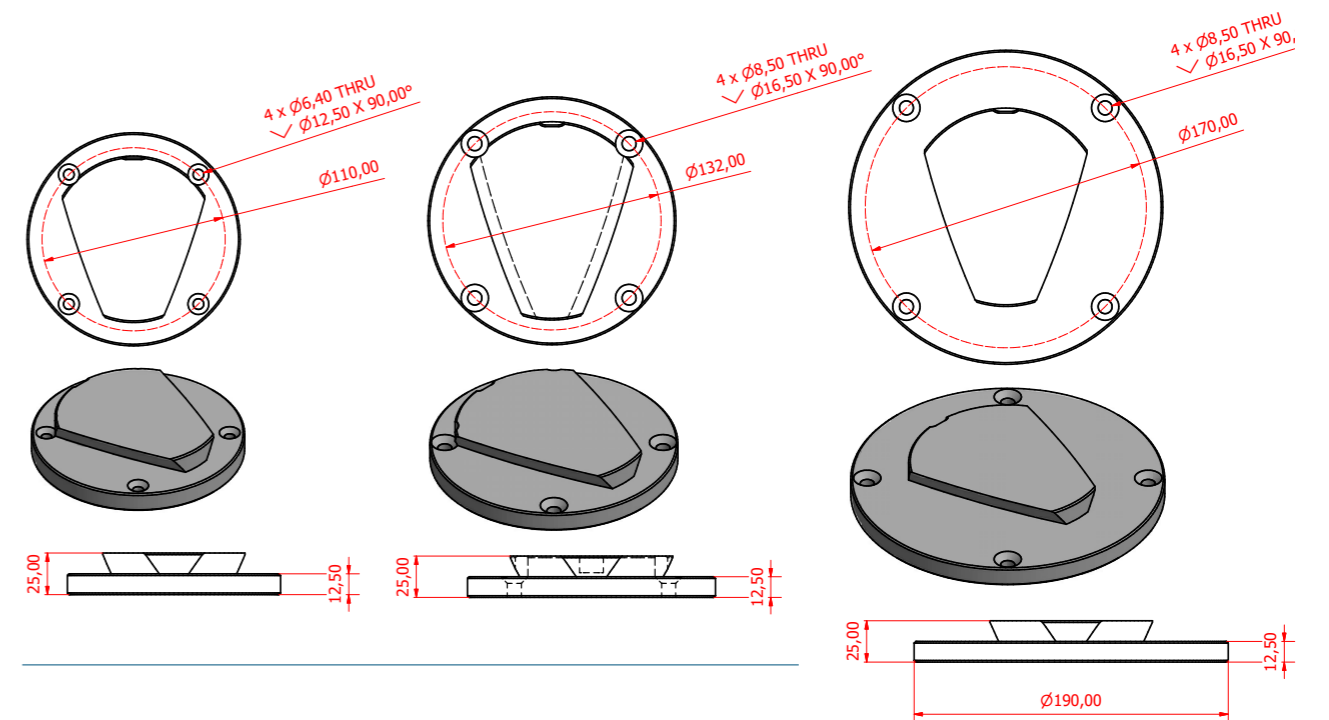

ITEM NO.

4500 / 4501 / 4502 / 4503 / 4504 / 4505 CUSTOM

Moving handle

PRODUCT FEATURES AND SPECIFICATIONS

- **Fast**
Helps re-deploy light weight cobots in seconds
- **Easy to use**
Gives stability when moving a Cobot from one location to another
- **Custom Handle**
On request, Smartshift-robotics Custom manufacture handles to fit your light weight Cobot type. Smartshift Base connects to all Robots, Industrial and Collaborative.



4910_MOVING HANDLE UR3

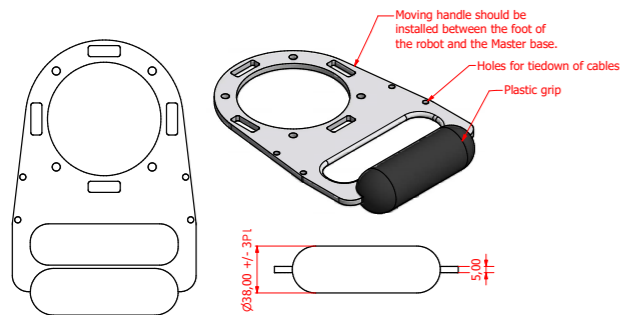

4911-MOVING HANDLE UR 5

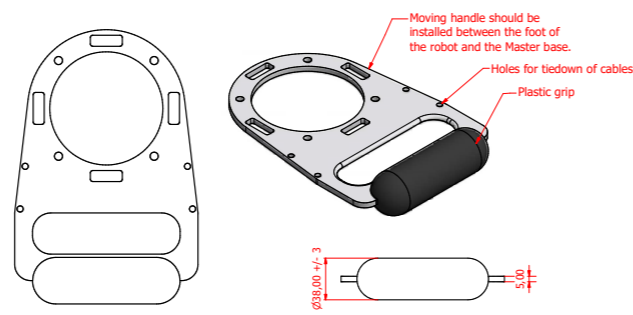

4912_MOVING HANDLE UR10_16

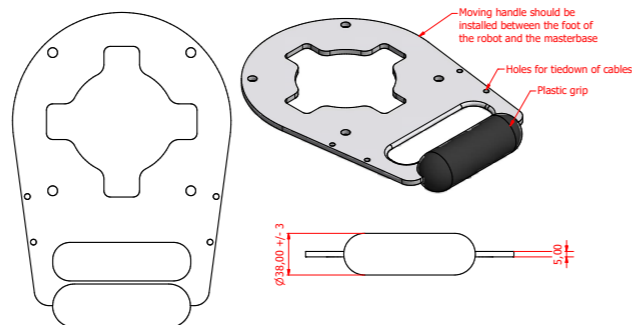

ITEM NO.
4910 / 4911 / 4912 / 4913

Manifold, pneumatic

PRODUCT FEATURES AND SPECIFICATIONS

- **Fast**
Works at high speed and precision.
- **Accurate**
With the range of five hundredth of a millimeter in all directions and angles.
- **Adapter**
Giving the spacing needed to securely run the automatic electrical tool changer, while using compressed air.
- **Installation**
Easy installation and hereby high security.
- **Handling payload**
50 kg
- **Connection**
Pneumatic 2xG 1/8"
- **Weight total**
110g



ITEM NO.
5000

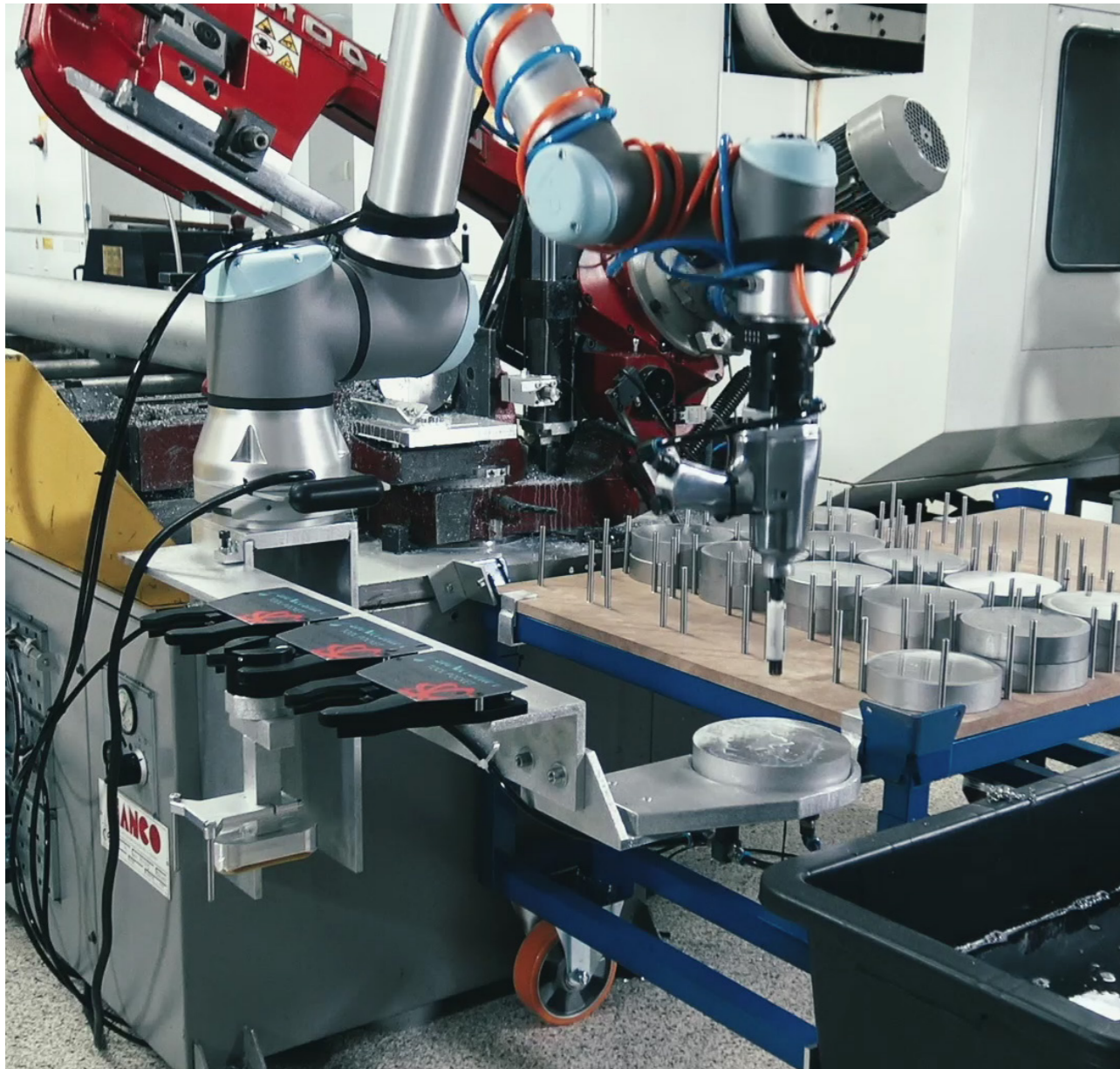

Adaptors and robot fittings

Available for Flange and Base

PRODUCT FEATURES AND SPECIFICATIONS

The compatibility of the universal Smartshift-robotics adaptor and fittings, system make this automatic tool change system compatible with most robot manufacturers on the market.

The product list of already standardized adaptors can be found on the web page or by contacting Smartshift-robotics directly.

All though just some model fittings are standardized, Smartshift-robotics will adjust, manufacture and work closely with you to secure a technically safe solution of highest standard that will make the Smartshift automatic tool change system to be mounted on to your preferred robot type and need.

Contact us for more details.

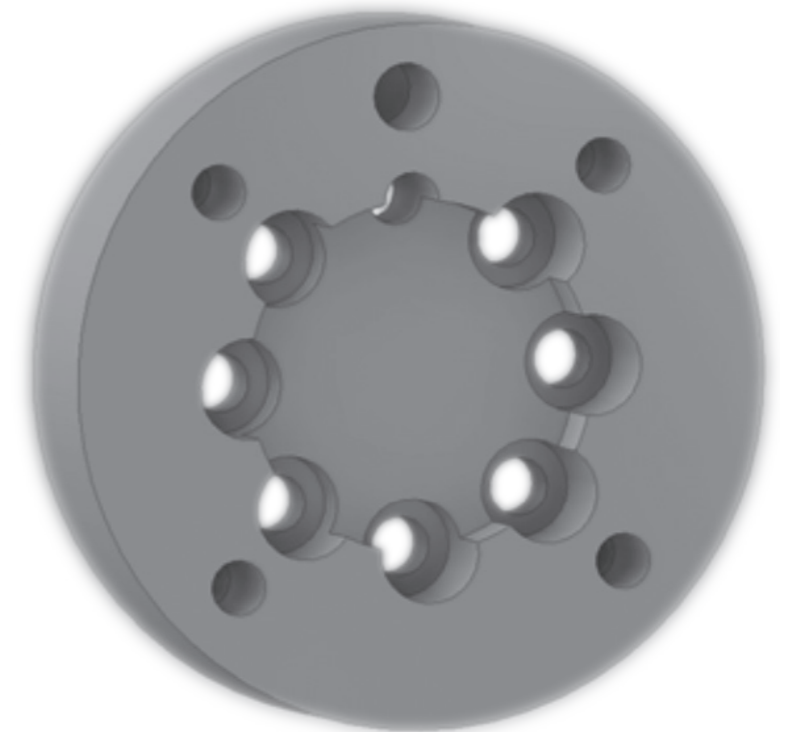

Flange Adapters

- Adapter BCD Ø31,5/20 M6x8
- Adapter BCD Ø40/31,5 M6
- Adapter BCD Ø50/31,5 M6x4
- Adapter BCD Ø64 14xM4
- Adapter BCD Ø64/31,5 M4x14
- Adapter BCD Ø50/21 M6x4
- Adapter BCD Ø50/20 M5x4
- Adapter BCD Ø31,5/20 M5x4
- Adapter BCD Ø40/25 M6x4
- Adapter BCD Ø96/30 M6x8
- Adapter BCD Ø50/14 M6x4
- Adapter BCD Ø60/23 M5x4
- Adapter BCD Ø53,5/21 M5x4
- Adapter BCD Ø60/31,5 M5x4
- Adapter BCD Ø63/40 M6x4
- Adapter BCD Ø80/50 M8x6
- Adapter BCD Ø50/31,5 M6x6
- Adapter BCD Ø64/57 M4x8
- Adapter BCD Ø64/57 M4x14
- Adapter BCD Ø40/25 M6x7
- Adapter BCD Ø56/50 M4x8
- Adapter BCD Ø40/20 M6x4
- Adapter BCD Ø25/10 M5x4
- Adapter BCD Ø31,5/12 M5x4
- Scara Adapter 16 mm
- Scara Adapter 20 mm
- Scara Adapter 22 mm
- Scara Adapter 25 mm
- Scara Adapter 30 mm
- Scara Adapter 35 mm

Adaptors and robot fittings

If your robot brand is not listed, please contact Smartshift Robotics.



WWW.ABB.COM/PRODUCTS/ROBOTICS



Any model within lift capacity of 0-50kg payload.

Standard Smartshift unit flange size:
Ø50mm, 4pcs M6. Center Ø31.5mm.

Model units/adapters in stock for:

Smartshift is compatible with all flange sizes and solutions from this manufacturer on demand. If the adapter/fitting is not listed, please contact Smartshift Robotics for an adjusted adapter/fitting for your preferred robot or cobot model.

IRB 1100, IRB 120, IRB 1200, IRB 1300, IRB 140, IRB 1410, IRB 1520ID, IRB 1600, IRB 1660ID, IRB 2400, IRB 2600, IRB 2600ID, GoFa, SWIFTI (CBR 1100)



WWW.AUBO-ROBOTICS.COM



Any model within lift capacity of 0-50kg payload.

Standard Smartshift unit flange size:
Ø50mm, 4pcs M6. Center Ø31.5mm.

Model units/adapters in stock for:
i3, i5, i10, i16, C3, C5, E3, E5, E10



WWW.DOBOT.CC



Any model within lift capacity of 0-50kg payload.

Standard Smartshift unit flange size:
Ø50mm, 4pcs M6. Center Ø31.5mm.

Model units/adapters in stock for:
Magician, CR3, CR5, CR5SS, CR10, CR16, MG400, MI SCARA

Adaptors and robot fittings

If your robot brand is not listed, please contact Smartshift Robotics.



WWW.DOOSANROBOTICS.COM



Any model within lift capacity of 0-50kg payload.

Standard Smartshift unit flange size:
Ø50mm, 4pcs M6. Center Ø31.5mm.

Model units/adapters in stock for:
M0609, M0617, M1013, M1509, A0509, A0509s, A0912, A0912s, H2017, H2515



WWW.FANUCAMERICA.COM



Any model within lift capacity of 0-50kg payload.

Standard Smartshift unit flange size:
Ø50mm, 4pcs M6. Center Ø31.5mm.

Model units/adapters in stock for:
LR Mate 200iD 4SH, LR Mate 200iD 4S, LR Mate 200iD 4SC, LR Mate 200iD 7H, LR Mate 200iD 7C, LR Mate 200iD 7WP, LR Mate 200iD, LR Mate 200iD 7L, LR Mate 200iD 7LC, LR Mate 200iD 14L, LR-10iA 10, M-10iD 8L, M-10iD 10L, M-10iD 12, M-10iD 16S, M-20iD 12L, M-20iB 25, M-20iD 25, M-20iB 25C, M-20iB 35S, M-20iD 35, M-710iC 12L, M-710iC 20L, M-710iC 20M, CR-35iA, CR-15iA, CR-14iA/L, CR-7iA, CR-7iA/L, CR-4iA, CRX-10iA, CRX-10iA/L, M-2iA/6H, M-2iA/6HL, M-3iA/6S, M-3iA/6A, M-3iA/12H, DR-3iB/8L, SR-6iA, SR-6iA/H, SR-12iA, SR-20iA, AM-120iD



WWW.HANWHA.COM



Any model within lift capacity of 0-50kg payload.

Standard Smartshift unit flange size:
Ø50mm, 4pcs M6. Center Ø31.5mm.

Model units/adapters in stock for:
HCR-3A, HCR-5A, HCR-12A

Adaptors and robot fittings

If your robot brand is not listed, please contact Smartshift Robotics.

WWW.HYUNDAI-ROBOTICS.COM



Any model within lift capacity of 0-50kg payload.

Standard Smartshift unit flange size:
Ø50mm, 4pcs M6. Center Ø31.5mm.

Model units/adapters in stock for:

Smartshift is compatible with all flange sizes and solutions from this manufacturer on demand. If the adapter/fitting is not listed, please contact Smartshift Robotics for an adjusted adapter/fitting for your preferred robot or cobot model.

HH4, YL005, YL012, YL015, HH4L, HH7, HH8, HA006L, HA006B, HH010L, HH012, HH020, HH020L, HH030L, YP015A-22, YP015A-28

WWW.JAKA.COM



Any model within lift capacity of 0-50kg payload.

Standard Smartshift unit flange size:
Ø50mm, 4pcs M6. Center Ø31.5mm.

Model units/adapters in stock for:

Zu 3, Zu 3s, Zu 5, Zu 5s, Zu 7, Zu 7s, Zu 12, Zu 12s, Zu 18, ZU 18s, Ai 3, Ai 5, Ai 7, Ai 12, Ai 18, MiniCobot

WWW.ROBOTICS.KAWASAKI.COM



Any model within lift capacity of 0-50kg payload.

Standard Smartshift unit flange size:
Ø50mm, 4pcs M6. Center Ø31.5mm.

Model units/adapters in stock for:

RS003N, RS005N, RS005L, RS006L, RS007N, RS007L, RS010N, RS010L, RS013N, RS015X, RS020N, RS030N

WWW.KUKA.COM



Any model within lift capacity of 0-50kg payload.

Standard Smartshift unit flange size:
Ø50mm, 4pcs M6. Center Ø31.5mm.

Model units/adapters in stock for:

Smartshift is compatible with all flange sizes and solutions from this manufacturer on demand. If the adapter/fitting is not listed, please contact Smartshift Robotics for an adjusted adapter/fitting for your preferred robot or cobot model.

KR 3 D1200 HM, KR 3 R540, KR 4 R600, KR 6 R700-2, KR 6 R900-2, KR 6 R700 CR, LBR iiwa 7 R800, LBR iiwa 7 R800 CR, LBR iiwa 14, R820, LBR iiwa 14 R820 CR, KR 6 R1840-2, KR 6 R1820, KR 6 R1820 HP, KR 8 R1640-2, KR 8 R1620, KR 8 R1620 HP, KR 8 R2010-2, KR 12 R1810-2, KR 16 R1610-2, KR 16 R2010-2, KR 20 R1810-2, KR 20 R1810 CR, KR 20 R3100, KR 30 R2100, KR 40 PA, KR 6 R500 Z200, KR 6 R700 Z200

WWW.KASSOWROBOTS.COM



Any model within lift capacity of 0-50kg payload.

Standard Smartshift unit flange size:
Ø50mm, 4pcs M6. Center Ø31.5mm.

Model units/adapters in stock for:

KR810, KR1018, KR1205, KR1410, KR1805

WWW.NACHIROBOTICS.COM



Any model within lift capacity of 0-50kg payload.

Standard Smartshift unit flange size:
Ø50mm, 4pcs M6. Center Ø31.5mm.

Model units/adapters in stock for:

Smartshift is compatible with all flange sizes and solutions from this manufacturer on demand. If the adapter/fitting is not listed, please contact Smartshift Robotics for an adjusted adapter/fitting for your preferred robot or cobot model.

MZ03EL, MZ04, MZ07, MZ07L, MZ01, MC10L, MZ12, MC12S, , MC20 MR20, ML20, MZ25, MC35, MR35

Adaptors and robot fittings

Adaptors and robot fittings

If your robot brand is not listed, please contact Smartshift Robotics.

OMRON

WWW.TM-ROBOT.COM



Any model within lift capacity of 0-50kg payload.

Standard Smartshift unit flange size:
Ø50mm, 4pcs M6. Center Ø31.5mm.

Model units/adapters in stock for:
TM5-700, TM5-900, TM12, TM14, Quattro 650H/HS,
Quattro 800H/HS, Hornet 565, Viper 650

HAN'S ROBOT
大族机器人

WWW.HANSROBOT.COM



Any model within lift capacity of 0-50kg payload.

Standard Smartshift unit flange size:
Ø50mm, 4pcs M6. Center Ø31.5mm.

Model units/adapters in stock for:
E3, E5, E5-L, E10, E15,

Adaptors and robot fittings

If your robot brand is not listed, please contact Smartshift Robotics.

DENSO
robotics

WWW.DENSOROBOTICS.COM



Any model within lift capacity of 0-50kg payload.

Standard Smartshift unit flange size:
Ø50mm, 4pcs M6. Center Ø31.5mm.

Model units/adapters in stock for:
LPH, MH, HS-A1, HSR, VL series, VM series, VMB series,
VP series, VSA series, VSG series

COMAU

WWW.COMAU.COM



Any model within lift capacity of 0-50kg payload.

Standard Smartshift unit flange size:
Ø50mm, 4pcs M6. Center Ø31.5mm.

Model units/adapters in stock for:
Rebel-S6-0.45, Rebel-S6-0.60, Rebel-S6-0.75, Racer-5-0.63,
Racer-5-0.80, Racer-3-0.63, Racer-7-1.0, Racer-7-1.4, NS-12-1.85,
NS-16-1.65, NJ-16-3.1, NJ-40-2.5

UNIVERSAL ROBOTS

WWW.UNIVERSAL-ROBOTS.COM



Any model within lift capacity of 0-50kg payload.

Standard Smartshift unit flange size:
Ø50mm, 4pcs M6. Center Ø31.5mm.

Model units/adapters in stock for:
UR3e, UR5e, UR10e, UR16e, UR CB3 10

YASKAWA

WWW.YASKAWA.EU.COM



Any model within lift capacity of 0-50kg payload.

Standard Smartshift unit flange size:
Ø50mm, 4pcs M6. Center Ø31.5mm.

Model units/adapters in stock for:
GP7, GP8, GP12, GP25, SG400, SG650, MPP3S, MPP3H, Motomini

MITSUBISHI
ELECTRIC

WWW.MITSUBISHIELECTRIC.COM



Any model within lift capacity of 0-50kg payload.

Standard Smartshift unit flange size:
Ø50mm, 4pcs M6. Center Ø31.5mm.

Model units/adapters in stock for:
RV-2FR, RV-2FRL, RV-4FR, RV-4FRL, RV-7FR, RV-7FRL,
RV-7FRL, RV-13FR, RV-13FRL, RV-20FR, RH-3FRH35,
RH-3FRH45, RH-3FRH55, RH-6FRH35, RH-6FRH45,
RH-6FRH55, RH-12FRH55, RH-12FRH70, RH-12FRH85,
RH-20FRH85, RH-20FRH100, RV-8CRL, RV-4F, RV-4FL,
RV-7F, RV-7FL, RV-7FLL, RV-13F, RV-13FL, RV-20FR,
RV-35F, RH-3FH35, RH-3FH45, RH-3FH55, RH-6FH35,
RH-6FH45, RH-6FH55, RH-12FH55, RH-12FH70,
RH-12FH85, RH-20FH85, RH-20FH100, MELFA ASSISTA

Adaptors and robot fittings

If your robot brand is not listed, please contact Smartshift Robotics.

 ELITE ROBOT

WWW.ELIBOT.CN



Any model within lift capacity of 0-50kg payload.

Standard Smartshift unit flange size:
Ø50mm, 4pcs M6. Center Ø31.5mm.

Model units/adapters in stock for:
EC63, EC66, EC612, CS63, CS66, CS612

 YAMAHA

WWW.YAMAHA-ROBOTICS.COM/



Any model within lift capacity of 0-50kg payload.

Standard Smartshift unit flange size:
Ø50mm, 4pcs M6. Center Ø31.5mm.

Model units/adapters in stock for:
YA-RJ, YA-R3F, YA-R5F, YA-R5LF, YA-R6F,
YA-U5F, Ya-U10F, Ya-U20F, Scara

SMARTSHIFT PRODUCT LIST

ITEM NO.	PRODUCT NAME	NOK	EURO	DOLLAR
----------	--------------	-----	------	--------

SMARTSHIFT TOOLS

MASTER

1000	Robot master
1100	Robot master electric female
1101	Robot master electric male
1103	Robot master Gen III electric connector Industrial
1123	Robot master Gen III el. Straight connector male
1113	Robot electric connector Industrial
1120	Robot Master Gen III
1121	Robot Master Gen III electric female
1122	Robot Master Gen III electric male
1110	Robot Electric M8 connector female
1111	Robot Electric M8 connector male
1114	Robot Electric M8 straight connector male
1115	Robot Electric M8 straight connector female
1500	Robot master light

TOOL HOLDER

2000	Tool holder
2010	Tool holder with pneumatic manifold
2100	Tool holder electric male
2101	Tool holder electric female
2120	Tool holder Gen III
2121	Tool holder Gen III electric male
2122	Tool holder Gen III electric female
2102	Tool holder electric male with pneumatic manifold
2103	Tool holder electric female with pneumatic manifold
2104	Tool holder Gen III electric connector
2110	Tool Electric M8 connector male
2111	Tool Electric M8 connector female
2500	Tool holder light

TOOL POCKET

3000	Tool pocket
------	-------------

MANIFOLD

5000	Manifold, pneumatic
------	---------------------

For a price quote, contact your local reseller of Smartshift tools, please see our resellers list. If there is no local reseller in your region, please contact Smartshift Robotics directly, and we will support you for your application need: sales@smartshift-robotics.com

SMARTSHIFT PRODUCT LIST

ITEM NO.	PRODUCT NAME	NOK	EURO	DOLLAR
----------	--------------	-----	------	--------

SMARTSHIFT ACCESORIES

SMARTSHIFT ACCESORIES

4900	Base bracket UR			
4901	Base Bracket Doosan			
4902	Base bracket – Custom made			
5201	Smartshift safety sensor			
8000	Weld torch holder			

SMARTSHIFT BASESHIFT

MASTER BASE

4000	Master base	UR 3		
4001	Master base	UR 5		
4002	Master base	UR 10/16		
4003	Master Base	UR 10 CB3		
4004	Master Base	Doosan		
4005	Master Base –	Custom made		
4006	Master base	Kassow KR810-KR1205		
4007	Master base	Kassow KR1018-KR1410-KR1805		
4008	Master base	Hanwha HCR12		
4009	Master base	Hanwha HCR3		
4010	Master base	Hanwha HCR5		
4011	Master base	Fanuc LR Mate 200iD		

BASE PLATE

4500	Baseplate	UR3		
4501	Baseplate	UR5		
4502	Baseplate	UR10/16		
4503	Baseplate	UR10 CB3		
4504	Baseplate	Doosan		
4505	Baseplate –	Custom made		
4506	Baseplate	Kassow KR810 – KR1205		
4507	Baseplate	Kassow KR1410, KR1805, KR1018		
4508	Baseplate	Hanwha HCR12		
4509	Baseplate	Hanwha HCR3		
4510	Baseplate	Hanwha HCR5		
4511	Baseplate	Fanuc LR Mate 200iD		

For a price quote, contact your local reseller of Smartshift tools, please see our resellers list. If there is no local reseller in your region, please contact Smartshift Robotics directly, and we will support you for your application need: sales@smartshift-robotics.com

SMARTSHIFT PRODUCT LIST

ITEM NO.	PRODUCT NAME	NOK	EURO	DOLLAR
----------	--------------	-----	------	--------

MOVING HANDLE

4910	Moving handle	UR3		
4911	Moving handle	UR5		
4912	Moving handle	UR10\16		
4913	Moving handle	Doosan		
4914	Moving handle	Hanwha HCR12		

FLANGE ADAPTER

FLANGE ADAPTER INDUSTRIAL ROBOT

5101	Adapter BCD	Ø31,5/20 M6x8		
5102	Adapter BCD	Ø40/31,5 M6		
5103	Adapter BCD	Ø63/31,5 4xM6		
5107	Adapter	Yaskawa HC10		
5108	Adapter	Scara Ø16 Shaft		
5109	Adapter BCD	Ø64 14xM4		
5110	Adapter BCD	Ø64/31,5 M4x14		
5111	Adapter BCD	Ø50/21 M6x4		
5112	Adapter BCD	Ø50/20 M5x4		
5113	Adapter BCD	Ø31,5/20 M5x4		
5114	Adapter BCD	Ø40/25 M6x4		
5115	Adapter BCD	Ø96/30 M6x8		
5116	Adapter BCD	Ø50/14 M6x4		
5117	Adapter BCD	Ø60/23 M5x4		
5118	Adapter BCD	Ø53,5/21 M5x4		
5119	Adapter BCD	Ø60/31,5 M5x4		
5120	Adapter BCD	Ø63/40 M6x4		
5121	Adapter BCD	Ø80/50 M8x6		
5122	Adapter BCD	Ø50/31,5 M6x6		
5123	Adapter BCD	Ø64/57 M4x8		
5124	Adapter BCD	Ø64/57 M4x14		
5125	Adapter BCD	Ø40/25 M6x7		
5126	Adapter BCD	Ø56/50 M4x8		
5127	Adapter BCD	Ø40/20 M6x4		
5128	Adapter BCD	Ø25/10 M5x4		
5129	Adapter BCD	Ø31,5/12 M5x4		

For a price quote, contact your local reseller of Smartshift tools, please see our resellers list. If there is no local reseller in your region, please contact Smartshift Robotics directly, and we will support you for your application need: sales@smartshift-robotics.com

SMARTSHIFT PRODUCT LIST

ITEM NO.	PRODUCT NAME	NOK	EURO	DOLLAR
----------	--------------	-----	------	--------

FLANGE ADAPTER SCARA ROBOT

5150	Scara Adapter 16 mm			
5151	Scara Adapter 20 mm			
5152	Scara Adapter 22 mm			
5153	Scara Adapter 25 mm			
5154	Scara Adapter 30 mm			
5155	Scara Adapter 35 mm			

For a price quote, contact your local reseller of Smartshift tools, please see our resellers list. If there is no local reseller in your region, please contact Smartshift Robotics directly, and we will support you for your application need: sales@smartshift-robotics.com



THE SMARTSHIFT ROBOTICS FACTORY IN HØNEFOSS, NORWAY.



World wide ROBOTIC APPLICATION Solutions

 Smartshift-robotics tools are supplied to manufacturing Companies across the globe within all Industries where an Automatic tool changing system is relevant to secure efficient, precise and profitable benefits for the manufacturers end-results.

With local partners established in key destinations across the globe, spanning within the range of the many robot brands and sizes, Smartshift-robotics will continue to secure easy and safe deliveries of the Smartshift-robotics tools to Your designated location.

We will continue expanding our network - come join the Smartshift family!



Technical Instructions

User Manual



Original instructions
User manual

Manufacturer: Smartshift Robotics AS
Machine type: SmartShift
Designation: Tool Change system
Manufacturing year: 2019

Company

Smartshift Robotics AS
Hensmoveien 17
NO-3516 Hønefoss
Phone: +47 92 17 07 80
E-mail: sales@smartshift-robotics.com



Machine name: SMARTSHIFT Clutch
Revision: 06
Revisions date: 2019.10.15
Made in Norway - Original instructions - User manual

Original instructions – User manual

1 Introduction

The SMARTSHIFT clutch/Tool Change system is designed for manual or automatic robotic tool shifting.

The Smartshift Tool Change system is one of, if not the fastest Robot Tool Change system Globally today. We can offer our Tool Change system to Small robots, Collaborative Robots, SCARA Robots, Delta Robots, Small and Large Industrial Robots. SMARTSHIFT basic clutch set consists of three units: A Tool Pocket (TP), a Robot Master (RM), and Tool Holders (TH) with pneumatically connection and optional Electrical (E) connections. Several tool change set variations and application tool selections are therefore possible.

With a fast cycle time Change, Smartshift is giving Robot installation flexibility and increasing the usage of Robots in general. With the "tool belt" equipment of Smartshift, you are ready to automate more tasks, in shorter time, not being bound by Robot choice. Smartshift operates as a Mechanical shifter, and does not interfere with software communication. This way Smartshift supports all manufacturers of Robots and machines that need parallel or multiple tasking operations during an operation.

Variety examples:



Machine name: SMARTSHIFT Clutch
Revision: 06
Revisions date: 2019.10.15
Made in Norway - Original instructions - User manual

Product information:

Machin type: SMARTSHIFT Clutch

Drawing number: X

Type designation: xxxxxxxx

Manufacturing year: 2019

Manufacturer:

Name: Smartshift Robotics AS

Reference: Kjell Buind

Address: Hensmoveien 17,

3516 Hønefoss

Norway

2 Table of Contents

1	INTRODUCTION	2
2	TABLE OF CONTENTS	4
3	GENERAL DESCRIPTION	5
3.1	THE SMARTSHIFT AUTOMATIC AND MANUAL CLUTCH	5
3.2	ROBOT MASTER SPECIFICATIONS	6
3.3	TOOL HOLDER SPECIFICATIONS	6
3.4	TOOL POCKET SPECIFICATIONS	7
3.5	ROBOT MASTER ELECTRICAL SPESIFICATIONS	7
3.6	TOOL HOLDER ELECTRICAL SPESIFICATIONS	8
3.7	SMARTSHIFT SENSOR (Optional Ad on)	9
4	SAFETY INSTRUCTIONS	9
4.1	GENERAL SAFETY	9
5	MOUNTING	10
5.1	SETUP GUIDE TOOL POCKET	10
5.2	SETUP GUIDE ROBOT MASTER	11
5.3	SETUP GUIDE MANIFOLD	12
5.4	PNEUMATIC "Ad on" extended multifunction	13
6	ELECTRIC TOOL CHANGE	15
7	WORK SPACE	16
8	ELECTRIC CABLE CONNECTION	17
9	MAINTENANCE	18
9.1	GENERAL	18
9.2	LUBRICATION	18
10	MOUNTING OF "AD ON" ELECTRIC M8 8 PIN CONNECTOR	19
11	ALIGNED INSTALLING "AD ON"	21
12	GENERAL USAGE	23
13	TCP SETUP	24
14	RUNNING TOOL CHANGE – PICK UP SETUP	25

3 General description

3.1 The SMARTSHIFT Clutch

The automatic and manual SMARTSHIFT clutch is capable of connecting mechanical, pneumatically and electrical tools for robots and consists of following three main units: A Robot Master (RM), mounted on the robot such as the Universal Robots or similar equipment. Tool Pocket (TP) and Tool Holders (TH) applies in a number and variations depending on demands for tool applications at the robot. In automatic mode, the robot exchange tools in a simple process sequence by placing a Tool Holder (TH) in an empty Tool Pocket (TP) and select another Tool Holder (TH) from another Tool Pocket (TP). Tools also exchanges manually if desired.

Detail Overview

- A) Robot Master (RM)
- B) Tool Holder (TH)
- C) Tool Pocket (TP)
- D) Robot Master with electrical connectors (RME)
- E) Tool Holder with electrical connectors (THE)

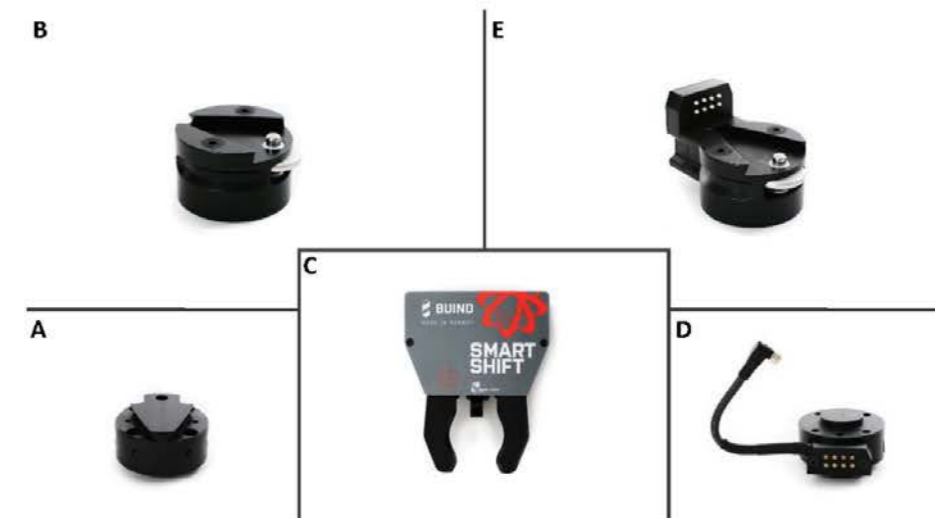

3.2 Robot Master (RM) specification

Recommended for robots handling payload up to: 50 kg
Pneumatic/Vacuum connection: Double connection with two G1/8"
Electrical connection: Up to eight pins
Outer diameter: 63 mm
Flange diameter 31.5 mm h7
Reference diameter: \varnothing 50 mm
Total Weight: 150 g
Material: POM-C (The entire part is POM-C)

Adapter for other Robot flange fit, on demand/on stock.

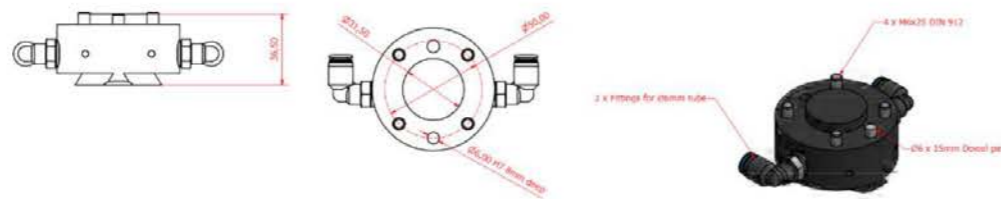

3.3 Tool Holder (TH) specification

Recommended for robots handling payload up to: 50 kg
Pneumatic/Vacuum connection: Double connection with two G1/8"
Electrical connectors: Up to 8 pins
Outer diameter: 63 mm
Flange diameter 31.5 mm h7
Reference diameter: \varnothing 50 mm
Total Weight: 255 g
Material: Aluminium 6082-T6 Anodized (Tool holder and Disc) stainless steel (Locking pin), Rubber (Air pass through sealants)

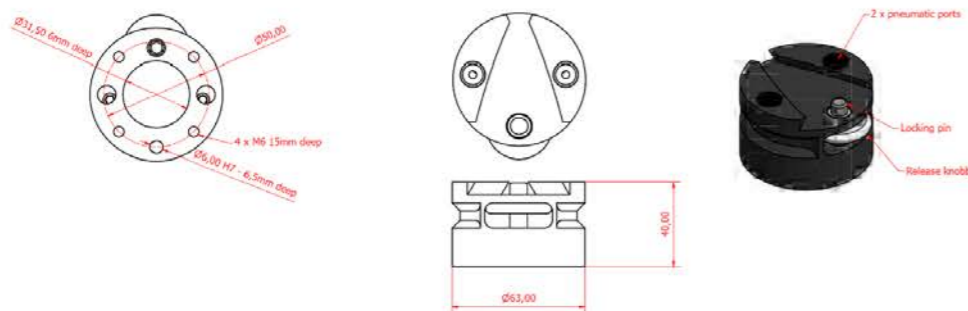

3.4 Tool Pocket (TP) specification

Recommended handling weight: Up to 5 kg
Total weight: 710 g
Materials: Aluminium 6082-T6 Anodized (Bottom plate, top plate), POM-C (Gripper holder arms), stainless steel EN10278 (Spacers) PVC (Sticker)

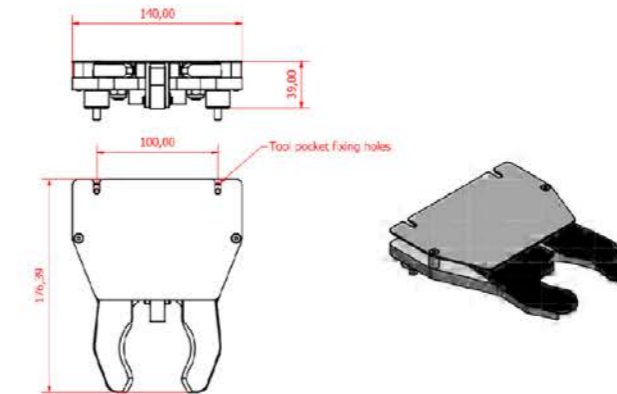

3.5 Robot Master Electrical (RME) specification

Recommended for robots handling payload up to: 50 kg
Pneumatic/Vacuum connection: Double connection with two G1/8"
Electrical connection: Up to eight pins
Outer diameter: 63 mm
Flange diameter 31.5 mm h7
Reference diameter: \varnothing 50 mm
Total Weight: 180 g
Material: POM-C (The entire part is POM-C)

Eight pins electrical pass-through rated for 1.0 AMP per 8 pin
Materials: Brass, Silver coated, copper cable, ABS plastic
IMPORTANT: Power connection must be OFF during clutching in and out. A charged pin will create a spark that will destroy the connector pins by welding/burns.

Adapter for other Robot flange fit, on demand/on stock.

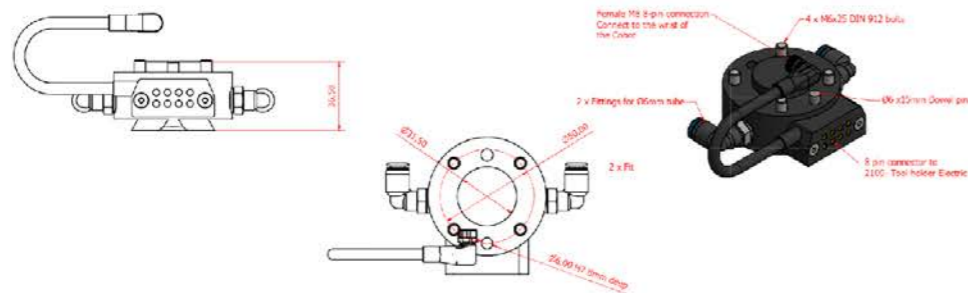

3.6 Tool Holder Electrical (THE) specification

Recommended for robots handling payload up to: 50 kg
Pneumatic/Vacuum connection: Double connection with two G1/8"
Electrical connectors: Up to 8 pins
Outer diameter: 63 mm
Flange diameter 31.5 mm h7
Reference diameter: Ø 50 mm
Total Weight: 310 g
Material: Aluminium 6082-T6 Anodized (Tool holder and Disc) stainless steel (Locking pin), Rubber (Air pass through sealants)

Eight pins electrical pass-through rated for 1.0 AMP per 8 pin
Materials: Brass, Soldering tin, copper cable, ABS plastic
IMPORTANT: Power connection must be OFF during clutching in and out. A charged pin will create a spark that will destroy the connector pins by welding/burns.



3.7 Smartshift sensor (Optional Ad on)

Using Inductive sensor, Smartshift provides, on demand, a safety function to its clutch system. The sensor is mounted in the Robot Master (RM) on delivery (on demand add on) or can be delivered on the side for installation by the end user. The sensor works as a safety and stop function, using the Inductive sensor to communicate with the Robot. The sensor function is to prevent pore connection on pick up (ex. Dusty environment) or missed pick up in general. The sensor detects Inductive if the lock pin on the Tool Holder (TH) is in correct lock position inside the Robot Master (RM).

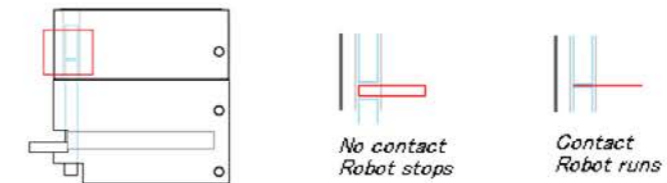

4 Safety instructions

4.1 General safety

Keep hands and tools away from all SMARTSHIFT components when the program is running. Follow this manual carefully also regarding maintenance and recommended weight. Always have security data sheet for recommended lubrication available. If the SMARTSHIFT clutch is damaged, then stop using immediately and contact Smartshift Robotics AS for replacement parts. Notice that the Tool Pocket and Tool Holder is spring loaded and the electrical units carries current. Smartshift is not responsible for damage to people and property caused by using damaged components.

5 Mounting

Mount Robot Master (RM) directly onto the Robot flange or on similar equipment using the provided flange mounting screws. If flange fit is other than standard Smartshift unit, use provided adapter. If no adaptor is supplied, contact Smartshift Robotics AS.

Mount the Tool Pocket (TP) horizontally and place it so that the robot easily can pick and place Tool Holders (TH) from Tool Pocket (TP). Mount the tool for your application on the Tool Holder (TH), recommended handling weight is 5.0 kg. The owner is fully responsible for mounting the SMARTSHIFT clutch securely.

5.1 Setup guide Tool Pocket

Unscrew the top plate by loosening the two M4 screws.



Remove the top-plate and the two cylindrical spacers under the top-plate.



Put two M6 screws through the two mounting holes on top of the gripper plate and through the two larger cylindrical spacers provided (see mount units bag attached on delivery).

Put the gripper on top of a flat and stable surface with threaded holes and tighten down the two M6 screws.

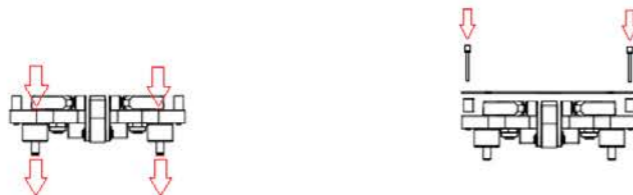

Put the top-plate back on the gripper with the spacer cylinders and tighten down the two M4 screws just enough to keep the top plate from moving

5.2 Setup guide Robot Master

Smartshift mounting of Robot Master is intended directly on to the Robot (of choice) flange connection. Smartshift delivers a standard size:

Outer diameter: 63 mm
Flange diameter 31.5 mm h7
Reference diameter: \varnothing 50 mm

The 4 screw connection (included on delivery) is to be mounted directly on to the Robot flange with a force of no more than recommended 3 Newton (N) / 26,552 in.lbf to ensure the Smartshift unit is accurately mounted. More pressure than the recommended force could result in damage or uneven surface that can inflict on the accuracy pick up of the Robot Master (RM) and Tool Holder (TH). If damaged, tightened to hard and an even pick up is registered, Smartshift suggests loosening the pressure back to recommended tightening strength or contact Smartshift Robotics AS for service, repair or replacement of part. If no Torque tool, we recommend using the Umbraco as shown.

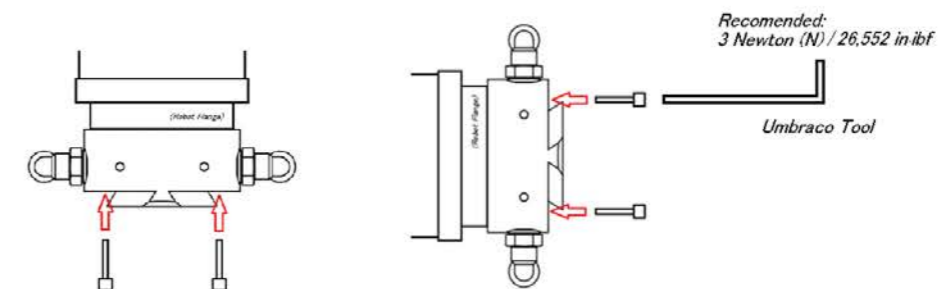

If there is no accurate fit to the Robot flange, contact Smartshift Robotics AS for a daptor to fit the connection.

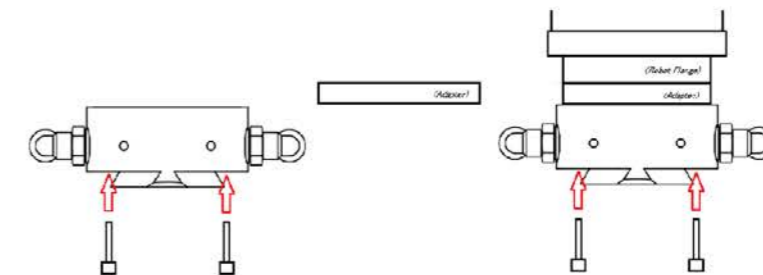

5.3 Setup guide Manifold (pneumatic)

Smartshift delivers every item with Pneumatic functionality. By using Pneumatic/Vacuum connection: Double connection with two G1/8", use of compressed air is installed on all units on delivery.

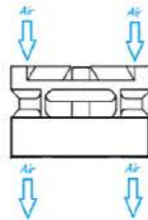

Smartshifts unique solution to the use of Pneumatics is based on the Tool side of the functionality. The Manifold is the component that directs the air out from the sides, under the Tool Holder (TH). With two G1/8", Smartshift's solution to handling complex and multi functional vacuum applications is either using:



two air ports for vacuum

two ports for compressed air

one port for vacuum and one for compressed air

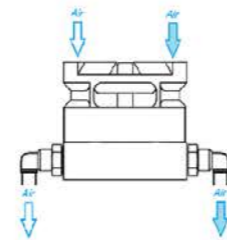
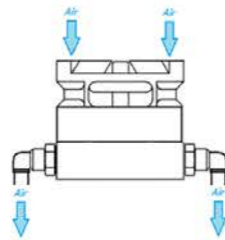
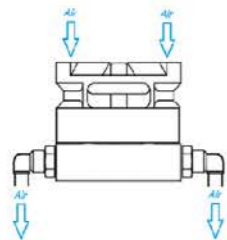

Smartshift Manifold is to be used if the air is to be directed out on the sides and not directly in to the tool, mounted on the Tool Holder (TH).

In many cases there is NO NEED for the Smartshift Manifold, since the air is to be connected directly into the tool, from under the Tool Holder (TH).



5.4 Pneumatic "Ad on" extended multifunction

Smartshift Collaborative and small Industrial Robot Tool Change system is delivered with Double connection with two G1/8". When, or, if in need of more or several pneumatic ports, the Smartshift pneumatic solution is built with the intention and purpose to remove all unnecessary cabling and tubing's along the Robots flange area. This way Smartshift provides safety in terms of potential damage when using a Robot in a multitask and high tech solution environment.

With the two pneumatic ports, Smartshift can lift the payload equal to the payload max weight of the Tool Change system. Max lift capacity set at 50 Kg payload. This depending on correct use of vacuum cups in size, surface arranged equipment and quantity needed.

The Smartshift pneumatic "Ad On" multifunction recommend the use of a pneumatic steering block included "BUS" connection for signal transfer and technical use. By using the M8 8 pin connecting cables (suggested is the Industrial version, or, cutting of the M8 connector) wiring is needed to attached the pneumatic steering block. Be sure to use professional assistance(Smartshift is not eligible for any damage done by non-certified personnel) when wiring.

When using a pneumatic steering block, you can increase numbers of airports from 2 pneumatic ports using multi use tooling and also if need upgrade to Bus for signal transfer.

(Picture example: Pneumatic steering Block FESTO VTUG-10-MSDR-B1TZ-25V20-Q10L-UL-Q6S-6P, giving 7 airports and option for Bus communication)

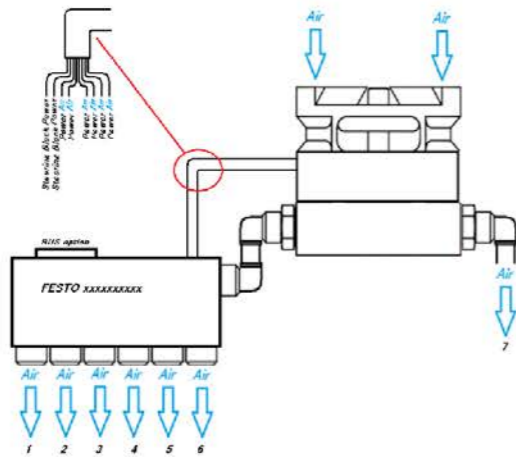

If in need of extra supply of air pressure, the second air port on the Tool Holder (TH) can be added on to the steering Block. (Picture example: Pneumatic steering Block FESTO VTUG-10-MSDR-B1TZ-25V20-Q10L-UL-Q6S-6P)

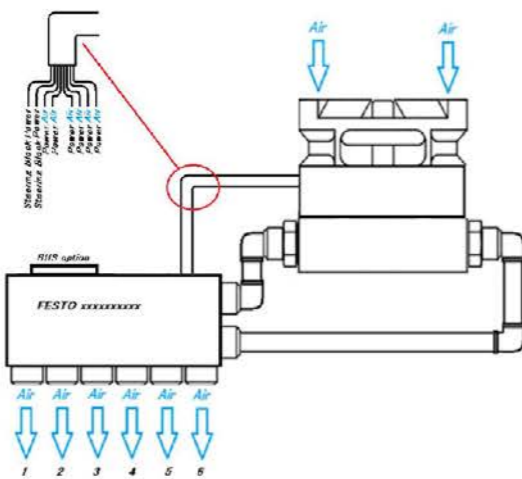

6 Electric Tool Change

When running an electric tool change sequence, it is important to remember switching on and off the electric flow.

Example: Robot + Smartshift Tool Change + electric tool.

When running this operation there will be a constant power flow from the robot to the electric tool. Smartshift electric tools are a pure pass-through unit and does not regulate the power flow when using the Tool Change system. This way you need to create an On/Off move when picking up or delivering the electric tool in the Tool Pocket (TP). Not creating this command on the robot may damage the Robot or electric tool due to short-circuit damage. Being a mechanical system with only pure pass-through function, Smartshift is not eligible for any damage to the use of external units.

When pick up of tool, turn off power supply to tool. Once tool is picked up, turn power supply on again. The same is done on delivery in the opposite direction.

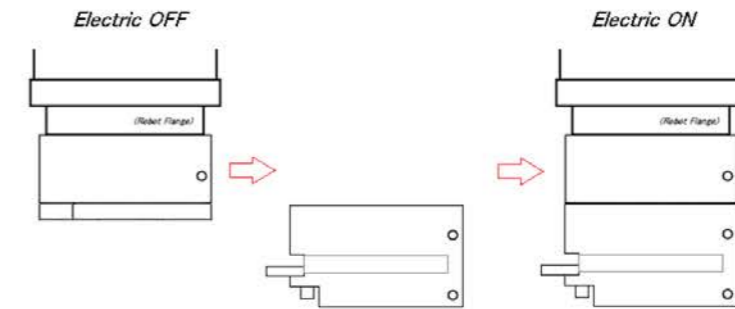

7 Work space

Smartshift Tool Change system has a 50 Kg Payload max work force (the Tool Change units used + weight on what the Robot will be lifting). The Tool Change system has a repeatability of 0.05mm measured within the "Green zone" of the Tool Change measurement system. Working outside of this area the repeatability may exceed the 0.05mm accuracy from TCP (Tool centre point).

Smartshift accuracy is measured at:

Horizontal distance from scenter TCP 0 cm to 7,5 cm.

Vertical distance from scenter TCP 0 cm to 30 cm.

Degrees (hot/cold) work environment set at +5 / +40 C. (At low temperature below 0 C and above +40 C the Smartshift tool can still be run, but increased friction outside the 0.05 mm repeated accuracy between Master (RM) and Tool Holder (TH) may be exceeded.)

At low weight, repeatability may though be accurate even with extended tool ad-on. If deviation accrues Smartshift suggest centring the on mounted tooling for more accurate repeatability, or use off loader support systems.

General explanation; closer to TCP – higher payload.

Examples: Heavy weld Torch, uneven rods and poles, uneven balanced tools.

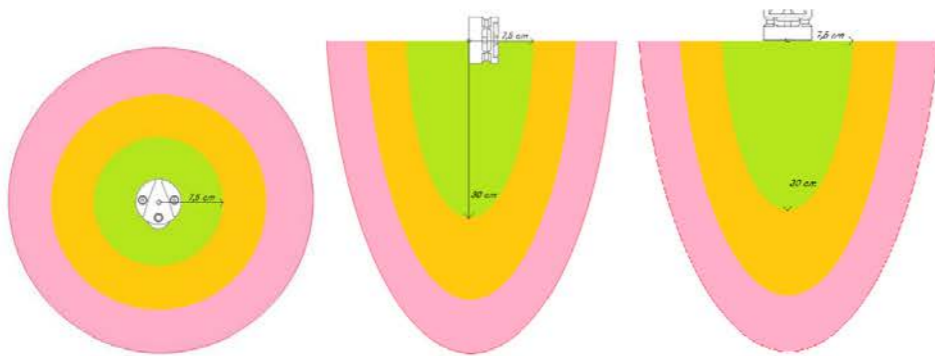

8 Electric Cable connection

Collaborative Robots

Smartshift uses as standard M8 8 pin 24 V AMP, Female and Male connector.

The connectors are generally used as standard connectors on the Collaborative robots. Female, Male, or both Female and Male connectors vary from manufacturer to manufacturer. When installing a Smartshift Robot Master on to the flange connection on a Collaborative robot with the M8 8 pin connector, Smartshift Robot Master installs as a plug-n-play function. **IMPORTANT!** Be sure to have the correct connector match. (Example; Male connector on flange of robot – Female connector on Smartshift Robot Master – Then Male connector on Smartshift Tool Holder.)

Smartshift also offers the standard M8 8 pin connectors as ad-on. (See catalogue) The M8 8 pin connector ad on units makes Smartshift unique, functioning as a "lego" system where you can upgrade existing units without electric connection, or unmount the electrical connection ad on if no need for electrical use.



Industrial Robots

Smartshift uses as standard M8 8 pin 24 V AMP, Female and Male connector. When installing the Smartshift Robot Master on Industrial robots you need the Industrial version of the M8 8 pin connector. This connector is delivered without the M8 8 pin flange connector. Installation is done directly on to the electrical system on the Industrial Robot wiring or electric junction box. Standard length of cable set at approx. 1 meter. Can be ordered at other length on demand.



9 Maintenance

9.1 General

Make sure to keep SMARTSHIFT in a clean environment. If chips or other big particles comes between the Robot Master (RM) and the Tool Holder (TH) the lifetime of the SMARTSHIFT system can be shortened. Smartshift also recommends air blow cleaning.

9.2 Lubrication

Once every second week, put a few drops of silicon-based lubricant (silicone spray) on each rubber seal, a few drops on each surface to keep the components sliding easily against each other, and a few drops on the locking pin to, keep the pin sliding easily. Recommended silicone spray is WD-40 300014 silicone oil, or equivalent silicone-based lubricant.

Silicon Lubricant to be used on: V-shaped connection area, lock pin, lock wheel and (important) sealing of pneumatic connections.



10 Mounting of Ad on Electric M8 8 pin connector to Master and Tool Holder unit

Smartshift Tool Change system is an ad on system that allows you to chose from mechanical manual or automatic change system, pneumatic system and electric (pass through) system. The Change system is mad for ease to install or uninstall the functionality you are, or are not to use. The M8 8 pin connector system can be ordered attached and installed or separately for installation at a later time when in need. The M8 8 pin connector consists of an electric unit attached to the Master (RM), and one unit attached to the Tool Holder (TH). For electric function you are to need both units to connect together.

The complete electric system is set up as a "opposite" connection system.

If the Robot has the Male connector, you are to need a Female Smartshift Master (RM) connector, then a Male Tool Holder connector. The opposite function is needed if you have a Robot with a Female connector, you are to need a Male Master connector (RM), then a Female Tool Holder connector.

When installing the electrical ad on, you are to install the units carefully for a functional fit.

When installing the Master (RM) electrical M8 8 pin ad on, you can use the supplied (or use purchased) M4 x 4 bolts added on delivery. The tightening of the M8 8 pin Master electrical unit can be tightened well. No need of controlled force.

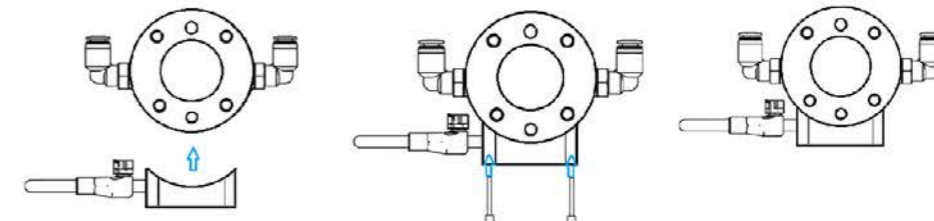

When installing the Tool Holder (TH) electrical M8 8 pin ad on, you can use the supplied (or use purchased) M4 x 4 bolts added on delivery. When tightening of the M8 8 pin Tool Holder (TH) electrical unit it is very important to NOT over tighten the bolts. The unit must be carefully tightened so that the space between the (already tightened) Master M8 8 pin connector and the Tool Holder M8 8 pin connector has a space between 1-1,5 mm of distance.

It is important to use the "crossover" tightening method (like when tightening a wheel on a car) to ensure it is not tightened unevenly, tilting or angling un aligned, but is set up even and vertical in the connection (see pic). This tightening must be done with precision and ease to make sure the connections are aligned. Smartshift encourage end users to purchase finished installed units, but in case of after installation use the following steps to be sure the connection is aligned and functional. If connection is not responding on all 8 of the M8 8 pin connections, re install the unit for an aligned installation.

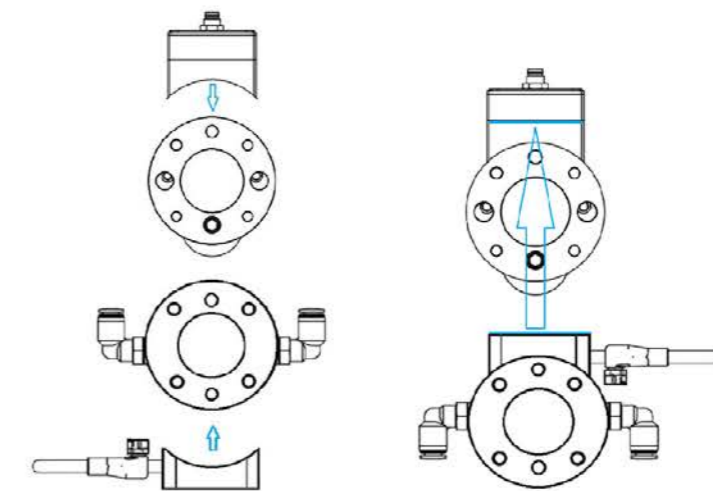
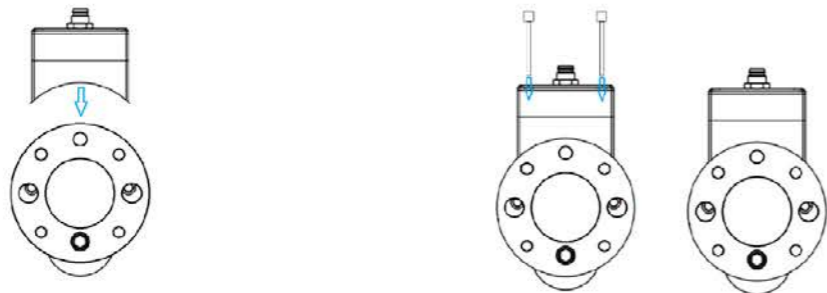

11 Aligned Installing Electrical Ad on

When installing the electrical components (ad on) the important factor of the installation is the mounting of the Tool Holder (TH) unit. Be sure to address the connection and connection bolts addressed in the manual and supplied on delivery. The connection sequence is: Male (towards) Female, or opposite. Sliding the Horizontal function, the Smartshift will now execute a perfect connect and dis connect sequence.

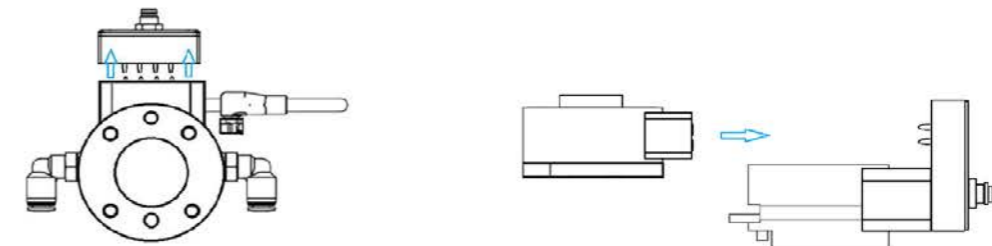

While mounting the connector ad on units, an important factor is to ensure the connection is in correct order.

Be sure to use the “car wheel phenomime” cross tightening when tightening the bolts on the Tool Holder (TH). The connection will be connecting accurate when the Master (RM) connector and the Tool Holder (TH) connector is aligned and even in its location. An important factor in this installation is also to ensure the electric connector on the Tool Holder (TH) unit is not squeezed to tight. If so, the unit connector may be tilted unevenly, creating a non-linear interaction.

If the Connection is not functional, repeat the installation, as shown below:

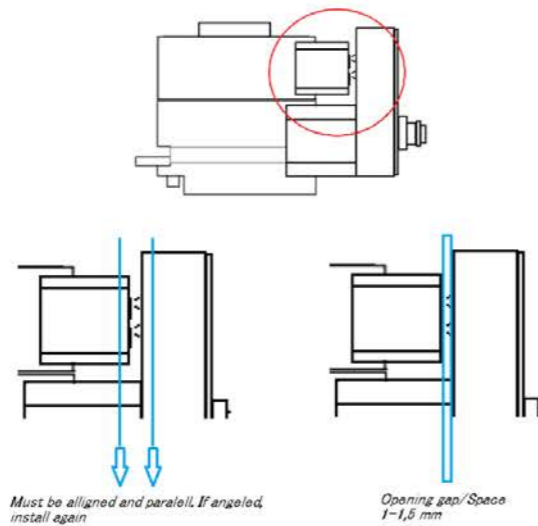

When connecting the wires on the Smartshift Tool Change system, be ware to follow the pre-installed pattern of wires for the electrical system.

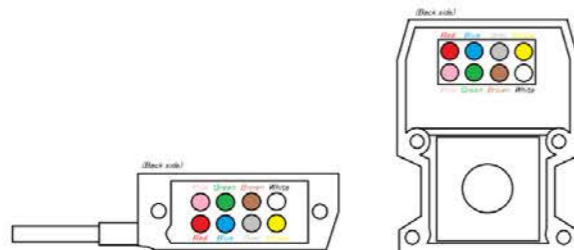

12 General usage

The Smartshift Tool Change system is made to increase the Robot and Machine usage in terms of cycle time and repetitive tasks. With the ease of use function and adaptability use of the Smartshift, covering any Robot and Machine manufacturer specification, the Smartshift Tool Change system is a system that “fits all” and modifies to any purpose and Robot type (Collaborative, Small Industrial, SCARA, Delta, +).

Tests have shown Smartshift running a Tool Change speed of 120 changes in 40 sec.

If the Robot function, adaptation, size, weight or other functionalities obstacle should accrue. Smartshift develops, manufacture, adapts and supplies all Robot needs and machine needs when it comes to multi tasking, robot application and general usage where short ROI is desired to install a Robot or machine cell.

Tests have shown Smartshift running a Tool Change cycle of 800 000 shifts and still no damage.

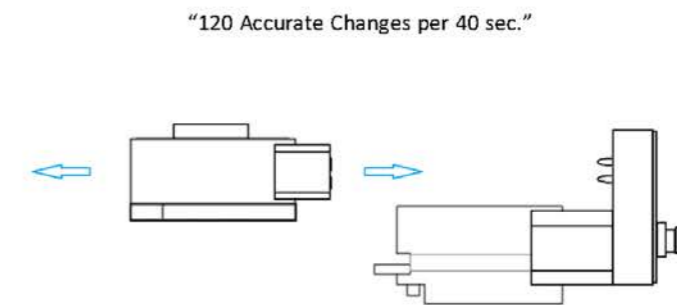

13 TCP setup

When setting up the TCP (Tool Centre Point) on your Robot, with Smartshift, use the following information.

The ToolChange system, Master (RM) + Tool Holder (TH), has a height of 65 mm total when connected together. You must then include/ad on the 65 mm when measuring from the Robot Flange and to your TCP on tool of choice (for instance a Grippers or welding torch etc.).

Weight Automatic ToolChange units

Robot Master	150 gram	(non el.)
Robot Master Electric	180 gram	
Tool Holder	255 gram	(non el.)
Tool Holder Electric	310 gram	
Manifold	110 gram	

(more specifications; www.smartshift-robotics.com, catalogue)

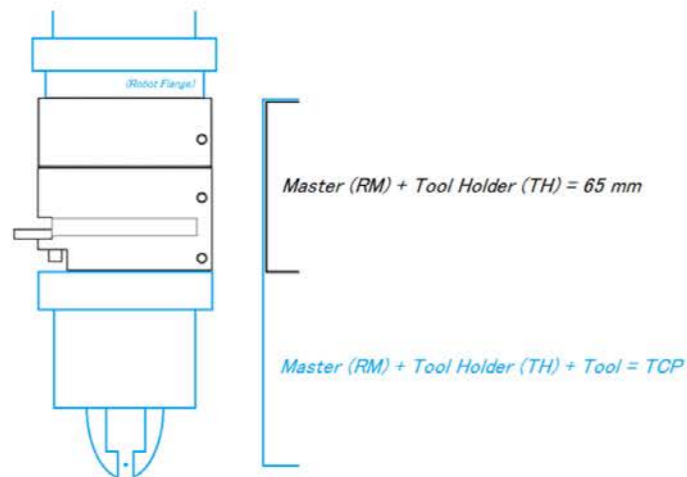

14 Running Tool Change operation – Pick up setup

Setting up a pick up and drop of the Tool Holder (TH) in to and out of the Tool Pocket (TP) is a simple operation done in minutes. By following the 3-step procedure, the setup will be secure and running correct. Key words are: Horizontally levelled Master (RM), and Vertically angled Master (RM). If the Master (RM) is tilted at an angle, pick up will not be smooth and the Robot can possibly push the Tool Holder out of the Tool Pocket (TP) under pick up move. For accurate return, Smartshift suggests to first run and log pick up direction, then copy the same way points for return and delivery.

POS. 1:

Place Robot with Smartshift Master (RM) above the backend of the Tool Pocket (TP).

POS. 2:

Lower the Robot with Smartshift Master (RM) down to the Tool Pocket, making sure the bottom end of the Master (RM) is placed a few millimetres from the cover plate of the Tool Pocket (TP).

POS. 3:

Run the Robot with the Smartshift Master (RM) horizontally and aligned straight forward through the Tool Holder (TH) that is placed in the Tool Pocket (TP) out in front of the Tool Pocket (TP).

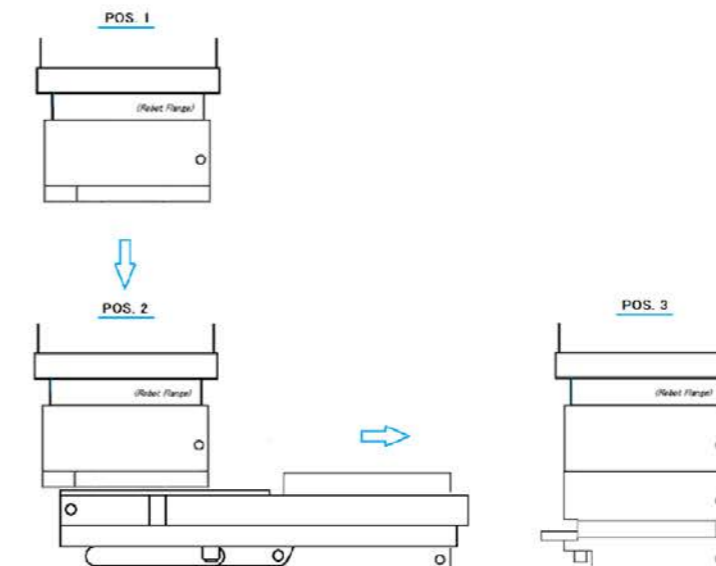



Machine name: SMARTSHIFT Clutch
 Revision: 06
 Revisions date: 2019.10.15
 Made in Norway - Original instructions - User manual

When moving from POS. 2, to POS. 3, be sure to align the Robot path both Horizontally and directly out of the Tool Pocket (TP) Vertically aligned.

Do not add another way point between POS.2 and POS.3. Smartshift Tool Change system is a mechanical system that is spring feathered tightened in the Tool Pocket (TP). To make an accurate pick up you need a one movement path going over and out of the Tool Pocket (TP). By using a one movement path between POS.2 and POS.3, the Tool Pocket (TP) (set at 5.0 Kg payload) have solved accurate pick up down to 3.0 Kg payload Robots.

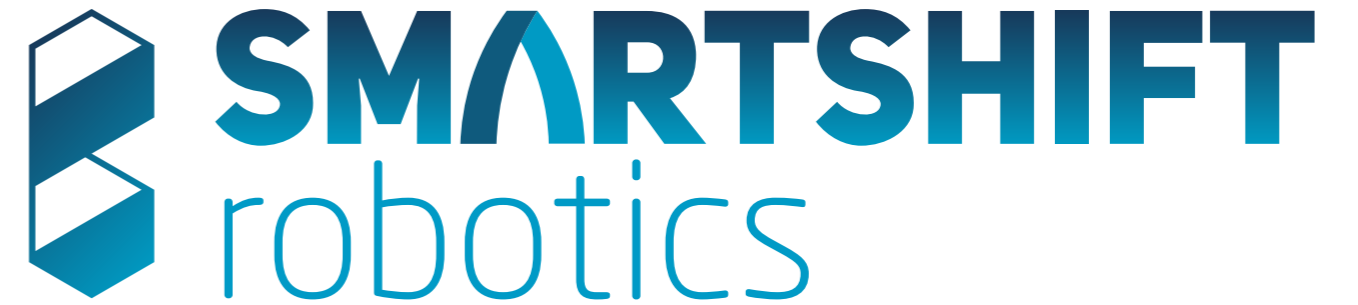
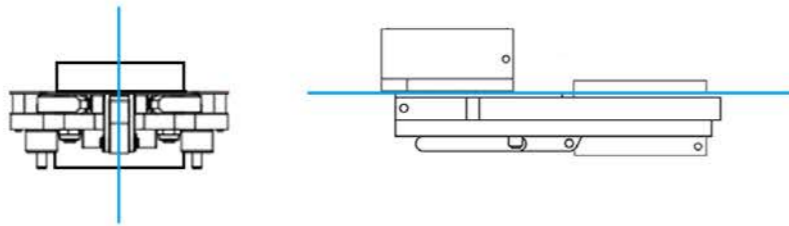

THE NEW STANDARD FOR ROBOTIC TOOL CHANGING

- 
 The patented SMARTSHIFT design and functionality provides a new standard for tool changing in the robotic industry. With universal compatibility, low weight and easy-to-connect design, SMARTSHIFT can be integrated with almost all light weight industrial and collaborative robots and tools.





SMARTSHIFT robotics

CONTACT:

Smartshift-robotics
Hensmoveien 17
3516 Hønefoss
NORWAY

COMPATIBEL WITH:

Abb - Acutronic - Aubo - Automata - Bosch -
Carbon - Comau - Denso - Dlr - Dobot - Doosan -
Elephant Robotics - Elibot - Esi - F&P Personal
Robotics - Fanuc - Festo - Flexiv - Franka Emika -
Han's Robot - Hanwha - Hitbot - Hit Robot Group -
Hyunday Robotics - Inovo Robotics - Isybot - Jaka -
Kassow Robots - Kawada Industries Inc. - Kawasaki
Robotics - Kinetic Systems - Kinova - Kuka - Life
Robotics - Mabi - Megarobo - Mip Robotics - Modbot -
Mrk-Systeme - Nachi - Neuromeka - Niryo - Omron
Techman - Pilz - Precise Automation - Productive
Robotics - Rainbow Robotics - Rethink Robotics -
Robut Technology - Rozum Robotics - Siasun -
St Robotics - Staubli - Svaya Robotics - Tokyo Robotics -
Ufactory - Universal Robots - Yaskawa - Yuanda



UR+ CERTIFIED



**DOOSAN MATE
CERTIFIED**



**WORLD WIDE
PATENT SETUP**

**NO.:
PCT/N02018/050226**