

Home of the Tiger hoisting, clamping, winching and height safety ranges

Tiger Trolley Model No. TG/TP



20t Geared Trolley



1t Geared Trolley with optional beam locking device

Main Features

- Plain Trolley Range from 0.5t to 10.0t
- Geared Trolley Range from 0.5t to 35.0t
- The anti-drop plates design ensures extra safety, and prevents damage to the wheels when contacting end rail stoppers
- Tiger trolley wheels are specially designed with a convex profile eliminating potential point loading
- The wheels run on sealed bearings for smoother rolling with less effort and maintenance
- Twin bar or single bar trolleys available
- Geared type available (with hand chain length to suit your requirements)
- Extended beam width available
- Corrosion or Spark Resistant versions available
- Operating temperature of -40°C to +80°C (temperature range of -60°C to +80°C available as an option)
- Optional beam locking device
- The 5:1 factor of safety allows for use with manual or powered hoists

If you need a wider beam range or have specific headroom requirements please contact us for bespoke solutions

These units meet and exceed all the requirements within BS EN 13157: 2004+A1:2009 and AS1418.2.

Certification:

Each unit comes fully certified with a test certificate or an EC Declaration of Conformity stating compliance with the essential health and safety requirements of the Machinery Directive 2006/42/EC.

Corrosion Resistant Trolleys

Critical components, including the hand chain and the pinion gear for geared trolleys, are protected by our unique corrosion protection finish giving unprecedented long-term reliability. Stainless steel fittings are used throughout the trolley. These ensure the initial capital outlay of purchasing a Tiger corrosion resistant trolley is protected by allowing the statutory inspections and re-certifications to be easier and also help with the overall aesthetics of the trolley being maintained in an “as new” condition. Our corrosion resistant trolleys are finished in our high quality powder coat paint offering excellent additional corrosion protection and a high degree of impact protection.

Spark Resistant Trolleys

In many areas of industry, plants are operated with potentially explosive atmospheres. Due to the very high risk to personal and other assets, extremely strict guidelines and technical requirements are in place in explosive zones. Tiger Spark Resistant products are manufactured in accordance with ATEX Directive 2014/34/EU and the Machinery Directive 2006/42/EC. Our products are lightweight and durable with a proven track record.



Smaller minimum curve ratios may be available – contact us for details

Our innovation, your safety

Home of the Tiger hoisting, clamping, winching and height safety ranges

Atex marking: Ex II 2 GD c IIC T4 IIIC T135°C. Suitable for gas and dust hazardous areas: Zone 1 & 2 (gas) and Zone 21 & 22 (dust).

- Plain or geared trolleys available
- Solid bronze trolley wheels
- Rubber buffers for trolleys
- Copper plated hand wheel (geared trolley) and hanging plate
- Special corrosion protected body
- Combination block and trolley units available



Optional

- Beam locking device

Technical Data - Plain Trolleys

	Product Code	Capacity (tonne)	D - Track width #		Dimensions (mm)										Min. curve ratio (m)	Net Weight (kg)
			Range 1 (mm)	Range 2 (mm)	A	A+	B	C	E	F	G	H	J	K		
Single Bar Trolleys	TPS-0050	0.5	62-128	62-203	195	235	106	106	98	20	64	10	24	30	0.8	5.0
	TPS-0100	1.0	62-128	62-203	213	253	113	113	106	20	71	10	27	34	1.0	7.5
	TPS-010W	1.0	106-305	N/A	236	284	210	210	132	25	80	13	38	45	1.3	TBA
	TPS-0200	2.0	88-154	88-230	236	284	136	136	132	25	80	13	38	45	1.3	12.0
	TPS-0300	3.0	87-153	88-230	275	323	146	146	150	25	97	13	42	53	1.5	19.5
	TPS-0500	5.0	106-194	106-305	323	371	169	169	174	30	117	16	46	59	1.5	30.5
Twin Bar Trolleys*	TPT-0300	3.0	87-153	88-230	320	368	142	142	82	16	110				1.5	22.0
	TPT-0500	5.0	106-194	106-305	352	400	167	166	91	24	131				1.5	35.5
	TPT-1000†	10.0	125-320	N/A	346	394	237	236	210	40	117				1.5	68.0
	TPT-1500‡	15.0	150-320	N/A	461	509	271	271	248	42‡	182				2.7	144.0

Notes:

A+ is the width with optional bumpers

B and C are minimum widths for range 1

Trolleys with locking devices will have different beam width ranges – please contact us for details.

H is the thickness of the anchor point, J is the width of the anchor point opening and K is the height of the anchor point opening.

* 0.5t-2t twin bar available as special orders – minimum order 100 each size – please contact us for details.

† We are currently changing the design of our 10t and 15t trolleys. The dimensions shown are for the new type. Please contact us for details of which types are available.

‡ A beam flange thickness up to 50mm can be accommodated if required – please ask for more information.

Please contact us for track widths outside of these ranges

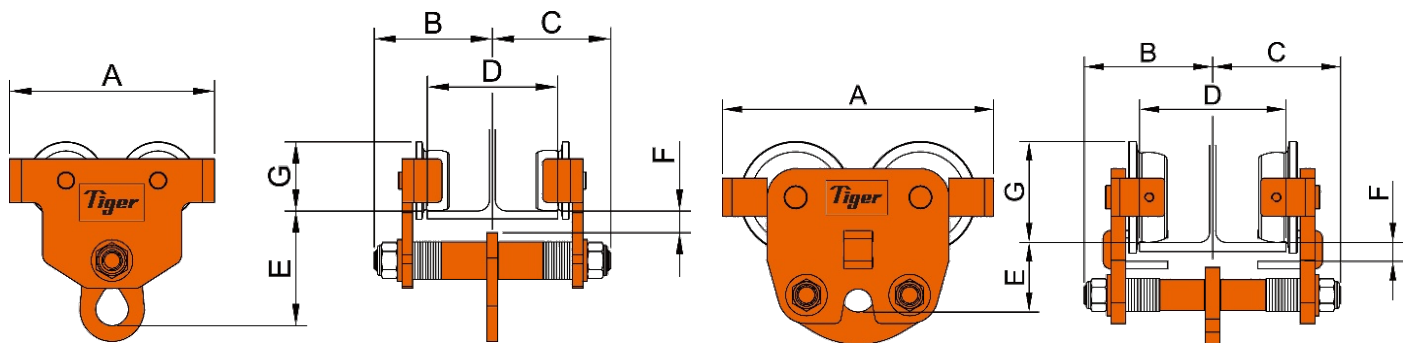

Single Bar

Twin Bar

Home of the Tiger hoisting, clamping, winching and height safety ranges

Technical Data - Geared Trolleys

	Product Code	Capacity (tonne)	D - Track width #		Dimensions (mm)										Min. curve ratio (m)	Net Weight (kg)
			Range 1 (mm)	Range 2 (mm)	A	A+	B	C	E	F	G	H	J	K		
Single Bar Trolleys	TGS-0050	0.5	62-128	62-203	195	235	180	106	98	20	64	10	24	30	0.8	9.0
	TGS-0100	1.0	62-128	62-203	213	253	180	113	106	20	71	10	28	34	1.0	11.0
	TGS-010W	1.0	106-305	N/A	236	284	269	210	132	25	80	12	38	45	1.3	TBA
	TGS-0200	2.0	88-154	88-230	236	284	193	136	132	25	80	12	38	45	1.3	16.5
	TGS-0300	3.0	87-153	87-230	275	323	198	146	150	25	97	13	42	52	1.5	24.5
	TGS-0500	5.0	106-194	106-305	323	371	216	169	174	30	117	16	46	60	1.5	35.5
Twin Bar Trolleys*	TGT-0300	3.0	87-153	87-230	320	368	194	142	82	16	110				1.5	23.5
	TGT-0500	5.0	106-194	106-305	352	400	216	166	91	24	131				1.5	40.0
	TGT-1000+	10.0	125-320	N/A	346	394	282	243	210	40	117				1.5	78.0
	TGT-1500+	15.0	150-320	N/A	461	509	338	271	248	42‡	182				2.7	161.0
	TGT-2000+	20.0	125-320	N/A	706	754	282	263	243	40‡	117	30	85	95	6.0	160.0
	TGT-2500+	25.0	125-320	N/A	706	754	282	263	243	40‡	117	35	100	115	6.0	170.0
	TGT-3000+	30.0	150-320	N/A	961	1009	335	263	274	42‡	182	35	100	115	6.0	337.0
	TGT-3500+	35.0	150-320	N/A	961	1009	335	280	274	42‡	182	38	100	115	6.0	341.0

Notes:

Standard geared trolley hand chain length – 2.5m. We can change the length to suit your requirements.

A+ is the width with optional bumpers

B and **C** are minimum widths for range 1

Trolleys with locking devices will have different beam width ranges – please contact us for details.

H is the thickness of the anchor point, **J** is the width of the anchor point opening and **K** is the height of the anchor point opening.

* 0.5t-2t twin bar available as special orders – minimum order 100 each size – please contact us for details.

+ We are currently changing the design of our 10t plus trolleys. The dimensions shown are for the new type. Please contact us for details of which types are available.

‡ A beam flange thickness up to 50mm can be accommodated if required – please ask for more information.

Please contact us for track widths outside of these ranges

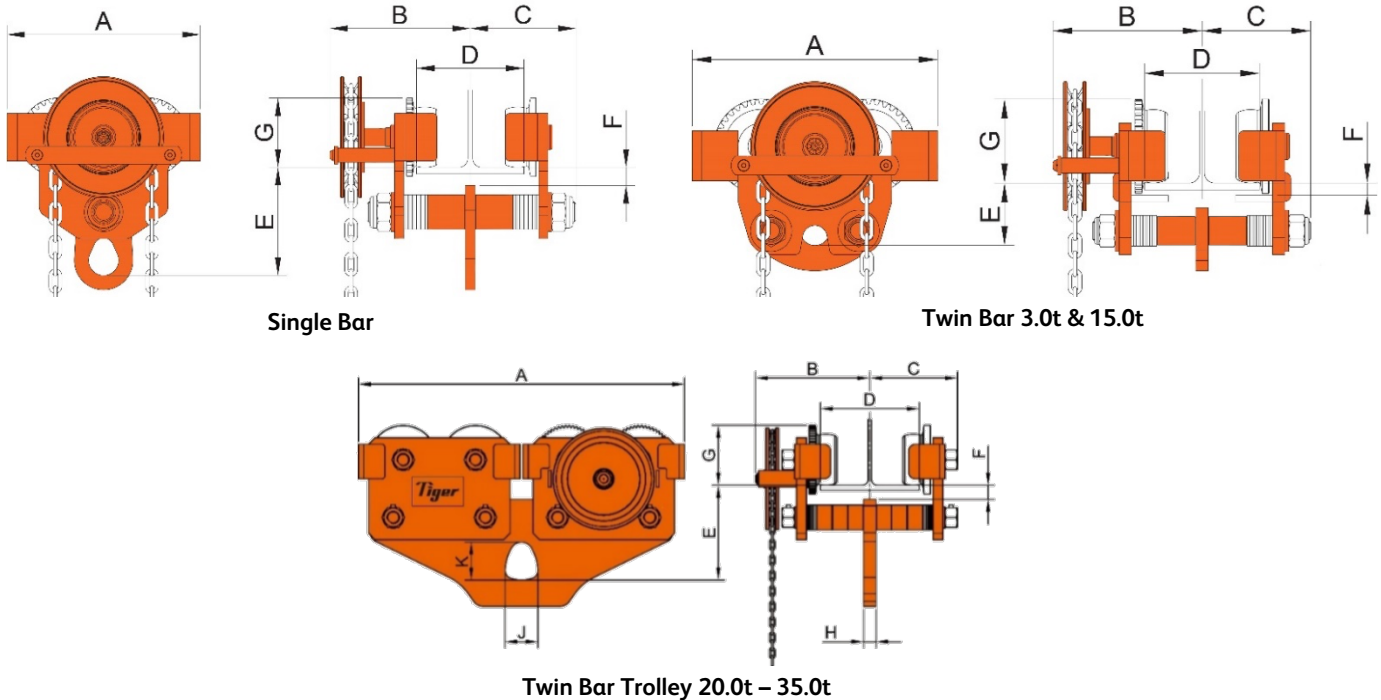

Due to our policy of continual product development, dimensions, weights and specifications may change without prior notice.