



## Scissor pallet truck with manual-hydraulic lift or electric-hydraulic lift option

**Capacity: 1000kg    Fork height: 800mm**

A combination of hand pallet truck and elevating platform for the transport and raising of palletised loads to various departments. Manual and electric options are available.

### HU HS 10 B (Manual/hydraulic lift) features:

- Safety control handle with the functions:
  - Quick lift - lifting - lowering -
- Lowering speed can be finely metered for sensitive lowering of the load.
- One-stage hydraulic for increased robustness.
- Quick lift for loads up to 250kg.
- Overload protection by pressure relief valve.
- Safety supports guarantee sure standing when the forks are raised.
- Low noise and smooth running with standard tyres: steer rollers and load rollers - polyurethane.

### HU ES 10 B (Electric/hydraulic lift) features:

- Increases the usefulness of the HU HS 10 A by saving operating time for demanding applications with frequent lifting and lowering operations.
- Ergonomic control button for the hydraulic unit fitted in the handle.
- In the case of battery failure the manual use of lifting and lowering is still guaranteed.
- Quick electric-hydraulic lifting of the load, pressure relief valve protects against overloading.
- Low noise and smooth running due to polyurethane steering and load rollers as standard.
- Additional tilting protection for the load rollers.
- Comes complete with battery and battery charger.

Model			HU HS 10 B	HU ES 10 B
Article no.			N26600020	N26900020
Lift capacity	Q	kg	1000	1000
Load centre	c	mm	600	600
Weight		kg	122	152
Tyre type**			PUR/PUR	PUR/PUR
Steering rollers		mm	180 x 50	180 x 50
Load rollers		mm	75 x 50	75 x 50
No. of wheels/load rollers			2 / 2	2 / 2
Stroke	h3	mm	715	715
Max. height of handle	h14	mm	1254	1254
Fork height lowered	h13	mm	85	85
Overall length	l1	mm	1725	1715
Overall width	b1/b2	mm	575	575
Fork height	s	mm	45	45
Fork width	e	mm	160	160
Fork length	l	mm	1170	1170
Outside fork dimension	b5	mm	540	540
Ground clearance	m2	mm	18	18
Aisle width pallet	Ast	mm	1986	1986
Turning circle radius	Wa	mm	1564	1564
Battery charger	V/A		-	220 / 6
Battery voltage, capacity	k5	V/Ah	-	12 / 52

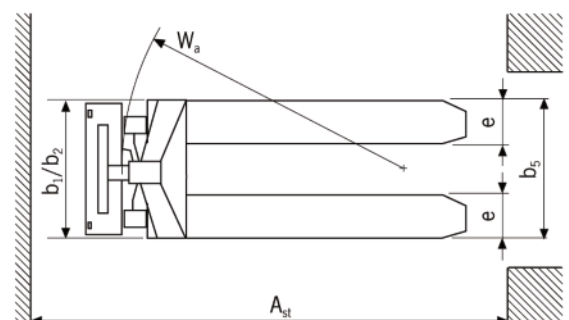
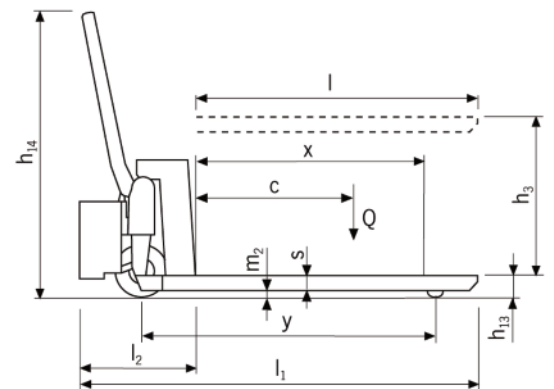

\*\*Polyurethane (PUR).