

EGU PS 14 ELECTRIC PALLET TRUCKS

EGU PS 14, 'Heavy duty' electric pallet truck Capacities: 1400kg

Pfaff offer a range of multi-purpose, heavy duty, electric pallet trucks for professional lifting tasks up to 1400kg. These units are robustly constructed, comfortable to drive and steer, and can operate in tight spaces given their compact housing chassis. The EGU PS 14 range really is designed for the professional user and is ideal for working on ramps and for loading/unloading container lorries.

EGU PS 14 Basic - Entry level model with DC traction motor.

EGU PS 14 Plus - Uses the maintenance friendly AC traction motor for longer working periods.

EGU PS 14 Li-ION - Uses Li-ION battery which has a lifespan of upto 3000 charging cycles.

Features and benefits include:

- Multifunctional control handle for easy handling. The electric pallet lift truck will automatically be slowed down if the control handle in the operators hand.
- Impulse control for stepless regulation of driving speed.
- Slow moving function at upright handle position for the use in confined spaces.
- Battery size depends on the type of application.
- Anti-crush safety device on handle.

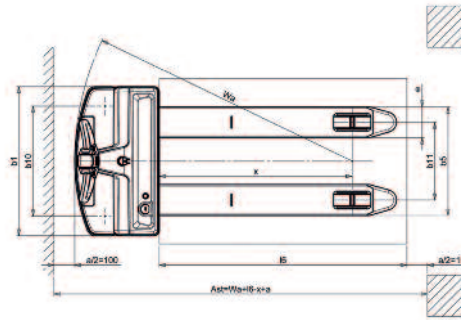
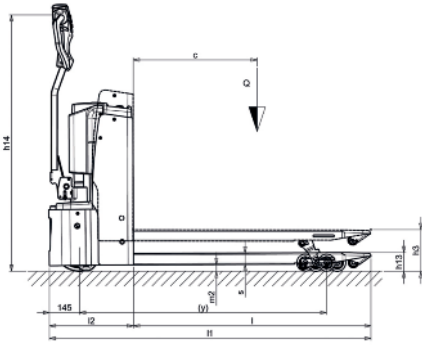

Type			EGU PS 14 Basic	EGU PS 14 Plus	EGU PS 14 <i>Li-ION</i>
Article no.			192062096	192062097	192062098
Lifting capacity	kg		1400	1400	1400
Drive			Electric	Electric	Electric
Load centre	mm	c	600	600	600
Tyre type*	-		VG/PUR	VG/PUR	VG/PUR
Steering rollers	mm		250 x 76 + 100 x 40	250 x 76 + 100 x 40	250 x 76 + 100 x 40
Load wheels	mm		82 x 80	82 x 80	82 x 80
Stroke	mm	h3	115	115	115
Fork height, maximum	mm	h15	200	200	200
Steering handle height	mm	h14	1230	1230	1230
Fork height lowered	mm	h13	85	85	85
Total unit length	mm	L1	1560	1560	1560
Outside fork width	mm	b1	525	525	525
Fork width	mm	e	150	150	150
Useable fork length	mm	l	1150	1150	1150
Aisle width pallet	mm	Ast	1810	1810	1810
Turning circle radius	mm	Wa	1345	1345	1345
Travel speed with/without load	km/h		4.4/4.8	6.0/6.0	6.0/6.0
Lowering speed with/without load	m/s		0.05/0.04	0.05/0.04	0.05/0.04
Gradient with/without load	%		5/10	5/10	5/10
Battery			Starter	AGM	Li-ION
Battery voltage	V/Ah		24/70	24/85	24/50
Weight (with battery)	kg		227	256	212

*Polyurethane (PUR), Solid Rubber (VG).