

EGU 15E *Li-ION* ELECTRIC PALLET TRUCK

**NEW
MODEL**

EGU 15E *Li-ION* electric pallet truck Lifting capacity 1500kg

Ideal for internal transport of palletised goods on even ground, covering short to medium distances. The EGU 15 E is the new generation of electric pallet trucks. With its compact dimensions and new Lithium battery, it is an ideal alternative to the standard pallet truck and, with only 123 kg service weight the perfect driving device on a truck.

Supplied as standard with a replaceable battery the discharged battery can be exchanged with a fully charged battery within seconds, minimising the amount of disruption to the work cycle. Charging time for the battery is only 2.5 hours.

Features and benefits include:

- Maintenance-free rechargeable Lithium battery.
- Integrated Battery management system controls all important parameters and performance of the lithium battery.
- Charging time of only 2.5 hours, intermediate charge is possible.
- Integrated PIN code panel with LCD display.
- Curtis-Controller and CAN-Bus technology.
- Infinitely variable driving speed.
- External battery charger for charging with a 230 V plug socket.
- Battery charge indicator and operating hour counter.
- Entry rollers ensure smooth entry into bottom-boarded pallets.

Scope of delivery:

- Maintenance free rechargeable Lithium battery 24 Volt/20 Ah (30 or 36 Ah as option)
- External charger

Type	EGU 15E <i>Li-ION</i>		
Article no.	N23315461		
Lifting capacity	kg		1500
Weight (with battery)	kg		123
Load centre	mm	c	600
Tyre type*	-		PUR / PUR
Steering rollers	mm		210 x 70
Load wheels	mm		80 x 93
Stroke	mm	h3	115
Height of control handle	mm	h14	1160
Fork height lowered	mm	h13	85
Total unit length	mm	L1	1530
Overall width	mm	b1	540
Fork width	mm	e	160
Useable fork length	mm	l	1150
Aisle width pallet	mm	Ast	2000
Turning circle radius	mm	Wa	1330
Travel speed with/without load	km/h		4.6/4.8
Lowering speed with/without load	m/s		0.020/0.025
Gradient with/without load	%		5/10
Battery voltage	V/Ah		24/20
Battery weight	kg		30

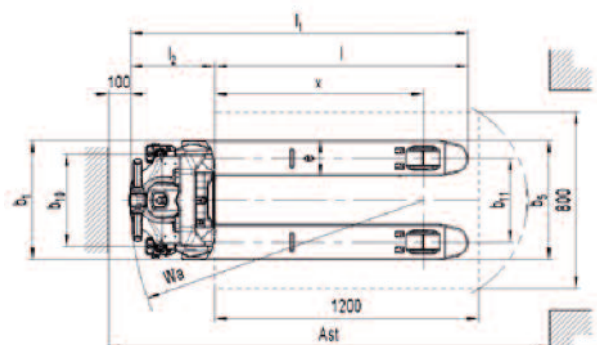
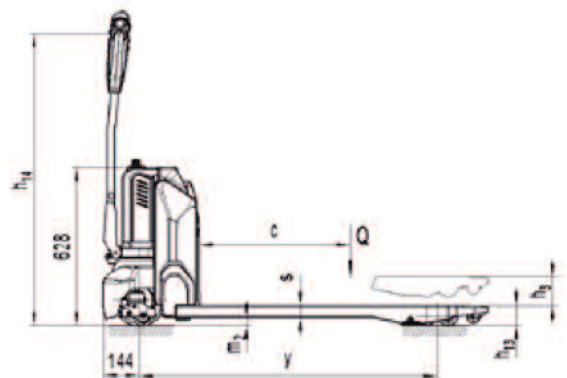

*Polyurethane.