

MODEL: RS20-03, 30-06 & 60-10

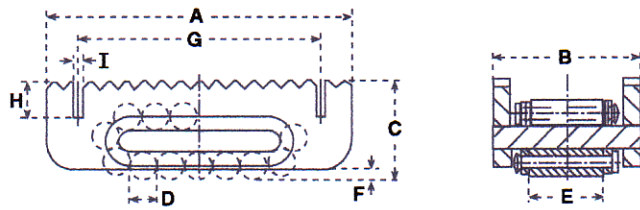

MODEL: RS30 & 40

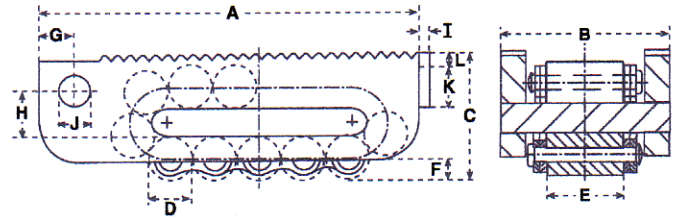

Model	Capacity tonnes	A mm	B mm	C mm	D mm	E mm	F mm	G mm	H mm	i mm	j mm	k mm	l mm	No. Rollers	Weight kgs
RS20-03	5	205	102	62	18	51	7	166	26	8	n/a	n/a	n/a	15	5.5
RS30-06	7.5	215	112	74	24	58	11	178	26	8	n/a	n/a	n/a	13	7.5
RS60-10	15	268	130	92	30	66	13	218	26	8	n/a	n/a	n/a	13	13
RS30	30	380	168	125	42	76	16	36	48	10	31	40	15	13	35
RS40	40	530	182	145	50	86	19	36	60	10	31	40	15	17	65

MODEL: RTT 20, 30 & 60

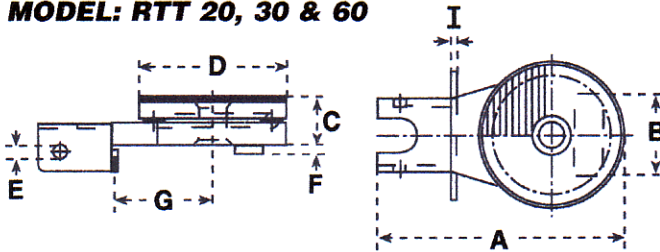

MODEL: TTR 30 & 40

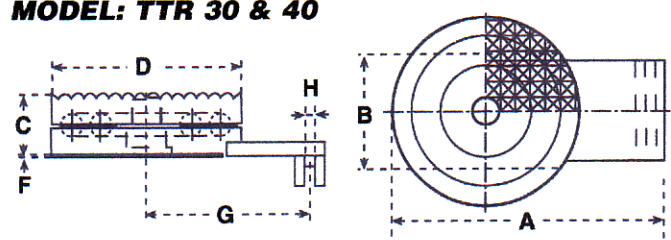

Model	Capacity tonnes	A mm	B mm	C mm	D mm	E mm	F mm	G mm	i mm	Weight kgs
RTT20	5	220	73	41	128	10.5	8	88	5	4.5
RTT30	7.5	220	85	41	128	10.5	8	88	5	4.5
RTT60	15	250	95	48	150	10.5	8	107	5	6.7
TTR30	30	275	114	62	190	N/A	3	165	12	13.7
TTR40	40	360	128	62	220	N/A	3	235	12	18.9

MODEL: RPP20, 30 & 60

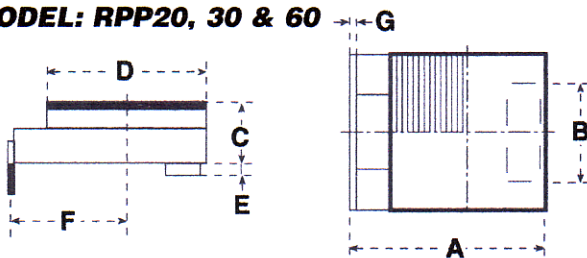

MODEL: PP30 & 40

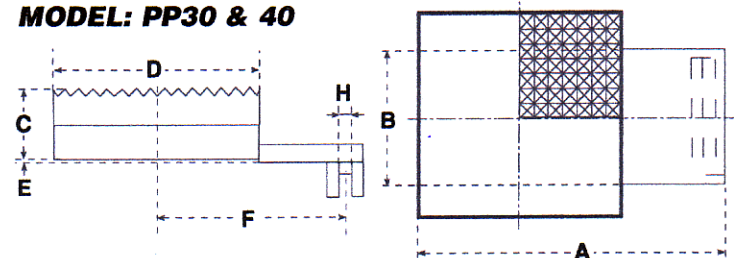

Model	Capacity tonnes	A mm	B mm	C mm	D mm	E mm	F mm	G mm	i mm	Weight kgs
RPP20	5	150	73	41	120	8	88	5	N/A	3.7
RPP30	7.5	150	83	41	120	8	88	5	N/A	3.7
RPP60	15	175	95	48	130	8	105	5	N/A	3.7
PP30	30	270	114	62	180	3	165	N/A	12	13.8
PP40	40	350	128	62	200	3	235	N/A	12	18.8

STEERMAN
LOAD MOVING SYSTEMS

TECHNICAL SPECIFICATION

Model: RS20-03, 30-6, 60-10

Description: Replacement Skate units for SCS Kits

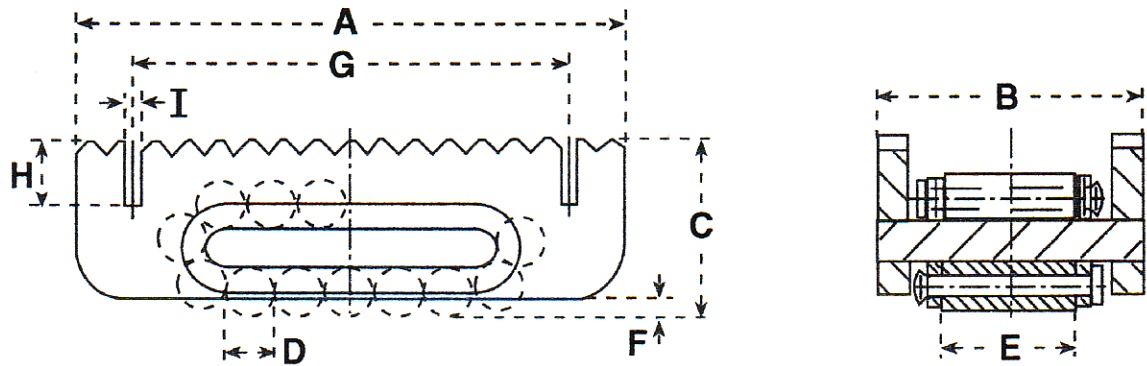

Model	Capacity tonnes	A mm	B mm	C mm	D mm	E mm	F mm	G mm	H mm	i mm	j mm	k mm	l mm	No. Rollers	Weight kgs
RS20-03	5	205	102	62	18	51	7	166	26	8	n/a	n/a	n/a	15	5.5
RS30-06	7.5	215	112	74	24	58	11	178	26	8	n/a	n/a	n/a	13	7.5
RS60-10	15	268	130	92	30	66	13	218	26	8	n/a	n/a	n/a	13	13

“Moving Loads the Professional Way!”

STEERMAN
LOAD MOVING SYSTEMS

TECHNICAL SPECIFICATION

Model: RTT20,30 & 60

Description: 20, 30 & 40 tonne capacity, Caterpillar Skate Turntables

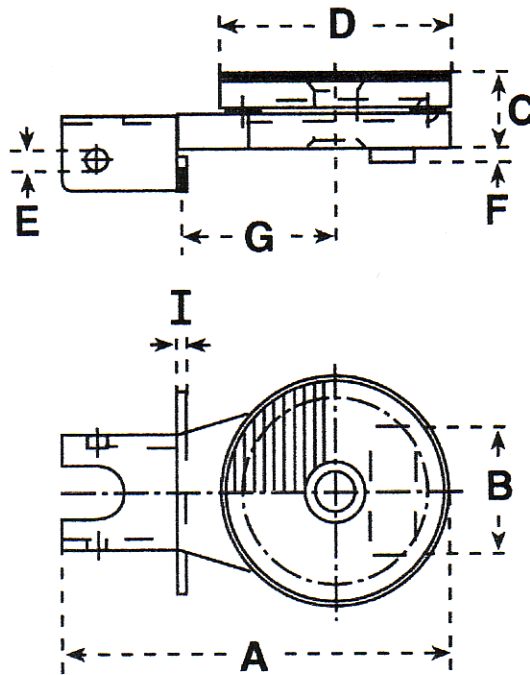

Model	Capacity tonnes	A mm	B mm	C mm	D mm	E mm	F mm	G mm	i mm	Weight kgs
RTT20	5	220	73	41	128	10.5	8	88	5	4.5
RTT30	7.5	220	85	41	128	10.5	8	88	5	4.5
RTT60	15	250	95	48	150	10.5	8	107	5	6.7

“Moving Loads the Professional Way!”

STEERMAN®

LOAD MOVING SYSTEMS

TECHNICAL SPECIFICATION

Model: RS30 & RS40

Description: 30 and 40 tonne capacity, Caterpillar Skate

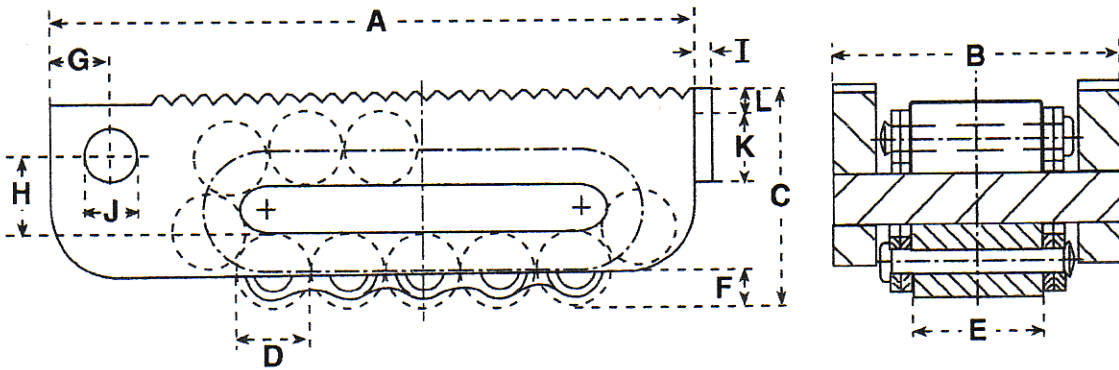

Model	Capacity tonnes	A mm	B mm	C mm	D mm	E mm	F mm	G mm	H mm	i mm	j mm	k mm	l mm	No. Rollers	Weight kgs
RS30	30	380	168	125	42	76	16	36	48	10	31	40	15	13	35
RS40	40	530	182	145	50	86	19	36	60	10	31	40	15	17	65

“Moving Loads the Professional Way!”

STEERMAN®

LOAD MOVING SYSTEMS

TECHNICAL SPECIFICATION

Model: TTR-30 & 40

Description: 30 & 40 tonne capacity, Caterpillar Skate Turntables

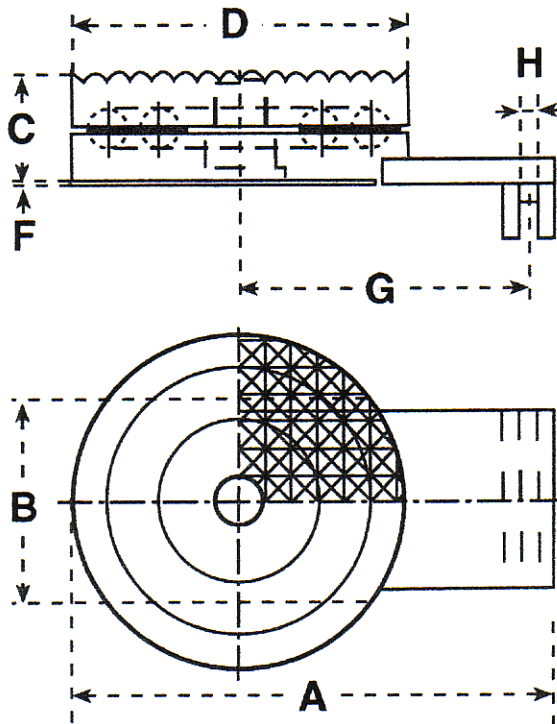

Model	Capacity tonnes	A mm	B mm	C mm	D mm	E mm	F mm	G mm	H mm	Weight kgs
TTR30	30	275	114	62	190	n/a	3	165	12	13.7
TTR40	40	360	128	62	220	n/a	3	235	12	18.9

“Moving Loads the Professional Way!”

STEERMAN®

LOAD MOVING SYSTEMS

TECHNICAL SPECIFICATION

Model: PP30 & 40

Description: 30 & 40 tonne, Caterpillar Skate - Packing Plates

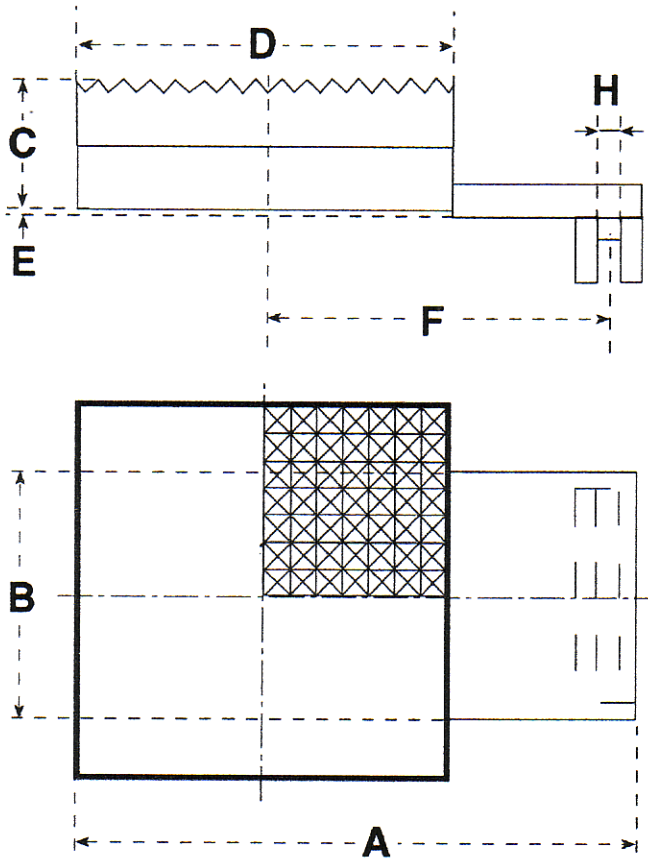

Model	Capacity tonnes	A mm	B mm	C mm	D mm	E mm	F mm	G mm	H mm	Weight kgs
PP30	30	270	114	62	180	3	165	n/a	12	13.8
PP40	40	350	128	62	200	3	235	n/a	12	18.8

“Moving Loads the Professional Way!”

STEERMAN
LOAD MOVING SYSTEMS

TECHNICAL SPECIFICATION

Model: RPP20,30 & 60

Description: 20, 30 & 60 tonne, Caterpillar Skate - Packing Plates

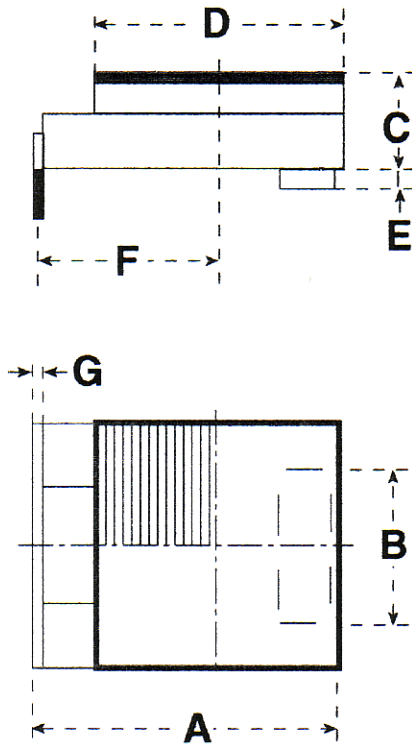

Model	Capacity tonnes	A mm	B mm	C mm	D mm	E mm	F mm	G mm	H mm	Weight kgs
RPP20	5	150	73	41	120	8	88	5	n/a	3.7
RPP30	7.5	150	85	41	120	8	88	5	n/a	5.3
RPP60	15	175	95	48	130	8	105	5	n/a	13.8

“Moving Loads the Professional Way!”