



Suitable for use in a multitude of industries, our forklift tipping skips help keep working areas clear and allow safe and speedy removal of scrap or rubbish to the appropriate waste receptacle or collection point

Manufactured from heavy duty 5mm gauge steel

Model Ref	Volume Capacity (m ³)	Load Capacity (kg)	Weight (kg)
RFS 40L-HD	0.40	1000	172
RFS 80L-HD	0.80	1000	236
RFS 120L-HD	1.20	1250	270
RFS 160L-HD	1.60	1500	321
RFS 200L-HD	2.00	1500	395

Features & Benefits

- Full width release handles eliminates need to lean in between the skip and truck mast
- Heavy duty steel underframe offering long service life properties
- Twin locking mechanism for added safety to ensure skip is locked if loaded unevenly
- Pre-drilled castor plates for retro fitment of castors (no welding required)
- Safety security chain to ensure safe retention to forklift truck
- Bolted tipping handle for easy replacement (no welding required)

Skips can be colour coded to adhere to stringent and environmental policies



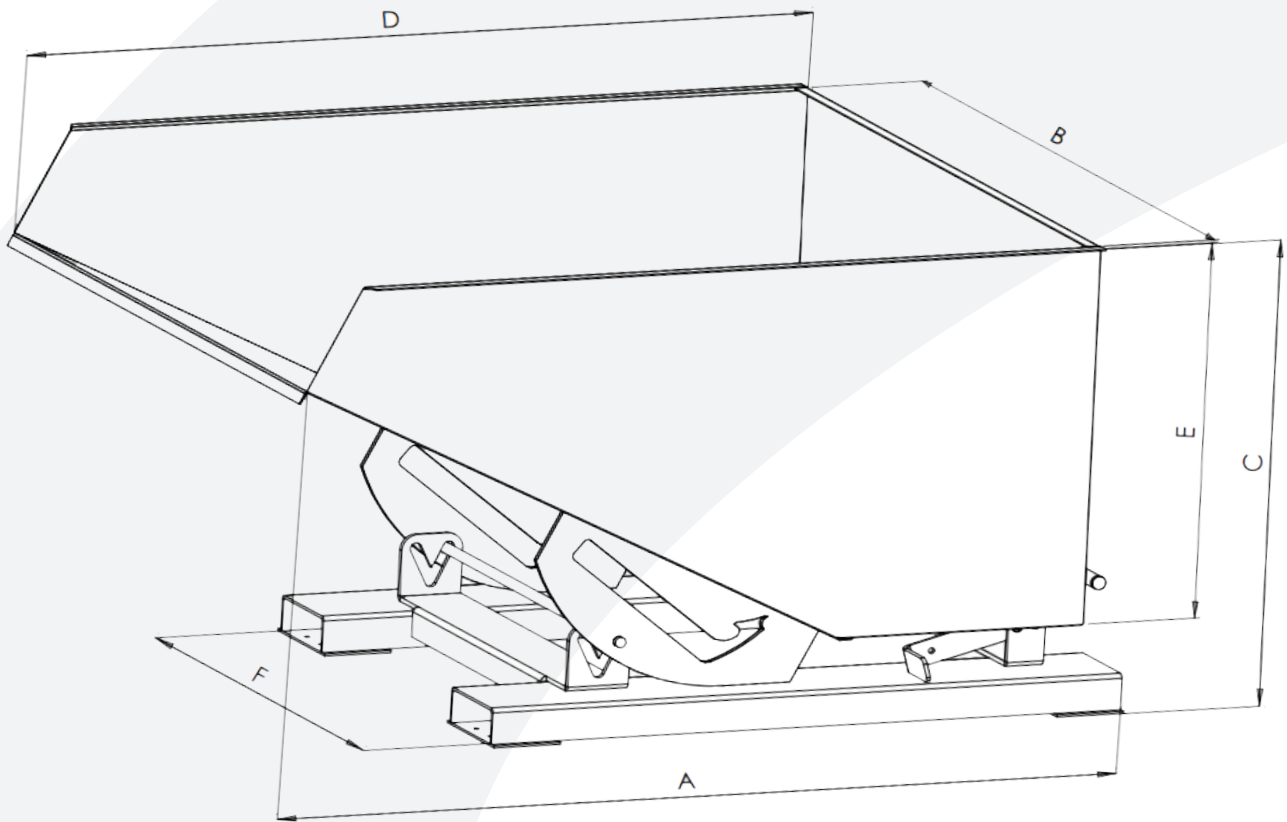

Maximum Fork Section 150mm x 60mm

Model Ref	O/all Length A (mm)	Bin Width B (mm)	O/all Height C (mm)	Bin Length D (mm)	Bin Height E (mm)	Fork Spread F (mm)
RFS 40L-HD *	1360	794	776	1197	547	890
RFS 80L-HD	1718	960	982	1540	750	890
RFS 120L-HD	1718	1300	982	1540	750	890
RFS 160L-HD	1718	1700	982	1540	750	890
RFS 200L-HD	1718	2125	982	1540	750	890

* For the RFS 40L-HD model, please note the overall width is 925mm. For all other models, the bin width (dimension B) is the widest point