

Guerrilla  
Gravity

# TRAIL PISTOL

Owner's Manual

11

# Contents

- Assembly
  - Frame fittings
  - Fastener torque
  - Fork compatibility
  - Drivetrain compatibility
  - ISCG Mount
- Setup
  - Fork
  - Shock install & orientation, air springs vs coil springs
  - Suspension sag, air volume spacers, and damper settings
- Crush Mode/ Plush Mode
- Onboard Frame Storage
- Maintenance and Small Parts
- Safety

# Assembly - Frame Fittings

- Headset: EC49/40 lower, ZS49/28 for tapered steer tube
- BB: Standard 73mm BSA threaded
- Seat post:  $\varnothing 30.9\text{mm}$ , Clamp:  $\varnothing 34.9\text{mm}$ , stealth routing compatible
- Rear hub: 12x148, offset 3mm to the drive side
- Rear brake mount: International Standard
- Shock: 210x50, 8x25 front, 8x40 rear hardware
- Tires: Up to 29x2.6" or 27.5x3.0"
- Chainring: Up to 34 teeth, 55mm chainline

# Assembly – Fastener Torque

1. Main Pivot Axle
  1. Adjust pre-load on angular contact bearings (8mm hex)
  2. Then tighten pinch bolt to 10 Nm (7 lb-ft, 90 in-lb) (5mm hex)
2. Rocker Pivot Axle
  1. Adjust pre-load on angular contact bearings (5mm hex)
  2. Then tighten pinch bolt to 10 Nm (7 lb-ft, 90 in-lb) (5mm hex)
3. Seatstay/Rocker Bolts: 7 Nm (5 ft-lb, 65in-lb) (5mm hex)
4. Chainstay/Axle Block Bolts: 7 Nm (5 ft-lb, 65in-lb) (5mm hex)



# Assembly – Fastener Torque

## 1. Rear Axle

1. Pinch bolt holds axle nut insert and derailleur hanger, ***to remove rear wheel, only loosen axle head***

## 2. Derailleur Hanger

1. The pinch bolt clamps the nut insert and attaches the derailleur hanger
2. Tighten pinch bolt to 10 Nm (7 lb-ft, 90 in-lb) (5mm hex)
3. **Do not loosen pinch bolt to remove rear wheel**



# Assembly - Chainline

Definition: Distance between frame centerline plane and center plane of chainring

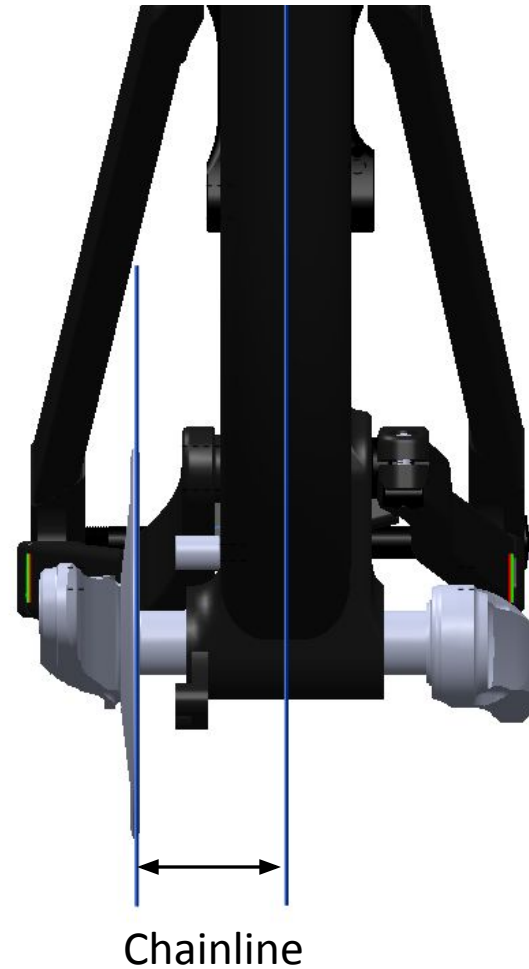

# Assembly - Chainline

RaceFace Cranks – 55mm Chainline

134mm Spindle

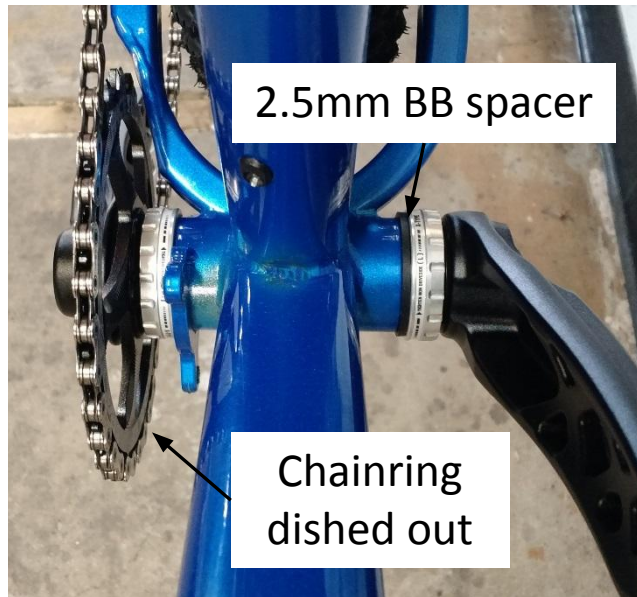

143mm "Plus" Spindle

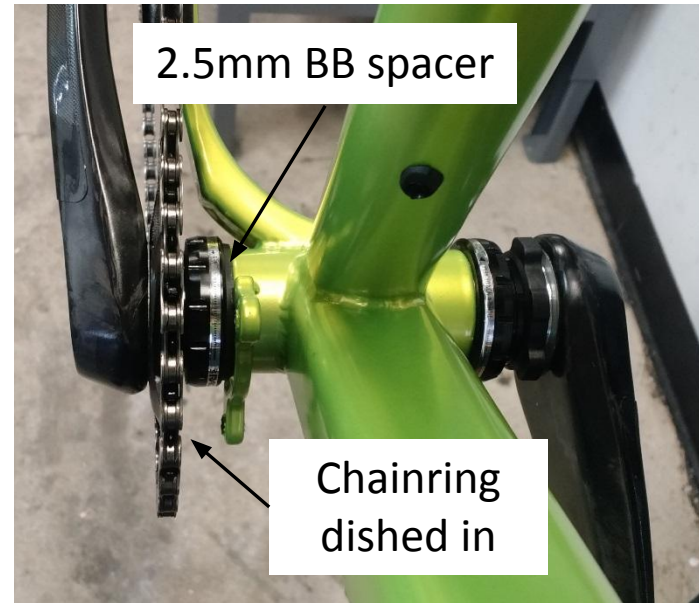

## Notes:

- Pedälhead frame shown for clarity, setup is the same for the Trail Pistol
- For Sram cranks, use a 0mm offset chainring and install per normal method

# Assembly - Chainline

Shimano Boost Cranks – 55mm Chainline

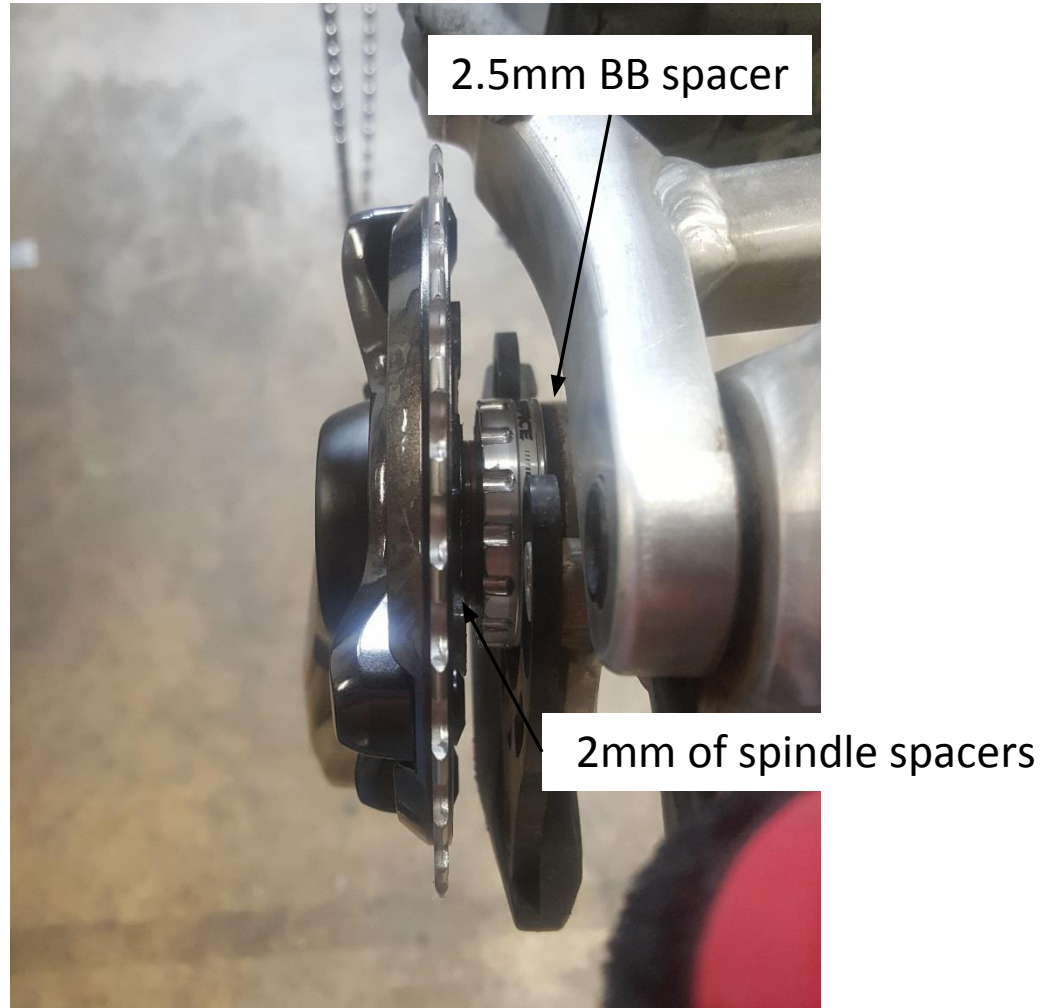



# Assembly - Rear Hub Offset

12x148 Rear Hub, Offset 3mm to the Drive Side

6mm Spacer on Non Drive Side

True Wheel With 6mm Spacer

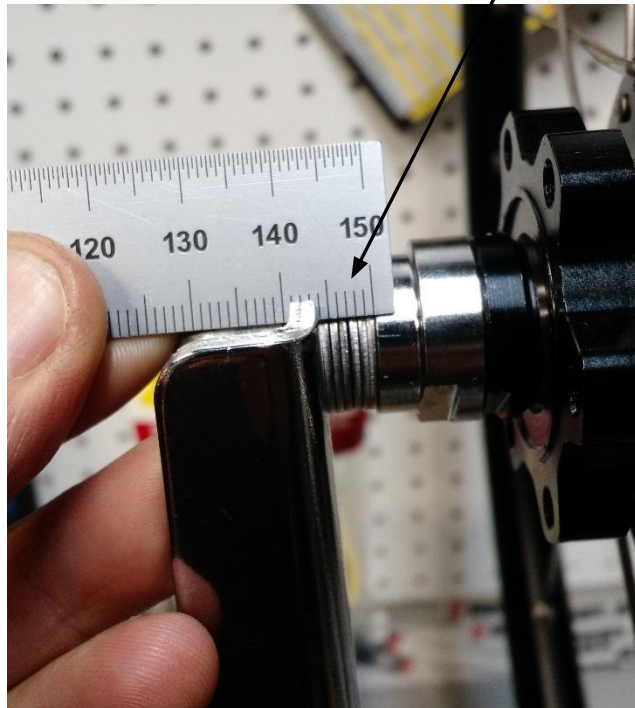

6mm spacer



Center rim

Note: You *do* need to use a 6mm spacer on a traditional truing stand to offset the hub 3mm.

# Assembly - ISCG Mount

The Trail Pistol has an ISCG05 mount for a chainguide and/or bash guard. The upper bolt and mount spacer is included with the frame; install as shown.



# Compatibility – Shock & Fork

1. Install Both Shock Bolts Before Tightening, Torque Spec: 7 Nm
2. What Type of Rear Shocks Are Compatible?
  1. Most modern 210mm eye to eye x 50mm stroke length air sprung and coil sprung shocks are compatible. Piggy back style shocks are compatible in most cases
3. Compatible Fork Sizes:
  1. Axle to crown height of 531mm – 551mm; eg Rockshox Pike 29/27.5+ and MRP Stage 120mm – 140mm travel.





# Setup – Sag, Air Volume, Dampers

## 1. Spring Recommendations

1. The Trail Pistol is optimized for modern air springs with large volume negative chambers, such as the Rockshox Deluxe/Super Deluxe with Debonair, as well as coil springs
2. Bottom out resistance can be tuned with air volume spacers independent of sag

## 2. Sag Recommendations

1. Sag numbers are obtained by measuring the suspension travel used to statically support your weight, geared up to ride.
2. To measure sag, set the damper settings relatively soft, sit on the bike in climbing position, with the seatpost at full height, naturally weight the handlebars. This method produces the most usable and repeatable measurements.
3. Lightly bounce up and down to break any seal stiction, return to the seated climbing position and push the fork and shock O-rings against the shock/fork seals. Lean to the side to dismount without further compressing the suspension.
4. Measure the shock/fork travel used to support your weight
5. Front sag recommendation: 15% = 19mm on a 130mm travel fork
6. Rear sag recommendation: 25% - 27% = 12-14mm on the Trail Pistol
  1. **25% sag with 2 Bottomless Tokens in a Rockshox Deluxe/Super Deluxe produces a more traditional “trail/xc” feel that is stiffer in the top half of the stroke**
  2. **27% sag with 3 Bottomless Tokens in a Rockshox Deluxe/Super Deluxe produces a more “all mountain” feel optimal for more aggressive riding and better small bump compliance**

## 3. Damper Settings

1. The spring supports your weight, and should be optimized first
2. Compression damping then controls dive speed. Insufficient compression damping makes the bike dive too easily under braking and feel unstable in hard cornering. Excessive compression damping diminishes small bump compliance and makes the wheel deflect off obstacles.
3. Rebound damping controls how fast the suspension returns from being compressed. In general, the fastest rebound setting that doesn't allow wallowing works best. Rebound damping is a function of spring stiffness, so if spring rate is increased, rebound damping will need to be proportionally increased as well.

## 4. Tuning

1. Suspension settings are iterative and personal for different terrain and rider weights and riding styles
2. Baselines are meant to be exactly that. Further tuning is encouraged to refine the ride for you and your terrain. Feel free to ask us for advice: [Bikes@RideGG.com](mailto:Bikes@RideGG.com)

# Crush Mode & Plush Mode

## Crush Mode



Using the upper rear shock hole location, this mode is optimized for going as fast as possible on 29" wheels; this mode has a more slack head angle and more bottom out resistance in the rear suspension.

27.5+ wheels can be used in Crush Mode for aggressive riding on the wider tires with a lower bottom bracket height.

Plush Mode utilizes the lower rear shock hole location and is optimized for 27.5+ wheels, as they have a slightly smaller diameter than 29ers and are most often used for less aggressive riding. This mode brings the bottom bracket height up to the same height as a 29er in Crush Mode, steepens the head angle  $0.8^\circ$  and tunes the suspension for less aggressive riding.

29" wheels can be used in Plush Mode for those looking for faster steering and more pedal clearance.

## Plush Mode





## Onboard Frame Storage – Water Bottle

The Trail Pistol is equipped with a water bottle mount in the front triangle for maximum versatility. Note that not all water bottle cages or water bottles will fit, as there are no standards for where the cage mount screws are located relative to the bottom of the water bottle. The cage and bottle available from Guerrilla Gravity has been optimized for the best fit, but in general, side mount bottle cages and 21oz water are compatible.





## Onboard Frame Storage – NUTS

For the **Necessities Under The Saddle**, the Trail Pistol is equipped with a mount for the optional NUTS kit. This kit is available from Guerrilla Gravity and includes a custom made strap with a high friction coating, and flat tire repair kit.

Make sure to roll the inner tube compactly, strap everything in tightly, avoid allowing any metal part to contact the bicycle frame, and check the system for a secure attachment after a proper thrashing. If you prefer more security, you may consider putting the flat repair items in a small sack.



# Maintenance

## 1. Every Ride Checklist

1. Check for loose bolts. This does not mean to over-tighten the bolts every ride. Check to see if any bolts have loosened, and if so, then retighten them to the torque specs provided in this manual.
2. Check the brakes for proper operation
3. Check tire pressure
4. Clean and lube the chain and drivetrain
5. Make sure your headset is tight by holding the front brake and rocking the bike back and forth and feeling for play or slop at the headtube, headset bearing cup junction
6. Clean all stanchions, including the fork, shock and dropper post.

## 2. Every 10 Rides Checklist

1. Check to make sure your brake pads have sufficient pad material left, replace if they are close to being worn down to the metal base
2. Make sure your tires are safe to ride on. Look for damaged casings, knobs are still in tact, and there is no dry rotting.
3. Check chain wear. Bike shops have a tool to measure this, if the wear is beyond 75% of the usable range, replace it.
4. Check spoke tension for both wheels. If a spoke is loose, tighten it so that it's tension is uniform with the other spokes.

## 3. Every 20 Rides Checklist

1. Clean frame and check for damage or cracks
2. Replace shifter cable and housing
3. Check brakes, suspension and dropper seat post for smooth operation and service them if necessary.



# Maintenance

## 1. Washing Your Trail Pistol

1. Avoid high pressure washing, especially near any bearings or seals. We designed the pivot bearings to be shielded from water spray as much as practical, but gentle washing will produce longer bearing lives. Use a mild soap and water.

## 2. Small Parts

1. 12x148 Rear axle, derailleur hanger, nut insert and hanger bolt are all standard Syntace parts, available from Guerrilla Gravity or most bike shops

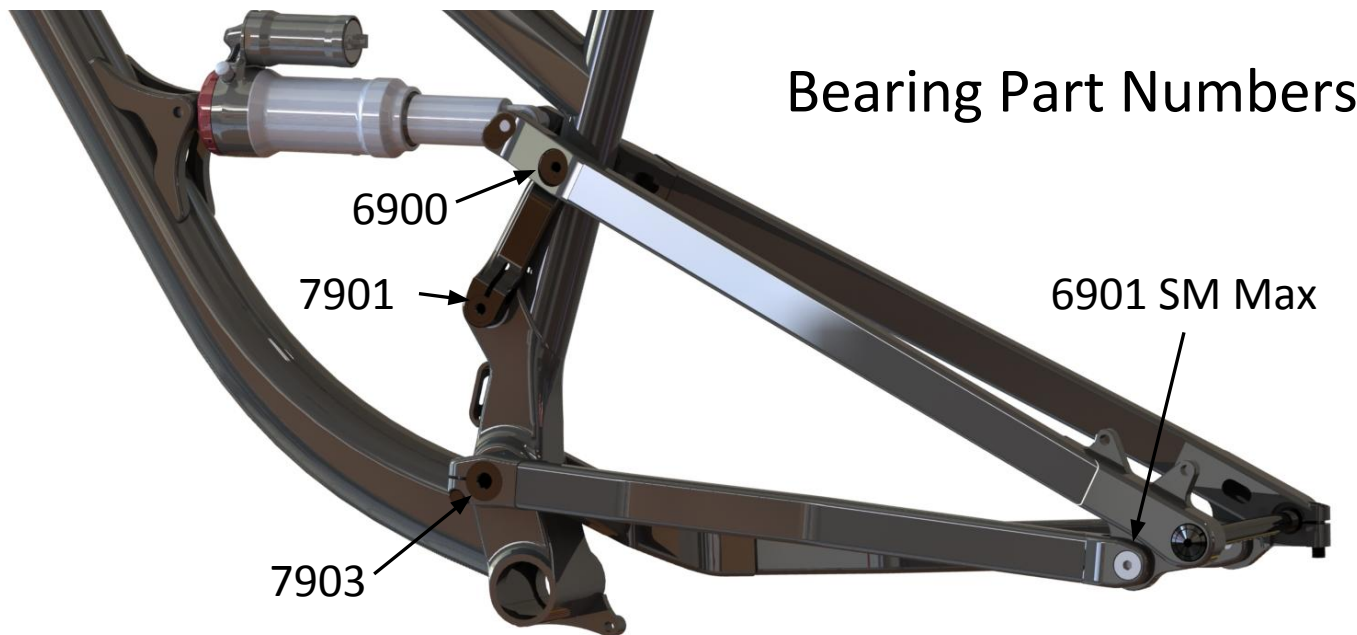

# Bearings

## 1. Replacement

1. The main pivot and rocker pivot have single row angular contact bearings (7901 upper, 7903 lower), and the orientation is critical. When replacing, the black rubber seal must face outwards as shown below. The blue seals all face inwards.
2. With all bearing replacement, apply a thin layer of grease to the outer bearing race or bearing bore in the frame before install.
3. It is also critical to get the new bearings to go in straight. Don't use a hammer. An arbor press (shown below) is best. A vice is the second best tool. If you don't have either, we recommend having a qualified mechanic/shop do the work.

Black Seals Face Outwards



Ideal Tool For The Job





# Safety

1. Mountain biking is an inherently dangerous sport, and the risk is yours to keep yourself safe while riding by wearing the proper protective equipment and riding within your abilities at all times. Guerrilla Gravity is not liable for any injuries you incur while riding and/or crashing.
2. If you ride at night, use lights and reflectors.
3. If your bike is less than fully assembled when you receive it, take it to a qualified mechanic. If you assemble it yourself, we assume no responsibility for improper construction leading to equipment failure or personal injury. If you're in doubt about who is a qualified mechanic, call us and we'll help you find one in your area.
4. Minimum leg length – If there is less than one inch between your crotch and the top tube, the bike is too big for you. Oops. Let us know if this is the case for you.
5. Serial number – Each Guerrilla Gravity bike has a serial number on the bottom of the bottom bracket. This number denotes the model, date of fabrication, and manufacturing location. Make a note of this number in your records in case your bike is stolen.

