

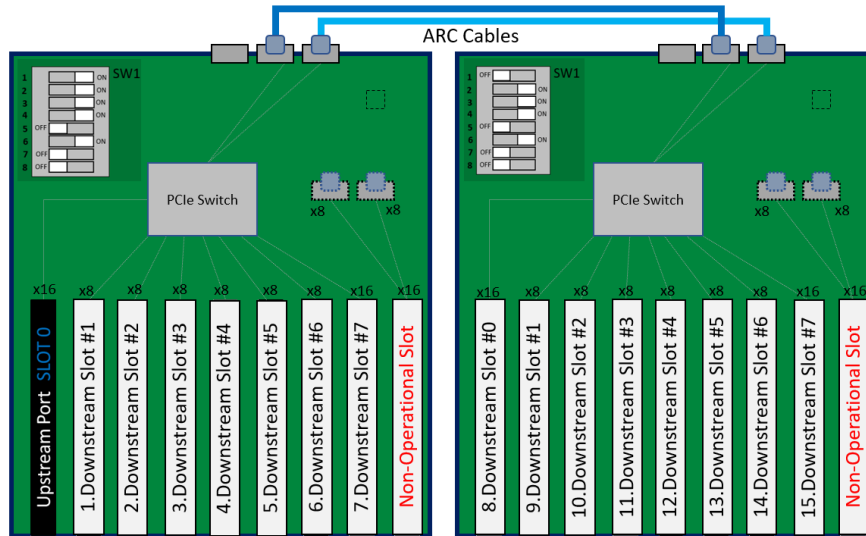

OSS-581 Gen5 Backplane



INSTALLATION GUIDE

OSS-581 Daisy-Chain Configuration



OSS
ONE STOP SYSTEMS

Table of Contents

1	Hardware Requirements	3
2	Setup / Installation	4
2.1	Set Backplane's Dipswitches	4
2.2	Connect ARC Cables	4
2.3	Connect Power Cables	7
3	Install Adapter Card.....	8
3.1	Set Target Card Dipswitches	8
3.2	Set Host Card Dipswitches.....	8
3.3	Install Target Card.....	8
3.4	Host Card Installation	9
4	Cable Installation	10
5	Complete Setup.....	11
6	Powering UP the unit	12
7	Hardware Check	12
7.1	Verify Board LEDs.....	12
7.2	Verify Adapter Card LEDs.....	13
8	How to Get More Help	14
8.1	Contacting Technical Support.....	14
8.2	Returning Merchandise.....	14
8.3	Third Party Hardware & Software Support Policy	14
8.4	Online Support Resources	14

1 Hardware Requirements

1. Two OSS-581 Backplanes
2. Two 12in ARC cables
3. OSS Gen 5 Target and Host Cards
4. Gen 5 PCIe x8 Cable (qty: 2): QSFP-DD Cables
5. Gen5 or Gen4 x16 PCIe slot (computer motherboard)

Gen5 Target and Host Card & two QSFP-DD cables

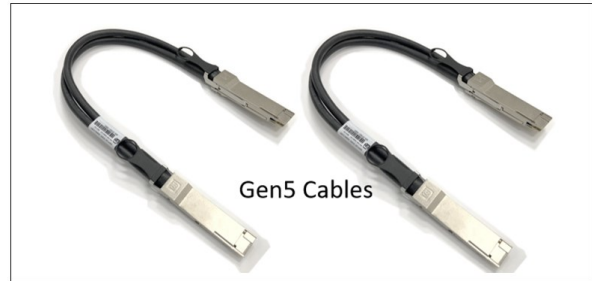
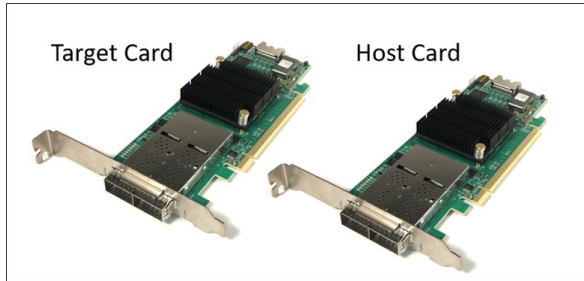

Two 12in long ARC cables and two OSS-581 backplanes

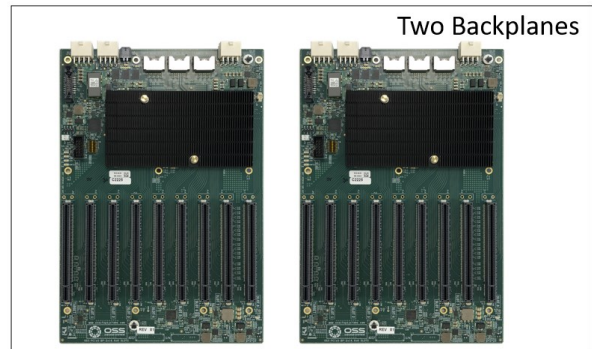
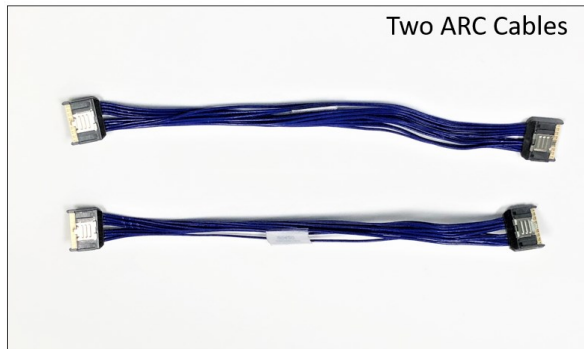

ATX Power Supply with 24pin power cable and at least two available EPS power cable. The EPS power cable is also known as CPU power cable that has 8pin power connector.

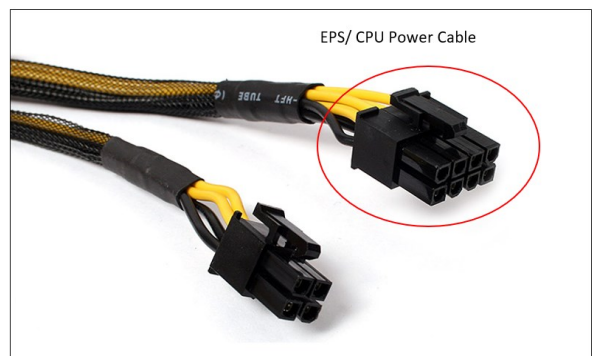
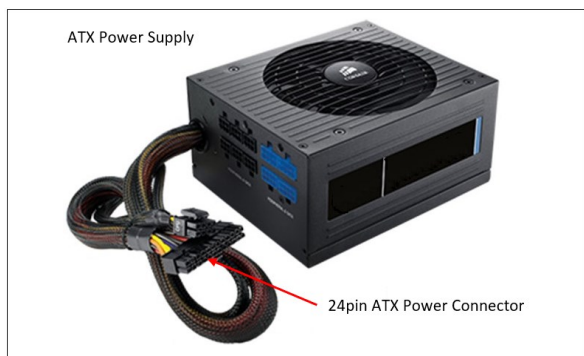

2 Setup / Installation

2.1 Set Backplane's Dipswitches

Set the Dipswitches on each backplane appropriately. Refer to the photos below for the corresponding dipswitch settings for each backplane (backplane #1 and backplane #2).

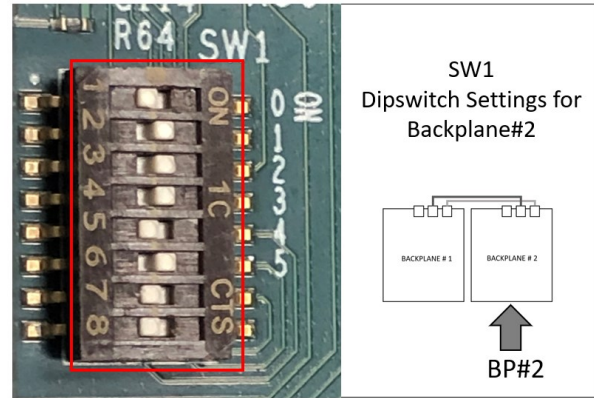
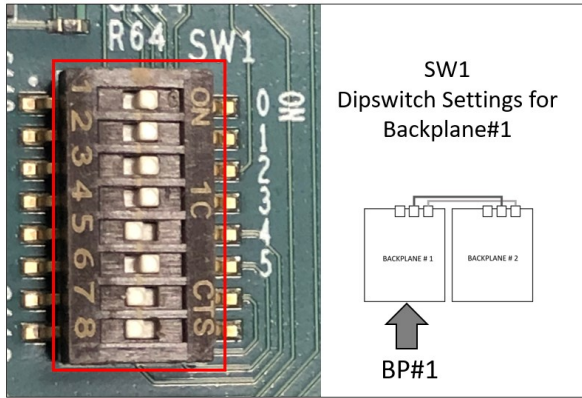

2.2 Connect ARC Cables

- Connect the 1st ARC cable to port LANES 0-7 (from backplane #1 to backplane #2). Follow the diagram below for connecting the Arc cable.

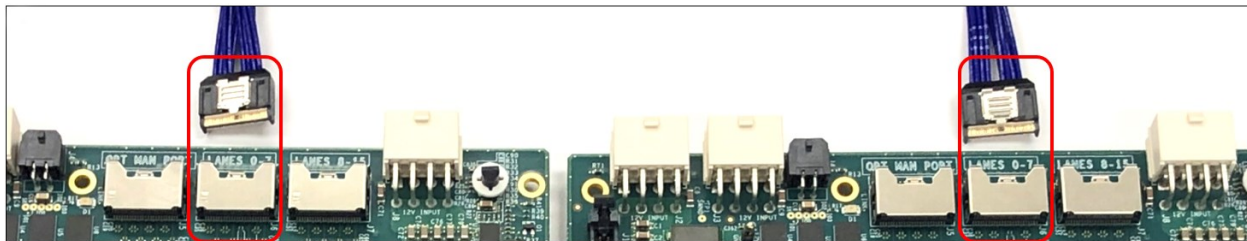
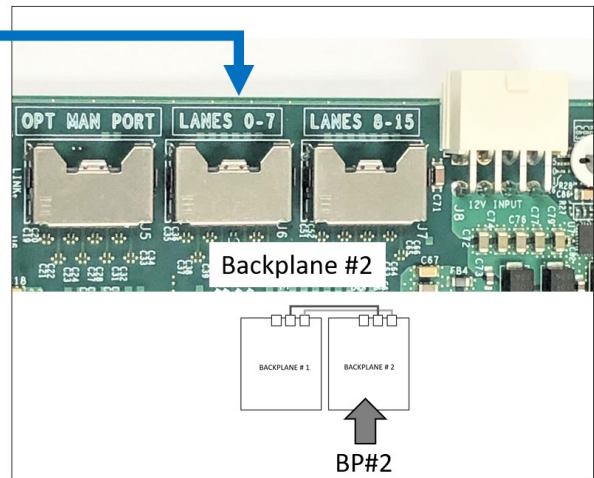
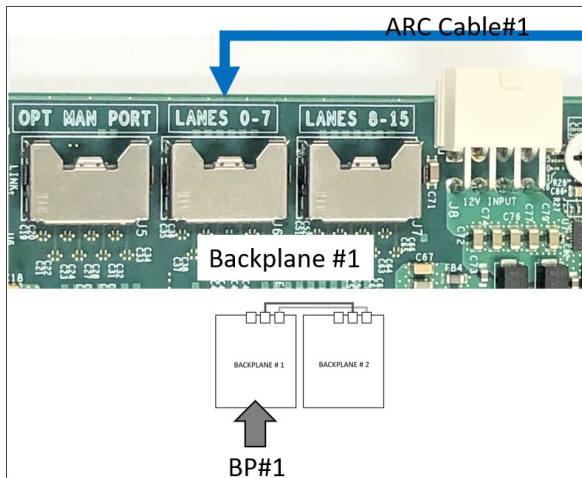

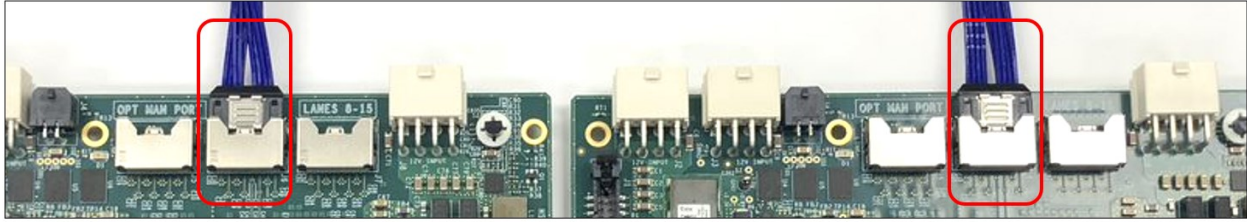

- Connect the 2nd ARC cable to port LANES 8-15 (from backplane #1 to backplane #2). Follow the diagram below for connecting the Arc cable.

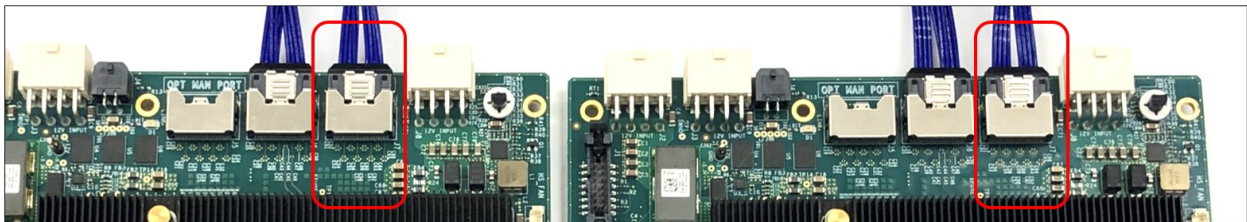
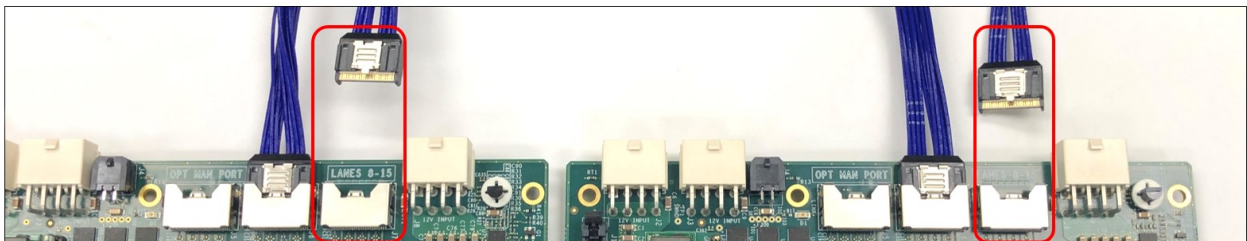
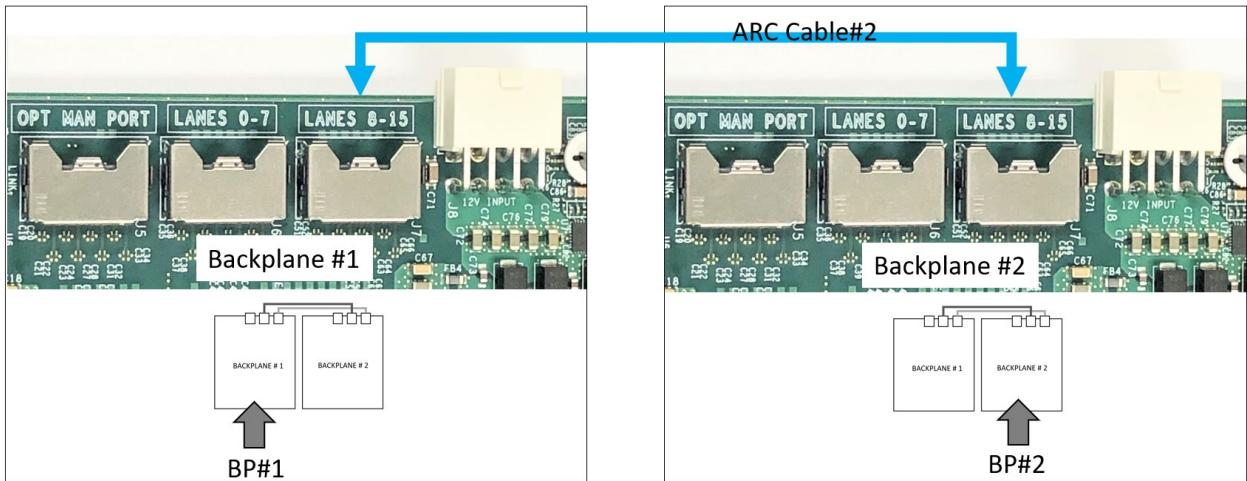

Below is the full diagram with two ARC cables connected between two OSS-581 backplanes and with the correct dipswitch settings.

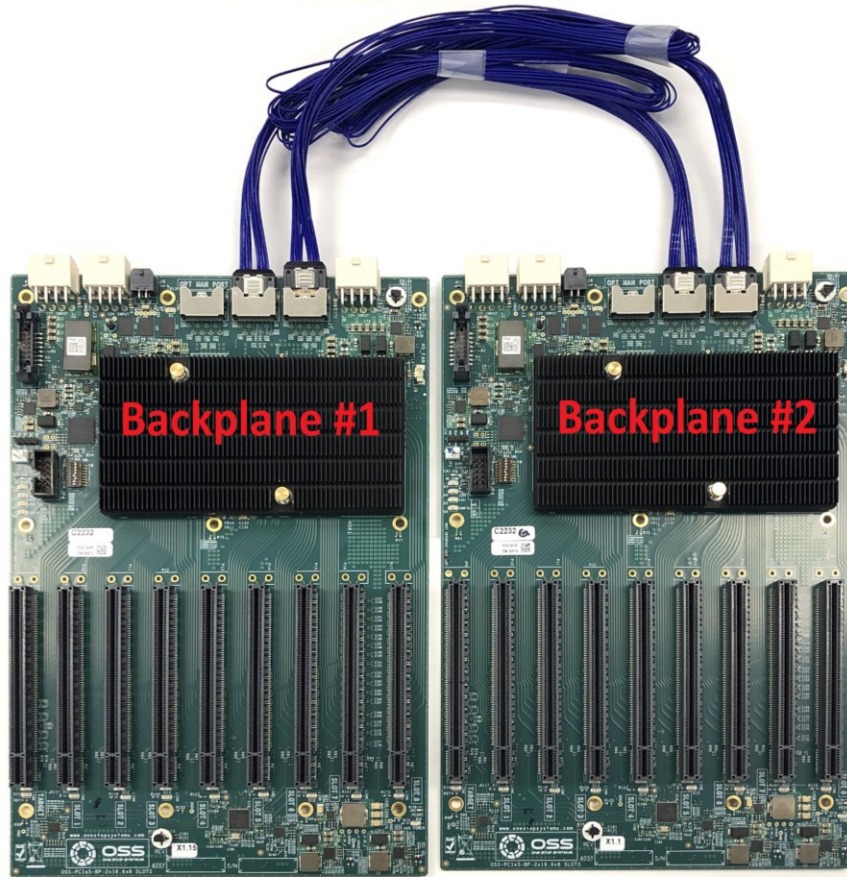
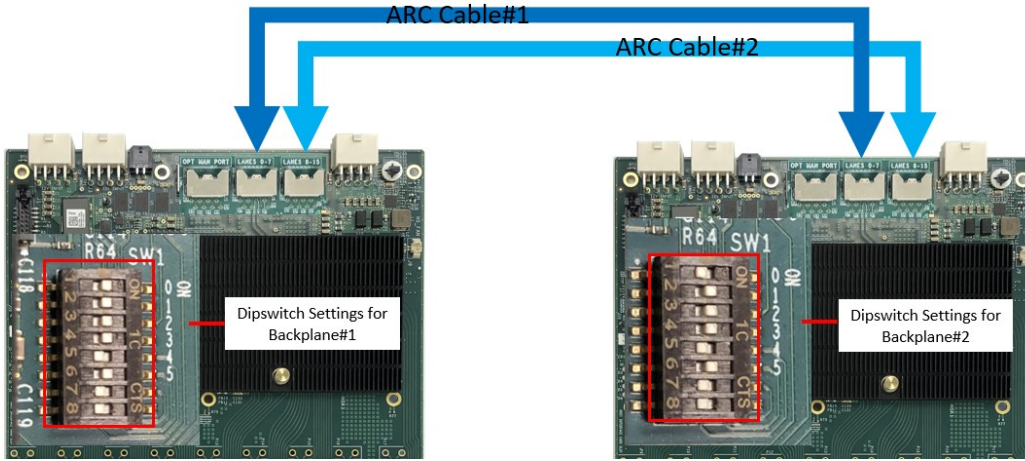

2.3 Connect Power Cables

Plug in the supplied power adapter cable (24pin-to-4pin cables). Connect the two power cables to the backplane, see photos below.

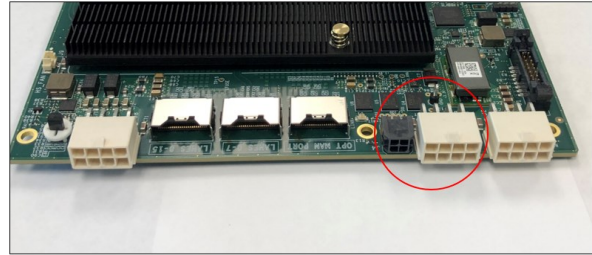
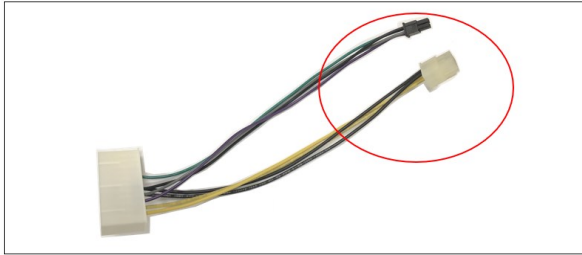

Connect the other end of the cable to the ATX power supply 24pin power connector.

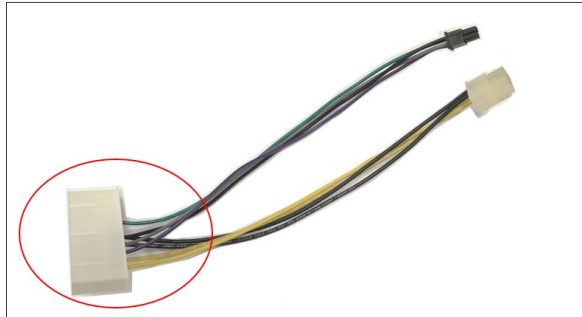

From the ATX power supply, connect the 8pin power cable to the remaining 12v input power connector on the board.

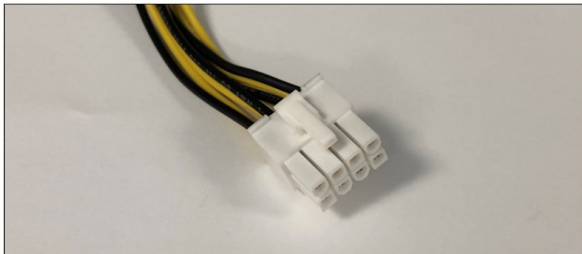

Below photo shows all the power cables attached to the backplane.

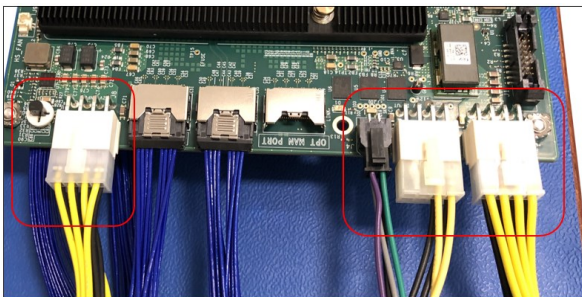

3 Install Adapter Card

3.1 Set Target Card Dipswitches

Set the dipswitches on the card to target mode, see photo below for correct settings.

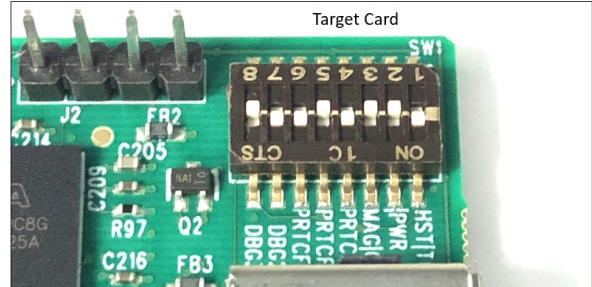
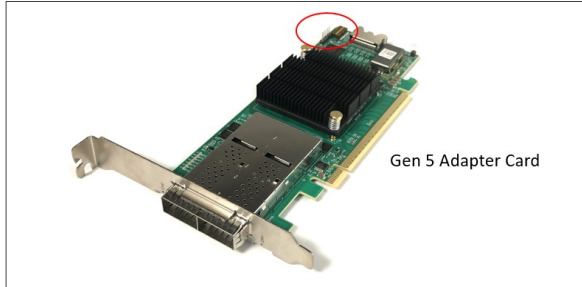

3.2 Set Host Card Dipswitches

Set the dipswitches on the card to host mode, see photo below.

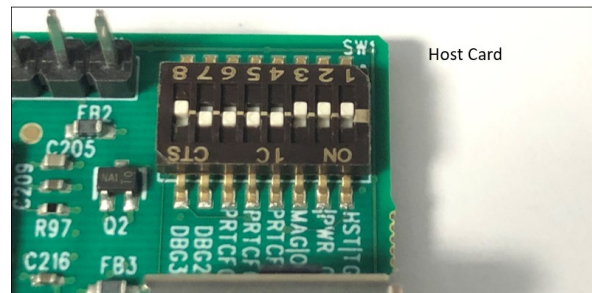
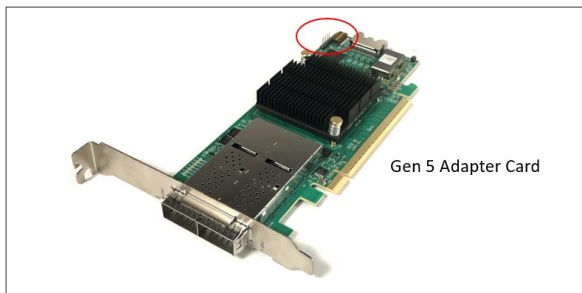

3.3 Install Target Card

Plug in the target card in the upstream slot on the backplane #1.

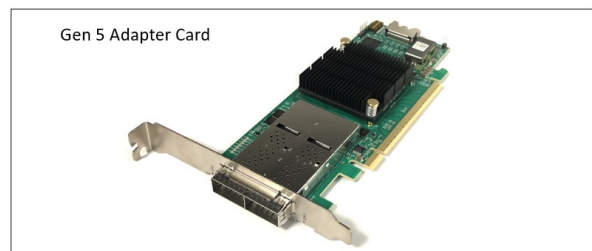
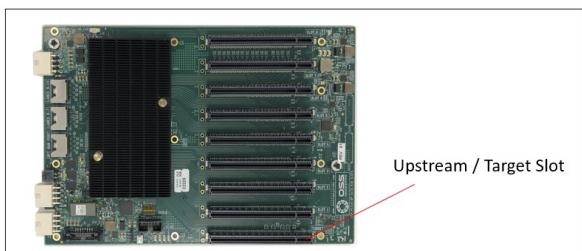

As shown below, the OSS target card is installed in Upstream slot 0 of backplane #1.

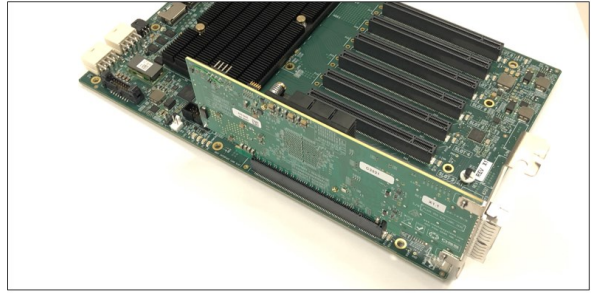

3.4 Host Card Installation

The host card can only be installed in the computer motherboard's PCIe slot. Install the Host card in an x16 Gen4 or Gen5 PCIe slot.

x16 PCIe Gen 5 slot

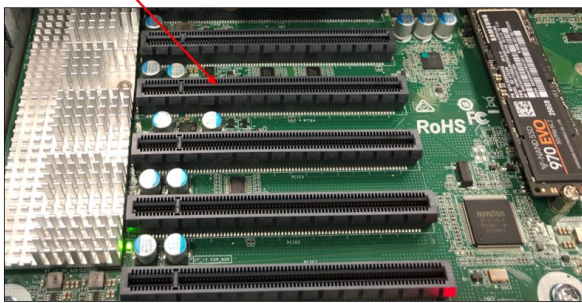

OSS Gen5 Host Card

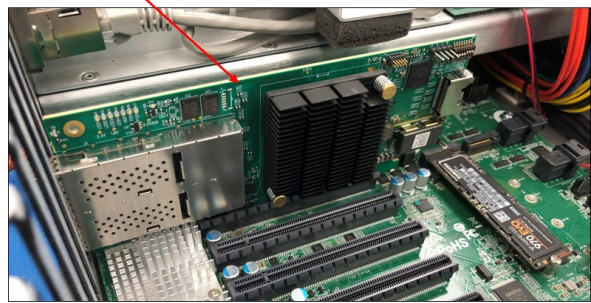

4 Cable Installation

Plug in the two cables to the target card. See photos below for the correct orientation of the cables when connecting to the card.

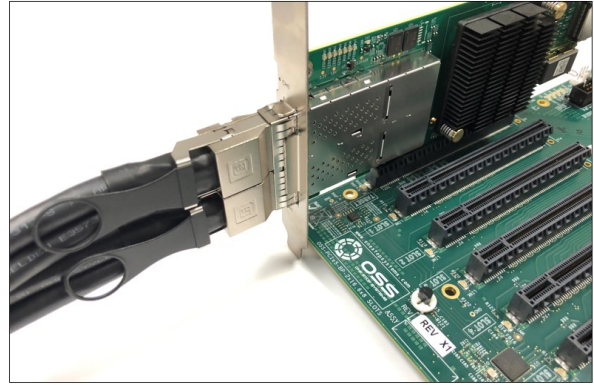
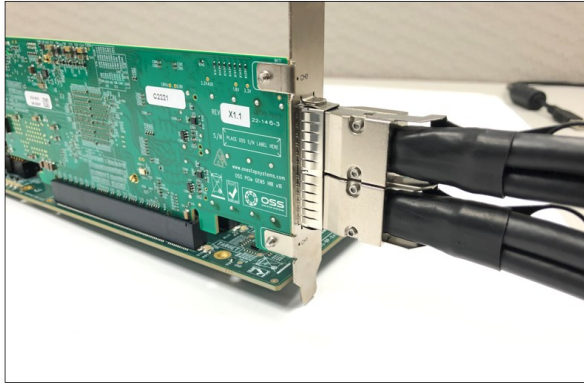

Connect the other end of the cables to the host adapter card.

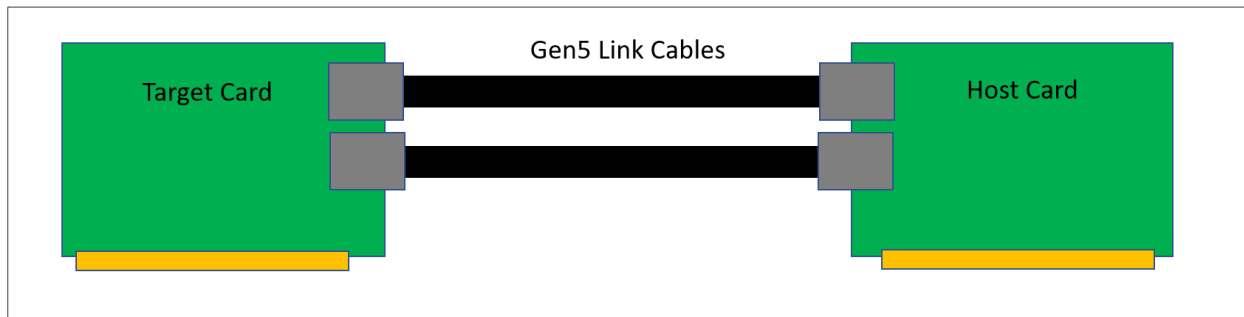

5 Complete Setup

Below diagram is the completed hardware setup. Host computer is linked to the daisy-chained OSS expansion boards.

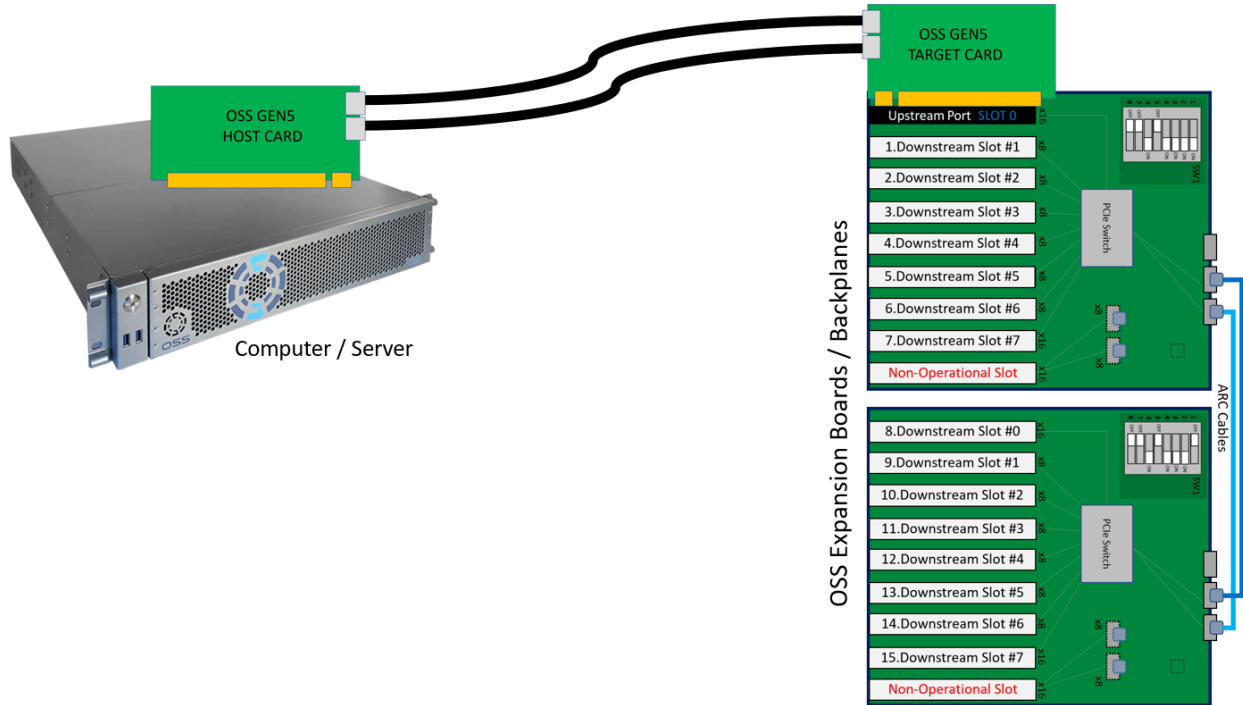

6 Powering UP the Unit

- Power ON the Gen5 backplane first.
- Turn ON the host computer.

7 Hardware Check

7.1 Verify Board LEDs

After powering UP the host computer, the Target SLOTTLED on the backplane will illuminate as solid green as shown below.

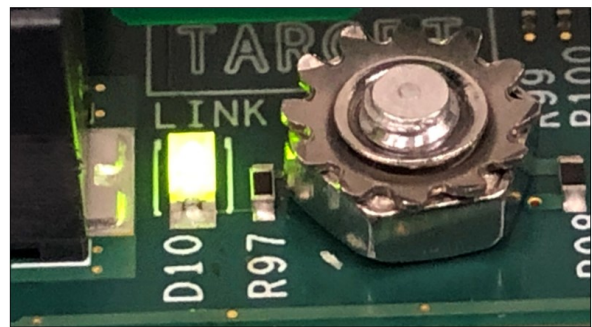
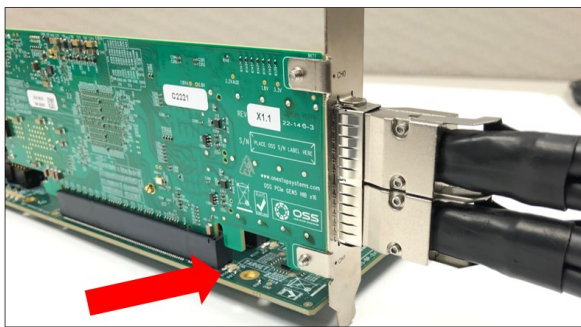

Check the board LEDs. A fully operational back plane will illuminate the following LEDs.

- D4 & D5
- D19: AUX power, solid green.

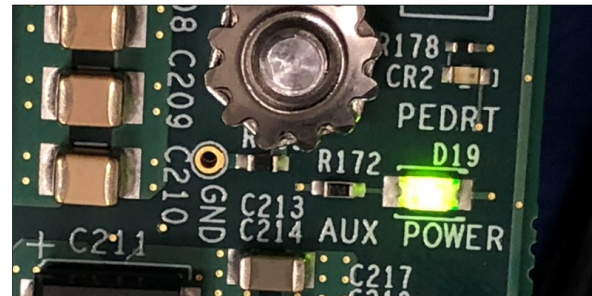
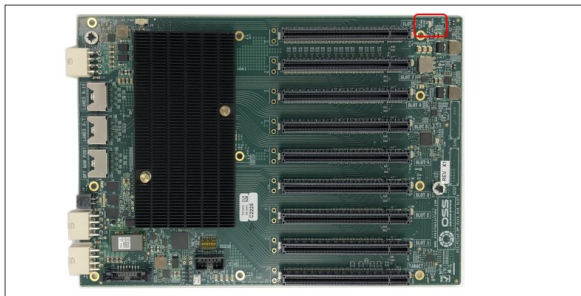
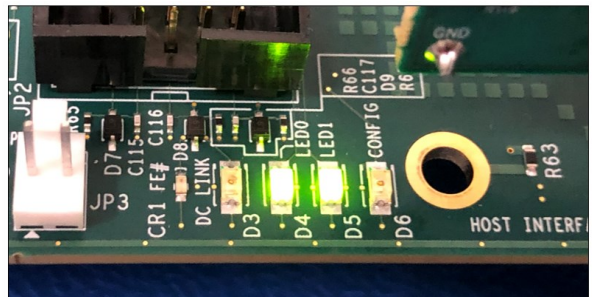
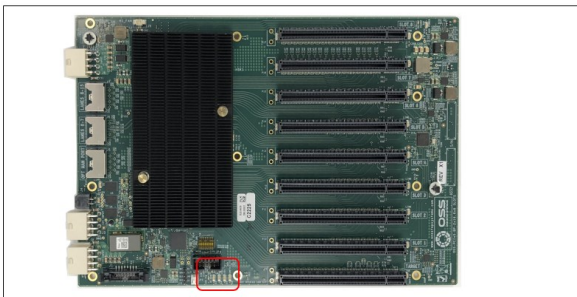

7.2 Verify Adapter Card LEDs

After powering ON the host computer, it will instantly power UP the target device.

- A fully operational adapter cards will illuminate the following LEDs on both Host and Target cards.

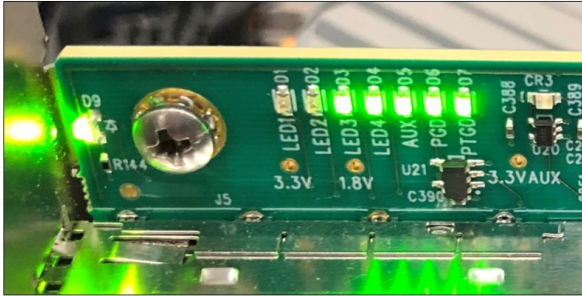

8 How to Get More Help

8.1 Contacting Technical Support

Our support department can be reached by phone at [1 \(760\) 745-9883](tel:17607459883). Support is available Monday through Friday, 8:00 AM to 5:00 PM PT. When contacting Technical Support make sure to include the following information:

1. Exact and correct serial #
2. Service Ticket or Case # (if you already submitted an online request)
3. Computer Type & Model: Operating System
4. Make & Model of PCI/PCIe cards: Application
5. Problem description

When submitting an online technical support request always provide a valid working e-mail address, phone number, shipping address and proper contact name. Check your e-mail for an automated response containing the case # and updates. You can also visit our web site at this address <https://www.onestopsystems.com> for a quick response, use the Technical Support and RMA Request Form available in the Support Section of the website. Simply complete the form with all required information. Please make sure that your problem description is sufficiently detailed to help us understand your problem.

Shipping or Transporting of Expansion Unit with PCI / PCIe cards.

Any PCIe cards in **should be removed** (or not to be installed) prior to shipment to avoid or prevent damage. Note: Expansion board and PCIe / PCI cards that arrive damaged in shipment will not be covered under warranty.

8.2 Returning Merchandise

If factory service is required, a Service Representative will give you a Return Merchandise Authorization (RMA) number. Put this number and your return address on the shipping label when you return the item(s) for service. Please note that One Stop Systems WILL NOT accept COD packages, so be sure to return the product freight and duties paid. Ship the well-packaged product to the address below:

Attention: RMA # _____, One Stop Systems
2235 Enterprise Street, #110
Escondido, CA 92029
USA

It is not required, though highly recommended, that you keep the packaging from the original shipment of your product. However, if you return a product for warranty repair/ replacement or take advantage of the 30-day money back guarantee, you will need to package the product in a manner similar to the manner in which it was received from our plant. We cannot be responsible for any physical damage to the product or component pieces of the product (such as the host or expansion interfaces for the expansion chassis) that are damaged due to inadequate packing. Physical damage sustained in such a situation will be repaired at the owner's expense in accordance with Out of Warranty Procedures. Please, protect your investment, a bit more padding in a good box will go a long way to ensuring the device is returned to use in the same condition you shipped it in. Please call for an RMA number first.

8.3 Third Party Hardware & Software Support Policy

OSS evaluates, certifies, and bundles many popular third-party hardware and software products with OSS hardware for ease of use and guaranteed operation. OSS encourages customer innovation by combining OSS products in new and interesting ways with third party and customer developed hardware and software. Unfortunately, with infinite combinations of hardware and software, OSS cannot assess and validate every configuration. OSS is committed to supporting its products and identifying if any technical issue may be related to third-party hardware or software. To isolate technical issues, OSS may request that the system be returned to the same configuration that shipped from the OSS factory and any non-OSS supplied third-party hardware or software be removed from the system during troubleshooting.

We assess, certify, and support many third-party hardware and software products along with OSS hardware and are happy to integrate a fully supported system. Ask us about that service and we would be happy to help. If an OSS product is fully functional and a support issue is related to third-party hardware or software that did not ship from the OSS factory, the customer requesting support should reach out to the third-party vendor for assistance to fully troubleshoot the issue.

8.4 Online Support Resources

As a product user and customer, listed below are our Online Support Resources

<https://www.onestopsystems.com/support> provides Knowledgebase Articles such as troubleshooting methods, compatibility, FAQ, documentation, and product technical information. If you need technical support, product assistance or have a technical inquiry we encourage you to submit it on-line using our Technical Support Form. If you need to send a unit for repair or diagnostic evaluation, fill out our RMA (Return Material Authorization) online request form.



2235 Enterprise Street, Suite#110, Escondido CA 92029

Toll-Free : +1(800)285-8900 US • Main: +1 (760) 745-9883 • Fax: +1 (760) 745-9824

www.onestopsystems.com