

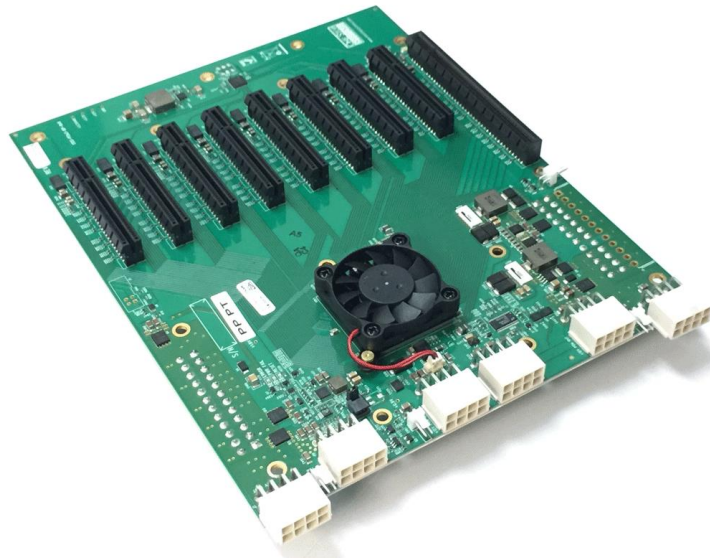

# Expansion Backplane, 8 PCIe x8 slots, Gen3

OSS-BP-452



## User Manual

SKU: OSS-BP-452-ATX



**OSS**  
ONE STOP SYSTEMS

[www.onestopsystems.com](http://www.onestopsystems.com)

# Table of Contents

<b>Preface .....</b>	<b>4</b>
Advisories.....	4
Safety Instructions.....	5
Protecting Against Electrostatic Discharge .....	6
<b>1 Product Information .....</b>	<b>7</b>
1.1 Features .....	7
1.2 General Specification .....	7
1.3 Block Diagram .....	7
1.3.1 Backplane.....	7
1.3.2 Host and 8-slot backplane.....	8
1.4 Supported Configuration .....	8
1.5 PCIe Slots and Ports Assignment.....	9
1.6 Dimension.....	9
1.7 Parts OSS-452 Board.....	10
1.8 Card Slot Link LEDs.....	11
1.9 Slot Type.....	11
1.10 Force Power ON .....	12
1.11 Connector Pin-Outs.....	13
<b>2 Hardware Requirements .....</b>	<b>14</b>
2.1 Computer Motherboard Requirement .....	14
2.2 Host and Target Cards.....	14
2.2.1 x8 Gen3 OSS Host and Target cards.....	15
2.2.2 x16 Gen3 OSS Host and Target cards.....	15
2.3 x8 or x16 lpass Cable.....	15
2.4 Power Supply.....	16
<b>3 Software Requirement .....</b>	<b>16</b>
<b>4 Hardware Installation .....</b>	<b>17</b>
4.1 Installation-Procedures Overview.....	17
4.2 Connect ATX 24-pin Power Cable.....	18
4.3 Mount OSS-452 board.....	18
4.4 Plug-in 12V PSU Cable Connector .....	19

4.5 Install Target & Host Card..... 20

4.6 Install Host Card ..... 20

4.7 Connect Link Cable..... 21

4.8 Connect Power Cord / Cable ..... 22

4.9 Connect to Electrical Outlet..... 23

4.10 Power ON the Power Supply..... 23

4.11 Power ON the Host Computer..... 23

4.12 Power ON the Expansion Unit ..... 23

**5 Hardware Check ..... 24**

5.1 LinkUP LED (CBL & EDG)..... 24

5.2 Target Slot & PWRGO LEDs ..... 24

**6 Check OSS Device on Windows ..... 25**

6.1 How to verify OSS Device on Windows OS..... 25

6.2 How to verify OSS Device on Linux OS..... 26

**7 PCIe Cards Installation..... 28**

7.1 Install PCIe card(s) ..... 28

7.2 PCIe Cards Combination ..... 28

**8 Verify or Check PCIe Devices ..... 30**

8.1 Verify PCIe Hardware ..... 30

8.1.1 Slot LED Status indicators..... 30

8.2 Check PCIe cards on Windows OS..... 31

8.3 Check PCIe cards on Linux OS..... 32

**9 Contacting Technical Support ..... 33**

**10 Returning Merchandise to One Stop Systems..... 33**

**11 Shipping / transporting the unit ..... 34**

**12 APPENDIX A Compliance..... 34**

FCC..... 34

CE ..... 34

# Preface

## Advisories

Five types of advisories are used throughout this manual to provide helpful information, or to alert you to the potential for hardware damage or personal injury.

**NOTE**

Used to amplify or explain a comment related to procedural steps or text.

**IMPORTANT**

Used to indicate an important piece of information or special “tip” to help you

**CAUTION**

Used to indicate and prevent the following procedure or step from causing damage to the equipment.

**WARNING**

Used to indicate and prevent the following step from causing injury.

**DANGER or STOP**

Used to indicate and prevent the following step from causing serious injury or significant data loss

Disclaimer: We have attempted to identify most situations that may pose a danger, warning, or caution condition in this manual. However, One Stop Systems does not claim to have covered all situations that might require the use of a Caution, Warning, or Danger indicator.

## Safety Instructions

Always use caution when servicing any electrical component. Before handling the One Stop Systems Expansion chassis, read the following instructions and safety guidelines to prevent damage to the product and to ensure your own personal safety. Refer to the "Advisories" section for advisory conventions used in this manual, including the distinction between Danger, Warning, Caution, Important, and Note. Always use caution when handling/operating the computer. Only qualified, experienced, authorized electronics personnel should access the interior of the computer and expansion chassis.



### **WARNING**

Never modify or remove the radio frequency interference shielding from your workstation or expansion unit. To do so may cause your installation to produce emissions that could interfere with other electronic equipment in the area of your system.

When Working Inside a Computer

Before taking covers off a computer, perform the following steps:

Turn off the computer and any peripheral devices.

Disconnect the computer and peripheral power cords from their AC outlets or inlets in order to prevent electric shock or system board damage.

In addition, take note of these safety guidelines when appropriate:

To help avoid possible damage to systems boards, wait five seconds after turning off the computer before removing a component, removing a system board, or disconnecting a peripheral device from the computer.

When you disconnect a cable, pull on its connector or on its strain-relief loop, not on the cable itself. Some cables have a connector with locking tabs. If you are disconnecting this type of cable, press in on the locking tabs before disconnecting the cable. As you pull connectors apart, keep them evenly aligned to avoid bending any connector pins. Also, before connecting a cable, make sure both connectors are correctly oriented and aligned.



### **CAUTION**

Do not attempt to service the system yourself except as explained in this manual. Follow installation instructions closely.

## Protecting Against Electrostatic Discharge



### **Electrostatic Discharge (ESD) Warning**

Electrostatic Discharge (ESD) is the enemy of semiconductor devices. You should always take precautions to eliminate any electrostatic charge from your body and clothing before touching any semiconductor device or card by using an electrostatic wrist strap and/or rubber mat.

Static electricity can harm system boards. Perform service at an ESD workstation and follow proper ESD procedures to reduce the risk of damage to components. One Stop Systems strongly encourages you to follow proper ESD procedures, which can include wrist straps and smocks, when servicing equipment.

You can also take the following steps to prevent damage from electrostatic discharge (ESD):

When unpacking a static-sensitive component from its shipping carton, do not remove the component's anti-static packaging material until you are ready to install the component in a computer. Just before unwrapping the anti-static packaging, be sure you are at an ESD workstation or are grounded.

When transporting a sensitive component, first place it in an anti-static container or packaging.

Handle all sensitive components at an ESD workstation. If possible, use anti-static floor pads and workbench pads.

Handle components and boards with care. Do not touch the components or contacts on a board. Hold a board by its edges or by its metal mounting bracket.

# 1 Product Information

Backplane with eight PCIe x8 Gen3 slots. Requires an OSS target adapter card (in the target slot) and OSS host adapter card (in the host computer).

- OSS target backplanes only support OSS target adapter cards.
- OSS PCIe backplanes support expansion cards (PCIe card) designed to the PCIe PCI-SIG specification.
- Target system or PCIe expansion chassis / board must have or use an ATX-style power supply.

## 1.1 Features

- One OSS PCIe x16 3.0 target slot (Upstream slot) for OSS Target cable adapter card.
- Eight PCIe x8 3.0 expansion slots (Downstream slot).
- x8 Open-ended mechanical slot
- ATX power input

## 1.2 General Specification

- Dimension (H x L): 7.175" x 8.820"
- Power: Dual ATX
- Slots:
  - 1 OSS target slot, x16 mechanical and electrical (Gen3)
  - 8 PCIe x8 3.0 electrical; x8 open-ended mechanical

## 1.3 Block Diagram

### 1.3.1 Backplane

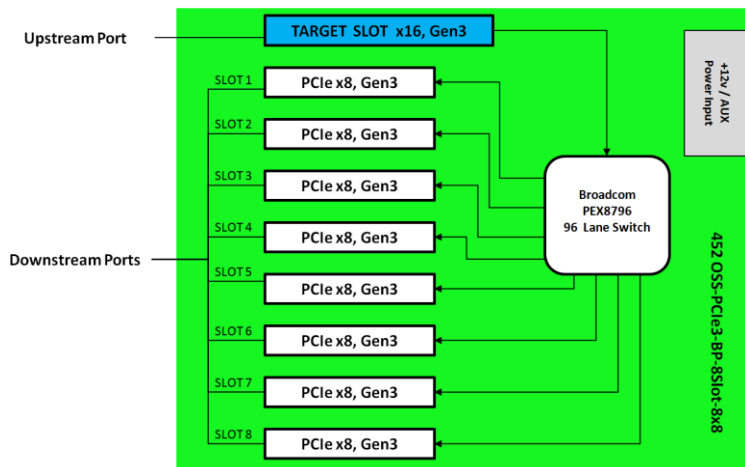

### 1.3.2 Host and 8-slot backplane

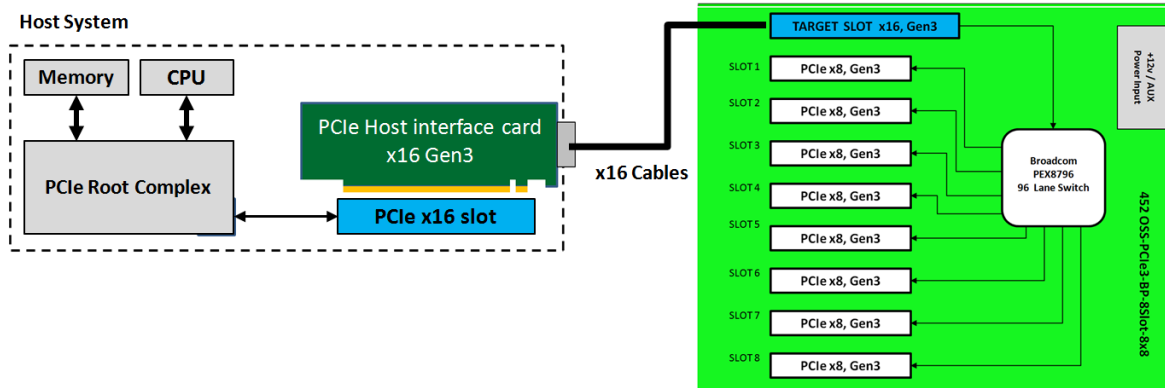

### 1.4 Supported Configuration

- Attached to one host server / computer.
- Two Cable adapter cards: One in the expansion backplane and the other in the host computer.

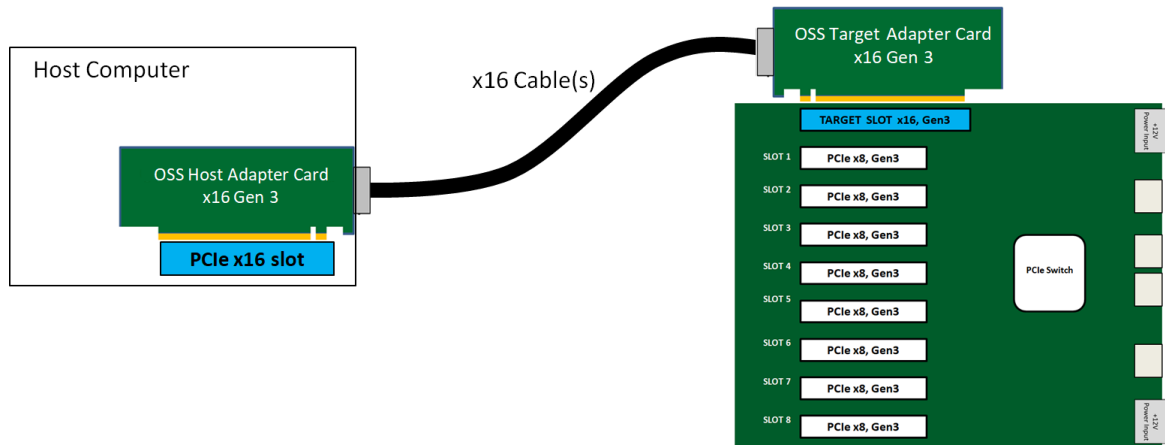



## 1.5 PCIe Slots and Ports Assignment

Each PCIe slot has its own port assignment, see picture below. There are 9 PCIe slots on the backplane (452 model), the Target slot (Upstream slot) which is assigned for the “Target Card” and 8 available slots for downstream devices (PCIe cards).

- All slots have their own corresponding port.
- The port assignments are hard-coded and cannot be modified.
- For example, a single GPU or PCIe card that is plugged into slot P2 on the backplane, port 1 will be automatically assigned to the card.

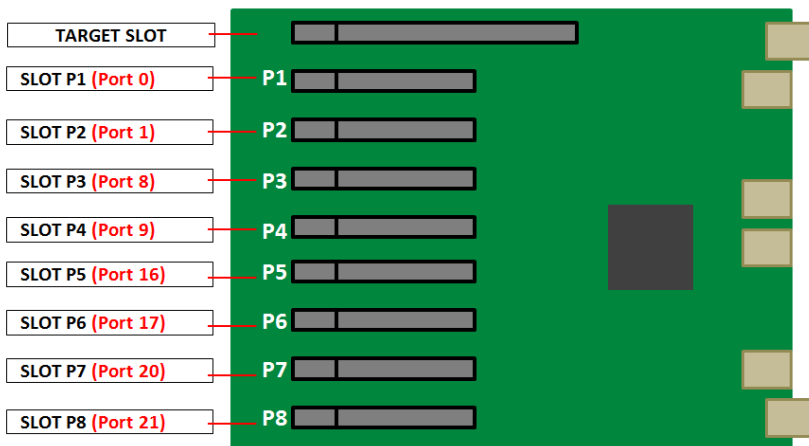

## 1.6 Dimension

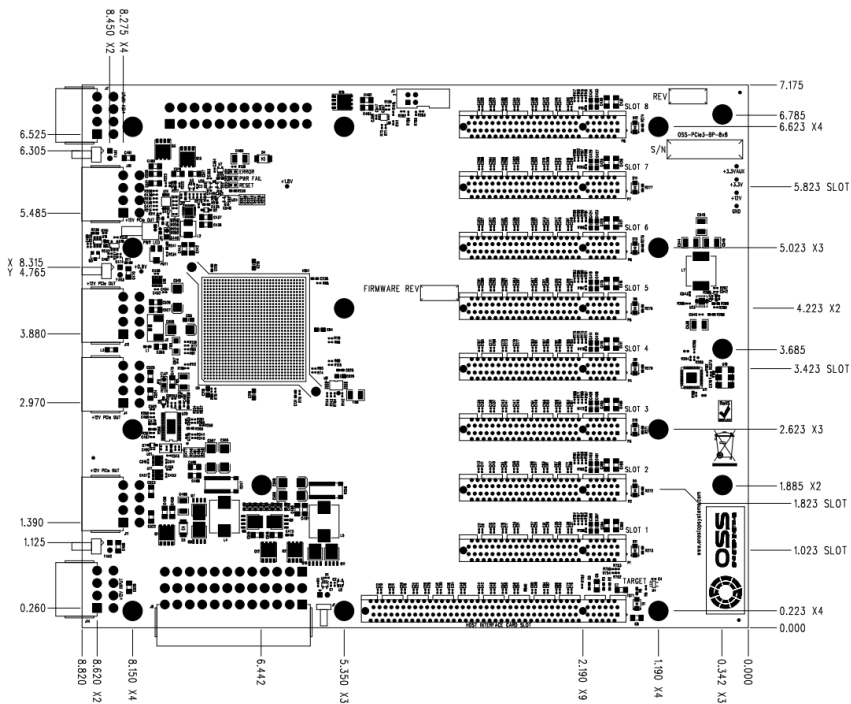

## 1.7 Parts OSS-452 Board

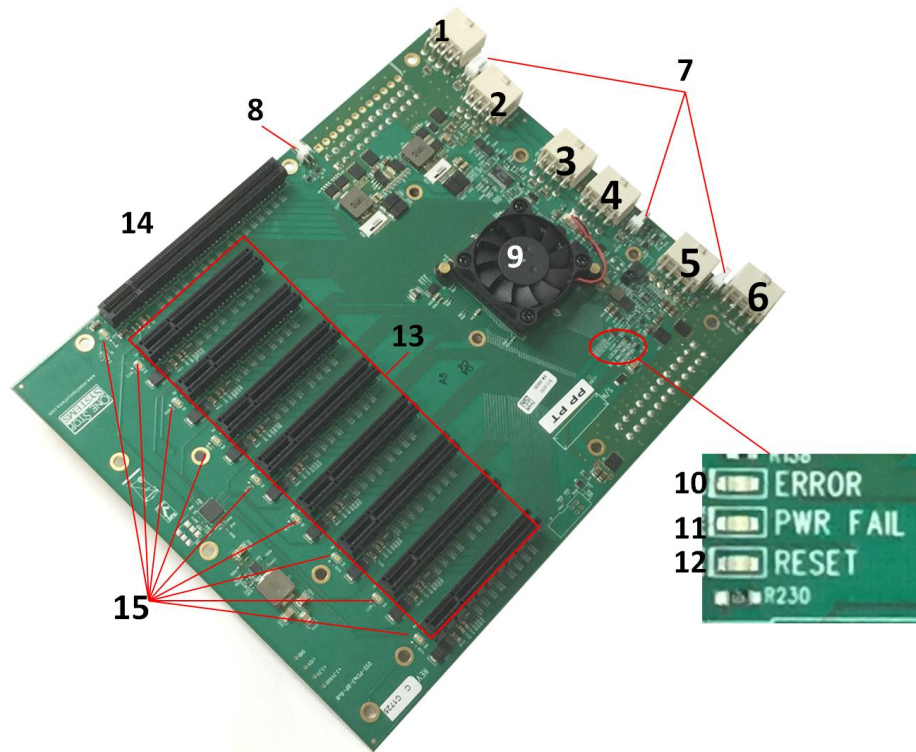

Item#	Name	Description
1	J14	12V <b>input</b> power for the 452 board when used in all configurations.
2	J11	12V output power for GPU (not used in Value Chassis)
3	J4	12V output power for GPU (not used in Value Chassis)
4	J12	12V output power for GPU (not used in Value Chassis)
5	J10	12V output power for GPU (not used in Value Chassis)
6	J7	12V <b>input</b> power for the 452 board when used in a Cube configuration
7	FAN1,FAN2, FAN3	fan connectors
8	J1	FORCE PWRON (engineering/debug use only)
9	PCIe Switch & Fan	PCIe Switch PEX8796, 96 Lane Switch & Fan
10	Error LED	State of the PEX8796 Fatal Error signal, Red means error has occurred
11	PWRFAIL	Output of the voltage monitor. Red means that one or more voltage rails are out of specification. Will automatically set PERST low
12	RESET	State of the PE_RST# signal. Red means that PERST is low
13	P1 to P8	PCIe slots (x8 lane) for cards. x8 Mechanical, x8 Electrical
14	P0	Target Slot ; Upstream Port. x16 Mechanical, x16 Electrical
15	Slot LEDs	PCIe Gen Speed LED Indicator (Gen1, Gen2, Gen3)

## 1.8 Card Slot Link LEDs

Each slot has its own corresponding LED indicators. It will signify the GEN speed of the card that is plugged in, see info below.

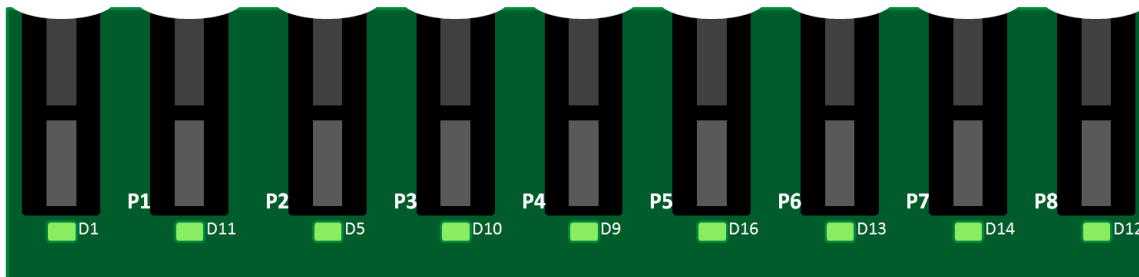

SLOT#	PORT	LED	Description	When Lit (Solid Green or blinking)	When Off
Slot P1	PORT 0	D11	Slot P1 Link	Solid - Gen 3 Link; Fast Blinking - Gen 2 Link, Slow Blinking - Gen 1 Link	OFF - Not Linked / No Card present in the slot
Slot P2	PORT 1	D5	Slot P2 Link	Solid - Gen 3 Link; Fast Blinking - Gen 2 Link, Slow Blinking - Gen 1 Link	OFF - Not Linked / No Card present in the slot
Slot P3	PORT 8	D10	Slot P3 Link	Solid - Gen 3 Link; Fast Blinking - Gen 2 Link, Slow Blinking - Gen 1 Link	OFF - Not Linked / No Card present in the slot
Slot P4	PORT 4	D9	Slot P4 Link	Solid - Gen 3 Link Fast Blinking - Gen 2 Link, Slow Blinking - Gen 1 Link	OFF - not Linked/ No Card present in the slot
Slot P5	PORT 16	D6	Slot P5 Link	Solid - Gen 3 Link Fast Blinking - Gen 2 Link, Slow Blinking - Gen 1 Link	OFF - Not Linked / No Card present in the slot
Slot P6	PORT 17	D13	Slot P6 Link	Solid - Gen 3 Link Fast Blinking - Gen 2 Link, Slow Blinking - Gen 1 Link	OFF - Not Linked / No Card present in the slot
Slot P7	PORT 20	D14	Slot P7 Link	Solid - Gen 3 Link Fast Blinking - Gen 2 Link, Slow Blinking - Gen 1 Link	OFF - Not Linked / No Card present in the slot
Slot P8	PORT 21	D12	Slot P8 Link	Solid - Gen 3 Link Fast Blinking - Gen 2 Link, Slow Blinking - Gen 1 Link	OFF - Not Linked / No Card present in the slot

## 1.9 Slot Type

Slot Type: open ended PCIe connector, x8 mechanical and x8 electrical. The slot can accommodate x2,x4,x8 and x16 cards.

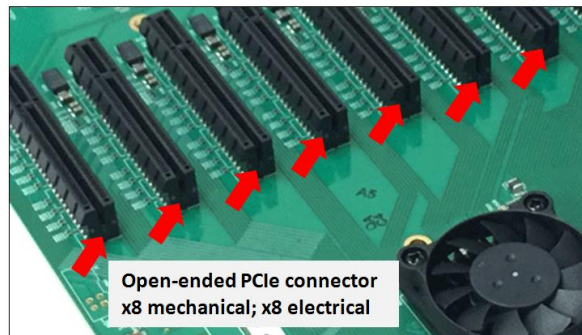
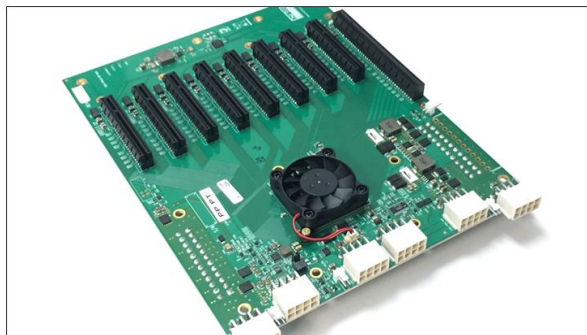

## 1.10 Force Power ON

The 452 board has a connector for a shunt / jumper that will enable force power on to the target device. This is the J1 connector located next to the upstream slot where the Target card is plugged in.

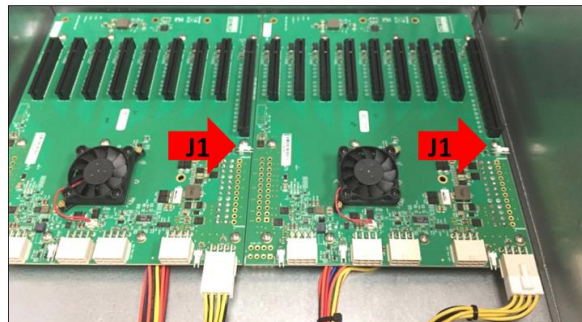
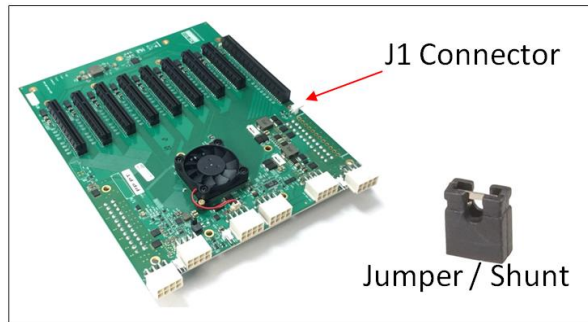

When using a different Gen3 cards such as HIB68-x16 (SFF-8644 cable connectors) plus Fiber Optic cables or / and NON-CMI cables (Mini SAS Cables) the backplane needs to be jumpered.

1. Place jumper on J1 connector.
2. Remove the target card first from the slot in order to access the J1 connector.
3. Place the jumper or shunt on pin 1 & 2 of the J1 connector, see photos below

With jumper / shunt on the backplane allows to force power ON the target.

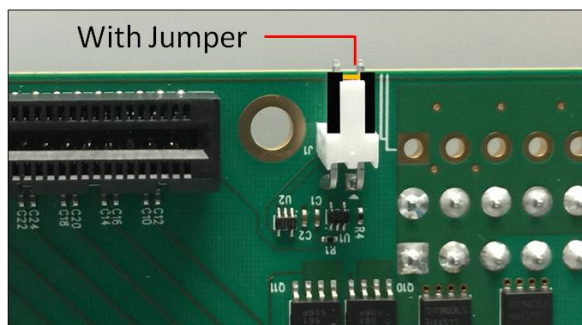
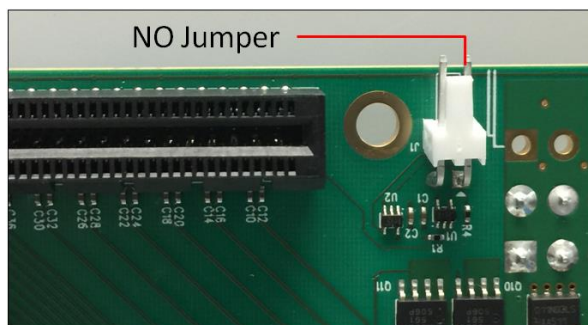

Using a NON-CMI cables and / or Fiber Optic cables the expansion needs to be tuned on (full power) prior to the host turning on. This can be achieved by placing a jumper on the J1 connector (PS-ON) of the backplane and sliding the FORCE-PWRON switch on the TARGET card to ON position. This will then allow the FPGA to generate a PERST for the target switch and the backplane switch as soon as the AC power is plugged in.

## 1.11 Connector Pin-Outs

Connector	Definition
J1	Force Power On
J3	I2C Interface
J4, J10, J11, J12	12V Output Power
J6, J7, J8, J14	Input Power
JP1, JP5	Power Standby LED
JP3	Fan Speed Control

J3 – I2C Interface Connector (3M P/N; 929710-10-02-RK)

Pin	Definition	Pin	Definition
1	SMCLK	2	GND
3	SMDAT	4	NC

J6, J8 – Input Power (Molex P/N: 87427-2402)

Pin	Definition	Pin	Definition
1	+3.3V	13	+3.3V
2	+3.3V	14	-12V
3	GND	15	GND
4	+5V	16	PS_ON#
5	GND	17	GND
6	+5V	18	GND
7	GND	19	GND
8	PWRON	20	NC
9	+5VSB	21	+5V
10	+12V1	22	+5V
11	+12V1	23	+5V
12	+3.3V	24	GND

J1 – Force Power On (Molex P/N: 22-05-3021)

Pin	Definition
1	PWR_ON#
2	GND

J4, J10, J11, J12 – 12V Output Power (Molex P/N: 87427-0802)

Pin	Definition	Pin	Definition
1	GND	5	+12V
2	GND	6	+12V
3	GND	7	+12V
4	GND	8	+12V

J7, J14 – Input Power (Molex P/N: 87427-0802)

Pin	Definition	Pin	Definition
1	GND	5	+12V
2	GND	6	+12V
3	GND	7	+12V
4	GND	8	+12V

JP1, JP5 – Power Standby LED (Samtec P/N; TFM-102-01-L-S-RA)

Pin	Definition
1	+3.3VAUX
2	GND

FAN1, FAN2, FAN3 – Fan Speed Control (Molex P/N: 22-05-3021)

Pin	Definition
1	FAN_12V_PU
2	FAN_RTN

## 2 Hardware Requirements

This section provides the hardware parts needed for the OSS-452 board to work. It is strictly recommended to follow and use the hardware requirements listed below in order for the board to operate properly.

1. Computer / Server motherboard with x16 Gen3 PCIe slot.
2. OSS Host and Target adapter cards. The HBA (Host Bus Adapter) card or HIB (Host Interface Board) works in pair. You can use the following OSS adapter cards.
  - o OSS Gen3 x 16 Host and Target cards: OSS-PCIe-HIB38-X16
  - o OSS Gen3 x8 Host and Target Cards: OSS-PCIe-HIB25-x8
3. One Ipass cable
  - o x16 Ipass Cable for x16 adapter card
  - o Or x8 Ipass cable for x8 adapter card
4. Power Supply: Standard ATX powersupply that has 8-pin 12V cable connector.

### 2.1 Computer Motherboard Requirement

Use a computer motherboard with a Gen3 x16 PCIe slots or Gen3x8 PCIe slots.

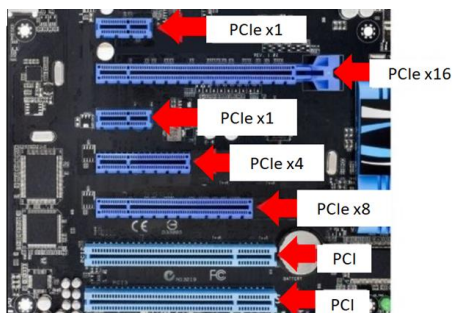

### 2.2 Host and Target Cards

You can use either x8 or x16 OSS Host and Target cards.

- The Host card must be installed in an available x16 PCI Express card slot on the host computer’s backplane or motherboard.
- The Target card must be installed in the Upstream slot of an OSS backplane. The Target card will only work on the Upstream slot.

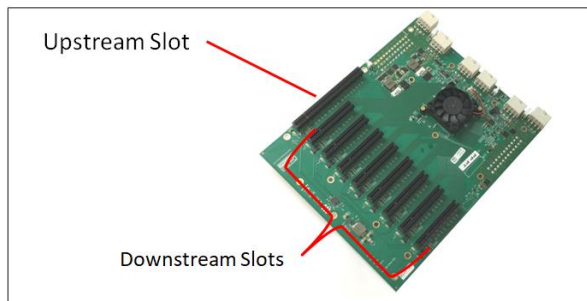



### 2.2.1 x8 Gen3 OSS Host and Target cards

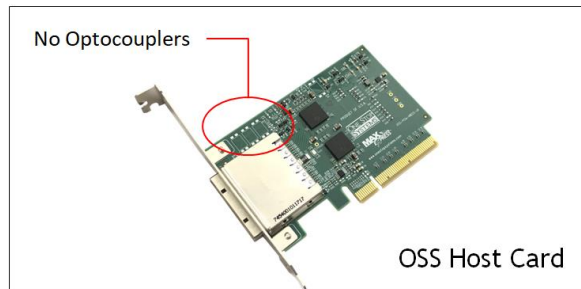
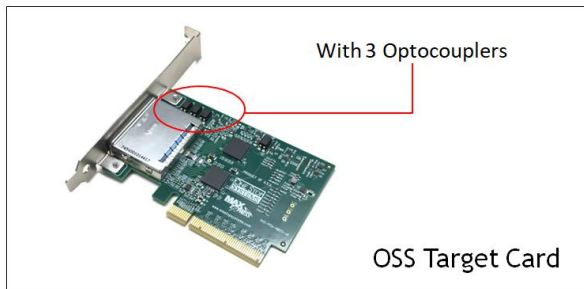

- The x8 **Host card** does not have an Optocouplers. The x8 Host card will only operate in host mode and it is primarily plugged into the computer's motherboard PCIe slot.
- The **Target card** is populated with three Optocouplers (see photo above). The card will only operate in the OSS expansion backplane Upstream slot.

### 2.2.2 x16 Gen3 OSS Host and Target cards

The OSS x16 HBA / HIB cards must be used in pair. When using the x16 card, you must set the switches to proper operating mode. There are two modes, host and target. Photos below represent each card mode switch settings.



## 2.3 x8 or x16 Ipass Cable

Use either x8 or x16 Ipass cables to link the host card and target card together. Preferably use a 1 or 1.5 meter long cable.

- When using a x8 host and target cards, you need to use x8 Ipass cable.
- x16 host and target card, use x16 Ipass cable



## 2.4 Power Supply

**Standard ATX Power Supply:** You can use a standard ATX Power Supply that has a 8-pin+12V power cable connector.



## 3 Software Requirement

1. Computer running Windows 7, 8, 10, Server and or Linux based OS.
2. No driver is needed for the Host card, Target card and OSS-452 backplane.



## 4 Hardware Installation

The following steps will guide you through the installation of your OSS-452 board.

### 4.1 Installation-Procedures Overview

Below is the concise version on how to set up the OSS-452 board.

1. Connect ATX 24-pin Power Supply
2. Mount OSS-452 board
3. Plug-in 12V PSU Cable Connector
4. Install Target Card
5. Install Host Card
6. Connect link cable(s)
7. Attach Power Cord
8. Connect to Electrical Outlet
9. Power-ON host computer
10. Power Expansion Unit
11. Hardware Check
12. Verify Installation (via Operating System)
13. PCIe card Installation
14. PCIe HW Check or Verification



#### **NOTE**

It is highly recommended to install any 3<sup>rd</sup> party PCI-E cards / High Power PCIe cards after you have verified and tested the OSS expansion unit is working OK .

When installing 3<sup>rd</sup> Party PCIe card, start with one card first to determine if there are any software and hardware issues or incompatibility problems that may occur. This will help you in troubleshooting the problem more easily and efficiently. If everything works well and no configuration issues, you can proceed with the installation of the remaining 3<sup>rd</sup> party PCIe cards.

**Always refer to or read “3<sup>rd</sup> party manufacturer installation guide” for further instructions.**

## 4.2 Connect ATX 24-pin Power Cable

Flip the OSS-452 board to access the onboard power connector.

Locate the main ATX 24-pin power connector from the power supply. The connector is keyed, so verify that it is properly aligned with the female onboard connector on the OSS-452 backplane before you attempt to seat it.

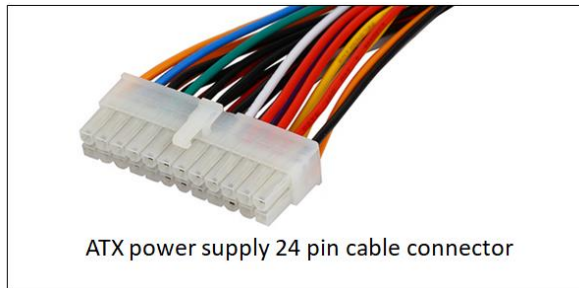
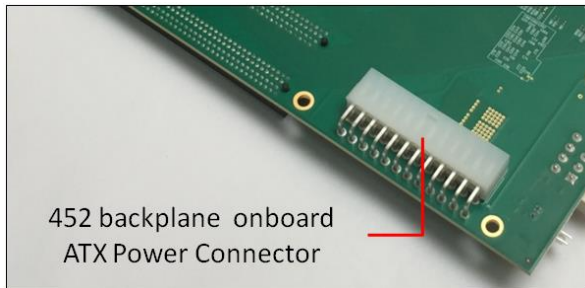

Once both connectors are aligned, press down firmly the connector until fully seated. You'll require a significant pressure to seat the connector and should snap into place. The locking tab on the side of the connector should snap into place over the corresponding nub on the socket.

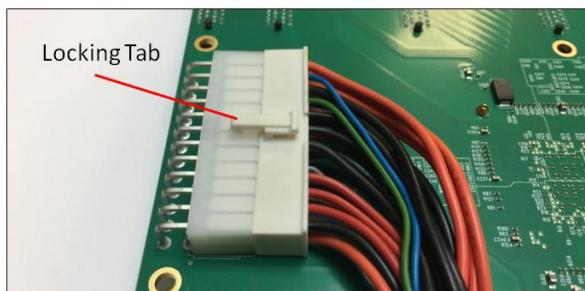

A partially seated main ATX power connector may cause intermittent power failure.

## 4.3 Mount OSS-452 board

If you have an enclosure, mount the OSS-452 board in the enclosure and secure it.



## 4.4 Plug-in 12V PSU Cable Connector

Locate the 8-pin 12V power connector from the power supply. Photo below is an example of 8-pin 12V power cable connector.



- The 8-pin 12V power connector is keyed to ensure proper mating with the 12V input power connector on the OSS-452 backplane.
- There are two available “12V input power connectors” on the OSS-452 backplane, you can use either one of the connectors. See photo below for the location of the 12V input power connectors.

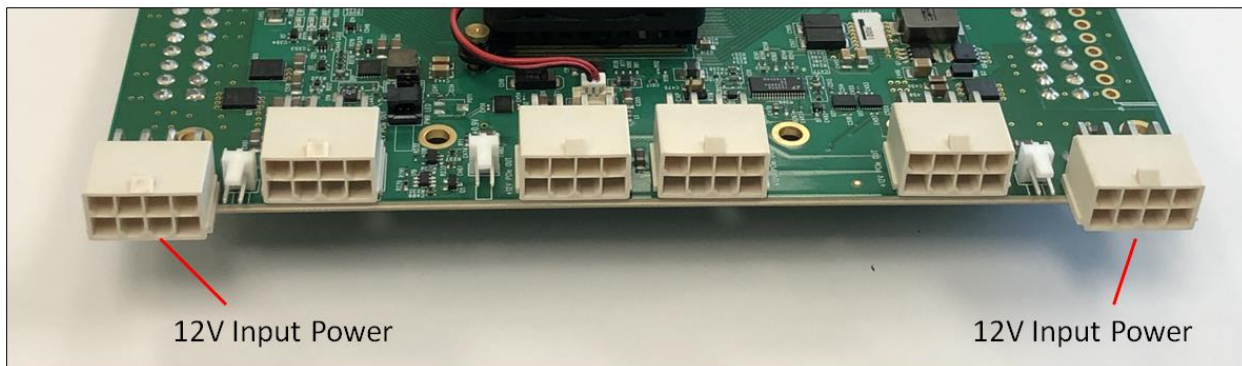

Once you have located the 12V power cable connector from the power supply, connect it to the 12V input power connector on the OSS-452 board.

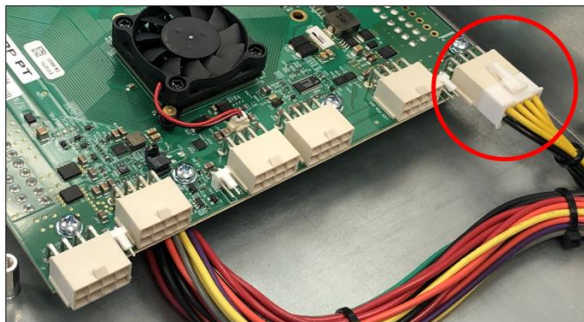

Next step is to install the target and host cards. The target card is installed in the OSS-452 backplane Upstream slot. The host card is placed in the host computer motherboard PCIe slot.

## 4.5 Install Target & Host Card

In this section an HIB38-x16 adapter is used as Target card.

**Note:** You can also use another x16 Gen3 adapter card such as OSS-PCIe-HIB68-x16. This particular card requires four HD Mini-SAS x4 cables (SFF-8644). For further information and instructions on how to install the OSS-PCIe-HIB68-x16 card please visit our website, <https://www.onestopsystems.com/cable-adapters>

Prior to installing the “Target card”, verify the Dipswitch SW1 is set to target mode. See photo below for the switch settings.

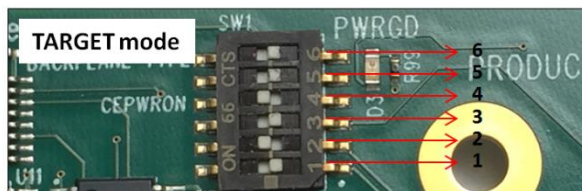
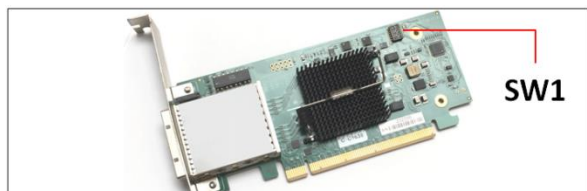

Once you have set the card to Target mode, install the card in the Upstream slot of the OSS-452 backplane.



## 4.6 Install Host Card

In this section an HIB38-x16 adapter is configured to operate in host mode.

**Note:** You can also use another x16 Gen3 adapter host card such as OSS-PCIe-HIB68-x16. This particular card requires four HD Mini-SAS x4 cables (SFF-8644). For further information and instructions on how to install the OSS-PCIe-HIB68-x16 card please visit our website, <https://www.onestopsystems.com/cable-adapters>

Before installing the Host adapter card into PCIe slot, check the SW1 Dip switch is set to host mode, see picture below for correct switch settings.

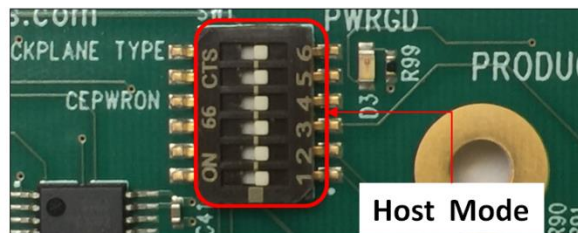
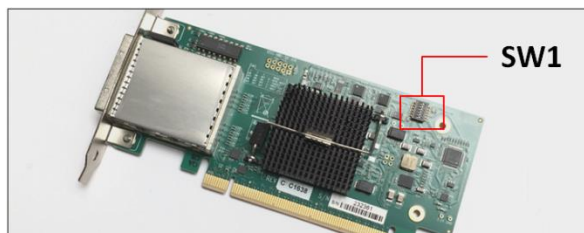



Once the switches are set to host mode, insert the host card into a vacant x16 PCIe slot by gently pushing the card until it is firmly seated then secure the card to the slot with a mounting screw, see next photos.

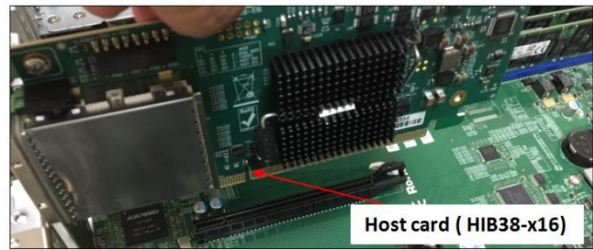
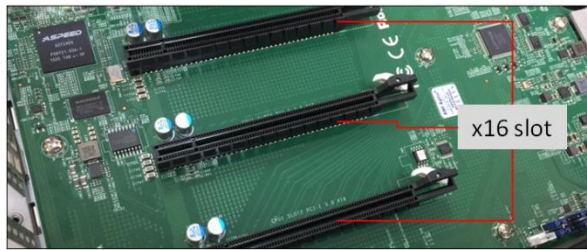
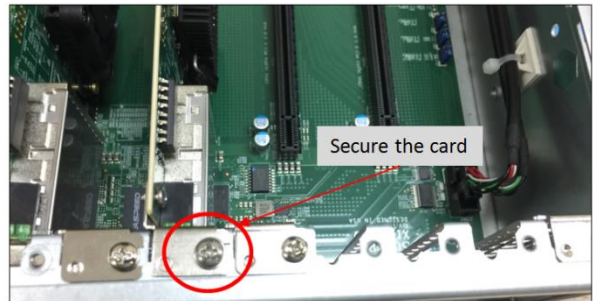
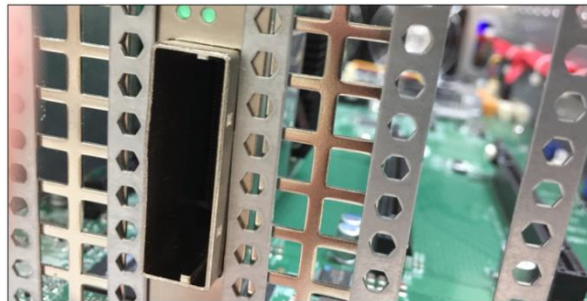

Photo below shows the cable port on OSS adapter card.



## 4.7 Connect Link Cable

In this section we are using an Ipass cable to link between host and target cards.

Push the "Latch Metal Tab" on the cable while slowly inserting it into the cable-port of the interface card.

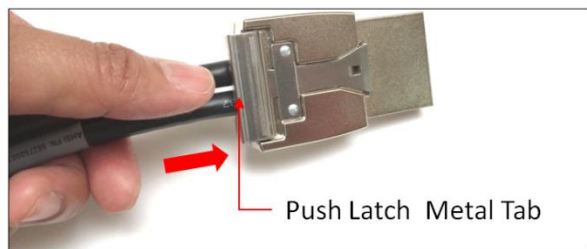

Carefully position the expansion chassis so that the supplied cable will conveniently reach from the host computer to the connectors on the back of the chassis. Then connect the cable to the OSS host card in the computer.

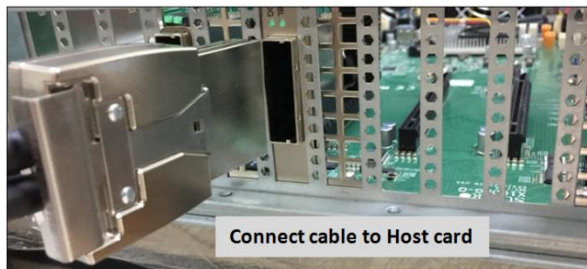

Connect the other one end of the cable to the target card.



Make sure the cables are fully secured, check the metal tab is fully latched onto holes of the card, see photos below. This will prevent the cable from being dislodged or disconnected from the card.

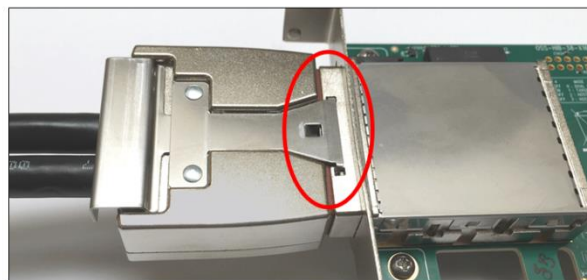
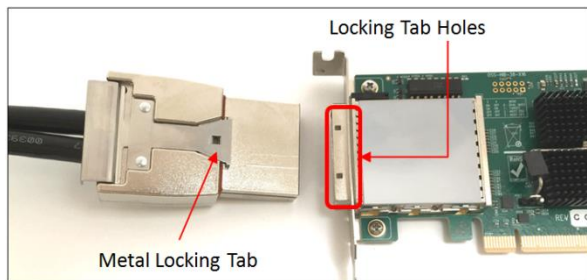

If you are using an OSS-PCIe-HIB68-x16, you would need to use four HD Mini-SAS x4 cables (SFF-8644). For further information and instructions on how to install the OSS-PCIe-HIB68-x16 card please visit our website, <https://www.onestopsystems.com/cable-adapters>

### 4.8 Connect Power Cord / Cable

Use a compatible and appropriate power cord. Plug the power cord into the back of the power supply receptacle. Ensure that the system's power supply unit is fully secured before connecting the power cord. Photos below are example of power cords that you can use.

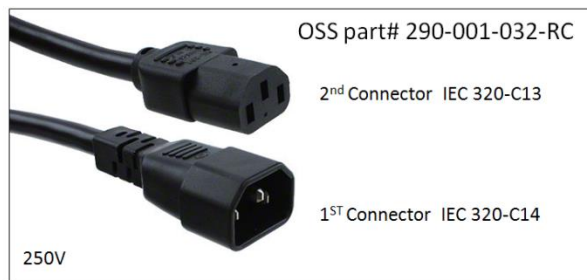
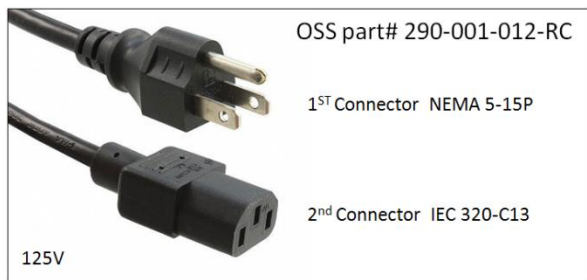

Power Cord Voltage Table

Power Cord	PSU Watt	Voltage	AMPS	Hz
125V	1000W	100-127V	12-9.5A	50-60Hz
250V	1800W	200-220V	10-9.5A	50-60Hz
250V	1980W	220-230v	10-9.8A	50-60Hz
250V	2000W	230-240V	10-9.8A	50-60Hz

NOTE: When using 115-125V power cord you are limited to 1000W of power.

## 4.9 Connect to Electrical Outlet

It is highly recommended using a power surge to protect your gear against random power spike damage.

- If you are using a 250V power cord, you would need to connect that to a PDU (power distribution unit). You can buy the PDU on any online electronic stores. OSS does not sell the PDU.

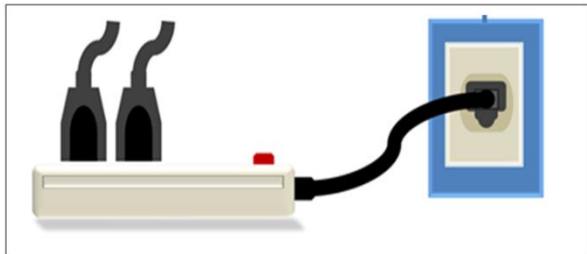

## 4.10 Power ON the Power Supply

Turn the power supply switch to ON position if your power supply unit has an ON/OFF switch. You can skip this step if the power supply does not have an ON/OFF switch.



## 4.11 Power ON the Host Computer

Before powering ON the Host computer, make sure the Host adapter card is seated correctly in the PCIe slot and the cable is firmly connected. Upon powering up the Host computer, the expansion board will turn ON automatically.

## 4.12 Power ON the Expansion Unit

When using the HIB38-x16 adapter card, the expansion system is switched ON automatically upon powering UP the Host system.

- A "Power On / Sideband" signal is sent to the cable initiating the expansion system to power ON.

## 5 Hardware Check

Once the host computer has booted up, check the expansion board and verify that all LEDs are correctly illuminated. An operational expansion board will show the following LEDs on the backplane and on the adapter cards.

1. LinkUP LED: Target card and Host card, CBL and EDG LEDs both should be illuminated as solid green.
2. Target Slot LED "D1" should be ON as solid green.

### 5.1 LinkUP LED (CBL & EDG)

The LED indicators (CBL & EDG) on both Target and Host cards will come up as solid green. This is an indication that a LINK between host and chassis has been established. The Linkup LEDs represent only an initial connection/handshake between the chassis and host computer. A successful linkup does not represent transfer or exchange of data.

1. The CBL LED shows the link status between the host card in the host computer and the target card in the expansion chassis.
2. The EDG / EDGE shows:
  - a. HOST card – connection between host card and host system
  - b. TARGET card – connection between the switch on the target card and the switch in the expansion chassis.



### 5.2 Target Slot & PWRGO LEDs

The "Target Slot LED" is located on the bottom part of PCIe slot. This LED (D1) should be ON as solid green. This represents that Link is up at Gen 3 speed. The PWRGO LED, signifies that the card is powered UP correctly.

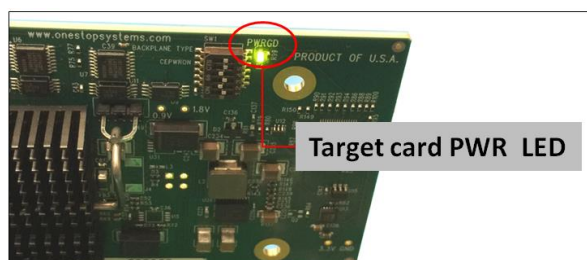
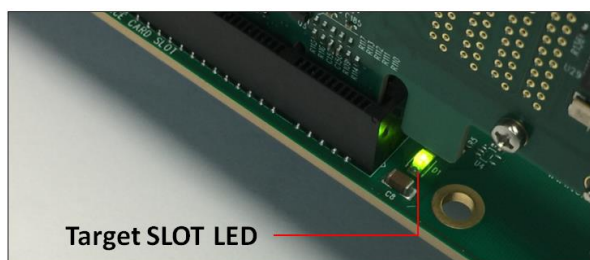



## 6 Check OSS Device on Windows

### 6.1 How to verify OSS Device on Windows OS

Verify hardware device in Windows Operating System. As your Windows computer starts up, you will see a small message box pop-up in the lower-right corner of the screen to alert you that Windows has found new hardware.

To verify a successful installation on Windows, find the 'My Computer' icon and "right-click" on it. Then select 'Manage' from the pop-up menu. Next, click on 'Device Manager' in the leftmost Computer Management window. Finally, click on the View Menu and select View Devices by Connection.

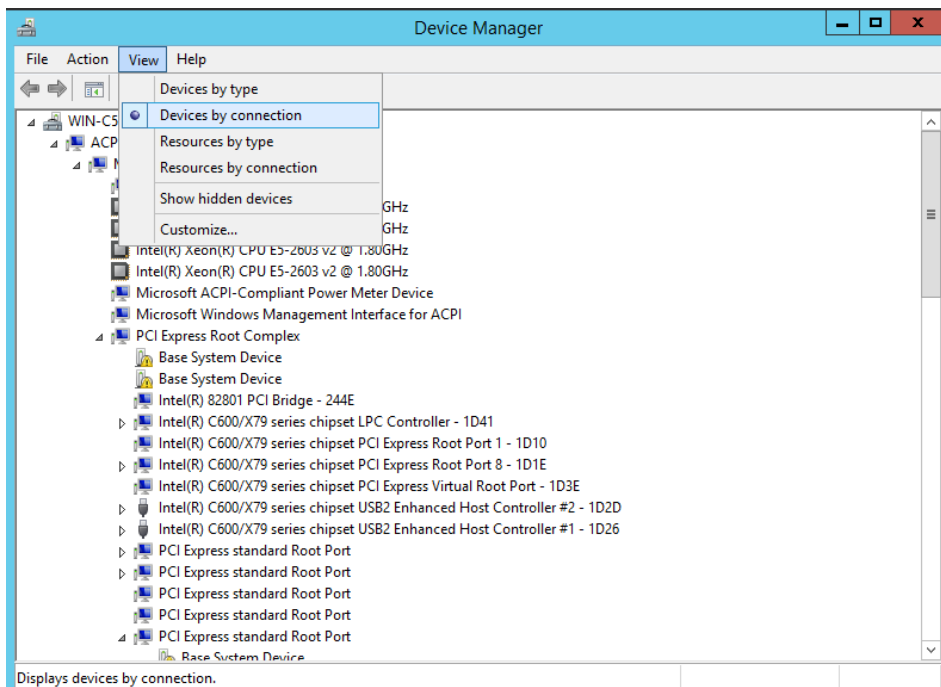

Open ACPI (BIOS) → Open PCI Bus → Click the '+' sign several times until you reach a PCI Express Root Port Complex with PCI Express standard Upstream Switch Port and PCI Express standard Downstream Switch Port.

When installed properly, you will see ten PCI Express standard Downstream Switch Ports below the PCI Express standard Upstream Switch Ports. The screenshot below represent the structure of one expansion board attached to a specific host computer. It is either the 1<sup>st</sup> or 2<sup>nd</sup> backplane is attached to a specific host computer.

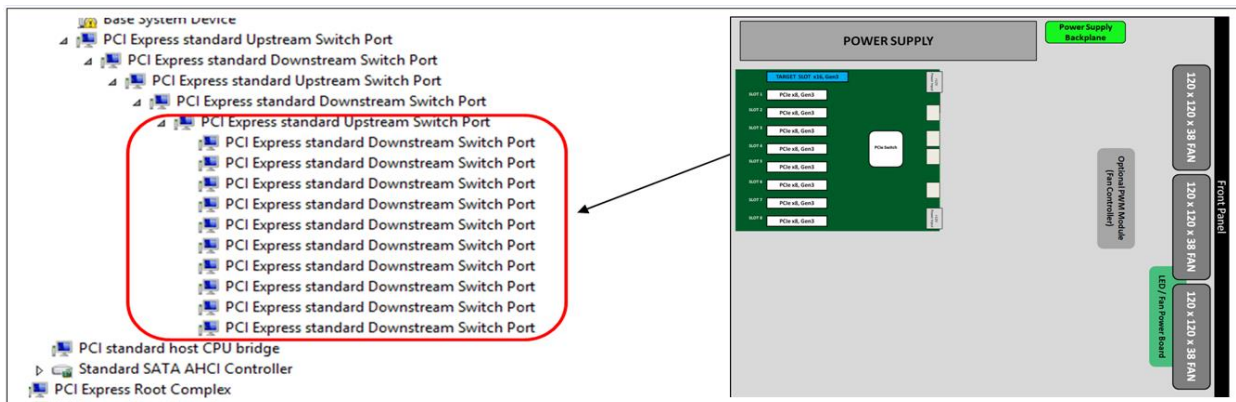

## If the verification is successful, you may now proceed to installing your 3<sup>rd</sup> Party PCIe Cards.

NOTE: If you are not seeing ten PCI Express standard Downstream Switch Ports (as shown from the above photos) in Windows Device Manager, it means the host computer is not recognizing or detecting the board. You may be having “faulty host card or target card” and “or may be having an intermittent backplane failure. For troubleshooting, try the following :

- Verify 2x PCIe x16 cables is firmly connected on both ends
- Verify Host/Target cards are firmly seated in both Host and 4UV Chassis
- Verify power is being properly applied to both Host and 4UV Chassis
- Verify LEDs are illuminated properly on 4UV Chassis
- Verify Dipswitch settings on Host/Target cards
- If the issue is not resolved, contact OSS customer support

## 6.2 How to verify OSS Device on Linux OS

On a Linux based system, the installation can be verified by typing the following command lines:

- **lspci -t** Displays the overall structure of the PCIe expansion system
- **lspci -vv** Lists additional information about the PCIe switch (in our case it will list the Integrated Device Technology (IDT) information.
- **lspci -vvv** Displays the most comprehensive information about the expansion system.

Typical output from `lspci -vvv` is verbose, but you can dig through the information to find very important information. There are so many registers and settings associated with PCI Express Switches.

Use the “`lspci | grep “8796”`” command to check that the One Stop Systems card and slot devices are detected (see image below). Broadcom PLX is the PCIe switch (component) on the One Stop Systems expansion board.

```
[root@sca05-0a81fd86 Documents]# lspci | grep 8796
17:00.0 PCI bridge: PLX Technology, Inc. Device 8796 (rev ab)
18:00.0 PCI bridge: PLX Technology, Inc. Device 8796 (rev ab)
18:01.0 PCI bridge: PLX Technology, Inc. Device 8796 (rev ab)
18:08.0 PCI bridge: PLX Technology, Inc. Device 8796 (rev ab)
18:09.0 PCI bridge: PLX Technology, Inc. Device 8796 (rev ab)
18:0c.0 PCI bridge: PLX Technology, Inc. Device 8796 (rev ab)
18:0d.0 PCI bridge: PLX Technology, Inc. Device 8796 (rev ab)
18:10.0 PCI bridge: PLX Technology, Inc. Device 8796 (rev ab)
18:11.0 PCI bridge: PLX Technology, Inc. Device 8796 (rev ab)
18:14.0 PCI bridge: PLX Technology, Inc. Device 8796 (rev ab)
18:15.0 PCI bridge: PLX Technology, Inc. Device 8796 (rev ab)
[root@sca05-0a81fd86 Documents]#
```

The first PCI Bridge in this example is the Upstream Port.

```
[root@sca05-0a81fd86 Documents]# lspci | grep 8796
17:00.0 PCI bridge: PLX Technology, Inc. Device 8796 (rev ab)
18:00.0 PCI bridge: PLX Technology, Inc. Device 8796 (rev ab)
18:01.0 PCI bridge: PLX Technology, Inc. Device 8796 (rev ab)
18:08.0 PCI bridge: PLX Technology, Inc. Device 8796 (rev ab)
18:09.0 PCI bridge: PLX Technology, Inc. Device 8796 (rev ab)
18:0c.0 PCI bridge: PLX Technology, Inc. Device 8796 (rev ab)
18:0d.0 PCI bridge: PLX Technology, Inc. Device 8796 (rev ab)
18:10.0 PCI bridge: PLX Technology, Inc. Device 8796 (rev ab)
18:11.0 PCI bridge: PLX Technology, Inc. Device 8796 (rev ab)
18:14.0 PCI bridge: PLX Technology, Inc. Device 8796 (rev ab)
18:15.0 PCI bridge: PLX Technology, Inc. Device 8796 (rev ab)
[root@sca05-0a81fd86 Documents]#
```

Upstream Port

The 'Downstream' ports are the remaining are the PCIe slots.

```
[root@sca05-0a81fd86 Documents]# lspci | grep 8796
17:00.0 PCI bridge: PLX Technology, Inc. Device 8796 (rev ab)
18:00.0 PCI bridge: PLX Technology, Inc. Device 8796 (rev ab)
18:01.0 PCI bridge: PLX Technology, Inc. Device 8796 (rev ab)
18:08.0 PCI bridge: PLX Technology, Inc. Device 8796 (rev ab)
18:09.0 PCI bridge: PLX Technology, Inc. Device 8796 (rev ab)
18:0c.0 PCI bridge: PLX Technology, Inc. Device 8796 (rev ab)
18:0d.0 PCI bridge: PLX Technology, Inc. Device 8796 (rev ab)
18:10.0 PCI bridge: PLX Technology, Inc. Device 8796 (rev ab)
18:11.0 PCI bridge: PLX Technology, Inc. Device 8796 (rev ab)
18:14.0 PCI bridge: PLX Technology, Inc. Device 8796 (rev ab)
18:15.0 PCI bridge: PLX Technology, Inc. Device 8796 (rev ab)
[root@sca05-0a81fd86 Documents]# █
```

Downstream Port

## 7 PCIe Cards Installation

### 7.1 Install PCIe card(s)

Be sure to install the PCIe cards following the card manufacturer’s recommendations. Some PCIe card manufacturers recommend that you install their software driver(s) prior to installing the hardware. If this is the case, you should install their driver or software before you connect and power up the expansion chassis.

The backplane PCIe slot can accommodate x2, x4, x8 and x16 PCIe cards. You can combine or mix different types of PCIe cards. For example, you can install 8 PCIe nvme cards on the 1<sup>st</sup> backplane and FPGA cards on the 2<sup>nd</sup> board.

To install PCIe card, align the card on top of the slot. Gently push the card down until it is firmly seated. Make sure that all PCIe cards are secured.

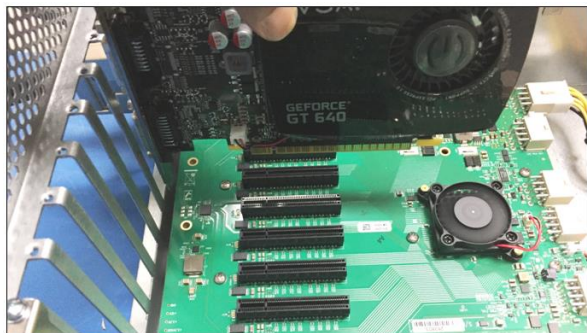

To keep the cards in place, secure them in the enclosure with their retaining screws.

### 7.2 PCIe Cards Combination

The following photos are few examples of different combinations of PCIe cards that you can install in the 8-slot expansion board.

Sample 1: All PCIe slots are populated with x8 single-wide GPU cards.

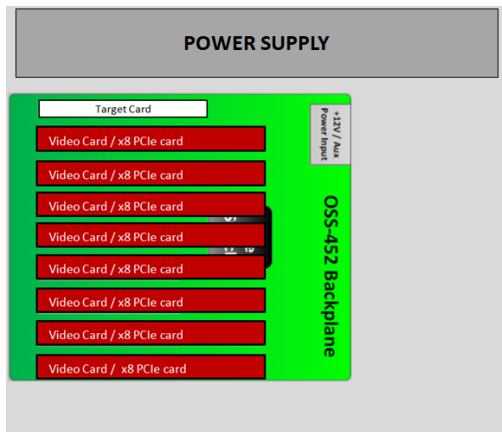

Sample 2: All PCIe slots are populated with SSD NVME PCIe cards

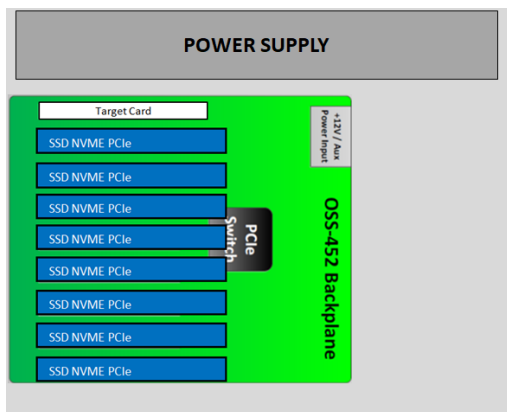

Sample 3: Populated with mixed x8 and x4 PCIe cards.

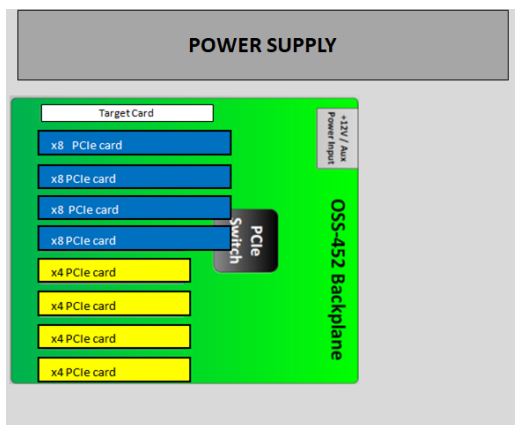

**IMPORTANT**

The sheer number of PCIe cards and device drivers available makes it impossible for One Stop Systems to fully test and certify all available PCIe cards for use in the One Stop Systems expansion chassis. Our best advice to you in this regard is to insist on full PCIe Specification compliance from your card and system vendors. Cards and systems should be at least PCIe Specification Revision 1.0 compliant or better. Compliance in your system motherboard, PCIe cards, and console firmware (or BIOS) is your best assurance that everything will install and operate smoothly.

- **This particular expansion board is not applicable to run a double-wide x16 GPUs.**
- If you are planning to use a full length x16 double-wide GPUs, you need a different expansion unit. The solution is to use the “4U Value GPU Accelerator System (Model:OSS-PCIe-4UV-10-2), which is capable of running multiple high-end GPU application.
- Contact our Sales Team to find out more info on this product.

## 8 Verify or Check PCIe Devices

This section provides information on how to check / verify your PCIe cards on Windows OS and Linux. Use the following information for checking all of your PCIe cards installed in the OSS-452 expansion board are recognized or detected by the operating systems.

### 8.1 Verify PCIe Hardware

After the system is powered up, check inside the unit and pay attention on the slot LEDs.

- You should see all LEDs are illuminated, see pictures below. This is an indication that a card in the slot is recognized and detected.
- Depending on the type of PCIe card that is present in the slot will dictate the LED behavior.
- If there is no card present in the slot, the slot LED will be OFF.

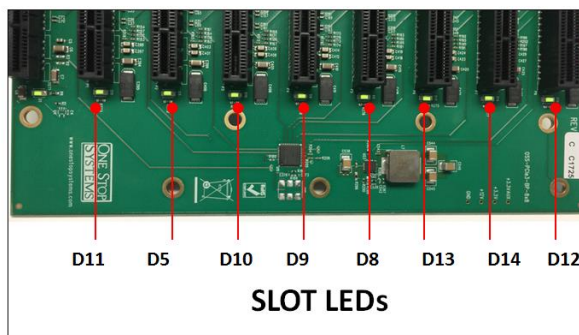

#### 8.1.1 Slot LED Status indicators

- Off - Link is down; no PCIe card installed
- Slow blink - Link is up at Gen1 (1Hz)
- Fast blink - Link is up at Gen2 (2Hz)
- On (solid) - Link is up at Gen3 speed

Check the LINK LEDs on both Host and Target cards.

- Make sure you have a solid green LEDs on CBL and EDG.
- If only one LED is lit, this is an indication that you are not getting a good link between host and expansion unit. If this occurs, the host computer will not be detecting or recognizing your PCIe cards in the expansion unit.





## 8.2 Check PCIe cards on Windows OS

When everything is functioning correctly, your Windows Device Manager should look something like the screenshot below. It represents one expansion board / backplane attached to one specific host computer.

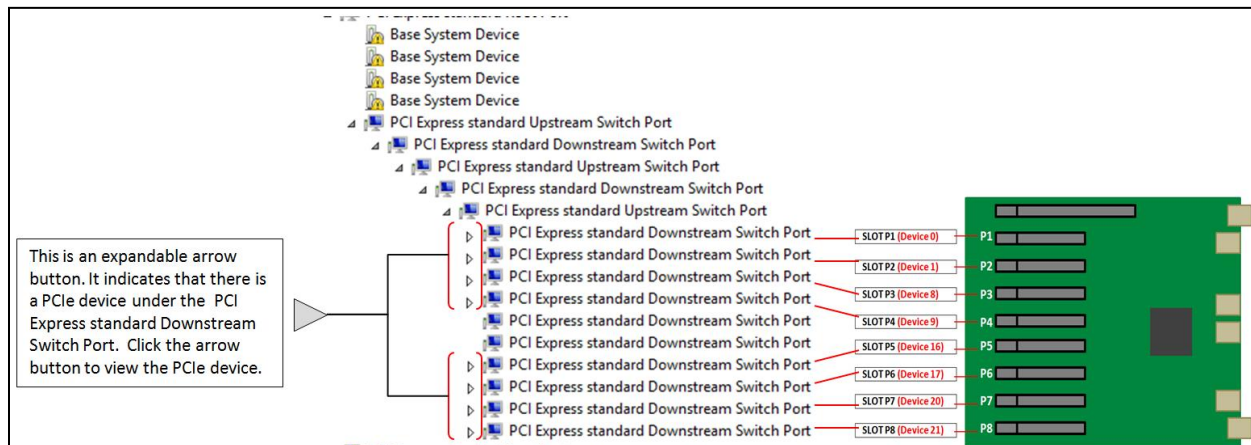

Expanding the arrow button will reveal the detected PCIe device or PCIe card beneath the PCI Express standard Downstream Switch Port. The example photo below shows eight PCIe cards that are detected and no errors (no yellow exclamation point). This means all the PCIe cards are working correctly.

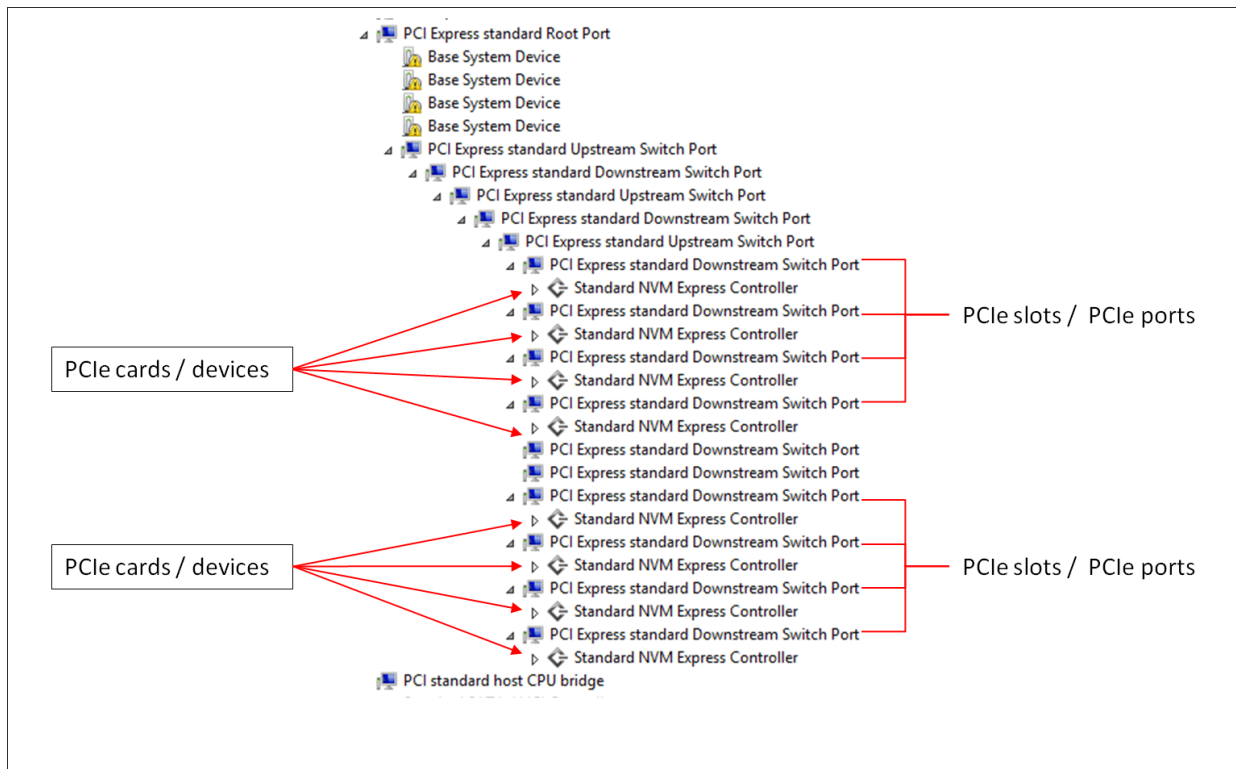





## 9 Contacting Technical Support

Our support department can be reached by fax at (858) 530-2733 or by phone at (858) 530-2511. Support is available Monday through Friday, 8:00 AM to 5:00 PM PT. When contacting One Stop Systems Technical Support, please be sure to include the following information:

- |                  |  |
|------------------|--|
| 1) Name          | 7) Serial Number                                 |
| 2) Company Name  | 8) Computer Make                                 |
| 3) Phone Number  | 9) Computer Model                                |
| 4) Fax Number    | 10) Operating System and Version                 |
| 5) Email Address | 11) Make/Model of PCI cards in expansion chassis |
| 6) Model Number  | 12) Detailed description of the problem          |

You can also visit our web site at: <https://www.onestopsystems.com/support-0>

To submit a support ticket or case, use our OSS Online Support portal: <https://onestopsystems.desk.com/customer/portal/emails/new>

For a quick response, use the Technical Support and RMA Request Form available in the Support Section of the website. Simply complete the form with all required information. Please make sure that your problem description is sufficiently detailed to help us understand your problem. For example: Don't say "Won't boot up." Do say "Tried all the steps in the Troubleshooting Section and it still won't boot up."

For faster diagnosis of your problem, please run the two utility programs described in the following sections and include the diagnostic files they generate with your email.

## 10 Returning Merchandise to One Stop Systems

If factory service is required, you must contact OSS Service Representative to obtain a Return Merchandise Authorization (RMA) number. Put this number and your return address on the shipping label when you return the item(s) for service. **One Stop Systems will return any product that is not accompanied by an RMA number.** Please note that One Stop Systems WILL NOT accept COD packages, so be sure to return the product freight and duties-paid.

Ship the well-packaged product to the address below:

RMA # \_\_\_\_\_  
One Stop Systems  
2235 Enterprise Street, Suite#110  
Escondido, CA 92029  
USA

It is not required, though highly recommended, that you keep the packaging from the original shipment of your One Stop Systems product. However, if you return a product to One Stop Systems for warranty repair/ replacement or take advantage of the 30-day money back guarantee, you will need to package the product in a manner similar to the manner in which it was received from our plant. One Stop Systems cannot be responsible for any physical damage to the product or component pieces of the product (such as the host or expansion interfaces for the PCIe expansion chassis) that are damaged due to inadequate packing. Physical damage sustained in such a situation will be repaired at the owner's expense in accordance with Out of Warranty Procedures. Please, protect your investment, a bit more padding in a good box will go a long way to insuring the device is returned to use in the same condition you shipped it in. Please call for an RMA number first.

## 11 Shipping / transporting the unit

GPU cards should be removed from the slots when transporting or shipping the unit as this can break the slot and damage the card.



### IMPORTANT

PCIe cards should be removed (or not to be installed) prior to shipping to avoid or prevent possible damage, failure to do so, will void the warranty of the unit..

---

## 12 APPENDIX A Compliance

### FCC

NOTE: This equipment has been tested and found to comply with the limits for a Class A digital device, pursuant to part 15 of the FCC Rules. These limits are designed to provide reasonable protection against harmful interference when the equipment is operated in a commercial environment. This equipment generates, uses, and can radiate radio frequency energy and, if not installed and used in accordance with the instruction manual, may cause harmful interference to radio communications. Operation of this equipment in a residential area is likely to cause harmful interference in which case the service personnel will be required to correct the interference at his own expense. This device complies with Part 15 of the FCC Rules. Operation is subject to the following two conditions: (1) this device may not cause harmful interference, and (2) this device must accept any interference received including interference that may cause undesired operation. Changes or modifications not expressly approved by the party responsible for compliance could void the service personnel's authority to operate the equipment.

---



### NOTE

The assembler of a personal computer system may be required to test the system and/or make necessary modifications if a system is found to cause harmful interferences or to be noncompliant with the appropriate standards for its intended use.

---

Industry Canada

This Class A digital apparatus complies with Canadian ICES-003. Cet appareil numérique de la classe A est conforme à la norme NMB-003 du Canada

### CE

The product(s) described in this manual complies with all applicable European Union (CE) directives. One Stop Systems will not retest or recertify systems or components that have been reconfigured by customers



**2235 Enterprise Street, Suite#110, Escondido CA 92029**

Toll-Free : +1(800)285-8900 US • Main: +1 (760) 745-9883 • Fax: +1 (760) 745-9824

**[www.onestopsystems.com](http://www.onestopsystems.com)**