



# 4U Value 8-Slot Gen 3

8 PCIe (3.0x8) Slot Expansion System



## User Manual

SKU: OSS-PCIE-4UV-8-1



**OSS**  
ONE STOP SYSTEMS

[www.onestopsystems.com](http://www.onestopsystems.com)

# Table of Contents

<b>Preface.....</b>	<b>6</b>
Advisories .....	6
Safety Instructions .....	7
Protecting Against Electrostatic Discharge .....	8
<b>1 Introduction.....</b>	<b>9</b>
1.1 General Specifications.....	9
1.2 Features .....	10
1.3 Block Diagram .....	10
1.3.1 Enclosure.....	10
1.3.2 Backplane .....	10
1.3.3 Host and backplane .....	11
1.4 Supported Configuration.....	11
1.5 Main Components.....	12
1.6 Parts .....	13
1.7 Pre-Installation Information.....	14
1.8 Tools Required for Installation .....	14
1.9 Items List .....	14
<b>2 Hardware Set-up / Installation .....</b>	<b>15</b>
2.1 Installation-Procedures Overview .....	16
2.2 Before you Begin.....	16
2.3 Remove Top Cover .....	16
2.4 Install Target Card .....	17
2.5 Install Host Interface Cards .....	18
2.5.1 Installation of host card in a server using a “Riser Card” .....	20
2.6 Connect Link Cable .....	21
<b>3 Applying Power Correctly.....</b>	<b>22</b>
3.1 Connect Power Cord / Cable .....	22
3.2 Connect power cord to electrical outlet.....	22
3.3 Power ON the Host Computer .....	23
3.4 Power ON the Expansion Unit .....	23
<b>4 Hardware Check.....</b>	<b>24</b>
4.1 LinkUP LED (CBL & EDG).....	24
4.2 Target Slot & PWRGO LEDs .....	24
4.3 Re-install Top Cover .....	25
4.4 Front LEDs Status Indicator .....	25
4.5 Power Supply LED Indicator .....	26
<b>5 Software Installation.....</b>	<b>27</b>

5.1	Software Driver Installation .....	27
5.2	Verify Systems Installation .....	27
5.2.1	How to verify system on Windows OS (Windows Server) .....	27
5.2.3	PCIe slot and Device ID assignment .....	29
5.2.4	How to verify Expansion device in Linux OS .....	33
5.2.5	PCIe slot and Port# assignment .....	34
5.2.6	Linux Commands to check on expansion device.....	35
<b>6</b>	<b>PCIe cards Installation .....</b>	<b>39</b>
6.1	Power Down System .....	39
6.2	Open PCIe Expansion Chassis .....	39
6.3	Install PCI Express (PCIe) Cards .....	40
6.4	Re-install top cover .....	43
6.5	Apply Power.....	43
<b>7</b>	<b>PCIe HW &amp; SW Verification .....</b>	<b>44</b>
7.1	Verify PCIe Hardware .....	44
7.1.1	Slot LED Status indicators .....	44
7.2	Check PCIe cards on Windows OS .....	45
7.3	Check PCIe cards on Linux OS.....	47
7.4	Check PCIe cards on Mac OS .....	51
<b>8</b>	<b>General &amp; Other Technical Information.....</b>	<b>52</b>
8.1	Target and Host cards .....	52
8.1.1	Specifications .....	52
8.1.2	Dimension .....	53
8.1.3	Card LEDs .....	53
8.1.4	Card Mode Settings .....	54
8.1.6	Pin Assignments .....	54
8.1.7	Pin-out for the Gen3 PCIe x16 Card Edge Connector.....	54
8.2	452 Backplane.....	56
8.2.1	PCIe Slots and Ports Assignment .....	56
8.2.2	Dimension .....	56
8.2.3	Parts 452 backplane .....	57
8.2.4	Card Slot Link LEDs .....	58
8.2.5	Slot Type.....	58
8.2.6	Force Power ON .....	59
8.2.7	Connector Pin-Outs .....	60
8.3	Using Fiber Optic Cables and HIB68-x16 card .....	61
8.4	Power Cords.....	63
8.4.1	Specifications .....	63
8.4.2	Power cord socket and voltage tables world standards .....	63
8.5	Link Cable .....	64

8.5.1	Specifications .....	64
8.5.2	Cable Installation.....	65
8.5.3	Cable Removal.....	65
8.5.4	Cable Pin-Outs Assignment .....	66
8.6	Power Supply .....	67
8.6.1	Removing a hot-swap ac power supply .....	67
8.5.2	Specifications .....	68
8.6.3	LED Indicator .....	69
8.7	Fan .....	70
8.7.1	Fan Specifications.....	70
8.8	Auxiliary power cables .....	71
8.8.1	Aux power cable installation .....	71
8.8.2	Pinouts .....	73
8.8.3	Using the Auxiliary Power Cable.....	75
8.9	Power Consumption.....	77
8.8.1	Power consumption breakdown per hardware.....	77
<b>9</b>	<b>Fan Controller .....</b>	<b>78</b>
9.1	4-wire Fan vs. 3-wire Fan .....	79
9.2	Specifications .....	80
<b>10</b>	<b>Troubleshooting.....</b>	<b>81</b>
10.1	Locating the Problem.....	81
10.2	My Computer Cannot Find the PCIe Expansion System.....	82
10.3	My Computer Hangs During Power Up.....	83
10.4	My PCIe Card Doesn't Work .....	83
10.5	Support for 3P <sup>rd</sup> Party PCIe Cards .....	84
10.6	PCIe card Memory Requirements .....	85
<b>11</b>	<b>Rackslide Installation .....</b>	<b>86</b>
<b>12</b>	<b>Enclosure Dimensions .....</b>	<b>88</b>
<b>13</b>	<b>Rackslide Mounting Position .....</b>	<b>89</b>
<b>14</b>	<b>Frequently Asked Questions (FAQ).....</b>	<b>90</b>
<b>15</b>	<b>Contacting Technical Support .....</b>	<b>92</b>
<b>16</b>	<b>Returning Merchandise to One Stop Systems .....</b>	<b>92</b>
<b>17</b>	<b>APPENDIX A Compliance.....</b>	<b>93</b>
	FCC .....	93
	CE .....	93



# Preface

## Advisories

Five types of advisories are used throughout this manual to provide helpful information, or to alert you to the potential for hardware damage or personal injury.

**NOTE**

Used to amplify or explain a comment related to procedural steps or text.

**IMPORTANT**

Used to indicate an important piece of information or special “tip” to help you

**CAUTION**

Used to indicate and prevent the following procedure or step from causing damage to the equipment.

**WARNING**

Used to indicate and prevent the following step from causing injury.

**DANGER or STOP**

Used to indicate and prevent the following step from causing serious injury or significant data loss

Disclaimer: We have attempted to identify most situations that may pose a danger, warning, or caution condition in this manual. However, One Stop Systems does not claim to have covered all situations that might require the use of a Caution, Warning, or Danger indicator.

## Safety Instructions

Always use caution when servicing any electrical component. Before handling the One Stop Systems Expansion chassis, read the following instructions and safety guidelines to prevent damage to the product and to ensure your own personal safety. Refer to the “Advisories” section for advisory conventions used in this manual, including the distinction between Danger, Warning, Caution, Important, and Note.

Always use caution when handling/operating the computer. Only qualified, experienced, authorized electronics personnel should access the interior of the computer and expansion chassis.



### **WARNING**

Never modify or remove the radio frequency interference shielding from your workstation or expansion unit. To do so may cause your installation to produce emissions that could interfere with other electronic equipment in the area of your system.

### When Working Inside a Computer

Before taking covers off a computer, perform the following steps:

Turn off the computer and any peripheral devices.

Disconnect the computer and peripheral power cords from their AC outlets or inlets in order to prevent electric shock or system board damage.

In addition, take note of these safety guidelines when appropriate:

To help avoid possible damage to systems boards, wait five seconds after turning off the computer before removing a component, removing a system board, or disconnecting a peripheral device from the computer.

When you disconnect a cable, pull on its connector or on its strain-relief loop, not on the cable itself. Some cables have a connector with locking tabs. If you are disconnecting this type of cable, press in on the locking tabs before disconnecting the cable. As you pull connectors apart, keep them evenly aligned to avoid bending any connector pins. Also, before connecting a cable, make sure both connectors are correctly oriented and aligned.



### **CAUTION**

Do not attempt to service the system yourself except as explained in this manual. Follow installation instructions closely.

## Protecting Against Electrostatic Discharge



### **Electrostatic Discharge (ESD) Warning**

Electrostatic Discharge (ESD) is the enemy of semiconductor devices. You should always take precautions to eliminate any electrostatic charge from your body and clothing before touching any semiconductor device or card by using an electrostatic wrist strap and/or rubber mat.

Static electricity can harm system boards. Perform service at an ESD workstation and follow proper ESD procedures to reduce the risk of damage to components. One Stop Systems strongly encourages you to follow proper ESD procedures, which can include wrist straps and smocks, when servicing equipment.

You can also take the following steps to prevent damage from electrostatic discharge (ESD):

When unpacking a static-sensitive component from its shipping carton, do not remove the component's anti-static packaging material until you are ready to install the component in a computer. Just before unwrapping the anti-static packaging, be sure you are at an ESD workstation or are grounded.

When transporting a sensitive component, first place it in an anti-static container or packaging.

Handle all sensitive components at an ESD workstation. If possible, use anti-static floor pads and workbench pads.

Handle components and boards with care. Do not touch the components or contacts on a board. Hold a board by its edges or by its metal mounting bracket.



# 1 Introduction

## 1.1 General Specifications

Item	Description
Host Card:	The system includes one PCIe 3.0x16 host & target interface cards for connecting the accelerator to any server. HIB38-x16 Host/Target Interface cards Half Height, half length, single slot x16 PCIe add-in card form factor PCIe3 x16 physical card edge connector (128Gbps)
Backplane:	One 452 OSS-PCIe3-BP-8Slot-8x8 (PCIe 3 8-slot expansion backplane) The 8-slot integrated system includes: - One HIB38x16 PCIe cable and target interface card - Eight PCIe3 x8 single-width slots
Enclosure:	- Supports up to 8 full-height, full-length PCIe slots plus 1 cable interfaces - Supports extended height cards and top GPU power cables. - Black medium texture liquid paint finish with optional OEM logo area. - Power and Fan status bi-color LED panel - Tool-less rack slides included
Dimensions:	19" W x 7" H x 17.7" D
Weight:	30.0 lbs without the baseboard (452/457) or add-in cards
PCI Express Bus Spec.	Revision 3.0
Interconnect Bandwidth:	15.8 GB/s (16000 MB/s) Theoretical Throughput of the expansion unit, Gen 3.0 @ x16
Cooling:	Three 120mm x 38mm fans mounted to the front bezel of the chassis Two standard fan options available: High-Capacity Fans: - 250CFM fixed-speed fans - Fan monitoring via front panel LED  Variable Speed PWM Fans: - 250CFM PWM controlled fans - Set and forget PWM speed control module internal to the enclosure
Power Supply:	Dual load-sharing power supplies pluggable from the rear of the chassis: - Two 2000W 80Plus Titanium efficiency power supplies - Two integrated 90-264VAC, AC inputs (one in each supply) 100-140VAC at 1000W 200-240VAC at 2000W - Power supplies can provide up to 4000W non-redundant total power to the system - Supplies are redundant hot-swap when system power requirements are under 2000W total Aux Power: - An array of 8 EPS12V AUX power connectors available for high-power cards
MTBF:	53,000 hours
Operating Environment:	0-35°C 10-90% relative humidity 0-10,000 feet above sea level
Storage Environment:	-40 to 85°C 5-96% relative humidity 0-50,000 feet above sea level
Operating Systems:	Microsoft Windows Operating Systems and Linux base OS
Agency Compliance	Agency Certifications (testing pending) FCC Class A CE Safety & Emissions UL, cUL RoHS2
Warranty:	1 Year Return to Factory. Extended Warranty is available and sold separately. Upon purchased of a new unit you can buy an extended warranty.

## 1.2 Features

- 4U rackmount design
- 8 PCIe 3.0 x8 expansion slots
- One PCIe 3.0 x16 host connection
- One PCIe 1m or 2m cables
- PWM fan options
- Two 2000W load-sharing power supplies or Single
- AUX power connectors for high power AICs

## 1.3 Block Diagram

### 1.3.1 Enclosure

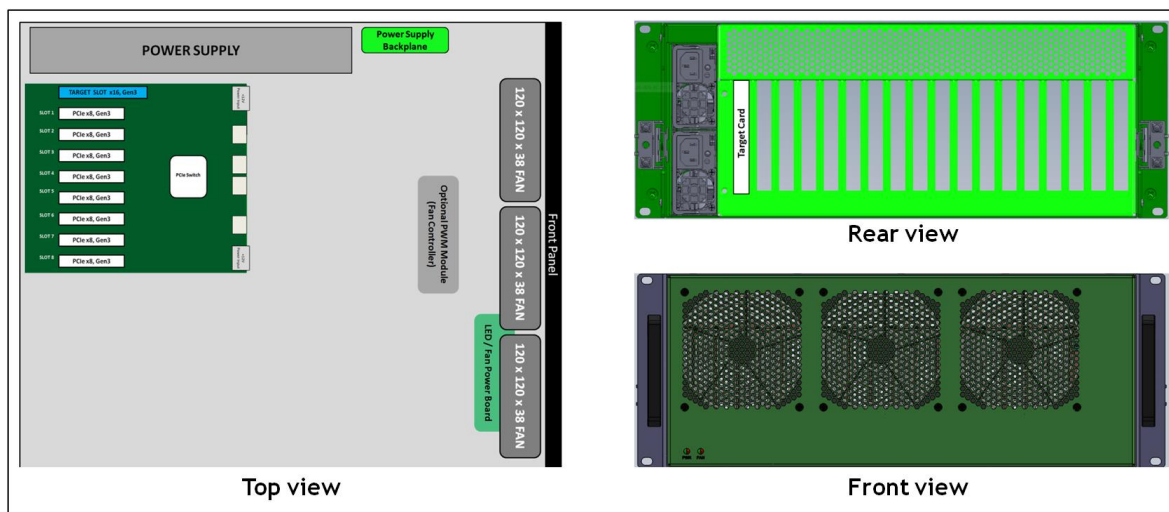

### 1.3.2 Backplane

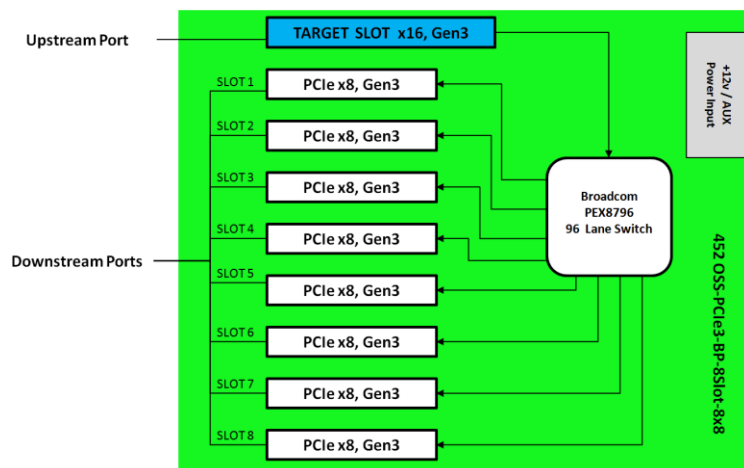

### 1.3.3 Host and backplane

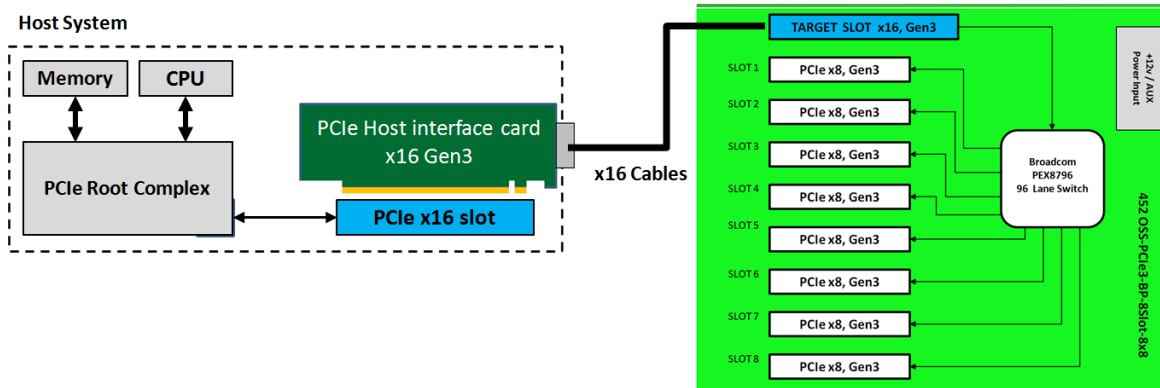

### 1.4 Supported Configuration

Attached to one host server / computer. One Cable adapter card installed in the host and 1 target card in the expansion unit.

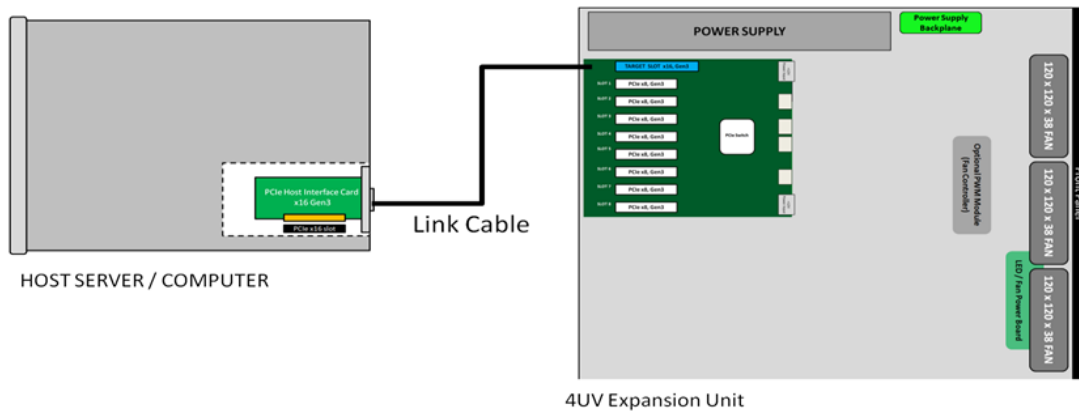

OR

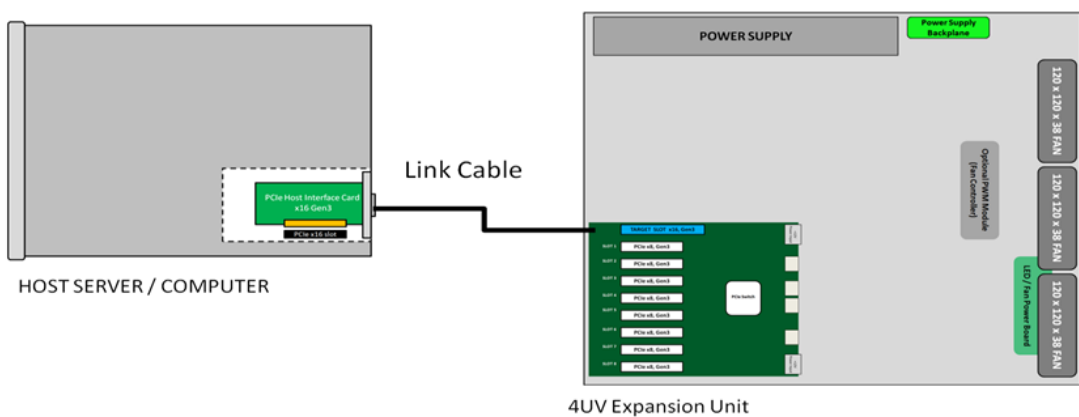

## 1.5 Main Components

The 4u Value chassis 8-slot expansion is composed of following major components

1. One 8-slot Backplanes
2. One Target Card : PCIe 3.0 x16
3. One Host Card: PCIe 3.0 x16
4. One PCIe Cables
5. Two 2000W Power Supplies or Single
6. Three 120mm x 38mm Fans (250cfm)

## 1.6 Parts

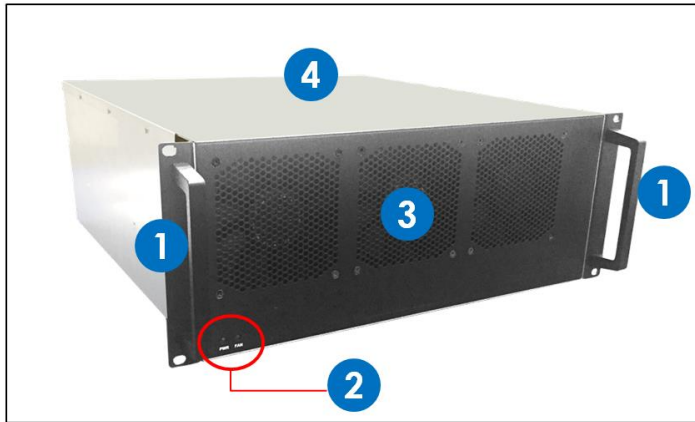

Item#	Description
1	Front Handles
2	Power and Fan LED indicators
3	Front Grill / Cover
4	Top Cover

### FRONT VIEW

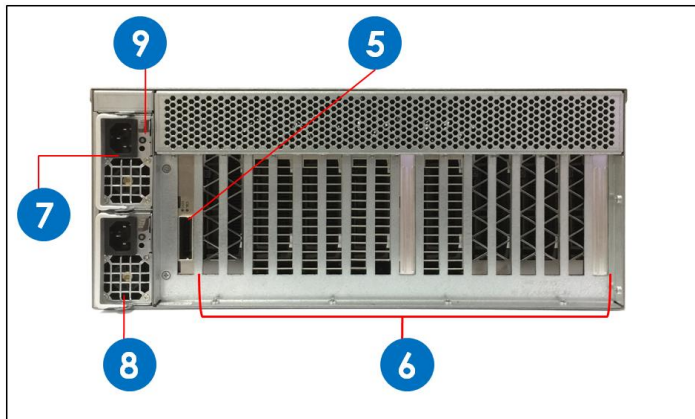

Item#	Description
5	Target Card
6	Slot Opening
7	Power Supply
8	Power Supply Internal Fan
9	Power Supply LED Indicator

### REAR VIEW

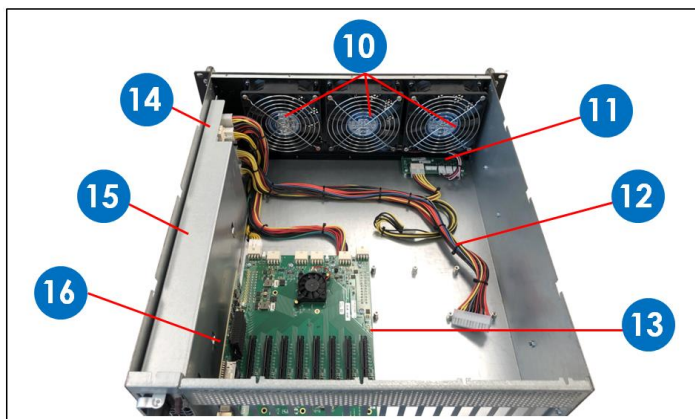

Item#	Description
10	3 Fans
11	LED / Fan Power Board
12	ATX Power Cables
13	OSS-457 Backplane
14	Power Supply Board Module
15	Power Supply (Housing)
16	Target Card

### TOP VIEW

## 1.7 Pre-Installation Information

Before using the One Stop Systems expansion chassis, you should perform the following steps:

- Inventory the shipping carton contents for all of the required parts
- Gather all of the necessary tools required for installation
- Read this manual

## 1.8 Tools Required for Installation

To complete the installation of the product you will need a Phillips-head screwdriver and ESD wrist strap to prevent electrostatic discharge.



## 1.9 Items List

Item	Qty	Description
1	1	Full-height PCI Express host card
2	1	1 or 2 meter shielded x16 cable
3	2	U.S. Standard 125V or 250V
4	1 set	Rackslide and Kit



## 2 Hardware Set-up / Installation

The following steps will guide you through the installation of your One Stop Systems expansion system

**CAUTION**

Hardware installation shall be performed only by qualified service personnel per UL and IEC 60950-1.

**Electrostatic Discharge (ESD) Warning**

All PCI cards are susceptible to electrostatic discharge. When moving PCI cards, it is best to carry the cards in anti-static packaging. If you need to set a PCIe card down, be sure to place it inside or on top of an anti-static surface. For more information, see "Protecting Against Electrostatic Discharge" in the Preface.

**WARNING**

High voltages are present inside the expansion chassis when the unit's power cord is plugged into an electrical outlet. Disconnect the power cord from the AC outlet before removing the enclosure cover. Turning the system power off at the power on/off switch does not remove power to components. High voltage is still present.

**CAUTION**

Before touching anything inside the enclosure, move to an ESD station and follow proper ESD procedures. Failure to do so may result in electrostatic discharge, damaging the computer or its components. For more information, see "Protecting Against Electrostatic Discharge" in the Preface.

---

## 2.1 Installation-Procedures Overview

Below is the concise version on how to set up the 4u Value 8 slot expansion unit.

1. Open Enclosure
2. Install Target Interface card(s) (If not installed)
3. Install Host Interface card(s) into host computer
4. Connect link cable
5. Attach Power Cords
6. Connect to Electrical Outlet
7. Power-ON (power-up) computer and expansion unit
8. Hardware Check
9. Re-install Top Cover
10. Verify Installation (via Operating System)
11. PCIe cards Installation



### NOTE

It is highly recommended to install any 3<sup>rd</sup> party PCI-E cards / High Power PCIe cards after you have verified and tested the OSS expansion unit is working OK .

When installing 3<sup>rd</sup> Party PCIe card, start with one card first to determine if there are any software and hardware issues or incompatibility problems that may occur. This will help you in troubleshooting the problem more easily and efficiently. If everything works well and no configuration issues, you can proceed with the installation of the remaining 3<sup>rd</sup> party PCIe cards.

**Always refer to or read “3<sup>rd</sup> party manufacturer installation guide” for further instructions.**

## 2.2 Before you Begin

The system's power supply is auto-switching, it will automatically switch to match whatever source power you are using. Since all products ship with a US/Canadian Standard, 125V or 250V power cord.

## 2.3 Remove Top Cover

Remove the five (5) mounting screws on top of the chassis. Slide the enclosure cover towards the front of the unit to disengage it from the guides until it clears the back hold-down, and then lift the cover off.

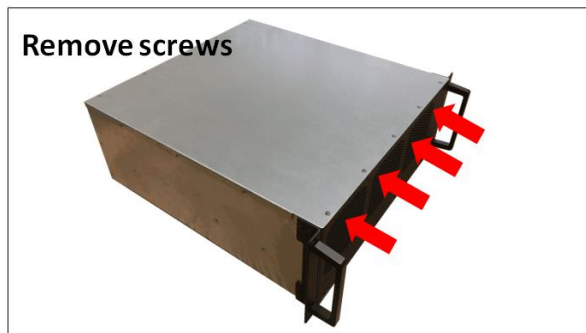



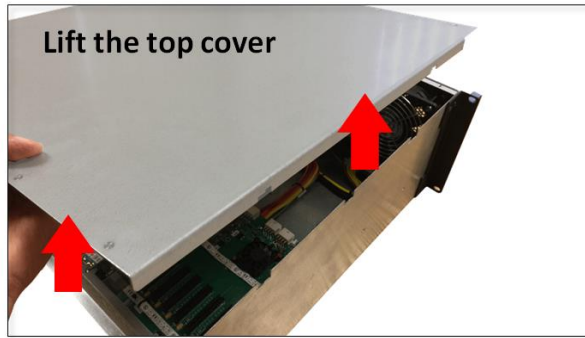

Check inside the unit; make sure both "Target Cards" are fully seated in their designated slot.

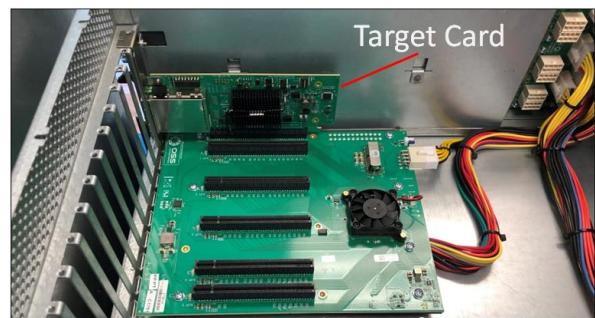
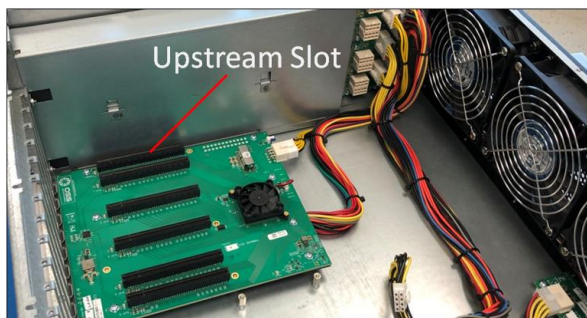

## 2.4 Install Target Card



**NOTE**

It is highly recommended to use the Gen3 HIB38-x16 (OSS-PCIe-HIB38-x16-H) to avoid performance and link up issues between host and expansion unit.

By default the "Target card (OSS-PCIe-HIB38-x16-T) " or "Expansion Interface card" is installed in the target slot of the expansion system

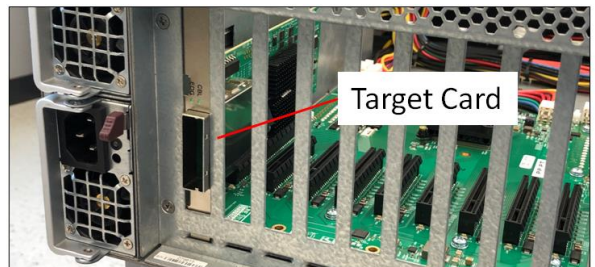
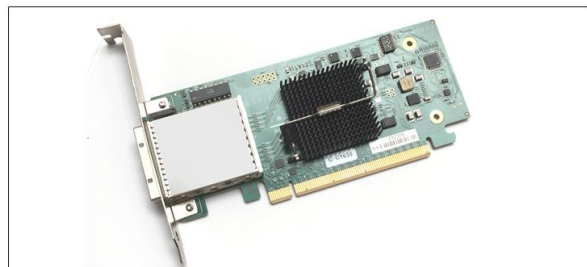

If the Target card missing, install the target card in the Upstream Slot on the backplane. Prior to installing the "Target card", verify the Dipswitch SW1 is set to proper settings, see pictures below.

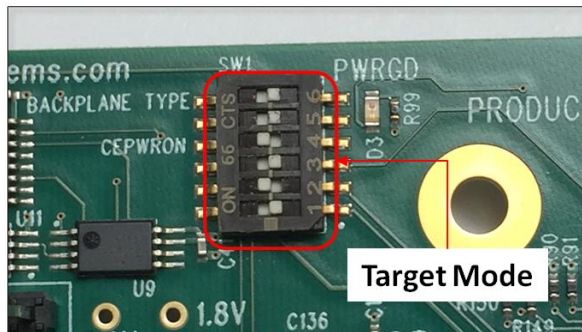
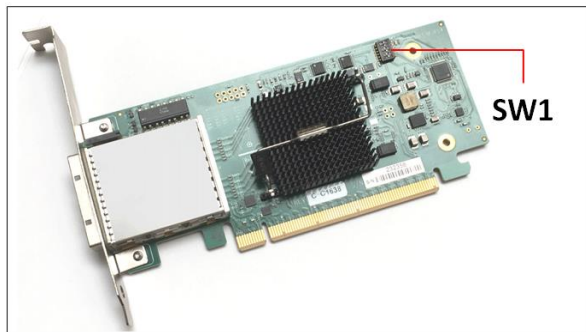

Photo below shows the target card is installed in the "Upstream" slot.



Make sure the Target card is seated in the slot properly and secured.

## 2.5 Install Host Interface Cards



### NOTE

It is highly recommended to use the Gen3 HIB38-x16 (OSS-PCIe-HIB38-x16-H) to avoid performance and link up issues between host and expansion unit.

Install the Host Interface card. Begin the installation by first powering down your computer. Remove the power cord. 5VSB (5V Standby) is still available, if the power cord is still installed. Use the procedures for shutting down your operating system and shutting off power to your computer provided in your owner's manual or system documentation. The PCIe host card is a "half-height," x16-capable PCIe card mounted to "full-height" bracket as shown below.

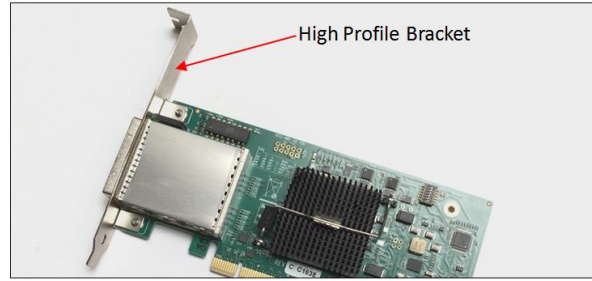
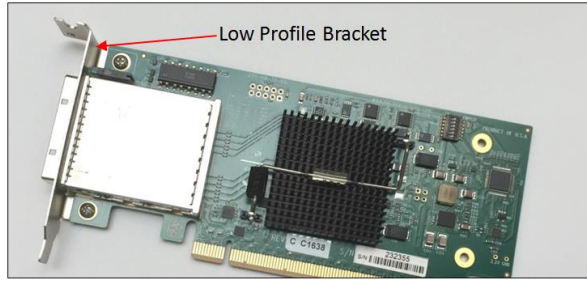

For low profile case applications, change the mounting bracket to the low profile bracket. You can order a low profile bracket by contacting our Sales Support. Replacing the “High Profile Bracket” with “Low Profile Bracket” is done by removing the screws that hold the card to the bracket. Detach the standard bracket from the card, and place the low profile bracket and secure it. Use proper ESD procedures when completing this action.

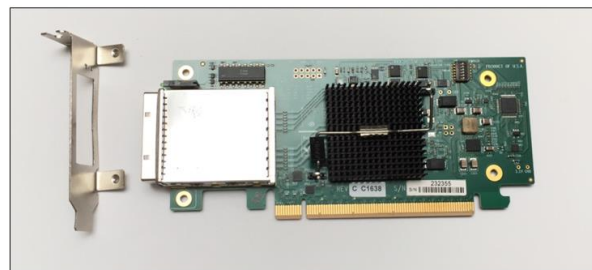

Before installing the Host Interface card into PCIe slot, check the SW1 Dip switch is set to Host Mode, see picture below for correct settings.

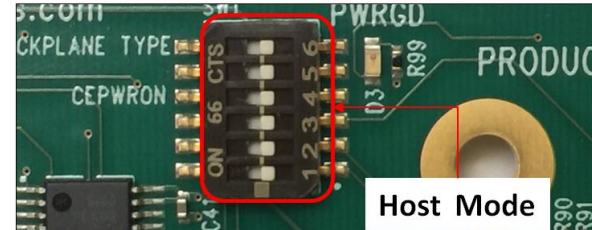

If Dipswitches are set correctly, insert the host card into a vacant x16 PCIe slot by gently pushing the card until it is firmly seated then secure the card to the slot with a mounting screw, see next photos.

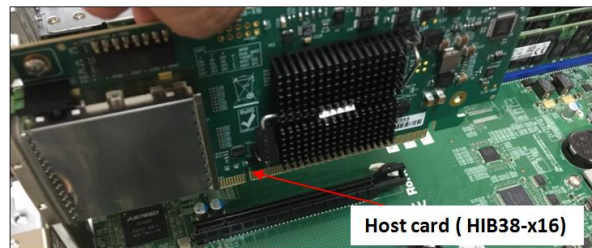
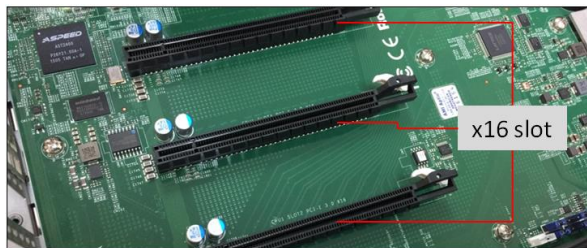

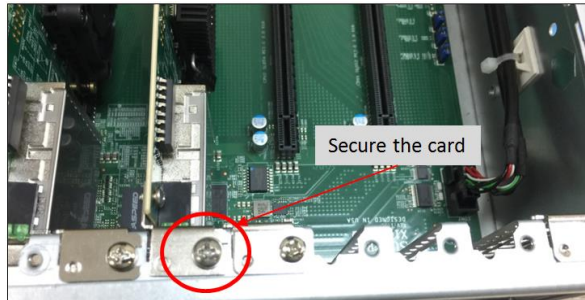
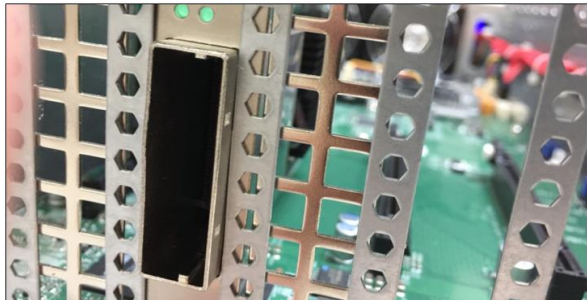

### 2.5.1 Installation of host card in a server using a “Riser Card”

This section describes on how to install the Host Card via “riser card” in the host computer.

- Remove the riser card from the computer (see computer manufacturing instructions on how to dismount the riser card).
- Place the riser card on a sturdy / solid surface.
- Plug in the host card ( see photos below).
- Reinstall the rise card back into the computer-mounting bracket / PCIe slot.

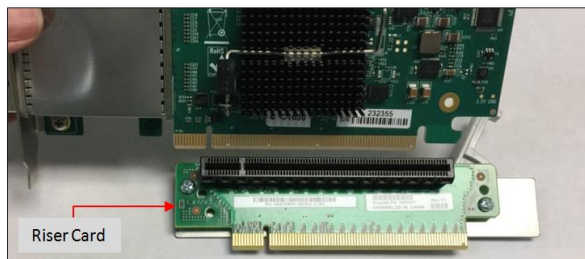
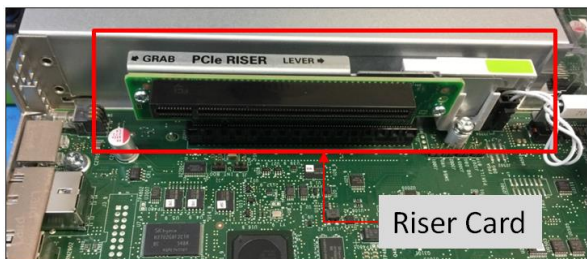

#### STOP

YOU MUST ONLY INSTALL THE PCIe HOST CARD INTO A PCI EXPRESS SLOT.

**Only use cards WITH brackets.** This will ensure that your PCIe host card can only be inserted into a PCIe slot. Although PCI Express cards without brackets may fit into conventional PCI slots, you run the risk of damaging the PCI Express host card if you insert it into a PCI slot. Please ensure that your host computer has PCI Express slots and install the host card only into a PCI Express slot.

## 2.6 Connect Link Cable

A 1 or 2-meter long cable is included with your One Stop Systems expansion chassis, features a x16 connector on each side. Connect the cable to the Target and Host Interface cards. For proper way of connecting the cable to the interface card, see pictures below.

Push the “Latch Metal Tab” on the cable while slowly inserting it into the cable-port of the interface card.

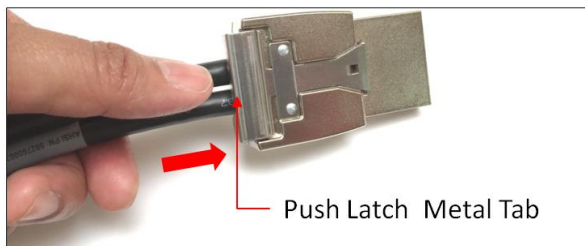

Carefully position the expansion chassis so that the supplied cable will conveniently reach from the host computer to the connectors on the back of the chassis. Then connect the cable to the host card in the host computer.

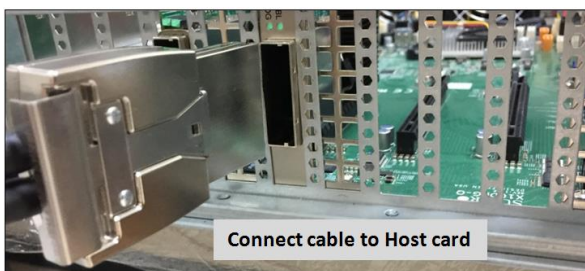

Connect the other one end of the cable to the target card in the expansion chassis.

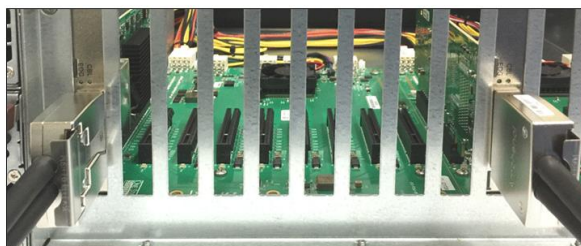

Make sure the cables are fully secured, check the metal tab is fully latched onto holes of the card, see photos below. This will prevent the cable from being dislodged or disconnected from the card.

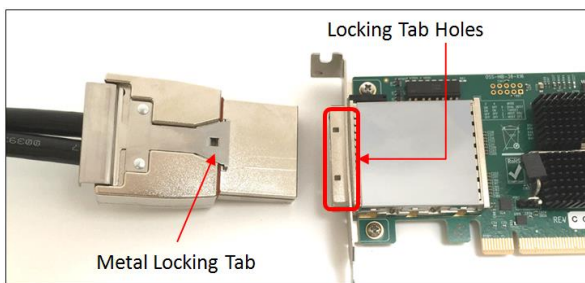

### 3 Applying Power Correctly

#### 3.1 Connect Power Cord / Cable

Use the power cord supplied with the unit, connect the power cord to the back of the power supply. Ensure that the system's power supply unit is fully secured before connecting the power cord. You should have either the 125v or the 250v power cord. If you only have the 125V power cord and you require the 250V please contact our Sales Team ([sales@onestopsystems.com](mailto:sales@onestopsystems.com)) to place an order.

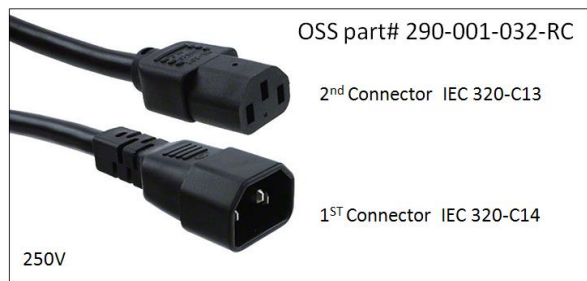

Power Cord Voltage Table

Power Cord	PSU Watt	Voltage	AMPS	Hz
125V	1000W	100-127V	12-9.5A	50-60Hz
250V	1800W	200-220V	10-9.5A	50-60Hz
250V	1980W	220-230v	10-9.8A	50-60Hz
250V	2000W	230-240V	10-9.8A	50-60Hz

NOTE: When using 115-125V power cord you are limited to 1000W of power.

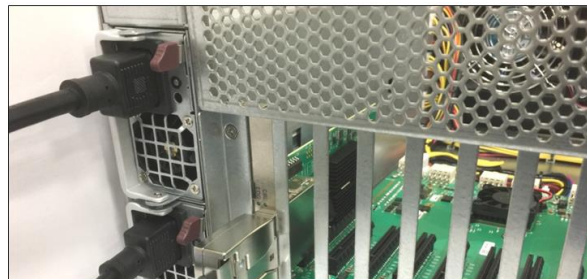

#### 3.2 Connect power cord to electrical outlet.

It is highly recommended using a power surge. This product is provided with a power supply that **automatically adjusts to input voltages between 100 to 240 Vac**. A U.S. and Canadian 125V or 250V power supply cord is provided with this product. If you are using a 250V power cord, you would need to connect that to a PDU (power distribution unit). You can buy the PDU on any online electronic stores. OSS does not sell the PDU.

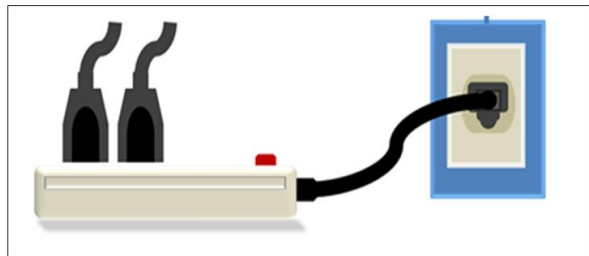

### 3.3 Power ON the Host Computer

Before powering ON the computer, make sure the Host Interface cards are seated correctly in the PCIe slot and the cables are firmly connected. Upon powering ON the computer, the expansion unit will power UP automatically. The power supply LED will come up solid green, see photos below. If Power LED indicator is showing “Amber” in color, it indicates fault or power issue.

Green Led: PSU Good



Amber LED: PSU fault or power issue



### 3.4 Power ON the Expansion Unit

The expansion unit will power UP automatically upon turning ON the host computer. The two front LEDs will come ON as “solid-green”.



The LED indicator on the power supply module will come up “solid green” as soon as the unit is powered UP. Each power supply module has its own “Power LED Indicator”, you should see both Power LEDs lit.

## 4 Hardware Check

Once the host computer has booted up, check the expansion unit and verify that all LEDs are correctly illuminated. An operational expansion chassis will show the following LEDs on the backplane, Interface cards, the back and front of the unit. The rear of the expansion unit will show two green solid green LEDs on both power supplies and two solid green LEDs on each target card.

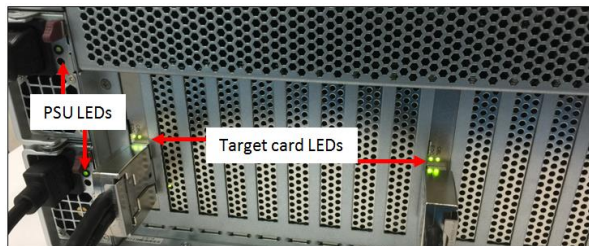

1. LinkUP LED: Target card and Host card, CBL and EDG LEDs both should be illuminated as solid green.
2. 2. Target Slot LED "D1" should be ON as solid green.
3. 2. Front LEDs: PWR and FAN should be illuminated solid green.
4. 3. Power Supply LED Indicator: should be ON as solid green.

### 4.1 LinkUP LED (CBL & EDG)

The LED indicators (CBL & EDG) on both Target and Host cards will come up as solid green. This is an indication that a LINK between host and chassis has been established. The Linkup LEDs represent only an initial connection/handshake between the chassis and host computer. A successful linkup does not represent transfer or exchange of data.

1. The CBL LED shows the link status between the host card in the host computer and the target card in the expansion chassis.
2. The EDG / EDGE shows:
  - a. HOST card – connection between host card and host system
  - b. TARGET card – connection between the switch on the target card and the switch in the expansion chassis.



### 4.2 Target Slot & PWRGO LEDs

The "Target Slot LED" is located on the bottom part of PCIe slot. This LED (D1) should be ON as solid green. This represents that Link is up at Gen 3 speed. The PWRGO LED, signifies that the card is powered UP correctly.

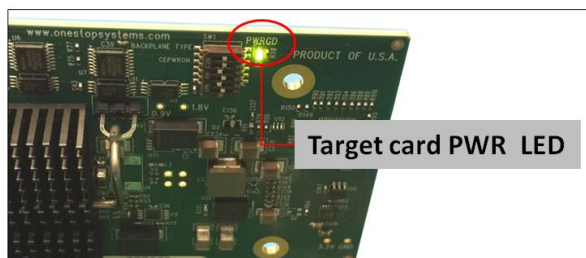
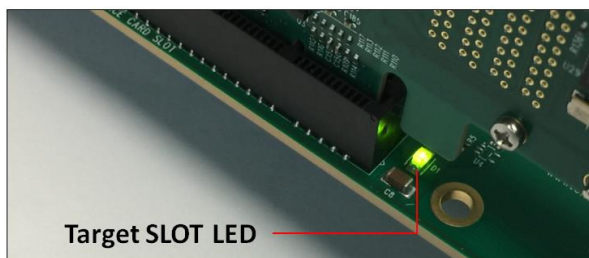



## 4.3 Re-install Top Cover



### CAUTION

Re-install top cover when done checking internal LEDs to allow proper airflow



## 4.4 Front LEDs Status Indicator

There are two LED status indicators located on the front of the unit. These two LEDs should be ON as solid green upon powering UP the expansion unit.

1. **PWR LED:**
  - a. Solid Green: Power good
  - b. Amber / Orange: Faulty
2. **FAN LED:**
  - a. Solid Green: Operational
  - b. Red: Fan is faulty.

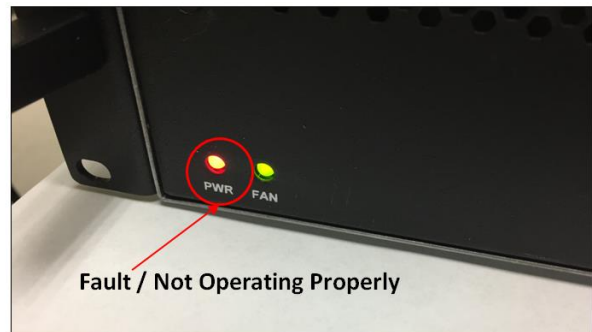
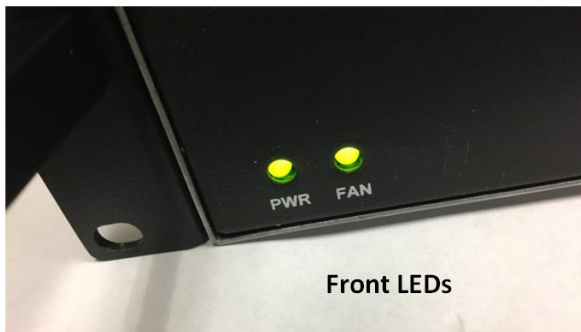

## 4.5 Power Supply LED Indicator

Both LEDs should be ON as solid green, it indicates the OK status of the DC GOOD signal. The LED shall continue to glow under normal operation of the power supply. If this LED is blinking or not lit or in amber color, the power supply is not operating properly.

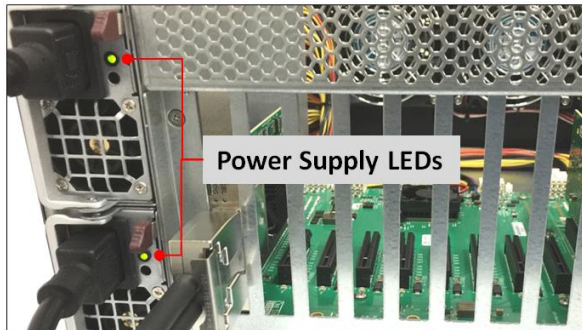

- During protection mode ( main 12V rail), the LED should be amber.
- During protection mode ( 5Vsb rail), the LED should be off.
- When protection is cleared, the LED should go back to the original intended status.
- When the unit is in standby with AC is present, the LED should be amber.
- When the unit is in standby with no AC is present, the LED should be off.
- When the unit is turned on properly, the LED is green.
- During wakeup redundancy mode, the LED should be Green.
- During wakeup redundancy sleep mode, the LED should be blinking Green in 1Hz

## 5 Software Installation

### 5.1 Software Driver Installation

One Stop Systems 4U Value expansion unit requires no driver on Windows 7, Windows 8, Windows 10, Windows Server, Linux, Unix, Centos and Mac OS, which means no installation of One Stop Systems driver.

Before attempting to install anything on a Windows system, you should ensure that you have set a Restore Point, that all data files are closed and that you have a current backup of your data.

### 5.2 Verify Systems Installation

#### 5.2.1 How to verify system on Windows OS (Windows Server)

Verify hardware device in Windows Operating System. As your Windows computer starts up, you will see a small message box pop-up in the lower-right corner of the screen to alert you that Windows has found new hardware.

To verify a successful installation on Windows, find the **'My Computer'** icon and "right-click" on it. Then select **'Manage'** from the pop-up menu. Next, click on **'Device Manager'** in the leftmost Computer Management window. Finally, click on the **View Menu** and select **View Devices by Connection**.

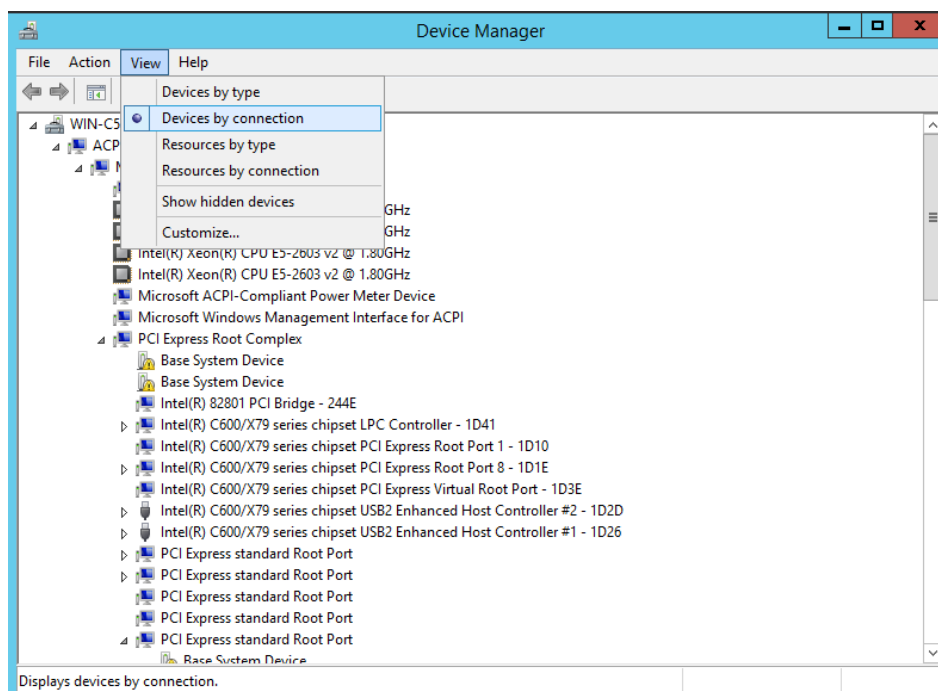

Open ACPI (BIOS) → Open PCI Bus → Click the '+' sign several times until you reach a PCI Express Root Port Complex with PCI Express standard Upstream Switch Port and PCI Express standard Downstream Switch Port.

When installed properly, you will see ten PCI Express standard Downstream Switch Ports below the PCI Express standard Upstream Switch Ports. The screenshot below represent the structure of one expansion board attached to a specific host computer. It is either the 1<sup>st</sup> or 2<sup>nd</sup> backplane is attached to a specific host computer.

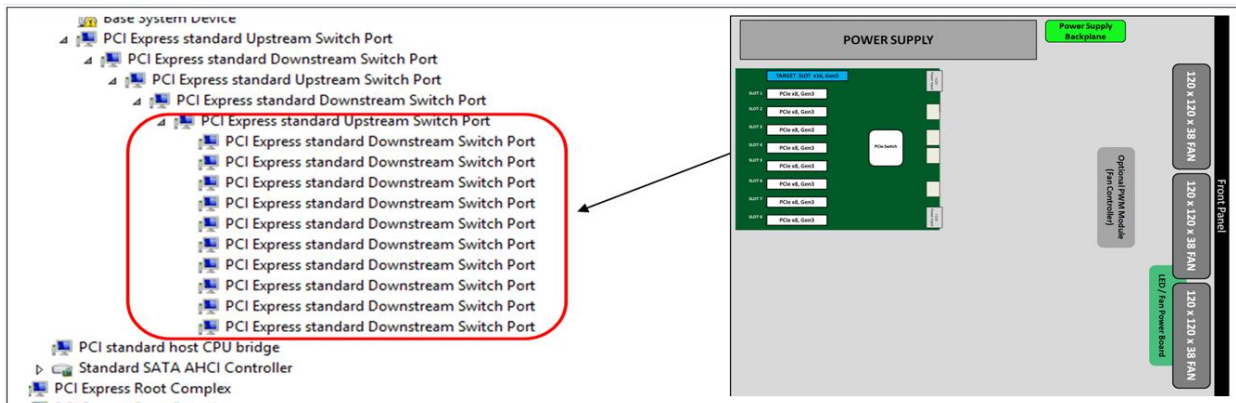

OR

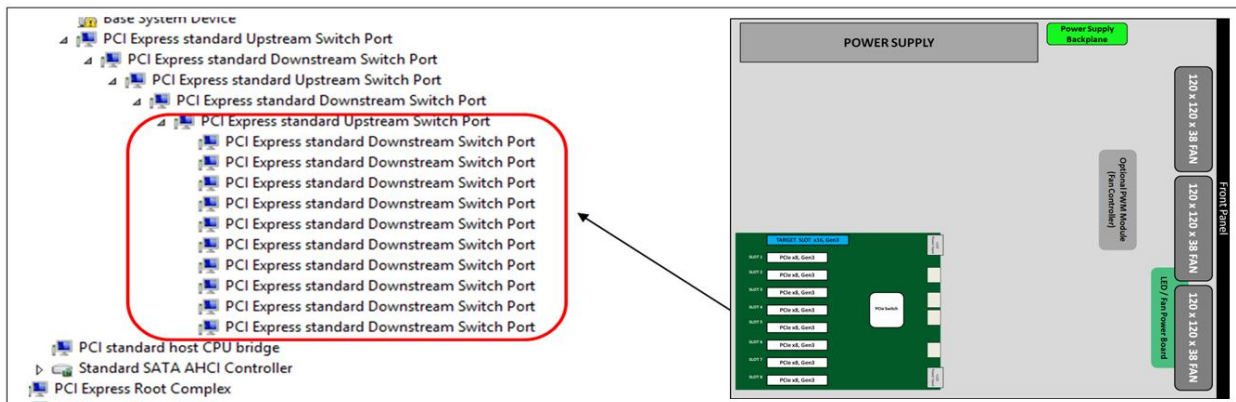

If the verification is successful, you may now proceed to installing your 3<sup>rd</sup> Party PCIe Cards.

NOTE: If you are not seeing ten PCI Express standard Downstream Switch Ports (as shown from the above photos) in Windows Device Manager, it means the host computer is not recognizing or detecting the board. You may be having “faulty host card or target card” and “or may be having an intermittent backplane failure. For troubleshooting, try the following :

- Verify 2x PCIe x16 cables is firmly connected on both ends
- Verify Host/Target cards are firmly seated in both Host and 4UV Chassis
- Verify power is being properly applied to both Host and 4UV Chassis
- Verify LEDs are illuminated properly on 4UV Chassis
- Verify Dipswitch settings on Host/Target cards
- If the issue is not resolved, contact OSS customer support

The next screenshot below represents two expansion boards that are attached to one host computer; two host interface cards plugged into the host computer motherboard (via PCIe slot) . Window Device manager will show two instances of 10 PCI Express standard Downstream Switch Ports.

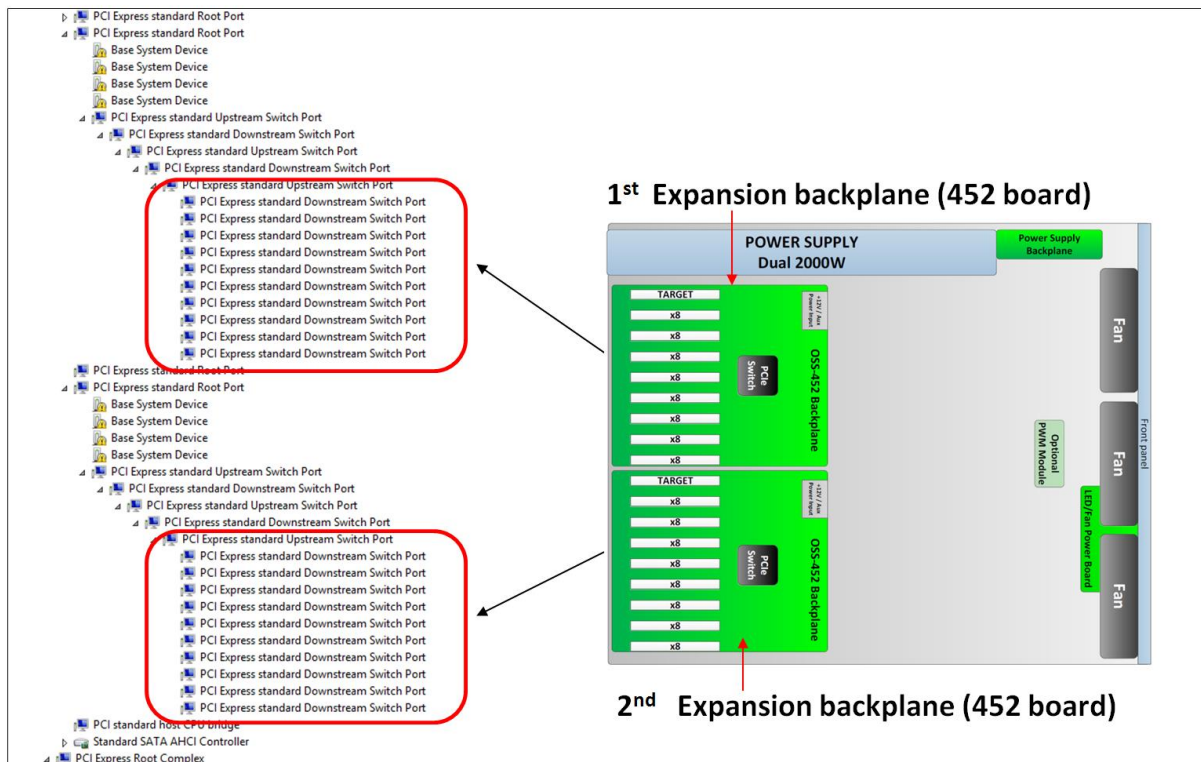

### 5.2.3 PCIe slot and Device ID assignment

On Windows Device Manager each PCIe slot on the backplane has a designated Device ID number (i.e. Device 0), see photo below. These PCIe slots on the 452 expansion backplane and are labeled with silk-screen from P1 to P8. P1 is the first slot and P8 is the last slot on the board.

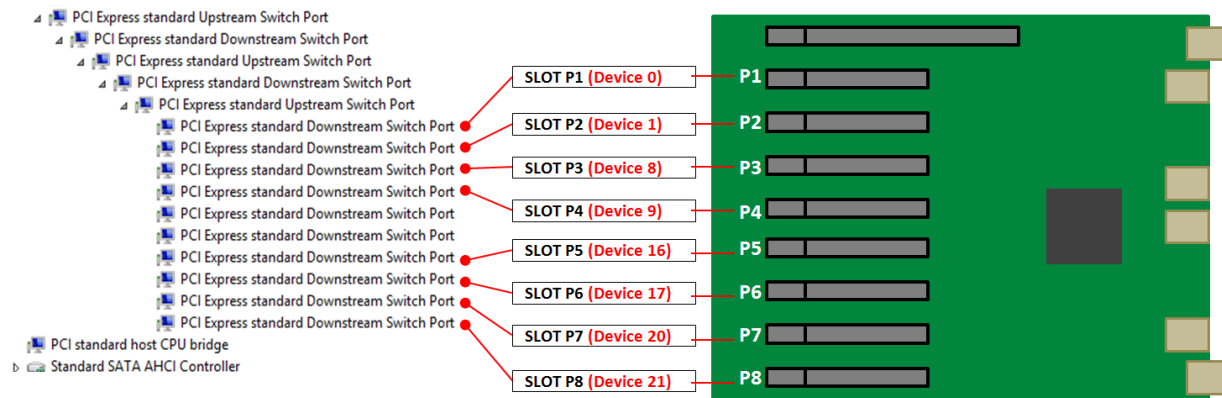

See above photo, Windows Device Manager is showing “10 PCI Express standard Downstream Switch Ports”, only 8 ports are allocated, the remaining two ports are unassigned, this is normal.

The following eight photos are screenshots of Windows Device manager showing the assigned slot number and device number per PCI Express standard Downstream Switch Port. You can use this as your reference point on finding which card is plugged into a specific a slot on the expansion backplane.

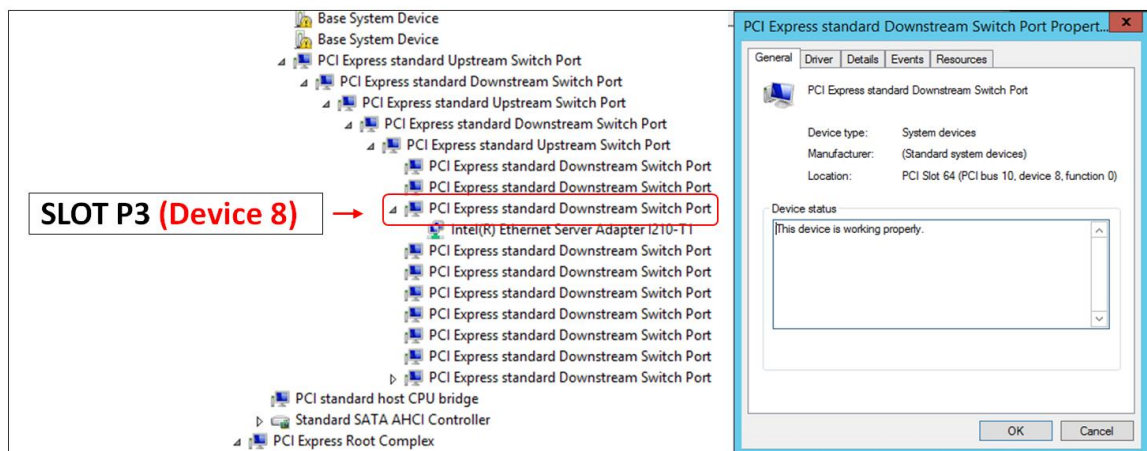
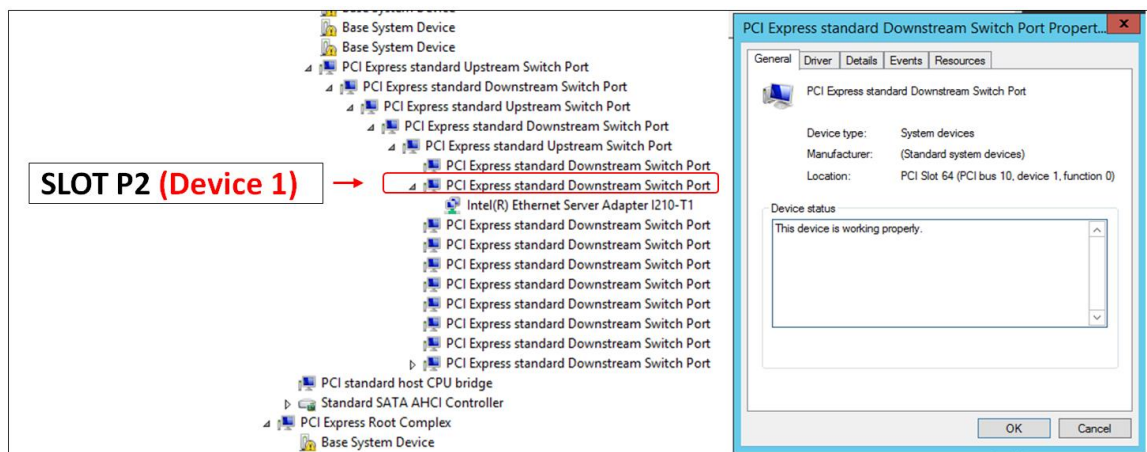
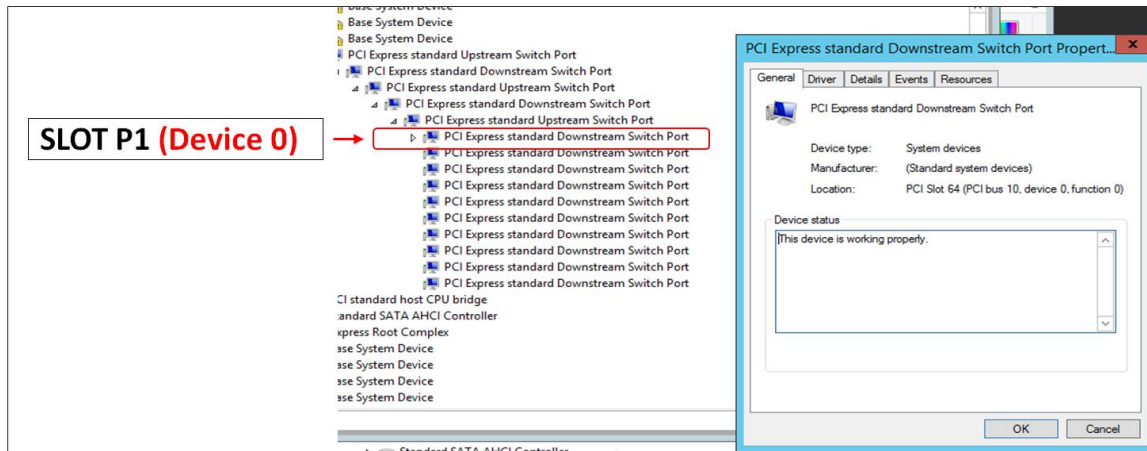

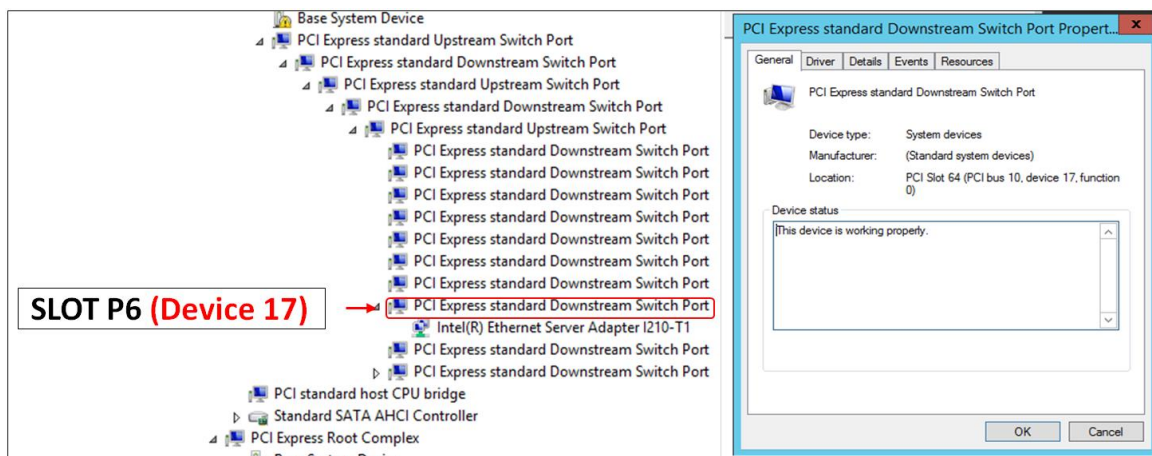
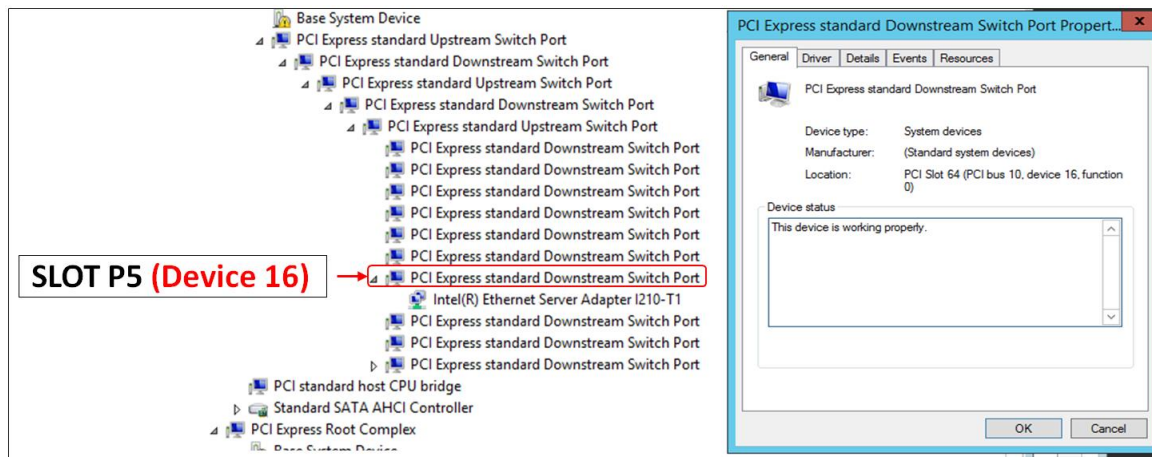
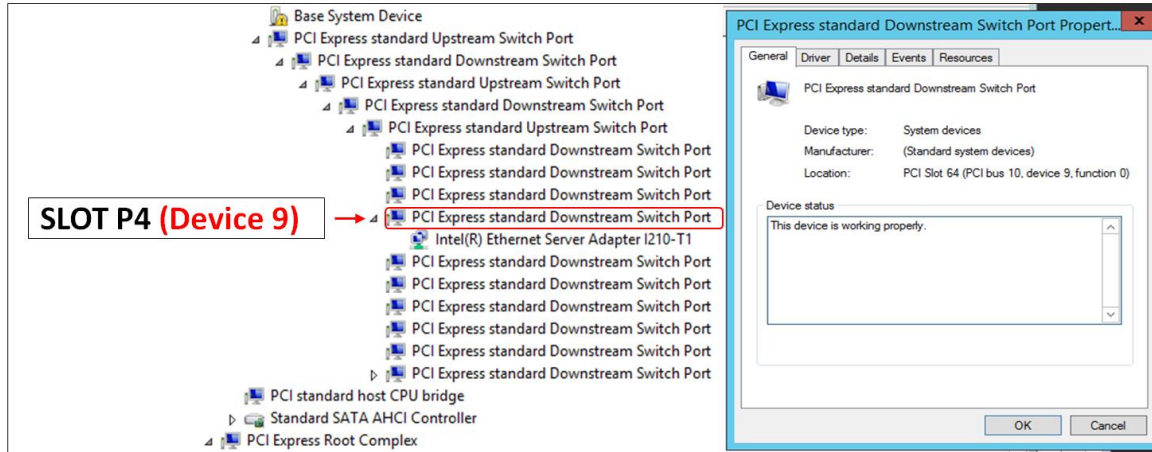

The screenshot shows the Windows Device Manager tree on the left, expanded to 'Base System Device' > 'PCI Express standard Downstream Switch Port' > 'PCI Express standard Downstream Switch Port'. A red box highlights the selected device, and a red arrow points to a text box labeled 'SLOT P7 (Device 20)'. To the right, the 'PCI Express standard Downstream Switch Port Properties' dialog box is open, showing the 'General' tab with the following information: Device type: System devices; Manufacturer: (Standard system devices); Location: PCI Slot 64 (PCI bus 10, device 20, function 0); Device status: This device is working properly. The 'OK' and 'Cancel' buttons are visible at the bottom.

The screenshot shows the Windows Device Manager tree on the left, expanded to 'Base System Device' > 'PCI Express standard Downstream Switch Port' > 'PCI Express standard Downstream Switch Port'. A red box highlights the selected device, and a red arrow points to a text box labeled 'SLOT P8 (Device 21)'. To the right, the 'PCI Express standard Downstream Switch Port Properties' dialog box is open, showing the 'General' tab with the following information: Device type: System devices; Manufacturer: (Standard system devices); Location: PCI Slot 64 (PCI bus 10, device 21, function 0); Device status: This device is working properly. The 'OK' and 'Cancel' buttons are visible at the bottom.



## 5.2.4 How to verify Expansion device in Linux OS

On a Linux based system, the installation can be verified by typing the following command lines:

- **lspci -t** Displays the overall structure of the PCIe expansion system
- **lspci -vv** Lists additional information about the PCIe switch (in our case it will list the Integrated Device Technology (IDT) information.
- **lspci -vvv** Displays the most comprehensive information about the expansion system.

Typical output from `lspci -vvv` is verbose, but you can dig through the information to find very important information. There are so many registers and settings associated with PCI Express Switches.

Use the "`lspci | grep 8796`" command to check that the One Stop Systems card and slot devices are detected (see image below). Broadcom PLX is the PCIe switch (component) on the One Stop Systems expansion board.

```
[root@sca05-0a81fd86 Documents]# lspci | grep 8796
17:00.0 PCI bridge: PLX Technology, Inc. Device 8796 (rev ab)
18:00.0 PCI bridge: PLX Technology, Inc. Device 8796 (rev ab)
18:01.0 PCI bridge: PLX Technology, Inc. Device 8796 (rev ab)
18:08.0 PCI bridge: PLX Technology, Inc. Device 8796 (rev ab)
18:09.0 PCI bridge: PLX Technology, Inc. Device 8796 (rev ab)
18:0c.0 PCI bridge: PLX Technology, Inc. Device 8796 (rev ab)
18:0d.0 PCI bridge: PLX Technology, Inc. Device 8796 (rev ab)
18:10.0 PCI bridge: PLX Technology, Inc. Device 8796 (rev ab)
18:11.0 PCI bridge: PLX Technology, Inc. Device 8796 (rev ab)
18:14.0 PCI bridge: PLX Technology, Inc. Device 8796 (rev ab)
18:15.0 PCI bridge: PLX Technology, Inc. Device 8796 (rev ab)
[root@sca05-0a81fd86 Documents]#
```

The first PCI Bridge in this example is the Upstream Port.

```
[root@sca05-0a81fd86 Documents]# lspci | grep 8796
17:00.0 PCI bridge: PLX Technology, Inc. Device 8796 (rev ab)
18:00.0 PCI bridge: PLX Technology, Inc. Device 8796 (rev ab)
18:01.0 PCI bridge: PLX Technology, Inc. Device 8796 (rev ab)
18:08.0 PCI bridge: PLX Technology, Inc. Device 8796 (rev ab)
18:09.0 PCI bridge: PLX Technology, Inc. Device 8796 (rev ab)
18:0c.0 PCI bridge: PLX Technology, Inc. Device 8796 (rev ab)
18:0d.0 PCI bridge: PLX Technology, Inc. Device 8796 (rev ab)
18:10.0 PCI bridge: PLX Technology, Inc. Device 8796 (rev ab)
18:11.0 PCI bridge: PLX Technology, Inc. Device 8796 (rev ab)
18:14.0 PCI bridge: PLX Technology, Inc. Device 8796 (rev ab)
18:15.0 PCI bridge: PLX Technology, Inc. Device 8796 (rev ab)
[root@sca05-0a81fd86 Documents]#
```

Upstream Port

The 'Downstream' ports are the remaining are the PCIe slots.

```
[root@sca05-0a81fd86 Documents]# lspci | grep 8796
17:00.0 PCI bridge: PLX Technology, Inc. Device 8796 (rev ab)
18:00.0 PCI bridge: PLX Technology, Inc. Device 8796 (rev ab)
18:01.0 PCI bridge: PLX Technology, Inc. Device 8796 (rev ab)
18:08.0 PCI bridge: PLX Technology, Inc. Device 8796 (rev ab)
18:09.0 PCI bridge: PLX Technology, Inc. Device 8796 (rev ab)
18:0c.0 PCI bridge: PLX Technology, Inc. Device 8796 (rev ab)
18:0d.0 PCI bridge: PLX Technology, Inc. Device 8796 (rev ab)
18:10.0 PCI bridge: PLX Technology, Inc. Device 8796 (rev ab)
18:11.0 PCI bridge: PLX Technology, Inc. Device 8796 (rev ab)
18:14.0 PCI bridge: PLX Technology, Inc. Device 8796 (rev ab)
18:15.0 PCI bridge: PLX Technology, Inc. Device 8796 (rev ab)
[root@sca05-0a81fd86 Documents]#
```

Downstream Port

### 5.2.5 PCIe slot and Port# assignment

On Linux-based OS each PCIe slot on the backplane has a designated Port number (i.e. Port 0), see photo below. On Windows OS, it is called Device ID, on Linux OS it is Port#. There are 8 available PCIe slots on the 452 expansion backplane and are labeled with silk-screen from P1 to P8.

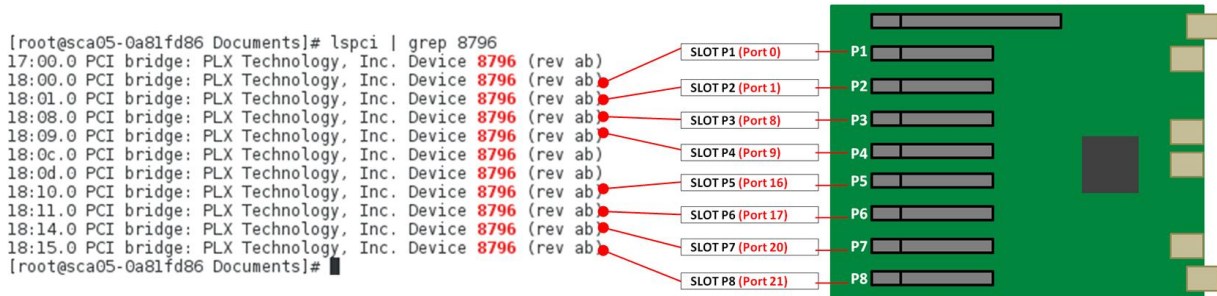

As shown from the photo above, the “lspci | grep 8796” output is showing “10 PCI Bridge devices”, only 8 ports are allocated, the remaining two ports are unassigned. This is normal.

Each line on the output above shows a PCI device. Each device is given a bus number (i.e. 17:00.0), a device number and a function number. Since the PCI specification permits a system to host up to 256 buses, nonzero domain numbers are only used to group PCI buses in very large systems. Each bus can host up to 32 devices, and a PCI device can have up to eight functions. In more technical terms, a device's location is specified by a 16-bit domain number, an 8-bit bus number, a 5-bit device number and a 3-bit function number; the last three numbers are commonly referred to as the **device's BDF or B/D/F (for bus/device/function)**.

See table below, the Bus#/Device#/Function# will vary depending on the computer and Linux operating systems. The Slot# and Port# are fixed, this will not change regardless of what Linux operating system the computer is running on.

Bus#/Device#/Function#	Upstream / Downstream Port	Slot#	Port#
17:00.0	Upstream Port	Target Slot	Port# 4
18:00.0	Downstream Port	Slot 1	Port 0
18:01.0	Downstream Port	Slot 2	Port 1
18:08.0	Downstream Port	Slot 3	Port 8
18:09.0	Downstream Port	Slot 4	Port 9
18:0c.0	Not Being Used	Not Being Used	Not Being Used
18:0d.0	Not Being Used	Not Being Used	Not Being Used
18:10.0	Downstream Port	Slot 5	Port 16
18:11.0	Downstream Port	Slot 6	Port 17
18:14.0	Downstream Port	Slot 7	Port 20
18:15.0	Downstream Port	Slot 8	Port 21

## 5.2.6 Linux Commands to check on expansion device

- To check on One Stop Systems device, type `lspci | grep 8796`.
- To check or to identify whether the bus is the Upstream port and Downstream port, on the terminal window type `lspci -s XX.XX.X -vvv | grep 'Capabilities'`. Replace x with the bus number for example 17:00.0
- To check Upstream port speed and bandwidth, type `lspci -s XX.XX.X -vvv | grep 'LnkCap'`
- To check the speed and linkwidth, type `lspci -s 01:00.0 -vvv | grep 'LnkSta'`
- To check for the slot# and port# of the Downstream port, type `lspci -s XX:XX.X -vvv | grep 'Slot\|port'`.

To check the port number, slot number, bandwidth, speed and whether it is Upstream or Downstream port, type the command on the terminal `lspci -s 18:15.0 -vvv | grep 'Slot\|Port'`, see output below.

```
[root@sca05-0a81fd86 ~]# lspci -s 18:15.0 -vvv | grep 'Slot\|Port'
Capabilities: [68] Express (v2) Downstream Port (Slot+), MSI 00
LnkCap: Port #21, Speed 8GT/s, Width x8, ASPM L1, Exit Latency L0s <4us, L1 <4us
LnkSta: Speed 2.5GT/s, Width x1, TrErr- Train- SlotClk- DLActive+ BWMgmt+ ABWMgmt-
Slot #21, PowerLimit 25.000W; Interlock- NoCompl-
VC0: Caps: PATOffset=00 MaxTimeSlots=1 RejSnoopTrans-
```

To check for speed only, type `lspci -s 18:15.0 -vvv | grep 'LnkSta'`

```
[root@sca05-0a81fd86 ~]# lspci -s 18:15.0 -vvv | grep 'LnkSta'
LnkSta: Speed 2.5GT/s, Width x1, TrErr- Train- SlotClk- DLActive+ BWMgmt+ ABWMgmt-
LnkSta2: Current De-emphasis Level: -3.5dB, EqualizationComplete-, EqualizationPhase1-
```

To check for port number, type `lspci -s 18:15.0 -vvv | grep 'LnkCap'`

```
[root@sca05-0a81fd86 ~]# lspci -s 18:15.0 -vvv | grep 'LnkCap'
LnkCap: Port #21, Speed 8GT/s, Width x8, ASPM L1, Exit Latency L0s <4us, L1 <4us
```

To check the details of the BUS and downstream port, use command “lspci -s xx:xx.x” -vvv, just replace the X with the B/D/F (Bus#,Device#,Function#). For example, we will use bus 18:15.0, simply type the command **lspci -s 18:15.0 -vvv**, see output below.

18 is bus number, 15 is device number and 0 is function number

```

18:15.0 PCI bridge: FLX Technology, Inc. Device 8796 (rev ab) (prog-if 00 [Normal decode])
Control: I/O+ Mem+ BusMaster+ SpecCycle- MemWINV- VGASnoop- ParErr+ Stepping- SERR+ FastB2B- DisINTx+
Status: Cap+ 66MHz- UDF- FastB2B- ParErr- DEVSEL=fast >TAbort- <TAbort- <MAbort- >SERR- <PERR- INTx-
Latency: 0, Cache Line Size: 64 bytes
Bus: primary=18, secondary=22, subordinate=22, sec-latency=0
I/O behind bridge: 0000f000-00000fff
Memory behind bridge: c6900000-c6bfffff
Prefetchable memory behind bridge: 00000000fff00000-000000000000fffff
Secondary status: 66MHz- FastB2B- ParErr- DEVSEL=fast >TAbort- <TAbort- <MAbort- <SERR- <PERR-
BridgeCtl: Parity+ SERR+ NoISA- VGA- MAbort- >Reset- FastB2B-
PriDiscTmr- SecDiscTmr- DiscTmrStat- DiscTmrSERREn-
Capabilities: [40] Power Management version 3
Flags: PMEClk- DSI- D1- D2- AuxCurrent=0mA PME(D0+,D1-,D2-,D3hot+,D3cold+)
Status: D0 NoSoftRst+ PME-Enable- DSel=0 DScale=0 PME-
Capabilities: [48] MSI: Enable+ Count=1/8 Maskable+ 64bit+
Address: 00000000fee005d8 Data: 0000
Masking: 000000ff Pending: 00000000
Capabilities: [68] Express (v2) Downstream Port (Slot+), MSI 00
DevCap: MaxPayload 2048 bytes, PhantFunc 0
ExtTag- RBE+
DevCtl: Report errors: Correctable+ Non-Fatal+ Fatal+ Unsupported+
RlxdOrd- ExtTag- PhantFunc- AuxPwr- NoSnoop+
MaxPayload 256 bytes, MaxReadReq 128 bytes
DevSta: CorrErr- UncorrErr- FatalErr+ UnsuppReq+ AuxPwr- TransPnd-
LnkCap: Port #21, Speed 8GT/s, Width x8, ASPM L1, Exit Latency L0s <4us, L1 <4us
ClockPM- Surprise+ LLActRep+ BwNot+
LnkCtl: ASPM Disabled; Disabled- CommClk-
ExtSynch- ClockPM- AutWidDis- BWInt- AutBWInt-
LnkSta: Speed 2.5GT/s, Width x1, TrErr- Train- SlotClk- DLActive+ BWMgmt+ ABWMgmt-
SltCap: AttnBtn- PwrCtrl- MRL- AttnInd- PwrInd- HotPlug- Surprise-
Slot #21, PowerLimit 25.000W; Interlock- NoCompl-
SltCtl: Enable: AttnBtn- PwrFlt- MRL- PresDet- CmdCplt- HPIrq- LinkChg-
Control: AttnInd Unknown, PwrInd Unknown, Power- Interlock-
SltSta: Status: AttnBtn- PowerFlt- MRL- CmdCplt- PresDet+ Interlock-
Changed: MRL- PresDet- LinkState-
DevCap2: Completion Timeout: Not Supported, TimeoutDis-, LTR+, OBFF Via message ARIFwd+
DevCtl2: Completion Timeout: 50us to 50ms, TimeoutDis-, LTR-, OBFF Disabled ARIFwd-
LnkCtl2: Target Link Speed: 2.5GT/s, EnterCompliance- SpeedDis-, Selectable De-emphasis: -6dB
Transmit Margin: Normal Operating Range, EnterModifiedCompliance- ComplianceSOS-
Compliance De-emphasis: -6dB
LnkSta2: Current De-emphasis Level: -3.5dB, EqualizationComplete-, EqualizationPhase1-
EqualizationPhase2-, EqualizationPhase3-, LinkEqualizationRequest-
Capabilities: [a4] Subsystem: FLX Technology, Inc. Device 8796
Capabilities: [100 v1] Device Serial Number ab-87-00-10-b5-df-0e-00
Capabilities: [fb4 v1] Advanced Error Reporting
UESta: DLP- SDES- TLP- FCP- CmpltTO- CmpltAbrt- UnxCmplt- RxOF- MalfTLP- ECRC- UnsupReq+ ACSViol-
UEMsk: DLP- SDES- TLP- FCP- CmpltTO- CmpltAbrt- UnxCmplt- RxOF- MalfTLP- ECRC- UnsupReq+ ACSViol-
UESvrt: DLP+ SDES+ TLP- FCP+ CmpltTO- CmpltAbrt+ UnxCmplt- RxOF+ MalfTLP+ ECRC- UnsupReq+ ACSViol-
CESSta: RxErr- BadTLP- BadDLLP- Rollover- Timeout- NonFatalErr-
CEMsk: RxErr- BadTLP- BadDLLP- Rollover- Timeout- NonFatalErr+
AERCap: First Error Pointer: 1f, GenCap+ CGenEn- ChkCap+ ChkEn-
Capabilities: [138 v1] Power Budgeting <?>
Capabilities: [10c v1] #19
Capabilities: [148 v1] Virtual Channel
Caps: LPEVC=0 RefClk=100ns PATEntryBits=1
Arb: Fixed- WRR32- WRR64- WRR128-
Ctrl: ArbSelect=Fixed
Status: InProgress-
VC0: Caps: PATOffset=00 MaxTimeSlots=1 RejSnoopTrans-
Arb: Fixed+ WRR32- WRR64- WRR128- TWRR128- WRR256-
Ctrl: Enable+ ID=0 ArbSelect=Fixed TC/VC=01
Status: NegoPending- InProgress-

```

To check the details of the Upstream Port on 17:00.0, type `lspci -s 17:00.0 -vvv` command on the terminal window. The Bus number (17:00.0) will change depending on the host computer and location of host card. Below is the output of `lspci -s 17:00.0 -vvv`, there are several important information you need to check and these are the **Link speed, port#, slot# and Bandwidth**. There are commands to use to extract this information, go to "[Linux Commands.....](#)"

```
17:00.0 PCI bridge: PLX Technology, Inc. Device 8796 (rev ab) (prog-if 00 [Normal decode])
Physical Slot: 64
Control: I/O+ Mem+ BusMaster+ SpecCycle- MemWINV- VGASnoop- ParErr+ Stepping- SERR+ FastB2B- DisINTx+
Status: Cap+ 66MHz- UDF- FastB2B- ParErr- DEVSEL=fast >TAbort- <TAbort- <MAbort- >SERR- <PERR- INTx-
Latency: 0, Cache Line Size: 64 bytes
Region 0: Memory at c6c00000 (32-bit, non-prefetchable) [size=256K]
Bus: primary=17, secondary=18, subordinate=22, sec-latency=0
I/O behind bridge: 0000f000-00000fff
Memory behind bridge: c6900000-c6bfffff
Prefetchable memory behind bridge: 00000000fff00000-000000000000ffff
Secondary status: 66MHz- FastB2B- ParErr- DEVSEL=fast >TAbort- <TAbort- <SERR- <PERR-
BridgeCtl: Parity+ SERR+ NoISA- VGA- MAbort- >Reset- FastB2B-
PriDiscTmr- SecDiscTmr- DiscTmrStat- DiscTmrSERREN-
Capabilities: [40] Power Management version 3
Flags: PMEClk- DSI- D1- D2- AuxCurrent=0mA PME(D0+,D1-,D2-,D3hot+,D3cold+)
Status: D0 NoSoftRst+ PME-Enable- DSel=0 DScale=0 PME-
Capabilities: [48] MSI: Enable+ Count=1/8 Maskable+ 64bit+
Address: 00000000fee00478 Data: 0000
Masking: 000000ff Pending: 00000000
Capabilities: [68] Express (v2) Upstream Port, MSI 00
DevCap: MaxPayload 2048 bytes, PhantFunc 0
ExtTag- AttnBtn- AttnInd- PwrInd- RBE+ SlotPowerLimit 25.000W
DevCtl: Report errors: Correctable+ Non-Fatal+ Fatal+ Unsupported+
RlxdOrd- ExtTag- PhantFunc- AuxPwr- NoSnoop+
MaxPayload 256 bytes, MaxReadReq 128 bytes
DevSta: CorrErr- UncorrErr- FatalErr+ UnsupReq+ AuxPwr- TransPnd-
LnkCap: Port #4, Speed 8GT/s, Width x16, ASPM L1, Exit Latency L0s <4us, L1 <4us
ClockPM- Surprise- LLActRep- BwNot-
LnkCtl: ASPM Disabled; Disabled- CommClk-
ExtSynch- ClockPM- AutWidDis- BWInt- AutBWInt-
LnkSta: Speed 8GT/s, Width x16, TrErr- Train- SlotClk- DLActive- BWMgmt- ABWMgmt-
DevCap2: Completion Timeout: Not Supported, TimeoutDis-, LTR+, OBFF Via message
DevCtl2: Completion Timeout: 50us to 50ms, TimeoutDis-, LTR-, OBFF Disabled
LnkCtl2: Target Link Speed: 8GT/s, EnterCompliance- SpeedDis-
Transmit Margin: Normal Operating Range, EnterModifiedCompliance- ComplianceSOS-
Compliance De-emphasis: -6dB
LnkSta2: Current De-emphasis Level: -6dB, EqualizationComplete+, EqualizationPhase1+
EqualizationPhase2+, EqualizationPhase3+, LinkEqualizationRequest-
Capabilities: [a4] Subsystem: PLX Technology, Inc. Device 8796
Capabilities: [100 v1] Device Serial Number ab-87-00-10-b5-df-0e-00
Capabilities: [fb4 v1] Advanced Error Reporting
UESSta: DLP- SDES- TLP- FCP- CmpltTO- CmpltAbrt- UnxCmpl- RxOF- MalfTLP- ECRC- UnsupReq+ ACSViol-
UEMsk: DLP- SDES- TLP- FCP- CmpltTO- CmpltAbrt- UnxCmpl- RxOF- MalfTLP- ECRC- UnsupReq+ ACSViol-
UESvrt: DLP+ SDES+ TLP- FCP+ CmpltTO- CmpltAbrt+ UnxCmpl- RxOF+ MalfTLP+ ECRC- UnsupReq+ ACSViol-
CESta: RxErr- BadTLP- BadDLLP- Rollover- Timeout- NonFatalErr-
CEMsk: RxErr- BadTLP- BadDLLP- Rollover- Timeout- NonFatalErr+
AERCap: First Error Pointer: 1f, GenCap+ CGenEn- ChkCap+ ChkEn-
Capabilities: [138 v1] Power Budgeting <?>
Capabilities: [10c v1] #19
Capabilities: [148 v1] Virtual Channel
Caps: LPEVC=0 RefClk=100ns PATEntryBits=8
Arb: Fixed- WRR32- WRR64- WRR128-
Ctrl: ArbSelect=Fixed
Status: InProgress-
VC0: Caps: PATOffset=03 MaxTimeSlots=1 RejSnoopTrans-
Arb: Fixed- WRR32- WRR64+ WRR128- TWRR128- WRR256-
Ctrl: Enable+ ID=0 ArbSelect=WRR64 TC/VC=01
Status: NegoPending- InProgress-
Port Arbitration Table <?>
Capabilities: [e00 v1] #12
Capabilities: [b00 v1] Latency Tolerance Reporting
Max snoop latency: 0ns
Max no snoop latency: 0ns
Capabilities: [b70 v1] Vendor Specific Information: ID=0001 Rev=0 Len=010 <?>
Kernel driver in use: pcieport
```

To check the hierarchy or tree-like structure of PCIe slots / ports, type **lspci -vtt** OR **lspci -tv**, see output below.

```

T-11.0 Intel Corporation Xeon E7 v4/Xeon E5 v4/Xeon E3 v4/Xeon D Power Control Unit
\-[0000:00]-+00.0 Intel Corporation Xeon E7 v4/Xeon E5 v4/Xeon E3 v4/Xeon D DMI2
+01.0-[03-12]--+00.0-[14-22]----08.0-[15-22]----00.0-[16-22]----00.0-[17-22]----00.0-[18-22]--+00.0-[19]--
+02.0-[13-22]--+00.0-[14-22]----08.0-[15-22]----00.0-[16-22]----00.0-[17-22]----00.0-[18-22]--+01.0-[1a]--
+08.0-[1b]--
+09.0-[1c]--
+0c.0-[1d]--
+0d.0-[1e]--
+10.0-[1f]--
+11.0-[20]--
+14.0-[21]--
\15.0-[22]---
+00.1 PLX Technology, Inc. Device 87d0
+00.2 PLX Technology, Inc. Device 87d0
+00.3 PLX Technology, Inc. Device 87d0
\00.4 PLX Technology, Inc. Device 87d0
+03.0-[23-39]----00.0 LSI Logic / Symbios Logic MegaRAID SAS-3 3108 [Invader]
    
```

**PCIe slots (Downstream Ports)**

The picture below depicts the port number corresponding to physical slot on the backplane. The upstream port is on B/D/F **17:00.0** (Bus#, Device#,Function#), and below the upstream port are the downstream ports (Port 0, 1, 8, 9, 16, 17, 20 and 21).

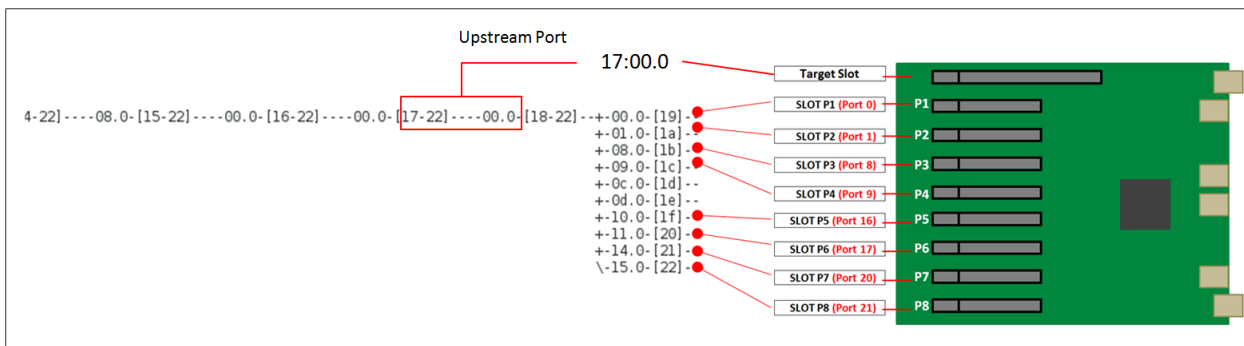

## 6 PCIe cards Installation

This chapter provides information on how to install 3<sup>rd</sup> party PCIe cards into your One Stop Systems expansion chassis. More details on the installation of individual cards are provided by the card's manufacturer. This chapter is provided as a simple guide to help you install your PCIe cards in the chassis.

For the purpose of installation, the One Stop Systems expansion chassis functions exactly as a standard desktop computer chassis. Always follow the manufacturer's instructions for installing their card or hard drive on a desktop computer.



### CAUTION

Hardware installation shall be performed only by qualified service personnel per UL and IEC 60950-1.



### IMPORTANT

We will provide reasonable technical support with 3<sup>rd</sup> Party PCIe cards. However, if you have verified a successful installation of the One Stop Systems expansion system, but experience difficulty installing your 3<sup>rd</sup> Party PCIe cards, the card manufacturer should be able to provide the best support.

### 6.1 Power Down System

You must turn OFF or power down the system before you start installing PCIe cards. After you have completely power down the system, disconnect or remove the power cords and cables from the back of the expansion chassis.

### 6.2 Open PCIe Expansion Chassis

Unscrew the four screws on the front of the unit and slide the lid towards the front you as shown below:



Remove slot covers

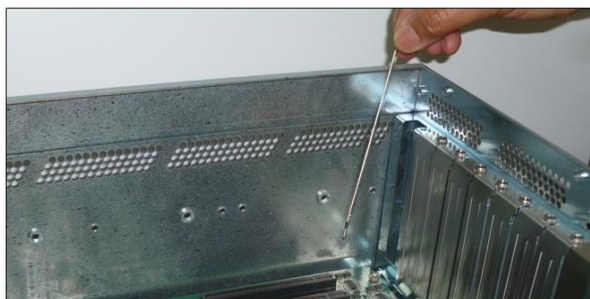

## 6.3 Install PCI Express (PCIe) Cards



Warning

### Electrostatic Discharge (ESD) Warning

All add-in cards are susceptible to electrostatic discharge. When moving cards, it is best to carry the cards in anti-static packaging. If you need to set a circuit card down, be sure to place it inside or on top of an anti-static surface. For more information, see [“Protecting Against Electrostatic Discharge”](#) in the Preface.



Warning

### WARNING

High voltages are present inside the expansion chassis when the unit’s power cord is plugged into an electrical outlet. Disconnect the power cord from the AC outlet before removing the enclosure cover. Turning the system power off at the power on/off switch does not remove power to components. High voltage is still present.



Caution

### CAUTION

Before touching anything inside the enclosure, move to an ESD station and follow proper ESD procedures. Failure to do so may result in electrostatic discharge, damaging the computer or its components. For more information, see [“Protecting Against Electrostatic Discharge”](#) in the Preface.



Caution

### CAUTION

Before installing add-in cards, please ensure that the input current rating specified on the AC input label is not exceeded.



Important

### IMPORTANT

This configuration is not applicable to run x16 GPUs or any high-end GPUs

When installing PCIe cards into the One Stop Systems expansion chassis, it makes no difference which PCIe slot you place your cards in. Usually that is determined by accessibility and heat dissipation consideration as may be specified by the card manufacturer.

**NOTE:** Be sure to install the PCIe cards following the card manufacturer’s recommendations. Some PCIe card manufacturers recommend that you install their software driver(s) prior to installing the hardware. If this is the case, you should install their driver or software before you connect and power up the expansion chassis.

The backplane PCIe slot can accommodate x2, x4, x8 and x16 PCIe cards. You can combine or mix different types of PCIe cards. For example, you can install 8 PCIe nvme cards on the 1<sup>st</sup> backplane and FPGA cards on the 2<sup>nd</sup> board

To install PCIe card, align the card on top of the slot. Gently push the card down until it is firmly seated. Make sure that all PCIe cards are secured.

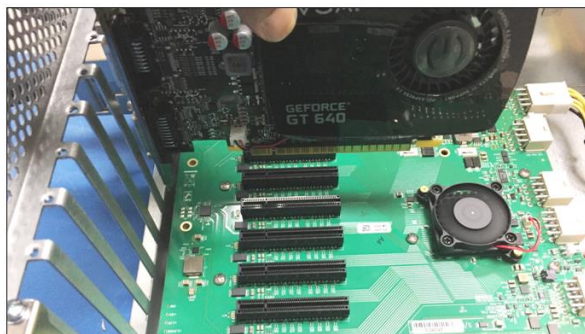

To keep the cards in place, secure them in the enclosure with their retaining screws (supplied with the One Stop Systems expansion chassis).



The photos below are few examples of different combinations of PCIe cards that you can install in the 4u value 8-slot expansion unit.

Sample 1: All PCIe slots are populated with x8 PCIe / GPU cards.

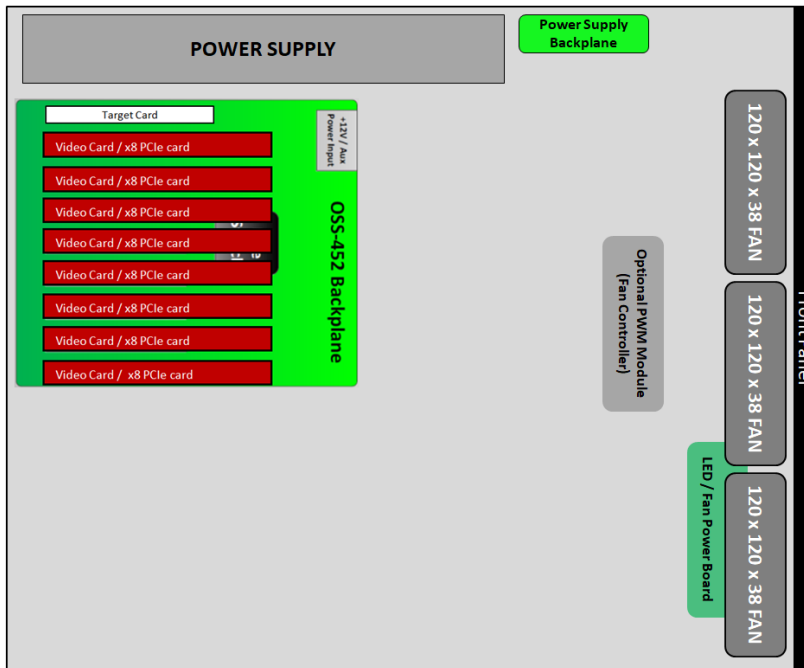

Sample 2: All PCIe slots are populated with SSD NVME PCIe cards

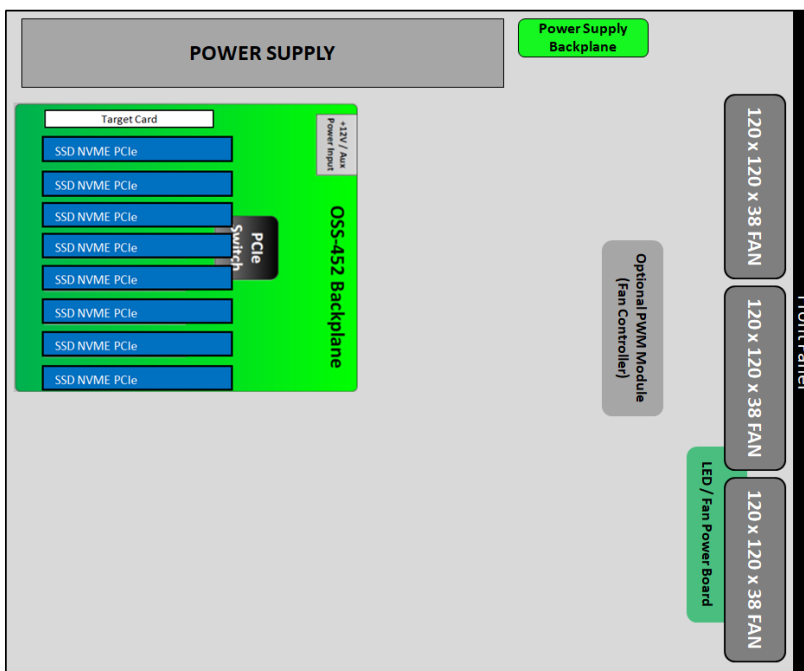

Sample 3: Populated with mixed x8 and x4 PCIe cards.

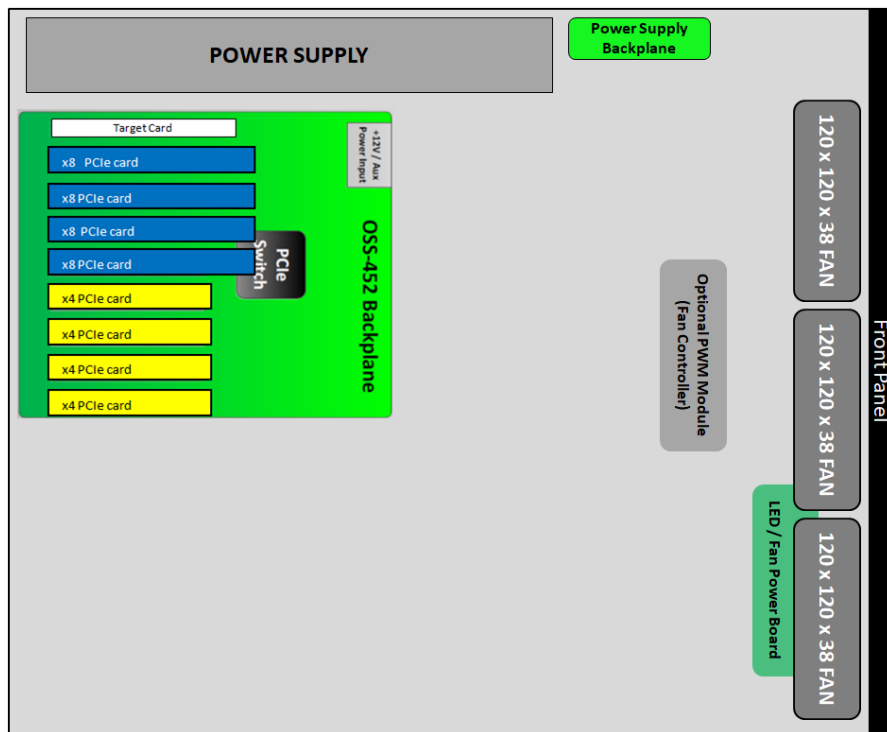

**IMPORTANT**

The sheer number of PCIe cards and device drivers available makes it impossible for One Stop Systems to fully test and certify all available PCIe cards for use in the One Stop Systems expansion chassis. Our best advice to you in this regard is to insist on full PCIe Specification compliance from your card and system vendors. Cards and systems should be at least PCIe Specification Revision 1.0 compliant or better. Compliance in your system motherboard, PCIe cards, and console firmware (or BIOS) is your best assurance that everything will install and operate smoothly.

- **This model of 4UV expansion unit is not applicable to run high-end GPUs.**
- **If you are planning to use a full length x16 GPUs, you need a different expansion unit. The solution is to use the “ 4U Value GPU Accelerator System (Model:OSS-PCIe-4UV-10-2), which is capable of running multiple high-end GPU application.**
- **Contact our Sales Team to find out more info on this product.**

## 6.4 Re-install top cover

Re-install top cover when done installing all your PCIe cards to allow proper airflow.

## 6.5 Apply Power

Reconnect the power cords to the back of the expansion unit. Reconnect the link cables, make sure both are firmly attached to the interface cards (Host and Target cards), then power up the computer.

The system should be up and running, the next step is to check and verify whether the PCIe cards are detected or not. Use the procedures detailed in Chapter 7 to confirm the card installation(s) in the Windows Device Manager or Linux or Mac OS.

## 7 PCIe HW & SW Verification

### 7.1 Verify PCIe Hardware

After the system is powered up, check inside the unit and pay attention on the slot LEDs. You should see all LEDs are illuminated, see pictures below. This is an indication that a card in the slot is recognized and detected. Depending on the type of PCIe card that is present in the slot will dictate the LED behavior. If there is no card present in the slot, the slot LED will be OFF.

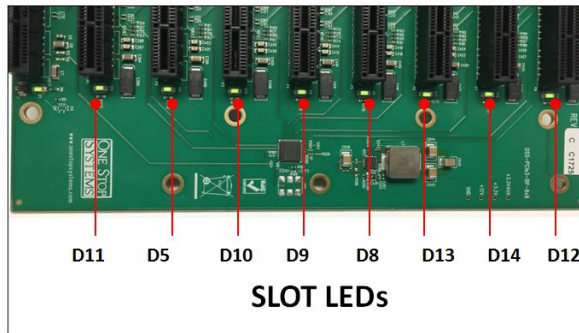

#### 7.1.1 Slot LED Status indicators

- Off - Link is down; no PCIe card installed
- Slow blink - Link is up at Gen1 (1Hz)
- Fast blink - Link is up at Gen2 (2Hz)
- On (solid) - Link is up at Gen 3 speed

Check the LINK LEDs on both Host and Target cards. Make sure you have a solid green LEDs on CBL and EDG. If only one LED is lit, this is an indication that you are not getting a good link between host and expansion unit. If this occurs, the host computer will not be detecting or recognizing your PCIe cards in the expansion unit.

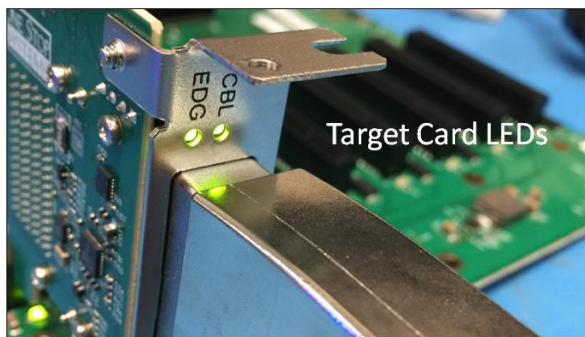

**CAUTION**

Re-install top cover when done checking to allow proper airflow

## 7.2 Check PCIe cards on Windows OS

When everything is functioning correctly, your Windows Device Manager should look something like the screenshot below. It represents one expansion board / backplane (either the 1<sup>st</sup> or 2<sup>nd</sup> backplane) attached to one specific host computer.

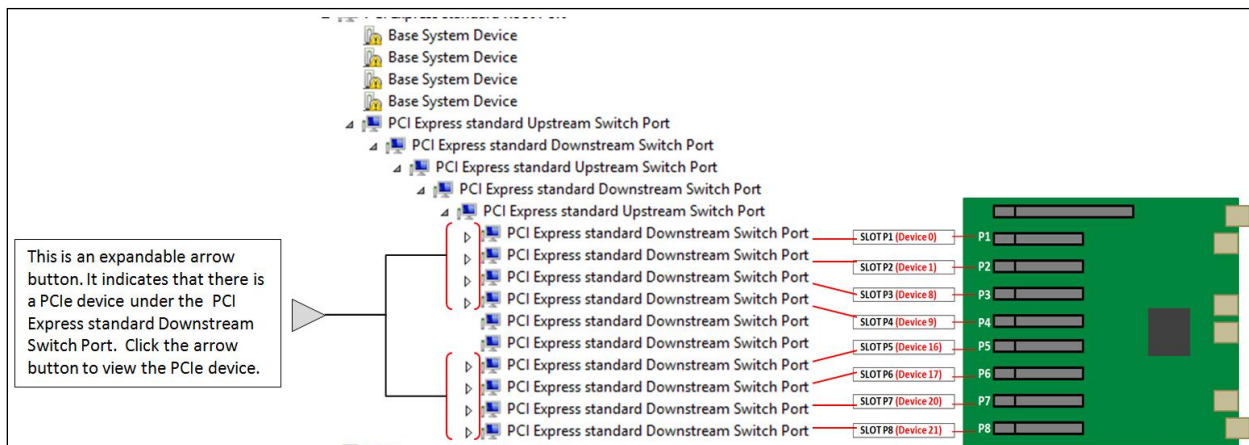

Expanding the arrow button will reveal the detected PCIe device or PCIe card beneath the PCI Express standard Downstream Switch Port. The example photo below shows eight PCIe cards that are detected and no errors (no yellow exclamation point). This means all the PCIe cards are working correctly.

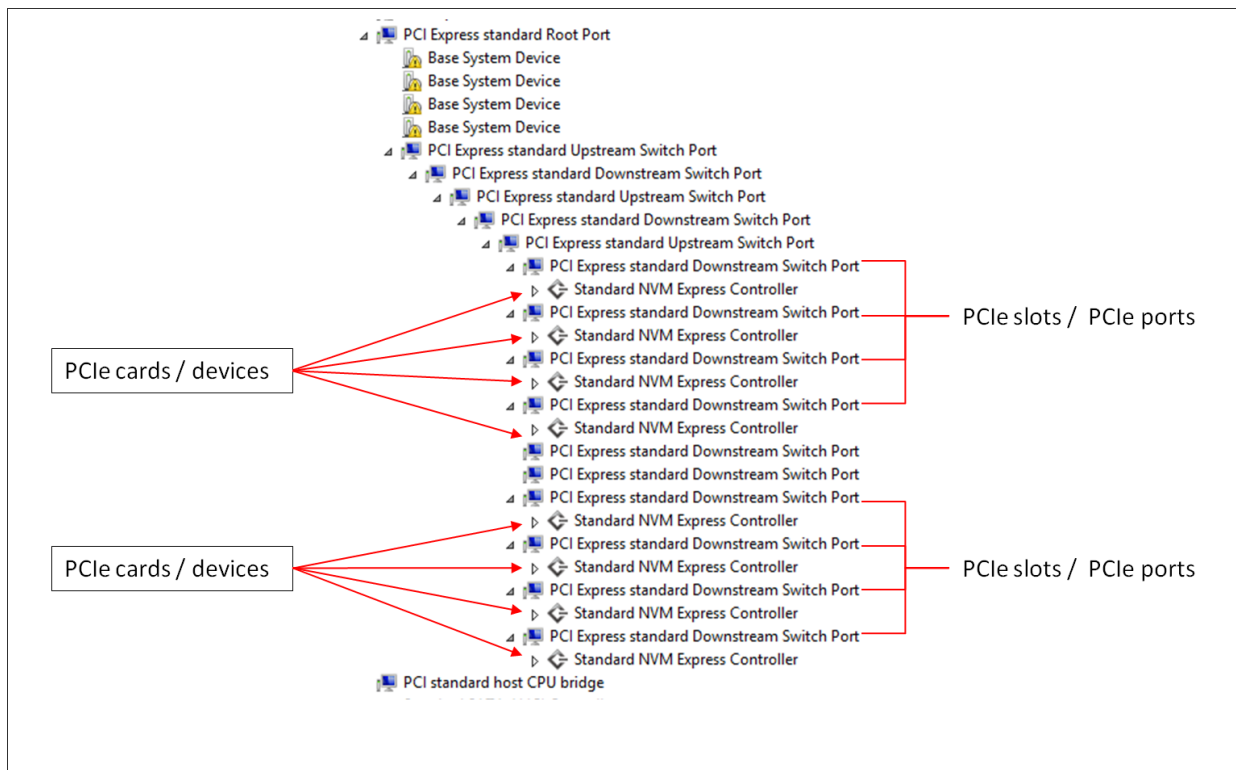

If you have two expansion boards attached to one specific host computer, in Windows Device manager it will show up two instances of 10 PCI Express standard Downstream Switch Ports and with an expandable arrow button, see photos below.

Expandable arrow button indicates that there is a PCIe device under the PCI Express standard Downstream Switch Port, these are the PCIe cards installed in the expansion chassis (via PCIe slot). Click the arrow button to view the PCIe device.

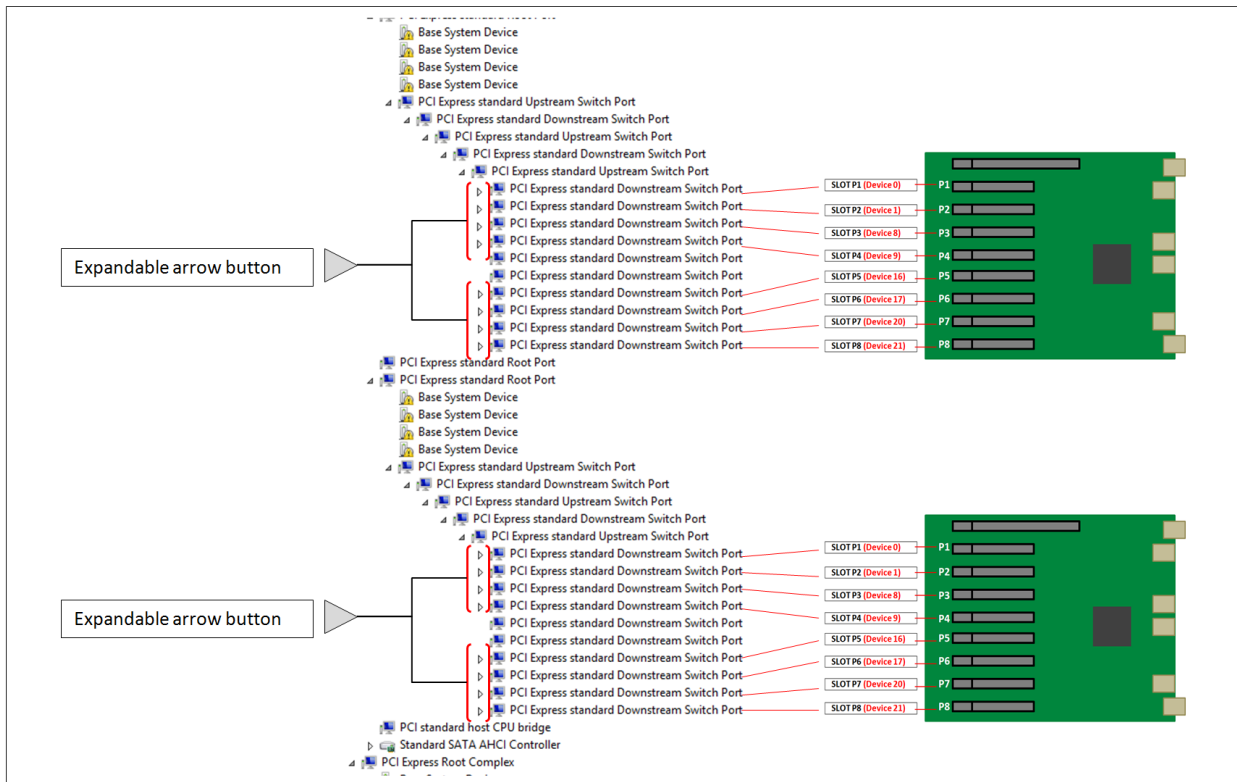

The photo below is an example of a device or PCIe card that is coming up with an exclamation point, which signifies error. This error could be attributed to several things such as a. card missing driver b. software of the card is incorrect c. corrupted driver d. failed to initialize d. card faulty e. not compatible with Operating System. To identify the error, right click the device with your mouse and then select properties, this will show the error code number. See photo below.

**Note:** If the PCIe card or device requires driver, you need to contact the vendor or manufacturer of the card. One Stop Systems is not responsible for supplying or providing the software / driver for the PCIe card.

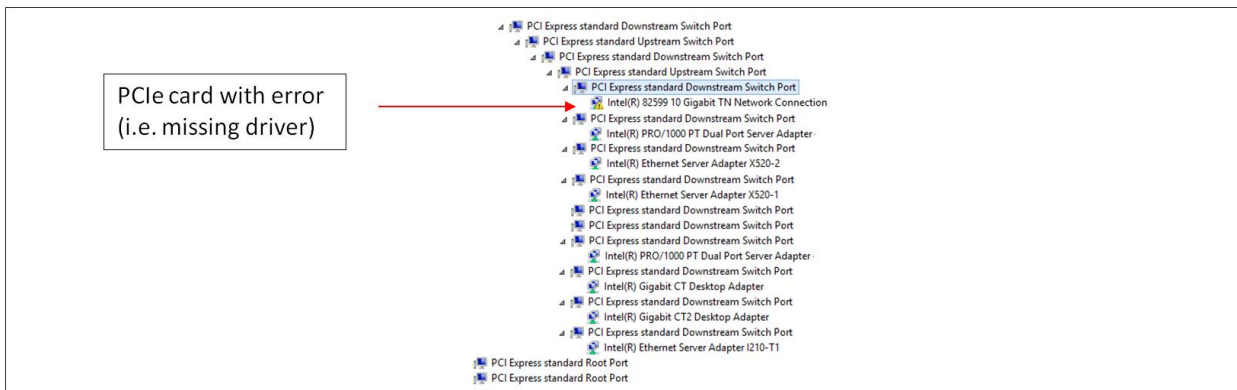

### 7.3 Check PCIe cards on Linux OS

To check on PCIe cards / devices, type **lspci -vtt** or **lspci -tv**

In this example, eight PCIe NMVE ssd cards that are enumerated / detected. These are the devices / cards that are installed in the expansion unit, see picture below.

```

\-.1f.2 Intel Corporation Xeon E7 v4/Xeon ES v4/Xeon E3 v4/Xeon D Power Control Unit
\-[0000:00]-+-.00.0 Intel Corporation Xeon E7 v4/Xeon ES v4/Xeon E3 v4/Xeon D DMI2
+-.01.0-[03-12]--
+-.02.0-[13-22]--+-.00.0-[14-22]-----.08.0-[15-22]-----.00.0-[16-22]-----.00.0-[17-22]-----.00.0-[18-22]--+-.00.0-[19]-----.00.0 HGST, Inc. Device 0023
+-.01.0-[1a]-----.00.0 HGST, Inc. Device 0023
+-.08.0-[1b]-----.00.0 HGST, Inc. Device 0023
+-.09.0-[1c]-----.00.0 HGST, Inc. Device 0023
+-.0c.0-[1d]--
+-.0d.0-[1e]--
+-.10.0-[1f]-----.00.0 HGST, Inc. Device 0023
+-.11.0-[20]-----.00.0 HGST, Inc. Device 0023
+-.14.0-[21]-----.00.0 HGST, Inc. Device 0023
\-.15.0-[22]-----.00.0 HGST, Inc. Device 0023

+-.00.1 PLX Technology, Inc. Device 87d0
+-.00.2 PLX Technology, Inc. Device 87d0
    
```

**8 PCIe cards detected**

The picture below represents the tree-like structure of PCIe cards and corresponding slot and port numbers.

```

-----.00.0-[17-22]-----.00.0-[18-22]--+-.00.0-[19]-----.00.0 HGST, Inc. Device 0023
+-.01.0-[1a]-----.00.0 HGST, Inc. Device 0023
+-.08.0-[1b]-----.00.0 HGST, Inc. Device 0023
+-.09.0-[1c]-----.00.0 HGST, Inc. Device 0023
+-.0c.0-[1d]--
+-.0d.0-[1e]--
+-.10.0-[1f]-----.00.0 HGST, Inc. Device 0023
+-.11.0-[20]-----.00.0 HGST, Inc. Device 0023
+-.14.0-[21]-----.00.0 HGST, Inc. Device 0023
\-.15.0-[22]-----.00.0 HGST, Inc. Device 0023
    
```

The following photos are an examples of a single PCIe card enumerated / detected in each slot.

#### PCIe Card detected in slot P8

```

son E3 v4/Xeon D Power Control Unit
son E3 v4/Xeon D DMI2

-.00.0-[16-22]-----.00.0-[17-22]-----.00.0-[18-22]--+-.00.0-[19]--
+-.01.0-[1a]--
+-.08.0-[1b]--
+-.09.0-[1c]--
+-.0c.0-[1d]--
+-.0d.0-[1e]--
+-.10.0-[1f]--
+-.11.0-[20]--
+-.14.0-[21]--
\-.15.0-[22]-----.00.0 Intel Corporation I210 Gigabit Network Connection

ce 87d0
ce 87d0
ce 87d0
ce 87d0
MegaRAID SAS-3 3108 [Invader]
    
```

**1 PCIe card detected in slot P8**

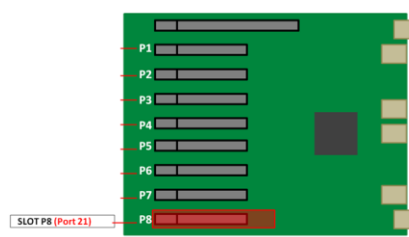

#### PCIe Card detected in slot P7

```

son E3 v4/Xeon D Power Control Unit
son E3 v4/Xeon D DMI2

-.00.0-[16-22]-----.00.0-[17-22]-----.00.0-[18-22]--+-.00.0-[19]--
+-.01.0-[1a]--
+-.08.0-[1b]--
+-.09.0-[1c]--
+-.0c.0-[1d]--
+-.0d.0-[1e]--
+-.10.0-[1f]--
+-.11.0-[20]--
+-.14.0-[21]-----.00.0 Intel Corporation I210 Gigabit Network Connection
\-.15.0-[22]--

ce 87d0
ce 87d0
ce 87d0
ce 87d0
MegaRAID SAS-3 3108 [Invader]
    
```

**1 PCIe card detected in slot P7**

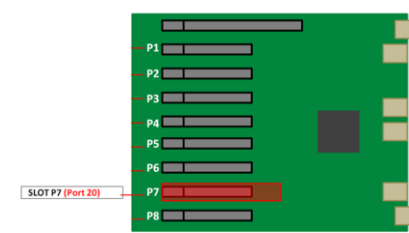

**PCIe Card detected in slot P6**

```

Xeon E3 v4/Xeon D Power Control Unit
Xeon E3 v4/Xeon D DMI2
--00.0-[16-22]---00.0-[17-22]---00.0-[18-22]--+00.0-[19]--
+01.0-[1a]--
+08.0-[1b]--
+09.0-[1c]--
+0c.0-[1d]--
+0d.0-[1e]--
+10.0-[1f]--
+11.0-[20]---00.0 Intel Corporation I210 Gigabit Network Connection
+14.0-[21]--
\15.0-[22]--

ice 87d0
ice 87d0
ice 87d0
ice 87d0
c: MegaRAID SAS-3 3108 [Invader]
    
```

1 PCIe card detected in slot P6

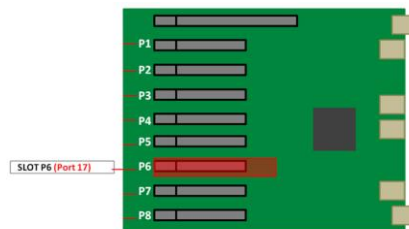

**PCIe Card detected in slot P5**

```

Xeon E3 v4/Xeon D Power Control Unit
Xeon E3 v4/Xeon D DMI2
--00.0-[16-22]---00.0-[17-22]---00.0-[18-22]--+00.0-[19]--
+01.0-[1a]--
+08.0-[1b]--
+09.0-[1c]--
+0c.0-[1d]--
+0d.0-[1e]--
+10.0-[1f]---00.0 Intel Corporation I210 Gigabit Network Connection
+11.0-[20]--
+14.0-[21]--
\15.0-[22]--

ice 87d0
ice 87d0
ice 87d0
ice 87d0
c: MegaRAID SAS-3 3108 [Invader]
    
```

1 PCIe card detected in slot P5

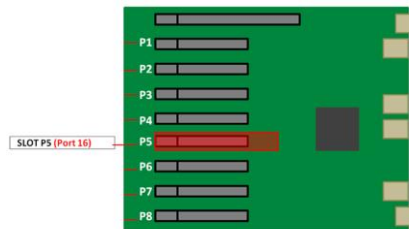

**PCIe Card detected in slot P4**

```

Xeon E3 v4/Xeon D Power Control Unit
Xeon E3 v4/Xeon D DMI2
--00.0-[16-22]---00.0-[17-22]---00.0-[18-22]--+00.0-[19]--
+01.0-[1a]--
+08.0-[1b]--
+09.0-[1c]---00.0 Intel Corporation I210 Gigabit Network Connection
+0c.0-[1d]--
+0d.0-[1e]--
+10.0-[1f]--
+11.0-[20]--
+14.0-[21]--
\15.0-[22]--

ice 87d0
ice 87d0
ice 87d0
ice 87d0
c: MegaRAID SAS-3 3108 [Invader]
    
```

1 PCIe card detected in slot P4

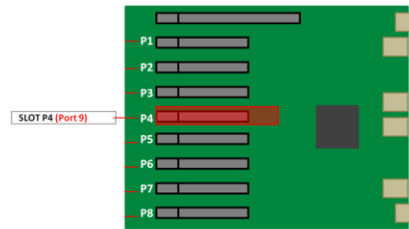

**PCIe Card detected in slot P3**

```

Xeon E3 v4/Xeon D Power Control Unit
Xeon E3 v4/Xeon D DMI2
00.0-[16-22]---00.0-[17-22]---00.0-[18-22]--+00.0-[19]--
+01.0-[1a]--
+08.0-[1b]---00.0 Intel Corporation I210 Gigabit Network Connection
+09.0-[1c]--
+0c.0-[1d]--
+0d.0-[1e]--
+10.0-[1f]--
+11.0-[20]--
+14.0-[21]--
\15.0-[22]--

ice 87d0
ice 87d0
ice 87d0
    
```

1 PCIe card detected in slot P3

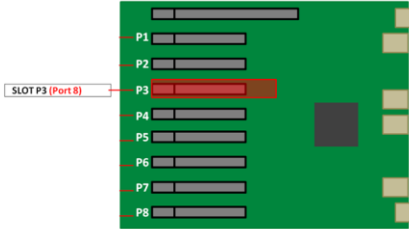

**PCIe Card detected in slot P2**

```

Xeon E3 v4/Xeon D Power Control Unit
Xeon E3 v4/Xeon D Power Control Unit
Xeon E3 v4/Xeon D DMI2
00.0-[16-22]---00.0-[17-22]---00.0-[18-22]--+00.0-[19]--
+01.0-[1a]---00.0 Intel Corporation I210 Gigabit Network Connection
+08.0-[1b]--
+09.0-[1c]--
+0c.0-[1d]--
+0d.0-[1e]--
+10.0-[1f]--
+11.0-[20]--
+14.0-[21]--
\15.0-[22]--

ice 87d0
ice 87d0
ice 87d0
ice 87d0
    
```

1 PCIe card detected in slot P2

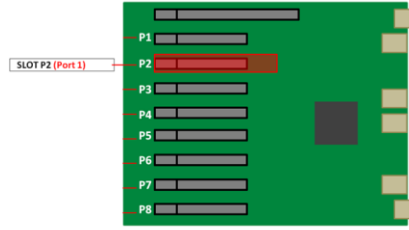



**PCIe Card detected in slot P1**

```
on:~# lspci -n -s 00:00:00 -d pci:v000080C0-sub:000080C0-dev:00000000 class=net-cards
on E3 v4/Xeon D DMiZ
00:00-[16-22]----00:0-[17-22]----00:0-[18-22]---+00:0-[19]---00:0 Intel Corporation I210 Gigabit Network Connection
+01:0-[1a]--
+08:0-[1b]--
+09:0-[1c]--
+0c:0-[1d]--
+0d:0-[1e]--
+10:0-[1f]--
+11:0-[20]--
+14:0-[21]--
\15:0-[22]--
e 87d0
e 87d0
e 87d0
e 87d0
MegaBAY0 SAS-3 3108 [Invader]
```

1 PCIe card detected in slot P1

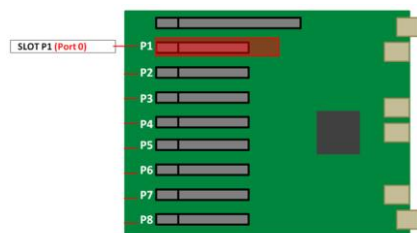

To display the details of the single device, you would need the BDF numbers (Bus, Device, Function numbers). For example, looking at the screenshot below, 22 is the BUS number, 00 is the Device number and 0 is the function number.

```
[14-22]----08:0-[15-22]----00:0-[16-22]----00:0-[17-22]----00:0-[18-22]---+00:0-[19]--
+01:0-[1a]--
+08:0-[1b]--
+09:0-[1c]--
+0c:0-[1d]--
+0d:0-[1e]--
+10:0-[1f]--
+11:0-[20]--
+14:0-[21]--
\15:0-[22]----00:0 Intel Corporation I210 Gigabit Network Connection
```

BUS# 22, Device# 00, Function# 0

To only show the details for the Intel NIC device you would run `lspci -s 22:00.0 -vvv` on the terminal window, see output below

```
[root@sca05-0a81fd86 ~]# lspci -s 22:00.0 -vvv
22:00.0 Ethernet controller: Intel Corporation Ethernet Server Adapter I210-T1
Subsystem: Intel Corporation Ethernet Server Adapter I210-T1
Control: I/O- Mem+ BusMaster+ SpecCycle- MemWINV- VGASnoop- ParErr+ Stepping- SERR+ FastB2B- DisINTx+
Status: Cap+ 66MHz- UDF- FastB2B- ParErr- DEVSEL=fast >TAbort- <TAbort- <MAbort- >SERR- <PERR- INTx-
Latency: 0, Cache Line Size: 64 bytes
Interrupt: pin A routed to IRQ 39
Region 0: Memory at c6a00000 (32-bit, non-prefetchable) [size=1M]
Region 3: Memory at c6b00000 (32-bit, non-prefetchable) [size=16K]
Expansion ROM at c6900000 [disabled] [size=1M]
Capabilities: [40] Power Management version 3
Flags: PMEClk- DSI+ D1- D2- AuxCurrent=0mA PME(D0+,D1-,D2-,D3hot+,D3cold+)
Status: D0 NoSoftRst+ PME-Enable- Dsel=0 DScale=1 PME-
Capabilities: [50] MSI: Enable- Count=1/1 Maskable+ 64bit+
Address: 0000000000000000 Data: 0000
Masking: 00000000 Pending: 00000000
Capabilities: [70] MSI-X: Enable+ Count=5 Masked-
Vector table: BAR=3 offset=00000000
PBA: BAR=3 offset=00002000
Capabilities: [a0] Express (v2) Endpoint, MSI 00
DevCap: MaxPayload 512 bytes, PhantFunc 0, Latency L0s <512ns, L1 <64us
ExtTag- AttnBtn- AttnInd- PwrInd- RBE+ FLReset+
DevCtl: Report errors: Correctable+ Non-Fatal+ Fatal+ Unsupported+
RlxdOrd- ExtTag- PhantFunc- AuxPwr- NoSnoop+ FLReset-
MaxPayload 256 bytes, MaxReadReq 512 bytes
DevSta: CorrErr- UncorrErr- FatalErr- UnsuppReq- AuxPwr+ TransPend-
LnkCap: Port #21, Speed 2.5GT/s, Width x1, ASPM L0s L1, Exit Latency L0s unlimited, L1 <16us
ClockPM- Surprise- LLActRep- BwNot-
LnkCtl: ASPM Disabled; RCB 64 bytes Disabled- CommClk-
ExtSynch- ClockPM- AutWidDis- BWInt- AutBWInt-
LnkSta: Speed 2.5GT/s, Width x1, TrErr- Train- SlotClk+ DLActive- BWMgmt- ABWMgmt-
DevCap2: Completion Timeout: Range ABCD, TimeoutDis+, LTR-, OBFF Not Supported
DevCtl2: Completion Timeout: 65ms to 210ms, TimeoutDis-, LTR-, OBFF Disabled
LnkCtl2: Target Link Speed: 2.5GT/s, EnterCompliance- SpeedDis+
Transmit Margin: Normal Operating Range, EnterModifiedCompliance- ComplianceSOS-
Compliance De-emphasis: -6dB
LnkSta2: Current De-emphasis Level: -6dB, EqualizationComplete-, EqualizationPhase1-
EqualizationPhase2-, EqualizationPhase3-, LinkEqualizationRequest-
Capabilities: [100 v2] Advanced Error Reporting
UESSta: DLP- SDES- TLP- FCP- CmpltTO- CmpltAbrt- UnxCmplt- RxOF- MalfTLP- ECRC- UnsupReq- ACSViol-
UESMsk: DLP- SDES- TLP- FCP- CmpltTO- CmpltAbrt- UnxCmplt- RxOF- MalfTLP- ECRC- UnsupReq+ ACSViol-
UESvrt: DLP+ SDES+ TLP- FCP+ CmpltTO+ CmpltAbrt+ UnxCmplt- RxOF+ MalfTLP+ ECRC- UnsupReq+ ACSViol-
CESSta: RxErr- BadTLP- BadDLLP- Rollover- Timeout- NonFatalErr-
CEMsk: RxErr- BadTLP- BadDLLP- Rollover- Timeout- NonFatalErr+
AERCap: First Error Pointer: 00, GenCap+ CGenEn- ChkCap+ ChkEn-
Capabilities: [140 v1] Device Serial Number a0-36-9f-ff-66-8d-69
Capabilities: [1a0 v1] Transaction Processing Hints
Device specific mode supported
Steering table in TPH capability structure
Kernel driver in use: igb
```

To check just the port number, slot number, bandwidth and speed, type the command on the terminal `lspci -s 22:00.0 -vvv | grep 'Slot\|Port'`, see output below.

```
[root@sca05-0a81fd86 ~]# lspci -s 22:00.0 -vvv | grep 'Slot\|Port'
LnkCap: Port #21, Speed 2.5GT/s, Width x1, ASPM L0s L1, Exit Latency L0s unlimited, L1 <16us
LnkSta: Speed 2.5GT/s, Width x1, TrErr- Train- SlotClk+ DLActive- BWMgmt- ABWMgmt-
```

To check for speed only, type `lspci -s 22:00.0 -vvv | grep 'LnkSta'`

```
[root@sca05-0a81fd86 ~]# lspci -s 22:00.0 -vvv | grep 'LnkSta'
LnkSta: Speed 2.5GT/s, Width x1, TrErr- Train- SlotClk+ DLActive- BWMgmt- ABWMgmt-
LnkSta2: Current De-emphasis Level: -6dB, EqualizationComplete-, EqualizationPhase1-
```

To check for port number, type `lspci -s 22:00.0 -vvv | grep 'LnkCap'`

```
[root@sca05-0a81fd86 ~]# lspci -s 22:00.0 -vvv | grep 'LnkCap'
LnkCap: Port #21, Speed 2.5GT/s, Width x1, ASPM L0s L1, Exit Latency L0s unlimited, L1 <16us
```

## 7.4 Check PCIe cards on Mac OS

When using Mac OS X no additional software or drivers are needed. As long as you are using Mac OS X Version 10.9 or newer, the operating system should automatically recognize the Magma expansion chassis.

Select "About This Mac" under the Apple Icon. Then click the "More Info" button → click on System Report → select PCI as shown below:



Upon selecting the "PCI Cards", you should see all the available PCIe cards that are in the expansion unit. The One Stop Systems devices are transparent to the Operating System, you will only see the PCIe cards that are in the expansion slots.

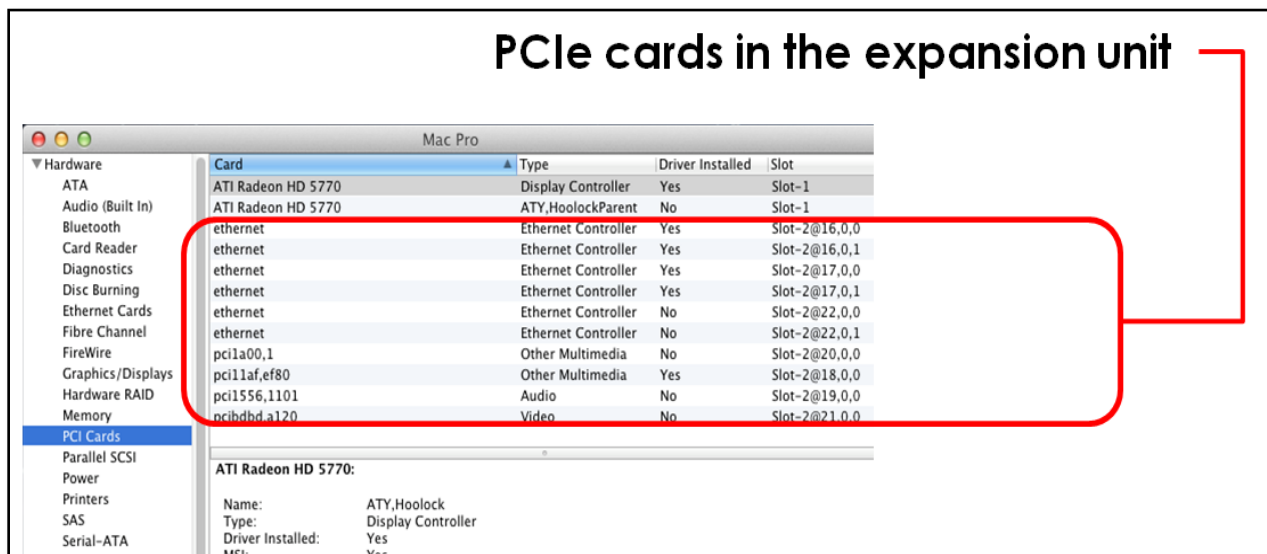

If any of these devices are not displayed as shown above, you should shut down your system (computer first, then the expansion chassis) and reconnect the cables and the PCIe expansion host card to ensure that you have a solid connection. Then restart the One Stop Systems expansion chassis followed by the computer.

## 8 General & Other Technical Information

### 8.1 Target and Host cards

**Host adapter** (aka: HIB - Host Interface Board)

The host adapter (aka: Host Interface card) is installed into the host computer’s PCIe x16 slot. The host cable adapter (Part # OSS-PCIe-HIB38-x16-H) allows communication between a processor and an I/O point.

**Target adapter** (aka: Target Card, Expansion Interface Card)

The target card(Part# OSS-PCIe-HIB38-x16-T) fits into an OSS custom slot backplane and extends the PCIe bus to a single add-in board via a PCIe x16 cable. The “Target Card” can only be installed in a designated/ specific slot on the backplane.

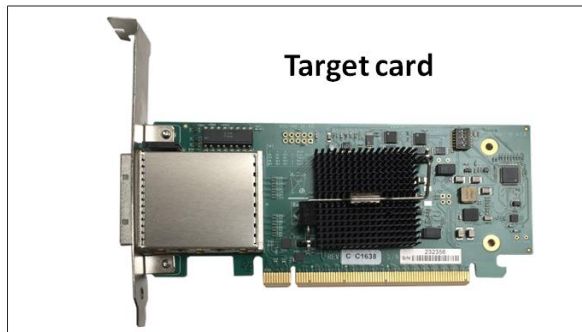
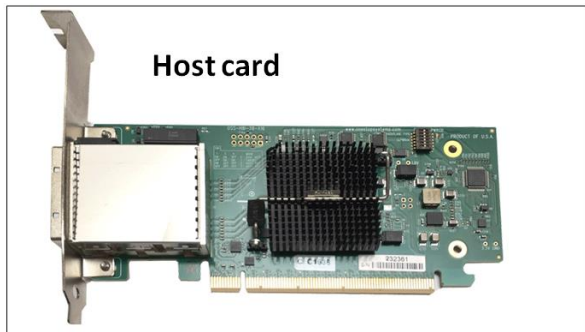

#### 8.1.1 Specifications

Form Factor	PCIe half card
Operating Temperature	0°C to +50°C environment.
Storage Temperature	-40°C to 85°C
Operating Humidity	10% to 90% relative humidity non-condensing
Storage Humidity	5% to 95% relative humidity non-condensing
Power	15W
Connectors	PCIe x16 cable connector
Industry Specifications	<ul style="list-style-type: none"> <li>• PCIe External Cabling Specification, Rev. 2.0</li> <li>• PCI Express™ Card Electromechanical Specification, Rev. 3.0</li> <li>• PCI Express® Base Specification, Rev. 3.0</li> </ul>
PCB	PCI Express add-in card standard PCIe x16 cable PCB thickness .063 +/-0.008 inch (1.6 +/- 0.2mm) Mounting holes for face plate
Switch	Broadcom PEX8733
Bracket	<ul style="list-style-type: none"> <li>• Standard and low profile brackets available</li> <li>• Two LEDs on bracket</li> </ul>
Agency Compliance	<ul style="list-style-type: none"> <li>• FCC Class A</li> <li>• CE</li> <li>• RoHS</li> </ul>

### 8.1.2 Dimension

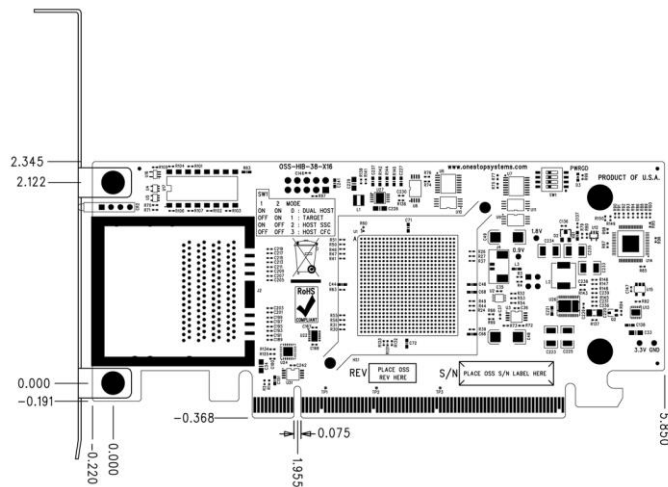

### 8.1.3 Card LEDs

Multiple LEDs and Dip switches make debugging and troubleshooting easy. Visible CBL and EDGE LEDs show PCIe link STATUS that each PCIe Interface card is operating properly. Other LED for " Power Good -PWRGD" is useful visual indicator for troubleshooting and verifying the connections. A Gen3 LINK between host and targets card will show two Solid Green LEDs on the back of the card (CBL and EDG).

Solid – Gen 3	Fast blink - Gen 2	Slow blink - Gen1
---------------	--------------------	-------------------

1. **CBL LED** shows the link status between the host card in the host computer and the target card in the expansion chassis.
2. **EDGE LED shows:**
  - a. HOST card – connection between host card and host system.
  - b. TARGET card – connection between the switch on the target card and the switch in the expansion chassis
3. **PWRGD LED** shows electrical power is present

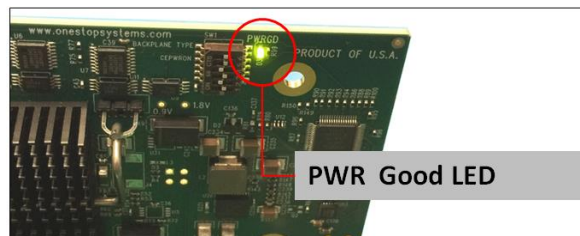

### 8.1.4 Card Mode Settings

The interface card is x16-capable and it can be used interchangeably as Host card or Target card as long as the Dip switches are set correctly. The Dip switch (**SW1**) allows you to change what mode the interface card can be running. When the card is used as host card, all the dipswitches should be set off position, see photo below.

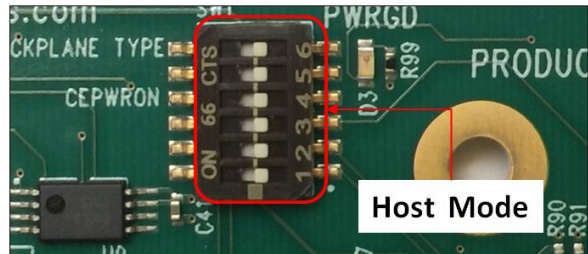
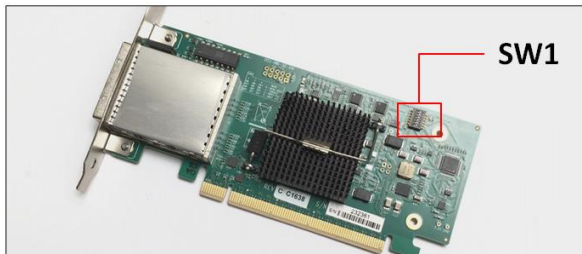

When using as “Target Card”, set the dipswitches to the following settings, see photo below.

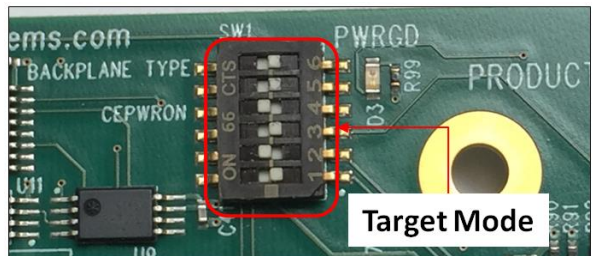
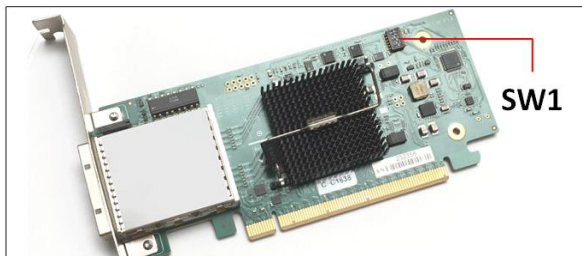

### 8.1.6 Pin Assignments

#### Connectors Gen3 PCIe x16 Card Edge Connector

- The pins are numbered as shown with side A on the top of the centerline on the solder side of the board and side B on the bottom of the centerline on the component side of the board.
- The PCIe interface pins PETpx, PETnx, PERpx, and PERnx are named with the following convention: “PE” stands for PCIe high speed, “T” for Transmitter, “R” for Receiver, “p” for positive (+), and “n” for negative (-).
- Note that adjacent differential pairs are separated by two ground pins to manage the connector crosstalk

### 8.1.7 Pin-out for the Gen3 PCIe x16 Card Edge Connector

PIN#	SIDE B		SIDE A	
	Name	Description	Name	Description
1	N/C	Not Connected	PRSNT1#	Hot-Plug presence detect
2	N/C	Not Connected	N/C	Not Connected
3	N/C	Not Connected	N/C	Not Connected
4	GND	Ground	GND	Ground
5	N/C	Not Connected	N/C	Not Connected
6	N/C	Not Connected	JTAG3	TDI (Test Data Input)
7	GND	Ground	JTAG4	TDO (Test Data Output)
8	+3.3V	3.3V power	N/C	Not Connected
9	N/C	Not Connected	N/C	Not Connected
10	3.3Vaux	3.3V auxiliary power	+3.3V	3.3V power
11	N/C	Not Connected	PERST#	Fundamental Reset
<b>MECHANICAL KEY</b>				
12	RSVD	Reserved	GND	Ground

13	GND	Ground	REFCLK+	Reference Clock (Differential Pair)
14	PETp0	Transmitter differential pair, Lane 0	REFCLK	
15	PETn0			GND
16	GND	Ground	PERp0	Receiver Differential Pair, Lane 0
17	PRSENT2#	Hot-Plug presence detect	PERn0	
18	GND	Ground	GND	Ground
19	PETp1	Transmitter differential pair, Lane 1	RSVD	Reserved
20	PETn1			GND
21	GND	Ground	PERp1	Receiver Differential Pair, Lane 1
22	GND	Ground	PERn1	
23	PETp2	Transmitter differential pair, Lane 2	GND	Ground
24	PETn2			GND
25	GND	Ground	PERp2	Receiver Differential Pair, Lane 2
26	GND	Ground	PERn2	
27	PETp3	Transmitter differential pair, Lane 3	GND	Ground
28	PETn3			GND
29	GND	Ground	PERp3	Receiver Differential Pair, Lane 3
30	RSVD	Reserved	PERn3	
31	PRSENT2#	Hot-Plug presence detect	GND	Ground
32	GND	Ground	RSVD	Reserved

### Signal Descriptions

PETp(x)	PCI Express Transmit Positive signal of (x) pair
PETn(x)	PCI Express Transmit Negative signal of (x) pair
PERp(x)	PCI Express Receive Positive signal of (x) pair
PERn(x)	PCI Express Receive Negative signal of (x) pair
CREFLK+/-	Cable Reference Clock: Provides a reference clock from the host systems to the remote systems
SB_RTN	Side Band ReTurn: return path for single ended signals from remote systems
CPRSNT#	Cable PreSent: Indicates the presence of a device beyond the cable
PWR	PoWer: Provides local power for in-cable redriver circuits. Only needed on long cables. Power does not go across the cable
PWR_RTN	PoWer ReTurn: Provides local power return path for PWR pins.
CWAKE#	Cable Wake
CPERST#	Cable PCI Express Reset

## 8.2 452 Backplane

The OSS target backplane supports a PCIe Gen3 target cable adapter installed in the OSS target slot and up to eight PCIe x8 expansion cards installed in the expansion slots. Slots are backward compatible and support Gen1 and Gen2 cards. OSS target backplanes only support OSS target adapters installed the target slot of the backplane. OSS PCIe backplanes support expansion cards designed to the PCIe PCI-SIG specification. This backplane operates with ATX power.

### Specifications:

Dimension (H xL)	7.5" x 9.0
Power	ATX
Slots	One OSS PCIe x16 3.0 target slot for OSS target cable adapter. Eight PCIe x8 3.0 expansion slots (x8 open-ended mechanical).

### 8.2.1 PCIe Slots and Ports Assignment

Each PCIe slot has its own port assignment, see picture below. There are 9 PCIe slots per backplane (452 model), one occupied by the “Target Card” and 8 slots are available. All slots have their own corresponding port. The port assignment are hard-coded, you cannot change or modify this information. For example, a single GPU or PCIe card that is plugged into slot P2 on the backplane, port 1 will be automatically assigned to the card.

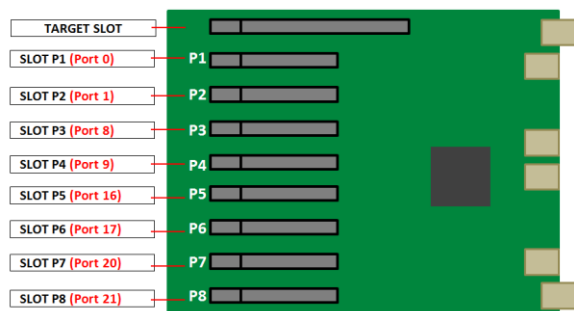

### 8.2.2 Dimension

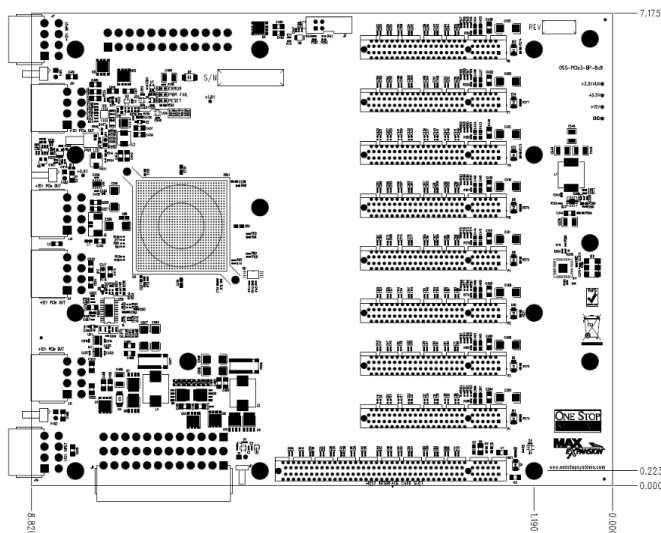



### 8.2.3 Parts 452 backplane

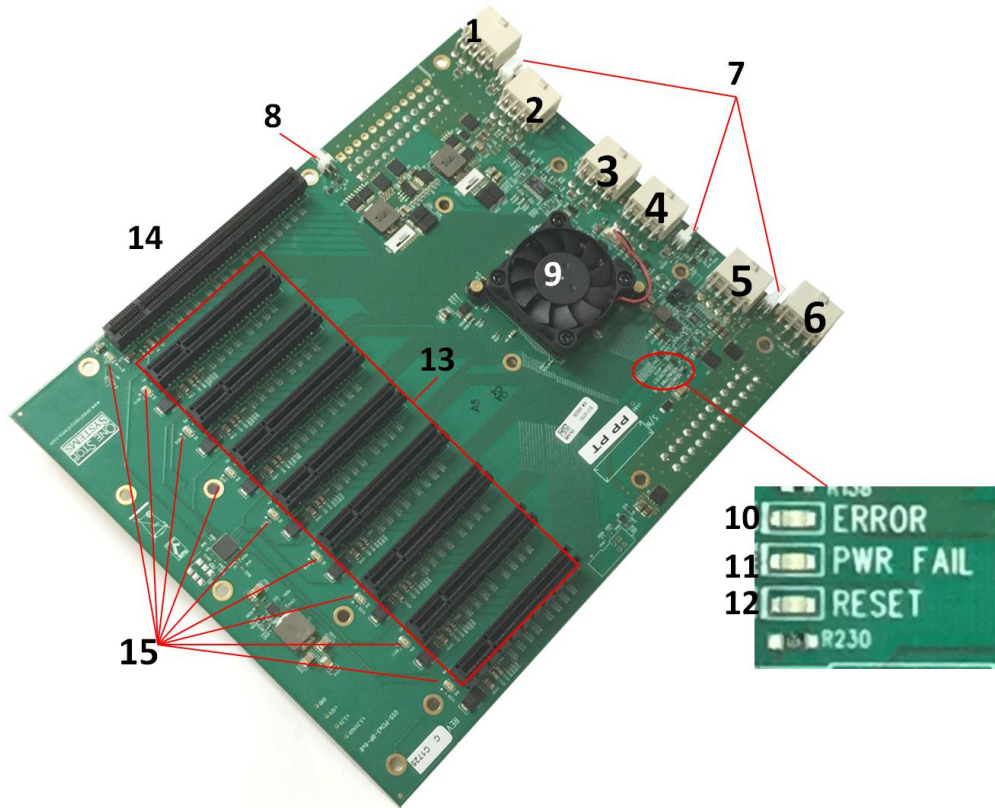

Item#	Name	Description
1	J14	12V input power for the 452 board when used in all configurations.
2	J11	12V output power for GPU (not used in Value Chassis)
3	J4	12V output power for GPU (not used in Value Chassis)
4	J12	12V output power for GPU (not used in Value Chassis)
5	J10	12V output power for GPU (not used in Value Chassis)
6	J7	12V input power for the 452 board when used in a Cube configuration
7	FAN1,FAN2, FAN3	fan connectors
8	J1	FORCE PWRON (engineering/debug use only)
9	PCIe Switch & Fan	PCIe Switch PEX8796, 96 Lane Switch & Fan
10	Error LED	State of the PEX8796 Fatal Error signal, Red means error has occurred
11	PWRFAIL	Output of the voltage monitor. Red means that one or more voltage rails are out of specification. Will automatically set PERST low
12	RESET	State of the PE_RST# signal. Red means that PERST is low
13	P1 to P8	PCIe slots (x8 lane) for cards. x8 Mechanical, x8 Electrical
14	P0	Target Slot ; Upstream Port. x16 Mechanical, x16 Electrical
15	Slot LEDs	PCIe Gen Speed LED Indicator (Gen1, Gen2, Gen3)

### 8.2.4 Card Slot Link LEDs

Each slot has its own corresponding LED indicators. It will signify the GEN speed of the card that is plugged in, see info below.

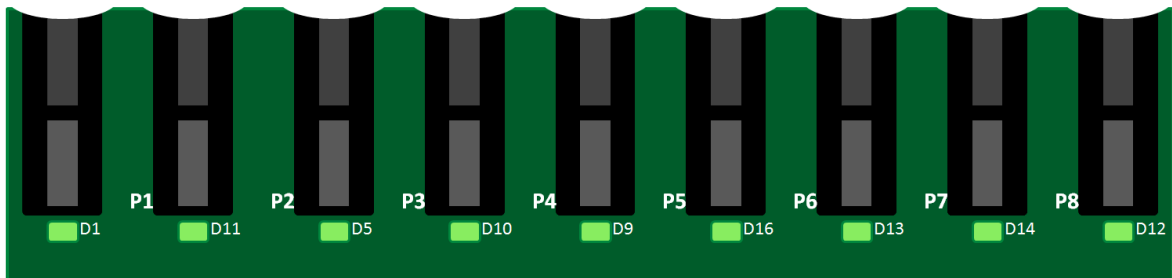

SLOT#	PORT	LED	Description	When Lit (Solid Green or blinking)	When Off
Slot P1	PORT 0	D11	Slot P1 Link	Solid - Gen 3 Link; Fast Blinking - Gen 2 Link, Slow Blinking - Gen 1 Link	OFF - Not Linked / No Card present in the slot
Slot P2	PORT 1	D5	Slot P2 Link	Solid - Gen 3 Link; Fast Blinking - Gen 2 Link, Slow Blinking - Gen 1 Link	OFF - Not Linked / No Card present in the slot
Slot P3	PORT 8	D10	Slot P3 Link	Solid - Gen 3 Link; Fast Blinking - Gen 2 Link, Slow Blinking - Gen 1 Link	OFF - Not Linked / No Card present in the slot
Slot P4	PORT 4	D9	Slot P4 Link	Solid - Gen 3 Link Fast Blinking - Gen 2 Link, Slow Blinking - Gen 1 Link	OFF – not Linked/ No Card present in the slot
Slot P5	PORT 16	D6	Slot P5 Link	Solid - Gen 3 Link Fast Blinking - Gen 2 Link, Slow Blinking - Gen 1 Link	OFF - Not Linked / No Card present in the slot
Slot P6	PORT 17	D13	Slot P6 Link	Solid - Gen 3 Link Fast Blinking - Gen 2 Link, Slow Blinking - Gen 1 Link	OFF - Not Linked / No Card present in the slot
Slot P7	PORT 20	D14	Slot P7 Link	Solid - Gen 3 Link Fast Blinking - Gen 2 Link, Slow Blinking - Gen 1 Link	OFF - Not Linked / No Card present in the slot
Slot P8	PORT 21	D12	Slot P8 Link	Solid - Gen 3 Link Fast Blinking - Gen 2 Link, Slow Blinking - Gen 1 Link	OFF - Not Linked / No Card present in the slot

### 8.2.5 Slot Type

Slot Type: open ended PCIe connector, x8 mechanical and x8 electrical. You can plug in x2, x4, x8 and x16 cards.

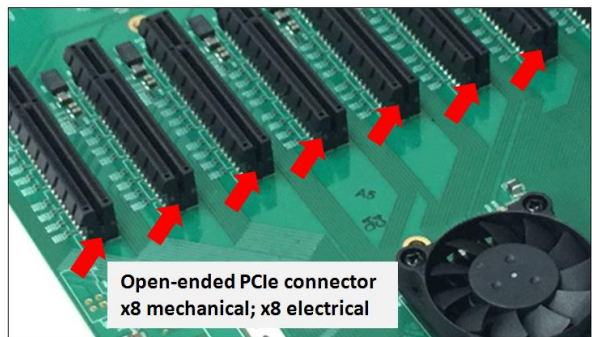
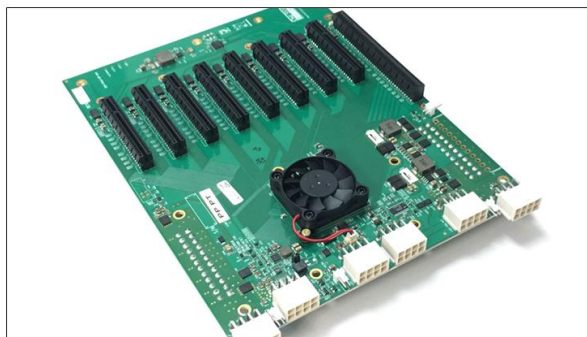

### 8.2.6 Force Power ON

The 452 board has a connector for a shunt / jumper which will force power on to the target. This is the J1 connector located next to the upstream slot where the Target card is plugged in.

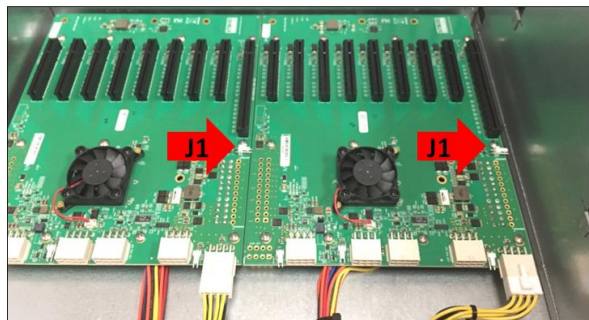
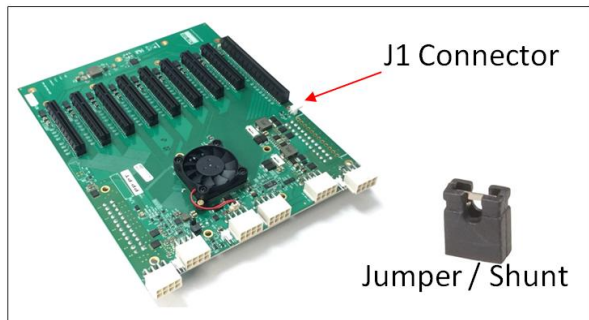

When using a different Gen3 cards such as HIB68-x16 (SFF-8644 cable connectors) plus Fiber Optic cables or / and NON-CMI cables (Mini SAS Cables) the backplane needs to be jumpered.

1. Place jumper on J1 connector.
2. Remove the target card first from the slot in order to access the J1 connector.
3. Place the jumper or shunt on pin 1 & 2 of the J1 connector, see photos below

With jumper / shunt on the backplane allows to force power ON the target.

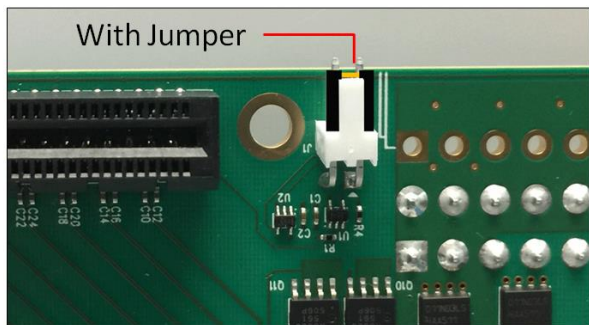
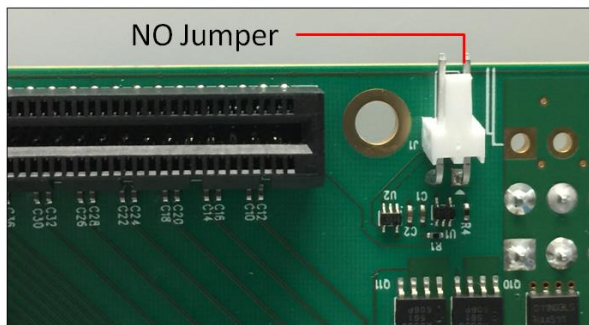

Using a NON-CMI cables and / or Fiber Optic cables the expansion needs to be turned on (full power) prior to the host turning on. This can be achieved by placing a jumper on the J1 connector ( PS-ON) of the backplane and sliding the FORCE-PWRON switch on the TARGET card to ON position. This will then allow the FPGA to generate a PERST for the target switch and the backplane switch as soon as the AC power is plugged in.

### 8.2.7 Connector Pin-Outs

Connector	Definition
J1	Force Power On
J3	I2C Interface
J4, J10, J11, J12	12V Output Power
J6, J7, J8, J14	Input Power
JP1, JP5	Power Standby LED
JP3	Fan Speed Control

J3 – I2C Interface Connector (3M P/N; 929710-10-02-RK)

Pin	Definition	Pin	Definition
1	SMCLK	2	GND
3	SMDAT	4	NC

J6, J8 – Input Power (Molex P/N: 87427-2402)

Pin	Definition	Pin	Definition
1	+3.3V	13	+3.3V
2	+3.3V	14	-12V
3	GND	15	GND
4	+5V	16	PS_ON#
5	GND	17	GND
6	+5V	18	GND
7	GND	19	GND
8	PWRON	20	NC
9	+5VSB	21	+5V
10	+12V1	22	+5V
11	+12V1	23	+5V
12	+3.3V	24	GND

J1 – Force Power On (Molex P/N: 22-05-3021)

Pin	Definition
1	PWR_ON#
2	GND

J4, J10, J11, J12 – 12V Output Power (Molex P/N: 87427-0802)

Pin	Definition	Pin	Definition
1	GND	5	+12V
2	GND	6	+12V
3	GND	7	+12V
4	GND	8	+12V

J7, J14 – Input Power (Molex P/N: 87427-0802)

Pin	Definition	Pin	Definition
1	GND	5	+12V
2	GND	6	+12V
3	GND	7	+12V
4	GND	8	+12V

JP1, JP5 – Power Standby LED (Samtec P/N; TFM-102-01-L-S-RA)

Pin	Definition
1	+3.3VAUX
2	GND

FAN1, FAN2, FAN3 – Fan Speed Control (Molex P/N: 22-05-3021)

Pin	Definition
1	FAN_12V_PU
2	FAN_RTN

### 8.3 Using Fiber Optic Cables and HIB68-x16 card

You can use fiber optic cables (15 meter and 100 meter) with the HIB68-x16 cards (both host and target ).

- The HIB68-16 card requires a different EEPROM when using the Fiber Optic cable.
- The HIB68-x16 cards (host and target) have standard EEPROM that works with the PCIe 3.0 CMI cables and SFF-8644 copper cables.
- You need to upgrade the EEPROM on the target and host cards in order for the “fiber optic cables” to work. **It support x4, x8 and x16 configurations.**

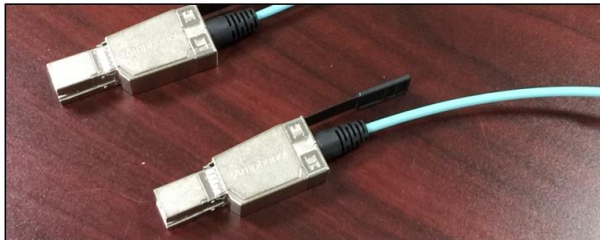

Make sure to connect all four cables correctly to host and target cards

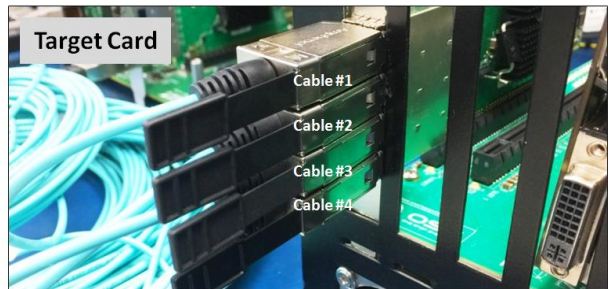
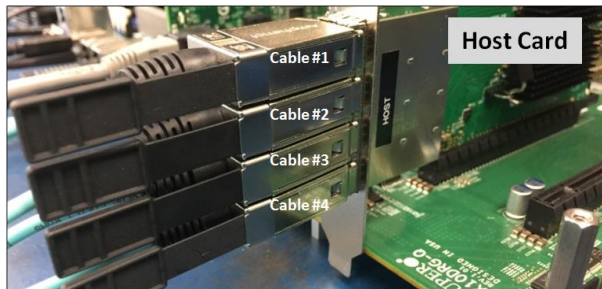

Set the dipswitch settings accordingly on both Host and Target cards.

#### Switch Definitions

	OFF	ON
SW1-1	Host Mode	Target Mode
SW1-2	Power enabled by Host	Power is always enabled
SW1-3	EEPROM WP OFF	EEPROM WP ON
SW1-4	Using OSS Backplane	Using Magma Backplane
SW1-5	Auto Configuration Negotiation	Use SW2 for Manual Configuration

	SW2-1	SW1-2
	PC1	PC0
Manual x16	ON	ON
Manual x8x8	ON	OFF
Manual x8x4x4	OFF	ON
Manual x4x4x4x4	OFF	OFF

Host card dipswitch setting: SW1: #5=ON | SW2: #1=ON; #2=ON

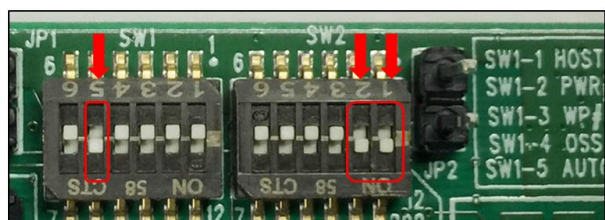
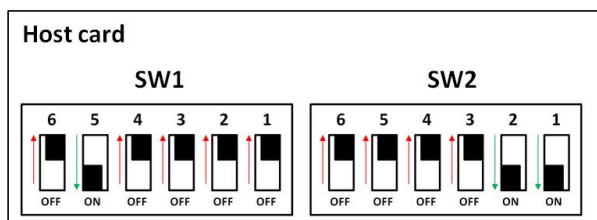

Target card dipswitch setting: SW1: #1=ON; #2=ON | SW2: All OFF

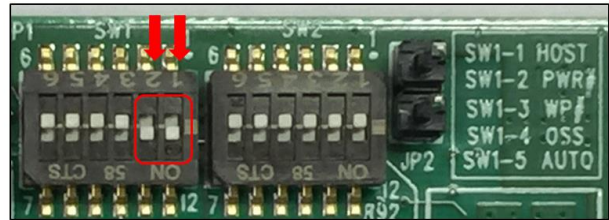
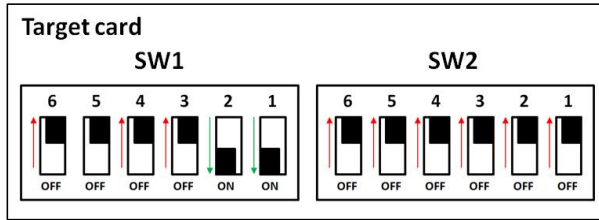

For more information on the HIB68-x16 card go to <https://www.onestopsystems.com/product/pcie-x16-gen3-cable-adapter>

## 8.4 Power Cords

Two types of power cords can be used with this expansion unit, 125V and 250V.



### 8.4.1 Specifications

OSS PART#: 290-001-012-RC		OSS PART#: 290-001-032-RC	
Description: CORD NEMA5-15P C-13SJT		Description: CORD PWR MALE-FEMALE SJT	
Part Status	Active	Part Status	Active
Style	Male pins (Blades) to Female Sockets (slots)	Style	Male pins (Blades) to Female Sockets (slots)
1 <sup>st</sup> Connector	NEMA 5-15P	1 <sup>st</sup> Connector	IEC 320-C14
2 <sup>nd</sup> Connector	IEC 320-C13	2 <sup>nd</sup> Connector	IEC 320-C13
Number of Conductors	3	Number of Conductors	3
Cord Type	SJT	Cord Type	SJT
Wire Gauge	14 AWG	Wire Gauge	14 AWG
Shielding	Unshielded	Shielding	
Approval Marks	CSA, UL	Approval Marks	CSA, UL
Approved Countries	Canada, USA	Approved Countries	
Voltage Rating	125V	Voltage Rating	250V
Current Rating	15A	Current Rating	15A
Operating Temperature	60°C	Operating Temperature	105°C
Digi-Key Part#	Q944-ND	Digi-Key Part#	1175-1312-ND

### 8.4.2 Power cord socket and voltage tables world standards

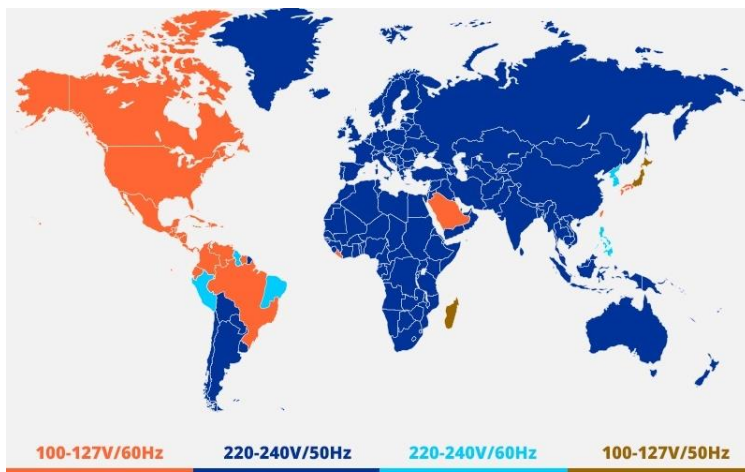

## 8.5 Link Cable

### PCIe x16 Cable

Available in 1m and 3m lengths with crossover cabling. The connectors on either end of the PCIe x16 cable are identical. Each connector is equipped with a retractor allowing the connector to be locked into place.



	Cable Gage	24	26	28
A	Cable Diameter	10.4	9.3	8.4
B	Minimum outer radius	46.9	41.7	37.7
C	Faceplate to outer radius	102.2	97	93

Unit:mm

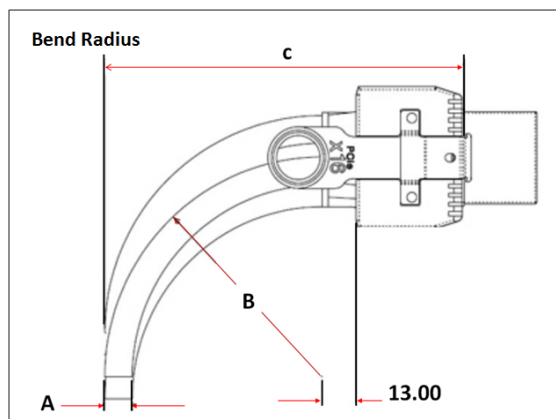

### 8.5.1 Specifications

General	
Connector to Connector	PCI Express-to-PCI Express
Physical	
Circuits (Loaded)	136
Circuits (Loaded)	136
Gender	Male-Male
Lock to Mating Part	Yes
Material - Metal	Zinc Alloy
Pitch - Mating Interface	0.80mm
Single Ended	No
Waterproof / Dustproof	YES
Wire Insulation Diameter	N/A
Wire/Cable Type	Round
Electrical	
Current - Maximum per Contact	1A
Shielded	Yes
Voltage - Maximum	30V DC
Other	
RoHS Compliant	Yes
Operating Temperature	-40 to +85°C



### 8.5.2 Cable Installation

1. Align the cable into the cable port. Push and hold the "latch Metal Tab" while slowly inserting the cable.
2. Release the tab so the connector teeth will snap securely into the holes of the cable shell, see photos below

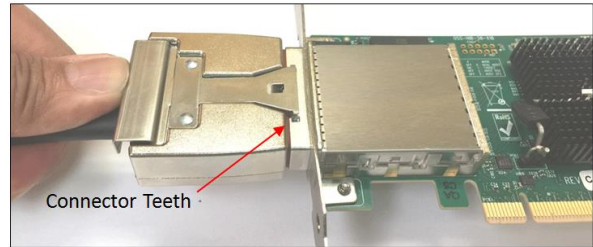

### 8.5.3 Cable Removal

1. Push or press and hold the "latch Metal Tab", to disengage the connector teeth. Slowly pull back the cable.

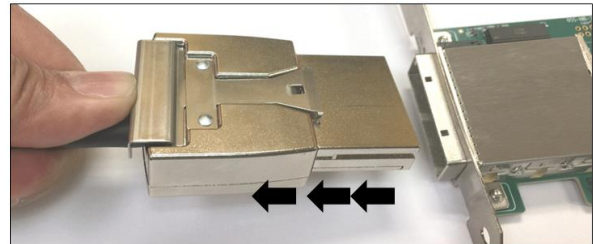
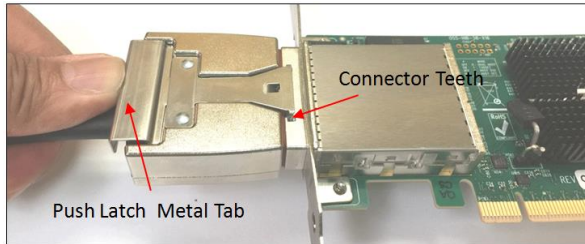

Pulling the cable out without disengaging the connector teeth will damage the cable.

## 8.5.4 Cable Pin-Outs Assignment

Designator	Description	Dimension (mm)	Tolerance (mm)
C01	Interface Width	28.40	±0.10
D01	Forward Edge of Plug to Forward Lower Tab	0.75	±0.13
D02	Slot Depth	6.79	±0.13
D04	Forward Lower Tab Width	25.53	±0.13
D06	Snout Length	28.31	±0.13
D07	Snout Width	34.44	+0.20/-0.05
D08	Latch Face Plane to Forward Edge of PCB	26.29	±0.20
D09	Plug Width	53.00	±0.05
D10	Plug Thickness	20.23	±0.13
D11	Top of Plug to Bottom of Snout	17.18	±0.13
D12	Side Rail Groove Length	27.60	±0.10
D13	Snout Thickness	9.99	+0.15/-0.05
D15	Thickness Top Forward Edge of Plug	0.80	±0.05
D16	Top of Rail Groove to Top of Tongue	6.83	+0.15/-0.05
D17	D17 Top of Snout to Top of Side Groove	2.50	±0.05
D18	Top of Side Groove to Centerline of Upper PCB	0.53	±0.13
D19	Side Rail Groove Width	2.05	±0.05
D21	Zone A Internal Width Rail Groove to Rail Groove	33.24	±0.05
D21	Zone B Internal Width Rail Groove to Rail Groove	32.74	±0.05
D23	Top of Side Groove to Centerline of Lower PCB	5.03	±0.13
D27	Latch Barb Spacing	17.50	±0.05
D28	Length of Zone A	21.54	±0.13
D29	Length of Zone B	5.00	±0.13
D30	Chamfer Width	0.30	±0.05
D31	Chamfer Length	1.00	±0.05
D32	Latch to Plug Body	1.60	±0.13
D33	Internal Plug Width	30.55	±0.10
D34	Chamfer Height	0.20	±0.05
D35	Chamfer Width	0.45	Min
D36	Pull Radius	4.00	±0.10
D37	Pull Inner Diameter	16.52	Min
D38	Pull Outer Diameter	23.02	Max
D39	Pull Centerline to Radius	13.97	±0.10
D40	Pull Centerline to Radius	20.67	±0.10
D41	Pull Centerline to Latch	63.57	±3.00
D42	Pull Thickness	1.25	Min
D43	Text Height - PCIe	2.70	Ref
D44	Text Height - x16	5.60	Ref

## 8.6 Power Supply

The 4u Value expansion chassis has an 80 Plus Titanium power supply capable of supplying 2000W output power at 91% efficiency. This power supply is designed to not only provide you reliable power but also protects it from over voltage, over current and short circuiting via protective circuitry embedded into the unit. It has a mean-time between failure (MTBF) of **greater than 200,000** hours and an LED indicator to keep you informed on normal/abnormal conditions for your PSU.

The power supply is redundant to safe-guard your system from power failure and allows for hot-swap replacement to eliminate system downtime. It includes two replaceable modules (ea 2000 W) that share the power load requirements during normal operations. All materials contained comply with RoHS requirements

- Should one module fail for any reason, the power load will be shifted to the other module.
- An indicator for the failure would be the LEDs on the back panel of the power supply behind the chassis.
- For non-functioning equipment, these indicators would not show.



### 8.6.1 Removing a hot-swap ac power supply

1. Disconnect the power cord from the power supply you are removing.
2. Grasp the power-supply handle.
3. Press the brown release latch to the right and hold it pressed down.
4. Pull the power supply part of the way out of the bay.
5. Release the release latch; then, support the power supply with your left hand and pull it the rest of the way out of the bay.
6. If you are instructed to return the power supply, follow all packaging instructions, and use any packaging materials for shipping that are supplied to you.



The power supply is an 80 Plus Titanium power supply capable of supplying 2000W output power at 91% efficiency. Enjoy the simplicity of active power factor correction (PFC) and automatically correct AC input for a full range of voltages. Features a card edge connector for connection with the backplane of compatible 1U systems. This power supply is designed to not only provide you reliable power to your server but also protects it from over voltage, over current and short circuiting via protective circuitry embedded into the unit. Rest easy knowing your hardware will be up and running with a mean-time between failure (MTBF) of greater than 200,000 hours and an LED indicator to keep you informed on normal/abnormal conditions for your PSU. This power supply is redundant to safe-guard your system from power failure and allows for hot-swap replacement to eliminate system downtime. All materials contained comply with RoHS requirements.

### 8.5.2 Specifications

General Specifications	
<b>Dimension</b>	346 x 76 x 40 mm (D x W X H)
<b>Total Max Power / Power Output</b>	1000 W @ 100-127Vac 1800 W @ 200-220Vac 1900 W @ 220-230Vac 2000 W @ 230-240Vac
<b>Hold-up Time</b>	11ms @ 75% load
<b>Efficiency</b>	at least 96% Peak @ 50% load
<b>MTBF</b>	200,000 hours @ 25 degree C
<b>PFC</b>	Yes
<b>PMBUS</b>	Support PMBus 1.2
<b>Internal Oring</b>	Yes
<b>N+1 Redundant</b>	Yes
<b>Cold Redundancy</b>	Yes
<b>Full Digital Power Supply</b>	Yes
<b>High Power Density</b>	39.7 W/in <sup>3</sup>
<b>Application</b>	HPC, Cloud Computing
<b>80 Plus Certification</b>	80 Plus Titanium

Input Specifications	
<b>Input Voltage</b>	90-264
<b>Input Frequency</b>	50-60Hz
<b>AC Input Rating (Voltage Range / Current Range/Frequency)</b>	
	2000 W (UL/CUL) 200-240V / 11.8-9.8A /50-60Hz
	1000W: 100-127V / 12-9.5A / 50-60Hz
	1800W: 200-220V / 10-9.5A / 50-60Hz
	1980W: 220-230V / 10-9.8A / 50-60Hz
	2000W: 230-240V / 10-9.8A / 50-60Hz

Output Specifications	
<b>DC Output Specifications (Voltage /Max Load)</b>	
	2000 W (UL/CUL) +12V / 166.7A ; +5Vsb /1A
	1000W: +12V / 83.3A ; +5Vsb / 1.0A
	1800W: +12V / 150 A ; +5Vsb / 1.0A
	1980W: +12V / 165 A ; +5Vsb / 1.0A
	2000W: +12V /166.7A ; +5Vsb / 1.0A
	+5V: N/A
	+3.3V : N/A

Environmental Specifications	
<b>Temperature</b>	0 to 50 degree C Operating
<b>Altitude</b>	16,5000 feet Operating
<b>Relative Humidity</b>	20% to 90% RH Operating

Safety Regulations	
	UL, cUL, BMSI, CQC, CB, CE, FCC Class A, CISPR Class A, ROHS

### 8.6.3 LED Indicator

- A green/amber double color Light Emitting Diode (LED) shall be mounted as indicated in mechanical drawing and shall indicate the status of the DC GOOD signal with green color.
- The LED shall continue to glow under normal operation of the power supply. If this LED is blinking or not lit or in amber color, the power supply is not operating properly.
- During protection mode ( main 12V rail), the LED should be amber.
- During protection mode ( 5Vsb rail), the LED should be off.
- When protection is cleared, the LED should go back to the original intended status.
- When the unit is in standby with AC is present, the LED should be amber.
- When the unit is in standby with no AC is present, the LED should be off.
- When the unit is turned on properly, the LED is green.
- During wakeup redundancy mode, the LED should be Green.

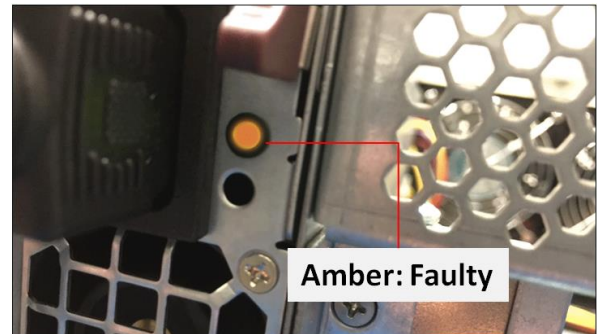
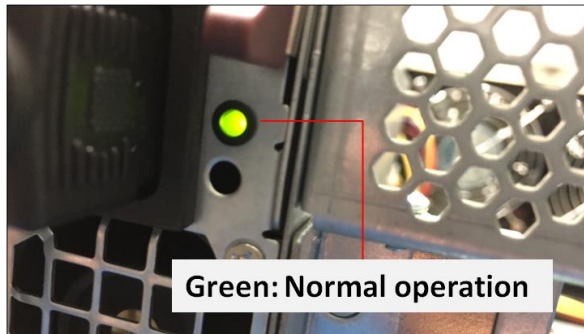

## 8.7 Fan

The expansion unit has three fans installed enough to provide cooling to the extreme-high-heat-generating GPUs. These are high CFM / RPM and replaceable fans. The standard or default fans have a fixed fan speed (3x lead wires). There is an optional fan that would allow you to control the speed. You can get the PWM controller and 4 wire fans.

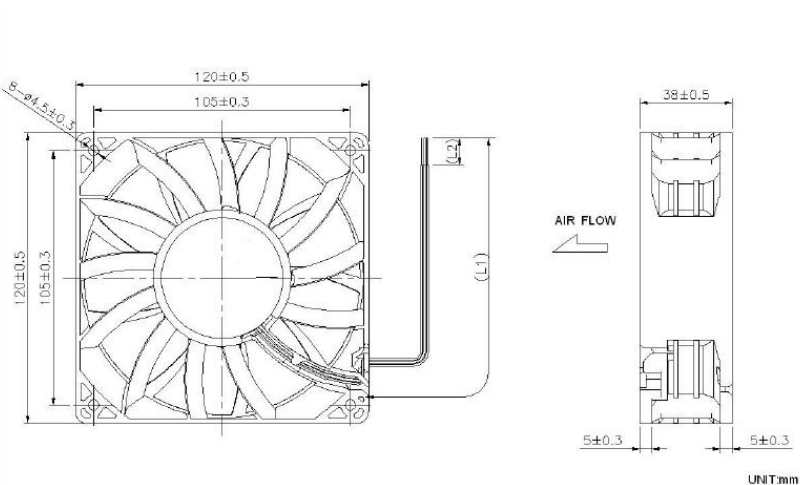

### 8.7.1 Fan Specifications

Part Number: 60-120-012-RC				Part Number: 60-120-011-RC			
4x Lead wires – PWM / Fan control (Controls Fan Speed)				3x Lead wires – Standard Fan ( Fixed Fan Speed)			
<b>Frame &amp; Impeller</b>	PBT, UL94V-O plastic			<b>Frame &amp; Impeller</b>	PBT, UL94V-O plastic		
<b>Dimension</b>	120x38mm (4.7”X1.5)			<b>Dimension</b>	120x38mm (4.7”X1.5)		
<b>Connection</b>	4x Lead wires			<b>Connection</b>	3x Lead wires		
<b>Motor</b>	Brushes DC, auto restart, polarity protected.			<b>Motor</b>	Brushes DC, auto restart, polarity protected.		
<b>Bearing System</b>	Dual ball bearing			<b>Bearing System</b>	Dual ball bearing		
<b>Insulation Resistance</b>	Min. 10M at 500VDC			<b>Insulation Resistance</b>	Min. 10M at 500VDC		
<b>Dielectric Strength</b>	1 minute at 500 VAC, max leakage< 500 MicroAmp			<b>Dielectric Strength</b>	1 minute at 500 VAC, max leakage< 500 MicroAmp		
<b>Temperature Range</b>	-10C~+70C			<b>Temperature Range</b>	-10C~+70C		
<b>Storage Temperature</b>	-40C~+80C			<b>Storage Temperature</b>	-40C~+80C		
<b>Life (L10)</b>	70,000 Hours (40C)			<b>Life (L10)</b>	70,000 Hours (40C)		
<b>Part Number</b>	OD1238-12HBXJ10A			<b>Part Number</b>	OD1238-12HBXJ10A		
<b>Nominal Voltage</b>	12V DC			<b>Nominal Voltage</b>	12V DC		
<b>Voltage Range</b>	7~13.2V DC			<b>Voltage Range</b>	7~13.2V DC		
<b>Rated Current</b>	3.70 A			<b>Rated Current</b>	3.70 A		
<b>Rated Power</b>	44.4 Watt			<b>Rated Power</b>	44.4 Watt		
<b>Rated Speed (RPM)</b>	6000			<b>Rated Speed (RPM)</b>	6000		
<b>Airflow (CFM)</b>	250			<b>Airflow (CFM)</b>	250		
<b>Noise Level (db)</b>	69			<b>Noise Level (db)</b>	69		
<b>Max. Static Pressure</b>	1.48” H <sup>2</sup> O			<b>Max. Static Pressure</b>	1.48” H <sup>2</sup> O		
<b>Weight</b>	~375 g			<b>Weight</b>	~375 g		
Tachometer – Open Collector   <b>PWM</b>				Tachometer – <b>Open Collector</b>			
*Connection UL1007, 24AWG, ~320mm				*Connection UL1007, 24AWG, ~320mm			
Red (+)	Black(-)	White: Tachometer	Blue: PWM	Red (+)	Black(-)	White Tachometer	

## 8.8 Auxiliary power cables

The aux power cable is available for the unit but it is not a standard item. It is optional and sold separately. If your card requires an extra power, please contact our Sales team.

There are two different sets of aux power cables, see table below.

	Part Number	Description	Connector	#of Connector
8 pin	290-010-037-RC-01	Cable Assy, Aux Pwr, 8 Pin, NVIDIA 2.0, 12", Expansion System, M176 (OSS)	8-pin male to 8-pin male	One 8-pin connector
	290-010-037-RC-02	Cable Assy, Aux Pwr, 8 Pin, NVIDIA 2.0, 24" Expansion System, M176 (OSS)	8-pin male to 8-pin male	One 8-pin connector
6+2 pin	290-010-013-RC	Cable Assy, Canister, External Pwr, Dual 6+2 PCIe Graphics Only	8-pin male to 2 6+2-pin male	Two 6+2 pin connectors
	290-010-036-RC	Cable Assy, Aux Pwr, 6+2 Pin, 24", Expansion System, M176 (OSS)	8-pin male to 2 6+2-pin male	Two 6+2 pin connectors



### 8.8.1 Aux power cable installation

**Eight is the maximum number of aux power cables that can be plugged in or used with this model.**

The extra power is supplied directly from the power supply backplane (512 board) and there are 8 available power connections / ports in which the auxiliary power cables are plugged in, see photo below.

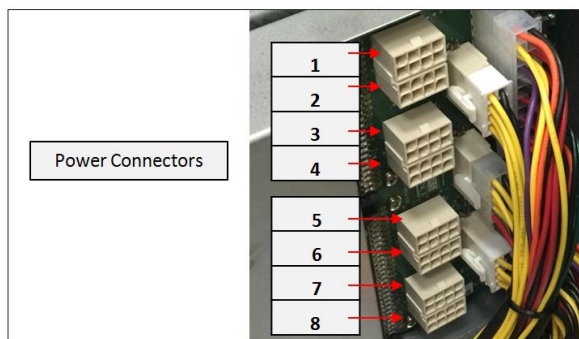
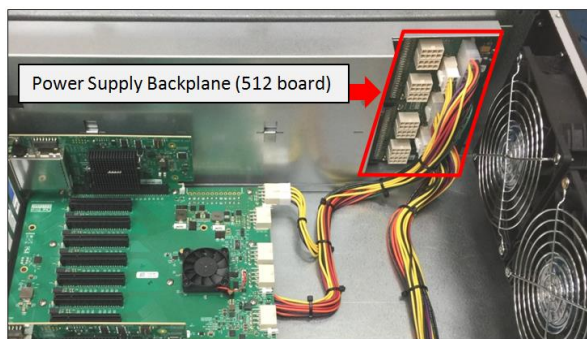

The power connection on the expansion backplane (452 board) are not being used, do not plug in any aux power cables on this connection. Make sure to use the ports / connections on the power supply backplane for the aux power cables, see photos below.

Connect aux power cables here ✓

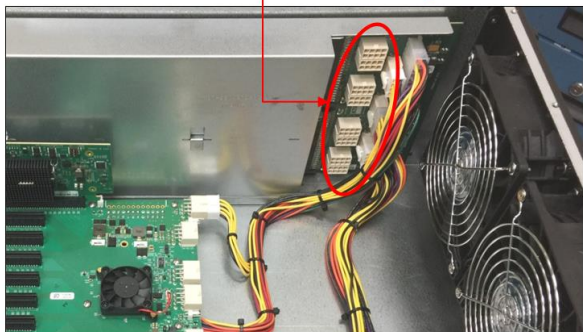

Do not connect aux power cables here ✗

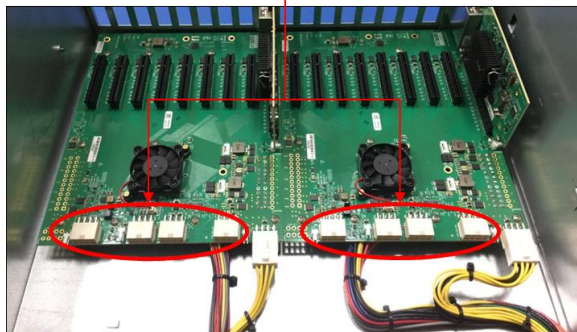

To plug in or connect the 6+2 pin cable to the power supply backplane, use the “Y” end of the cable, see photos below.

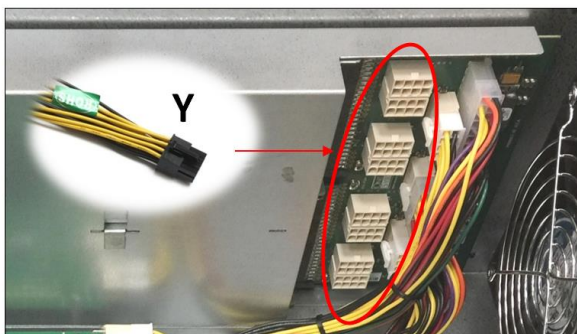
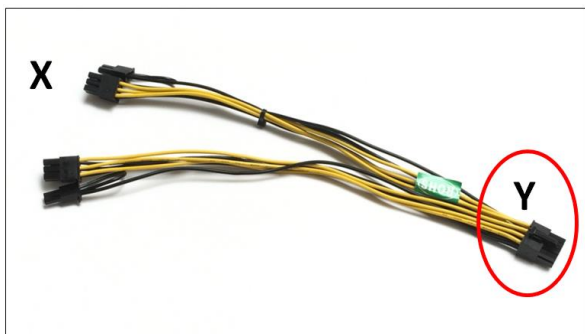

To plug in or connect the 8-pin cable, you can use either X or Y end of the cable, see photos below.

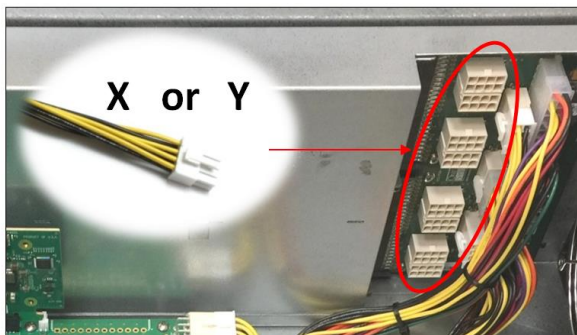

Ensure the cable is fully seated and secured.

There are eight available 8 ports / connections on the power supply backplane in which you can plug in the aux power cables. You can only use the OSS supplied 8-pin and 6+2 pin aux power cables ( 290-010-037-RC-01/02, 290-010-013-RC and 290-010-036-RC).



**NOTE**

Route cables away from FANs. For safety and proper airflow avoid blocking the fans.



### 8.8.2 Pinouts

PSU board aux port pinouts

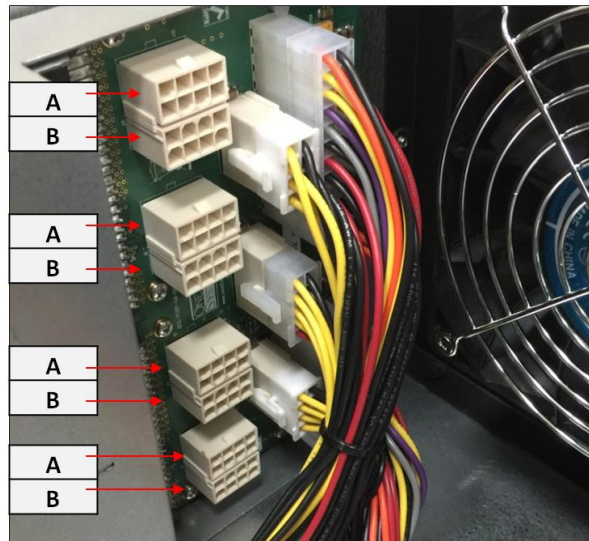
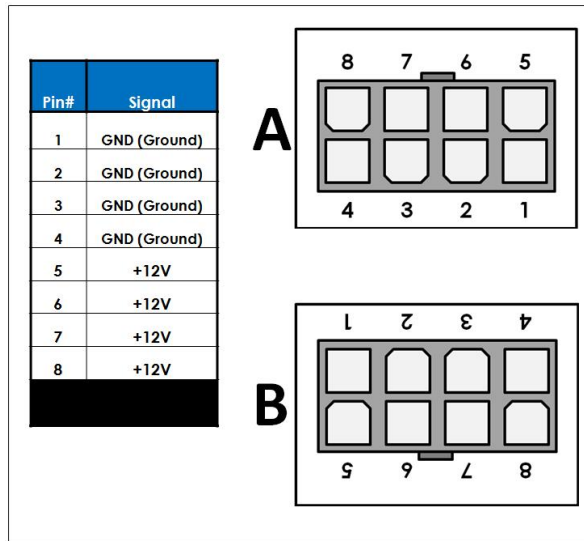

6+2-pin aux power cable and pinouts

Figure A1

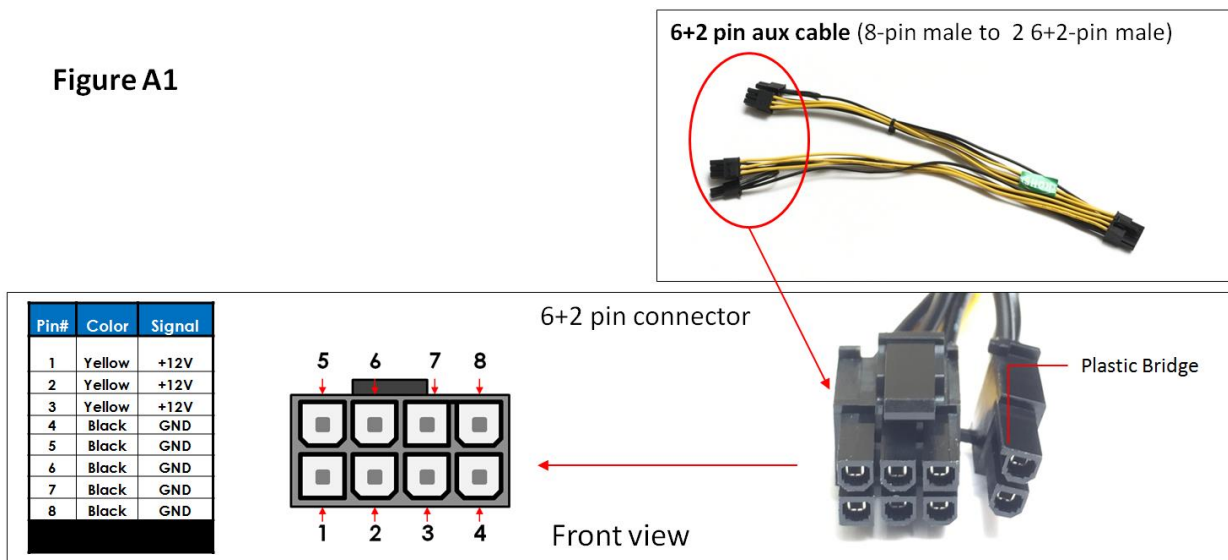
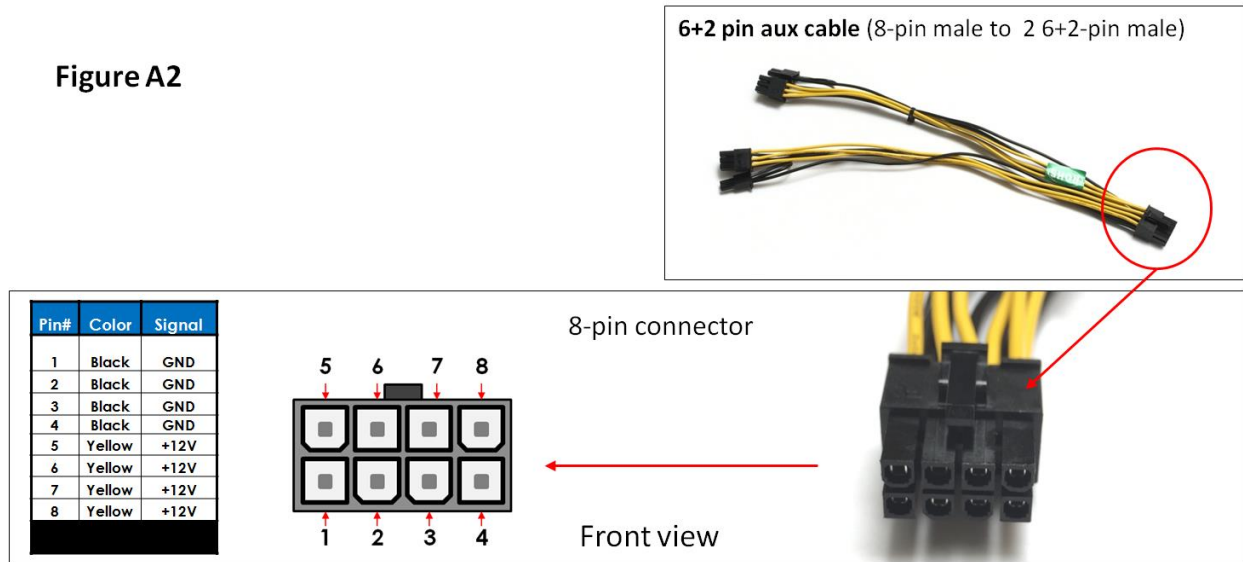

Figure A2



8-pin aux power cable and pinouts

Figure B1

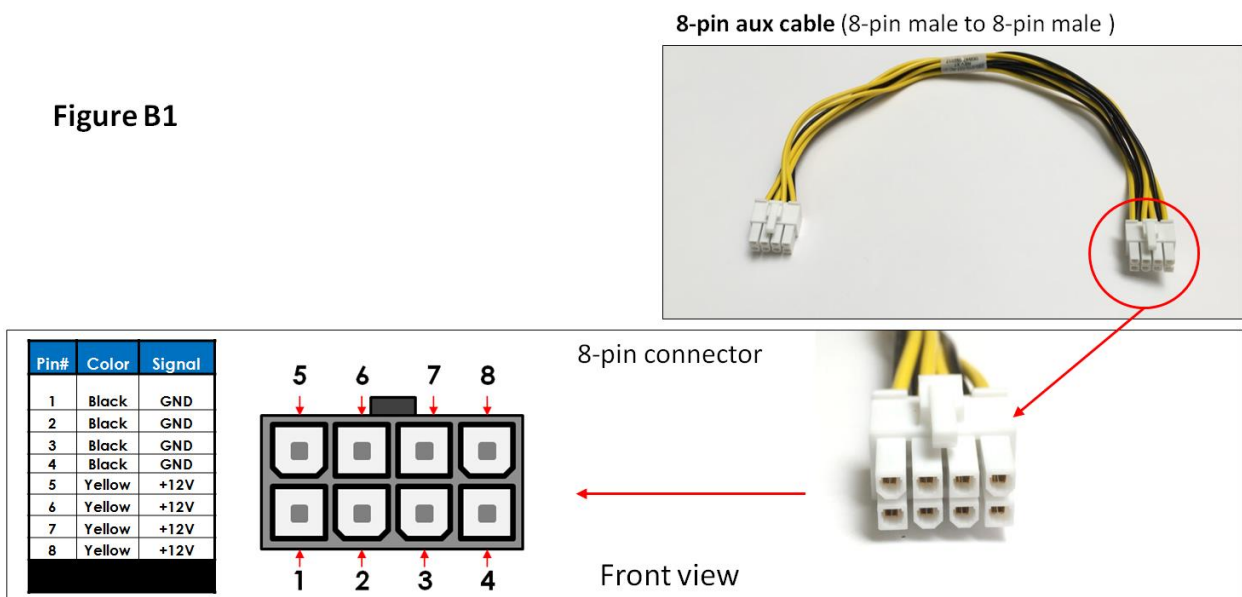
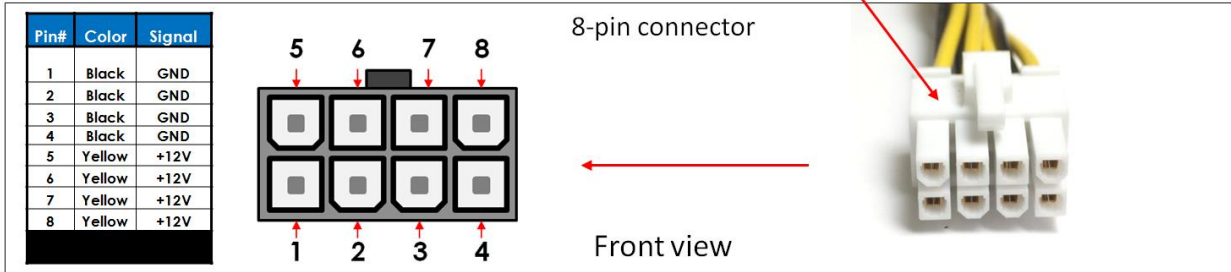
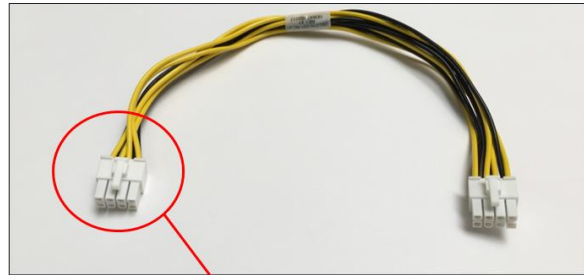

Figure B2

8-pin aux cable (8-pin male to 8-pin male )



### 8.8.3 Using the Auxiliary Power Cable

When using a PCIe card such as an FPGA card or GPU card that requires additional power you would need the aux power cables. Depending on the power requirement of your PCIe card, it will have a different built-in aux power port in which you attach the aux power cable.

A PCIe slot only provides 75 watts of power, there is not enough to meet the power requirement for a high-end with power consumption of over 125Watts or more for example. A direct connection to the power supply is needed to obtain additional power. This can be done by using the 6+ 2 pin or 8 pin auxiliary power cable. The below photos represent how the 6+2 pin connector and 8 pin aux power cables are attached to the PCIe card or GPU card.

The photo below is an example of a PCIe card or GPU card that has two 6-pin power connectors. You need two 6+2-pin aux cables to provide extra power.



The photos below are example of a PCIe card or GPU card that has a 6pin power connector. You need one 6+2pin aux cable to provide extra power.





FPGA card



The photo below is an example of a PCIe card that has an 8pin power connector. You need one 8-pin aux cable to provide extra power.



Example below, when using a GPU card that has a maximum power consumption of 300 Watt. It has an 8-pin and 6-pin power connectors.

Number of Pins	Watt
6 pin connector	provides 75 Watts
8 pin connector	provides 150 Watts

To provide additional power, you need two 6+2pin cable connectors, see Figure A.

Note: 300 Watt power needed = 75 Watt from PCIe slot + 75 Watt from 6-pin + 150 Watt from 8-pin.

The photo below is example of a PCIe card that has an 8pin and 6pin power connectors. To provide additional power, you need 6+2 pin power cables.



NOTE: We do not provide different aux power cables (i.e. 8pin to 4pin Molex) other than what we offer. If your PCIe card requires a different power adapter or aux power cable, you would have to buy it from other electronic stores.

## 8.9 Power Consumption

The 4u Value expansion unit draws a max. of 262 Watts (3 Fans + 2 Backplanes + 2 Interface boards) of power without any boards / cards installed.

### 8.8.1 Power consumption breakdown per hardware

Item	Hardware	Power Consumption
1	Target Cards	15 Watt per card
2	Fans	44.4 Watt per fan
3	Backplane	50 Watt (max); 23 Watt (min) per board

- Three Fans: 132 Watts
- Two Target cards: 30 Watt
- Two 452 boards: 100 Watts (max); 46 Watts (min)

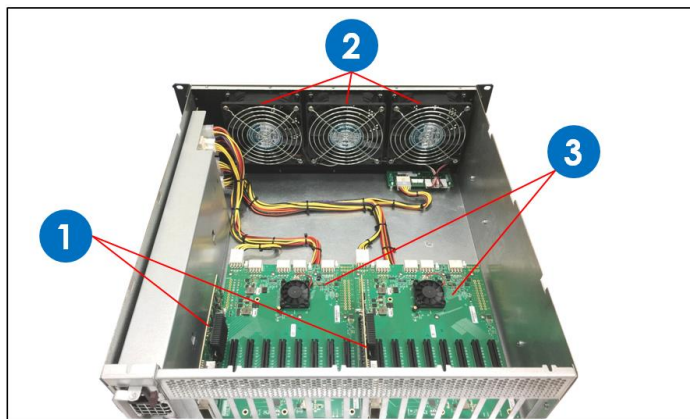

Item#	Description
1	Target Cards / Interface cards
2	Fans
3	Backplanes / Expansion Boards

## 9 Fan Controller

An optional fan PWM controller is available. Customer can purchase the configuration with the fan controller installed.



If you require the fan controller upgrade you need to contact our Sales Team ([sales@onestopsystems.com](mailto:sales@onestopsystems.com)).

- The upgrade can only be done in house (at OSS manufacturing plant).
- You have to send the unit back to One Stop Systems.

The upgrade involves the following:

1. Replacing the three existing fans (with 4-wire fan)
2. Connecting new wires
3. Setting up the Dip switches on the fan controller.
4. Drilling holes beneath the enclosure for mounting the PWM controller device.

Parts required: You need to order a new set of 4-wire fan (qty 3) and 1 PWM controller. Contact our Sales team for details.

The photos below are an example of two units: one unit with fan controller installed and one without the fan controller.

Without fan controller

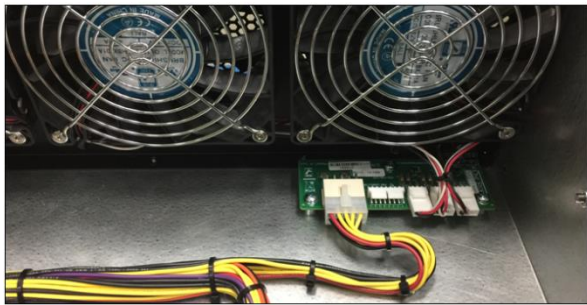

With fan controller

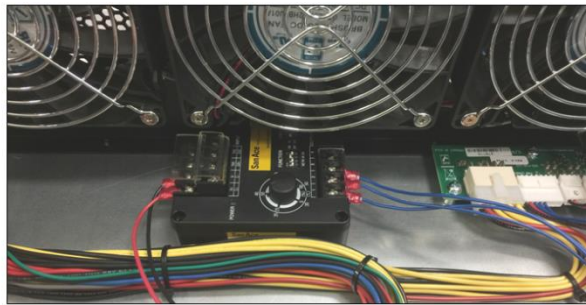

The 4u 8-slot Value Expansion chassis is designed to work with all types of PCI Express cards. Some PCI Express cards produce substantial heat and must be cooled properly to eliminate over heating problem. There are three fans located at the front of the enclosure to provide cooling required for the hottest PCI Express cards. As safety measure, by default the OSS provides 4u 8-slot Value expansion chassis with the fans functioning at full speed to prevent high-heat generating PCIe cards from over-heating

If noise is a concern, we provide an optional fan PWM Controller to help alleviate fan noise in situations when a low heat producing card is installed in the expansion unit. You can manage the velocity or speed of the fan by adjusting the "Adjustment Knob" to the desired percentage. When the PWM percentage is at 100%, the fan spins at maximum speed. When the PWM cycle is at 0%, the fans are stopped.

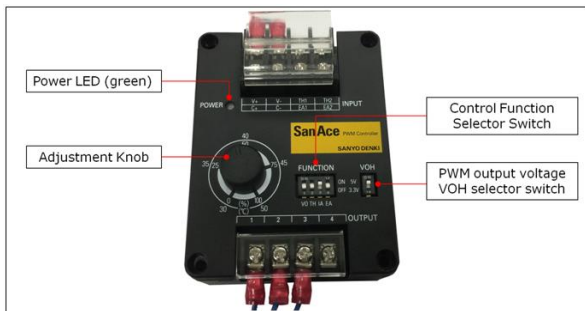

**Adjustment knob:**

- Primary function: Adjusting the speed of the fan. 100%= max speed; 0%= fan is stopped.
- Turn the knob counter-clockwise, reduces the fan speed. Turn the knob clockwise, increases the fan speed.

**Control Function Selector Switch:**

- Correct settings to operate the PWM Controller: 1(VO)=OFF , 2(TH)=OFF, 3(IA)=ON, 4(EA)=OFF

The PWM Controller in this setup can be operated in internal adjustment function (IA) only. This is why the IA is ON and the others are OFF. In the IA mode the adjustment shows the percentage duty cycle of the PWM (0%-to-100%). The 30-50 scale is only for TH and EA modes and are not being utilized in this configuration.

VO: Voltage control	TH: Thermistor control	IA: Internal adjustment control	EA: External adjustment control
---------------------	------------------------	---------------------------------	---------------------------------

**PWM output voltage VOH selector switch:**

- The default setting for VOH is 5v. The 5V level needs to be set for the fan to have the correct maximum voltage.

**Power LED Green:**

- When PWM Controller is ON, the LED will be illuminated as solid GREEN.

### 9.1 4-wire Fan vs. 3-wire Fan

In order for the PWM controller to operate properly you need to have a 4-wire fan. To find out whether you have a 3-wire fan or 4-wire fan, locate the LED/FAN Power board in the expansion chassis and see if all three fan power connectors have 3 or 4 wires.

The picture below shows a 3-wire fan. Each fan power connector has 3 wires (white, red and black). You cannot use the 3-wire fan with the PWM controller, you must replace it with a 4-wire fan.

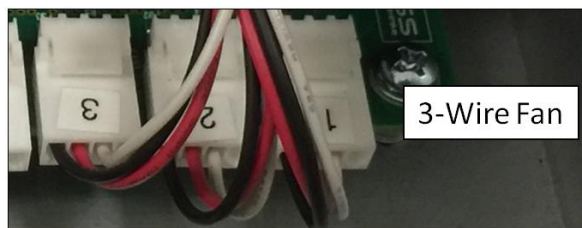

**IMPORTANT**

PWM controller and 4-wire fan are not field-replaceable. The entire unit needs to be sent back One Stop Systems repair facility.

## 9.2 Specifications

Item	Specifications	Remarks
Model no.	9PC8666X-S001	
Size [mm]	86 (H) × 66 (W) × 38 (D)	
Rated voltage [VDC]	12, 24, and 48	
Power consumption [W]	0.2 W	
Operating voltage range [VDC]	7 to 60 VDC	
PWM signal output	High-level voltage (VOH)	3.3 V or 5 V
	Low-level voltage (VOL)	0.4 V or lower
	PWM frequency	
Operating temperature [°C]	-20 to +70°C,	Non-condensing
Storage temperature range	-30 to 70°C	Non-condensing
Humidity (Operating and Storage)	20 to 85% RH	Non-condensing
	25 kHz	
Output PWM signal	VOH (high level voltage): 3.3 or 5 VDC (selectable). Frequency: 25 kHz	
Material	Case: Plastics	
Mass	Approx 110 g	
Insulation resistance	10 MΩ or higher using a 500 VDC insulation resistance tester.	Between the power supply input terminal and case
Dielectric strength	500 VAC (50/60 Hz) for 1 minute	Between power supply input terminal and case

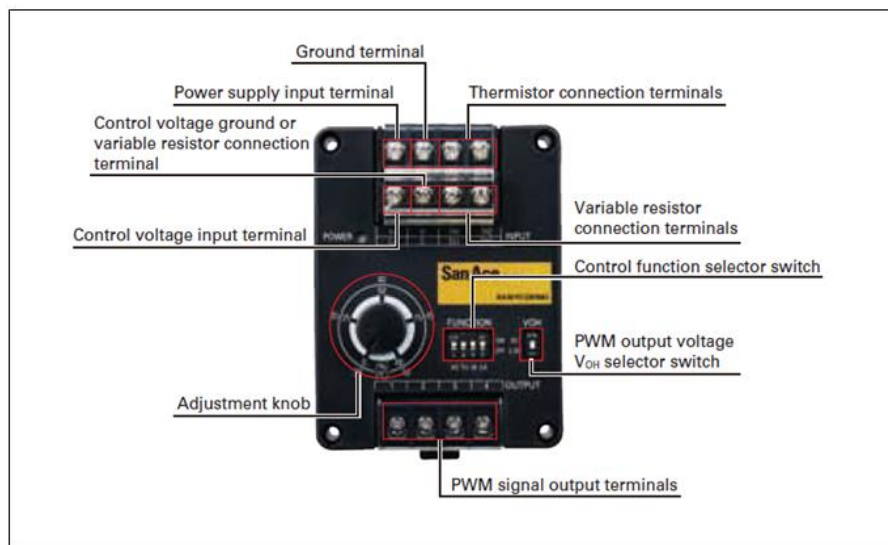



# 10 Troubleshooting

## 10.1 Locating the Problem

If you are having trouble with the One Stop Systems expansion system, first verify that all cards and cables are seated properly. Be sure you followed the instructions in earlier sections of this Service Manual. Always remember to power **On** and **Off** correctly when rechecking your installation. If you are still having problems, try these troubleshooting steps:

- My Computer Can't Find the PCIe Expansion System
- My PCIe Card Doesn't Work
- My system hangs beyond a certain number of add-in cards

### Windows

The 4u Value 8-slot Expansion System is correctly displayed as a **"PCIe Express standard Downstream Switch Port"** in Windows Device Manager, see photo below.

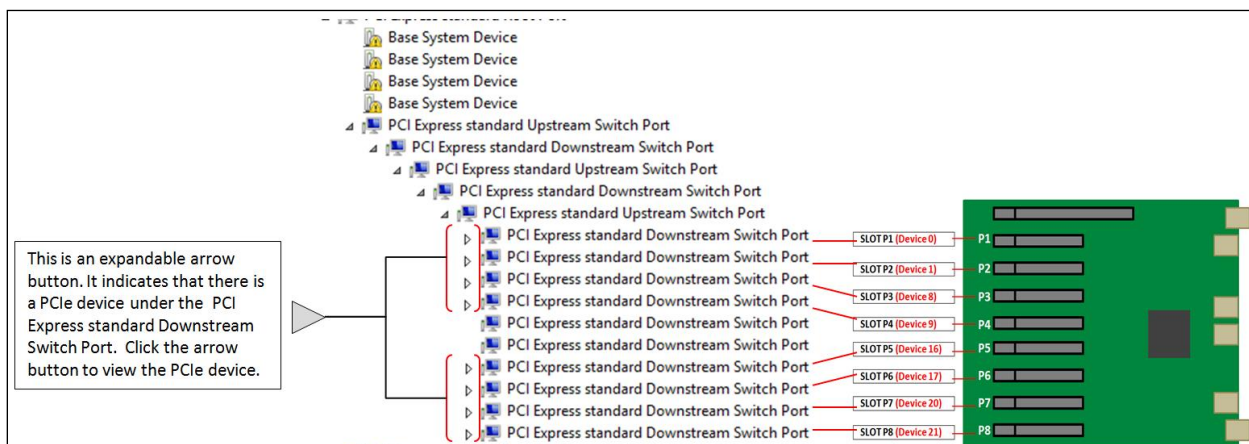

### Linux

In Linux, when connected and functioning correctly, this expansion unit will be displayed as follow, see photo below.

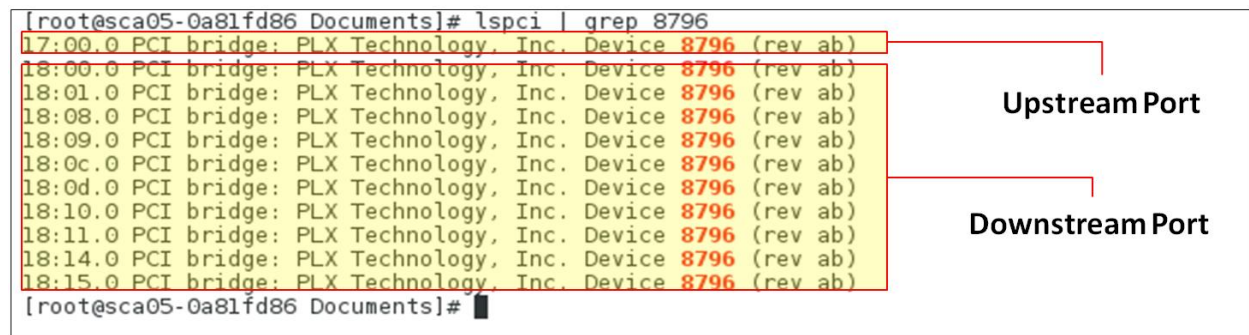

In Mac, when connected and functioning correctly (with PCIe cards installed) it should look like the photo below.

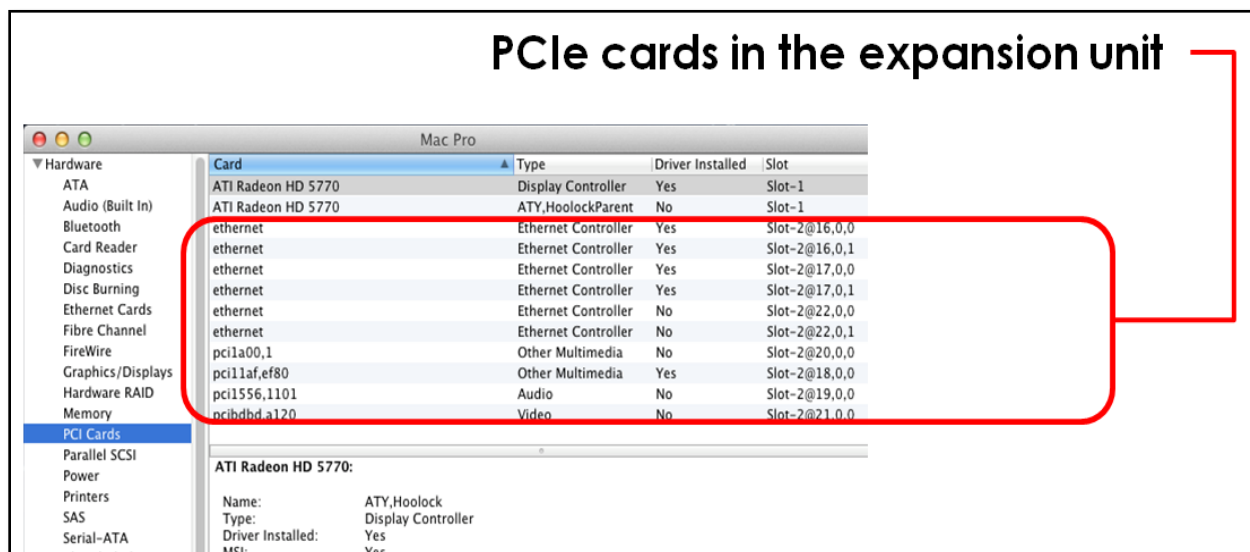

If this is not what you see when you verify your installation, the following troubleshooting steps may help you locate and resolve your installation issues without having to call Technical Support.

## 10.2 My Computer Cannot Find the PCIe Expansion System

If the expansion system is not being detected or recognized by the computer operating system (via Windows Device Manager, Linux -vtt output, or Apple System Profiler ) do the following

1. You will need to turn off your computer (and the expansion unit) and then reseat all link cables to ensure you have everything connected correctly
2. Verify that the required LEDs on the back of the Target and Host card are lit as explained in the [Chassis Linkup](#) section above. This is the most important LED indicators (CBL and EDG) that indicate a proper connection. All LINK LEDs on the host and target cards should be solid green and slot LINK LEDs should be illuminated (depending on Gen speed of the card)..
3. Verify the Target card in the correct designated slot and the Host card are properly inserted into the host computer x 16 slot. Make sure the SW1 Dipswitch settings on both interface cards are set correctly.
  - Try moving the Host card to a different PCIe slot (if a slot is available)
  - Try another host computer.
  - If the expansion system is still not visible after trying all of the above steps, try replacing the Link cables, and both interface cards.
  - If you are still having problem, you may need to send your unit for service.

### 10.3 My Computer Hangs During Power Up

If your computer “hangs” while being turned on and you cannot even start, follow the following steps to try to fix this problem:

1. Shut off the computer (first) and then the One Stop Systems expansion system and verify that all cards and cables are connected and seated correctly.
2. If it still hangs and you have added one or more cards in addition to several PCIe cards, ensure that you have not exceeded the power capabilities of the expansion system’s power supply. You can verify the capacity of your power supply by checking the label on the power supply. If you are not certain about the power consumption of your peripherals, it is best to remove them one by one (starting with those you suspect of being most “power hungry”) until the system powers up.
3. If you have removed all 3<sup>rd</sup> Party PCIe cards from the One Stop Systems chassis and it still hangs, try the following:
  - a. Remove the One Stop Systems Cle expansion host card from the computer and try booting up without the One Stop Systems expansion system attached.
  - b. If it boots up OK without<sup>th</sup> One Stop Systems expansion system attached, call One Stop Systems Technical Support.
  - c. If it still hangs, the problem is in the computer and not with the One Stop Systems expansion system or the 3<sup>rd</sup> Party PCIe cards.
  - d. If it booted up OK without any 3<sup>rd</sup> Party PCIe cards installed, try adding only one card and see if it boots up
  - e. If it boots up OK with one card, shut it down and swap the card. Repeat this until all cards have been tested.
  - f. If they all test OK, then add the card one at a time until you find the combination that does not work.
  - g. If you find that one of your card is bad card, replace it, you fixed it!

### 10.4 My PCIe Card Doesn’t Work

The following flowchart describes a general approach to resolve PCIe card issues:

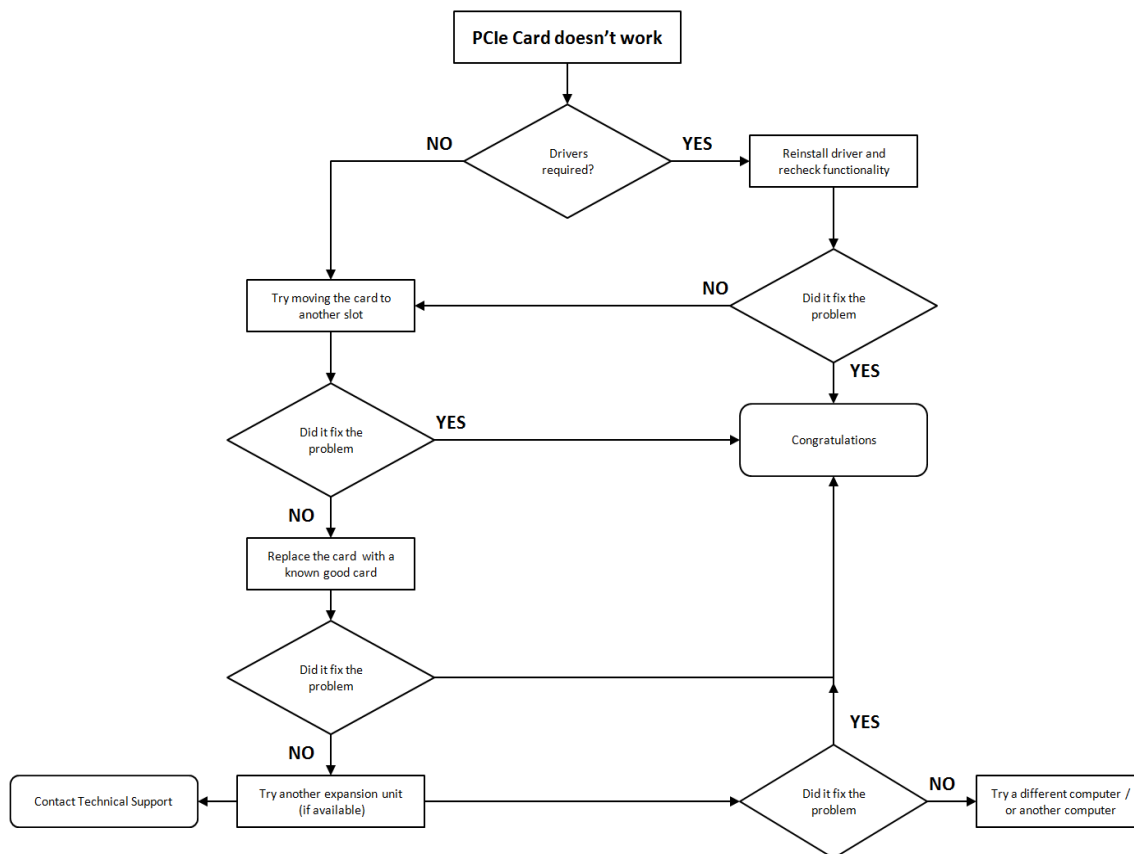

## 10.5 Support for 3<sup>rd</sup> Party PCIe Cards

One Stop Systems will provide reasonable technical support to with 3<sup>rd</sup> Party PCIe cards. However, if you have verified a successful installation of the One Stop Systems expansion system, but experience difficulty installing your 3<sup>rd</sup> Party PCIe cards, the card manufacturer should be able to provide the best support.



### IMPORTANT

The One Stop Systems expansion systems is designed to function exactly like your desktop computer. This means that you should follow the card maker’s instructions for installation on a Windows or Mac computer as if the expansion chassis WAS the desktop computer. When correctly installed, there is no difference to the operating system, removable cards, or most software.

### Windows Error Codes

If you are having a problem with one of your devices, and the Device status box shows a Windows Error Code, refer to the following list of error codes for guidance. These Windows error codes would help in troubleshooting and isolating the problem.

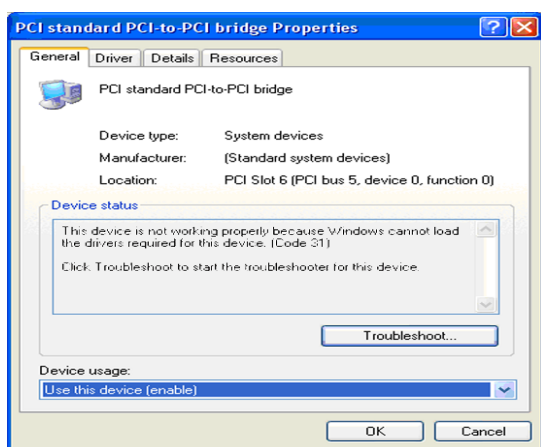

Error Code	Description/Action
10	<b>This code indicates that there is a problem with the 3<sup>rd</sup> Party PCIe Card driver.</b> If necessary, contact the card’s manufacturer for updated software drivers. If all else fails, contact One Stop Systems Technical Support for further assistance.
28	The driver for the PCIe card is not installed on your system. Reinstall the card driver following the manufacturer’s instructions. If that fails to fix the problem, call the card manufacturer for new drivers.
1	The PCIe host card or expansion chassis are not working correctly. Reinstall the PCIe host card into the computer’s slot and recheck all cable connections. If the error code remains, try another PCIe slot. If the error persists, call One Stop Systems Technical Support.
12	<b>On the Bridge:</b> If you receive error code 12 on the first PCI to PCI Bridge, call One Stop Systems Technical Support.  <b>On the Card:</b> This usually means the memory, I/O, or prefetch is more than has been allocated. Call One Stop Systems Technical Support

When your PCIe device or card is showing up with error, we highly recommend that you contact the vendor or manufacturer of the PCIe card for technical assistances.

Any PCI or PCI Express expansion scheme requires the cooperation of the computer system's BIOS in order to operate properly, regardless of the platform (PC/Laptop/Server) or operating system (MS Windows/MAC OS/LINUX etc.)

The BIOS hosts the first and the most fundamental code (firmware) that a computer executes upon boot-up. It is then that each PCI/PCIe add-in card (be it located on the host system or on One Stop Systems expansions chassis) is allocated Input/output memory space for proper operation.

By installing multiple add-in cards in one chassis or chaining multiple One Stop Systems chassis, we are requesting more and more resources from the BIOS and thus must make sure we pre-allocate them sufficiently.

It is therefore imperative that our computing platform allocates **at least 32KB** of I/O memory space to allow multiple add in cards to operate properly. This setting may be editable or preset by your BIOS (or computer) vendor. If you are having this problem it is recommended that you first update your system to the latest firmware provided by your vendor. Instruction on how to do that (as well as making a backup of your current BIOS firmware) should be provided by your computer vendor on their web site.

In case this property is editable, you computer vendor should also be able to tell you how to select at least 32KB using their BIOS interface.

## 10.6 PCIe card Memory Requirements

Always check the general system and hardware requirements as well as optimal CPU and GPU settings when using High Power GPUs. For example, you are using five XYZ brand Doublewide GPUs and each GPU requires 16GB of PCI Memory Address space. In order for these 5 XYZ GPUs to operate properly, a total of 80G of host system memory is needed during system boot. The system BIOS, during POST, will typically check for equivalent host system memory to be able to support PCI address space. The host computer should match or exceed the memory requirements of the total GPU PCI address space to achieve better performance and avoid problems that may cause the entire system to malfunction. Random crashes and other unexpected errors can occur if GPU memory requirements are not met or the system may not boot at all if the BIOS checks for and sees a mismatch on PCI address space and host system memory capacity. Check with GPU manufacturers for details on memory and systems requirements.



### NOTE

Increasing the size of the memory may not be enough for some systems, adjusting the settings in BIOS of the host system accordingly might be required (i.e. enable above 4G memory as well as increase MMIO space accordingly).

### Memory-Mapped I/O Greater than 4 GB:

All supported GPU cards require enablement of the BIOS setting that allows greater than 4 GB of memory-mapped I/O (MMIO).

**Standalone Server:** If the server is used in standalone mode, this BIOS setting is enabled by default: Advanced > PCI Configuration > Memory Mapped I/O Above 4 GB [Enabled]

Increasing the size of the memory may not be enough for some systems, adjusting the settings in BIOS of the host systems accordingly is required. (i.e. Enable "Above 4G Memory" and increase MMIO space)

# 11 Rackslide Installation

## 1. Remove Inner from the middle-outer rail

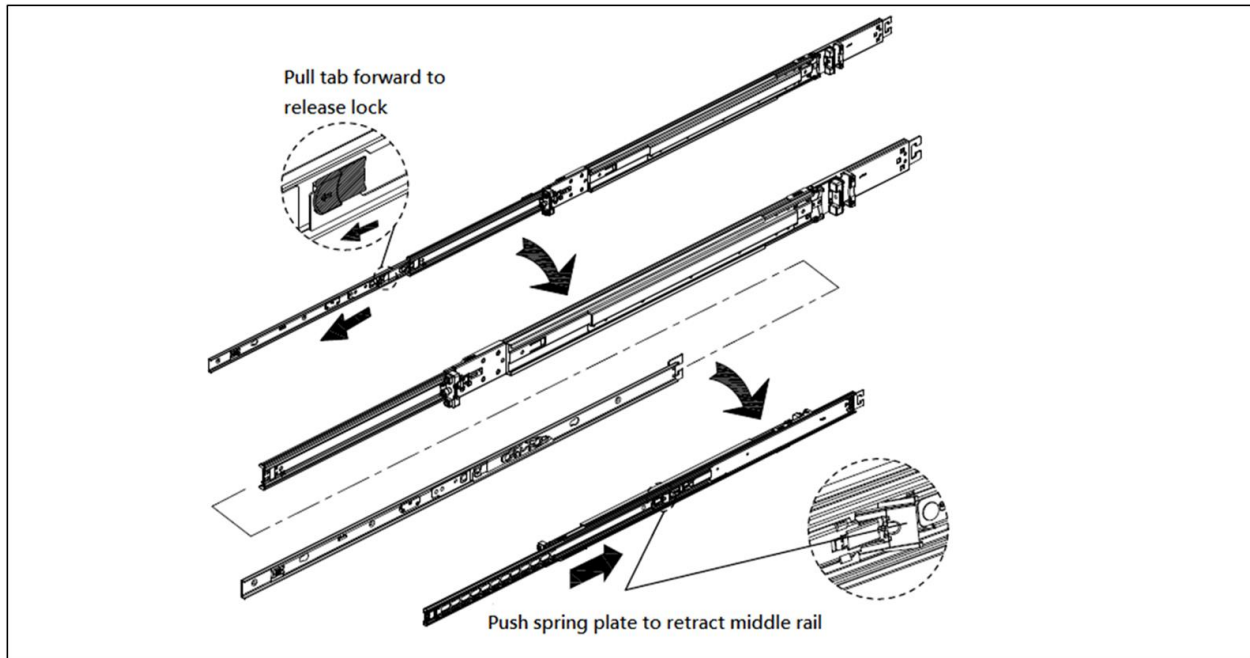

## 2. Install inner rail to both sides of the chassis

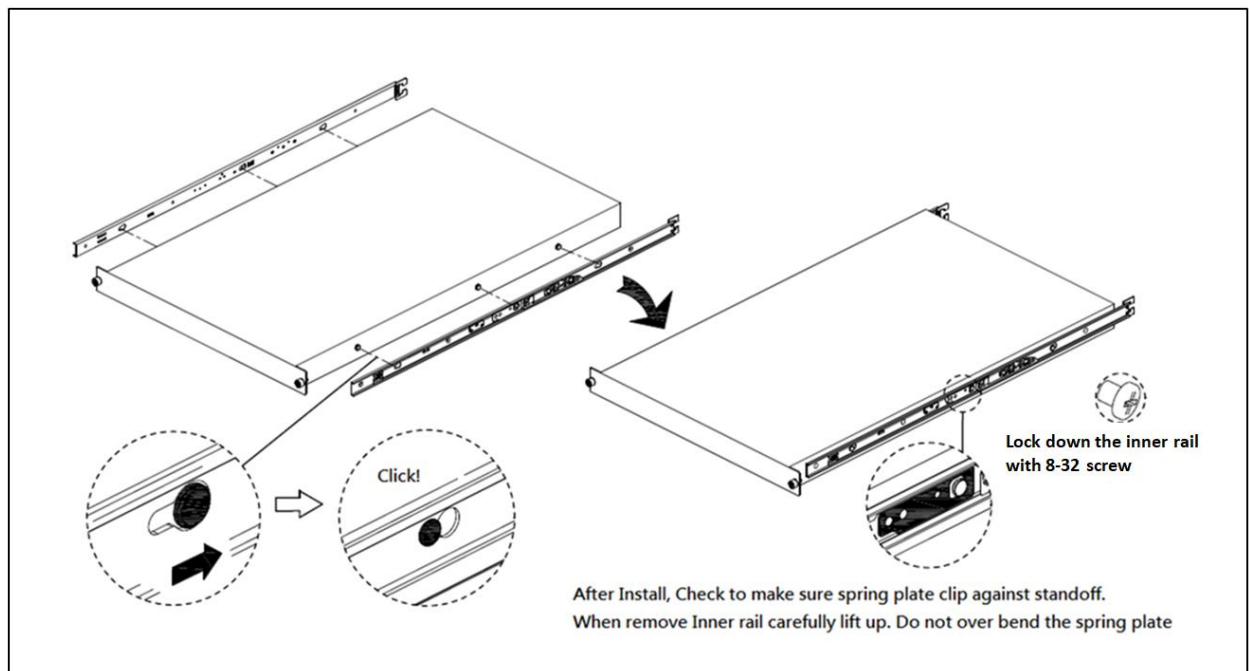

3. Install mid-outer rail onto rack post

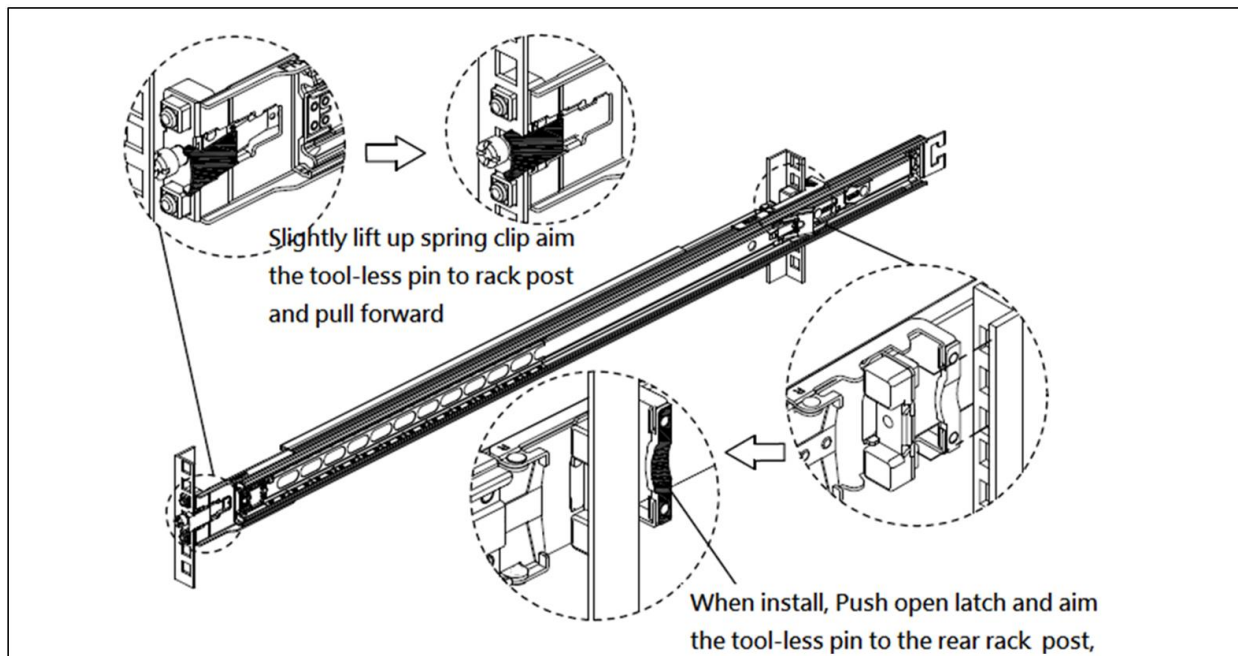

4. Insert chassis into middle-outer rail on the rack

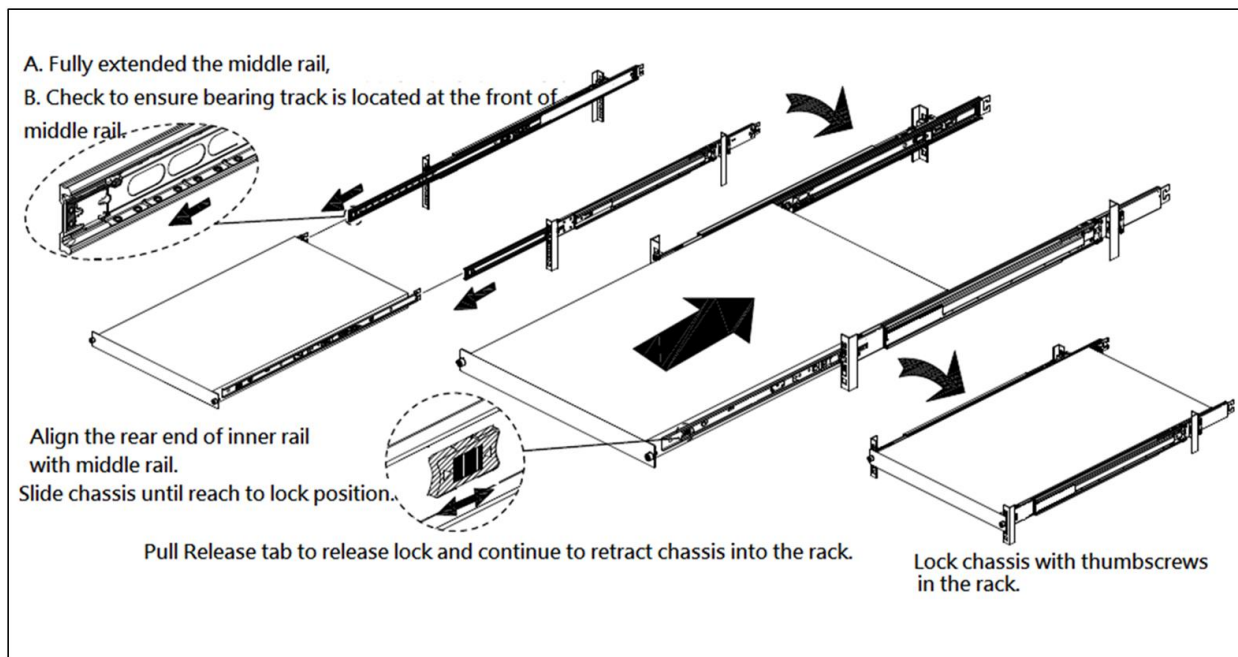

## 12 Enclosure Dimensions

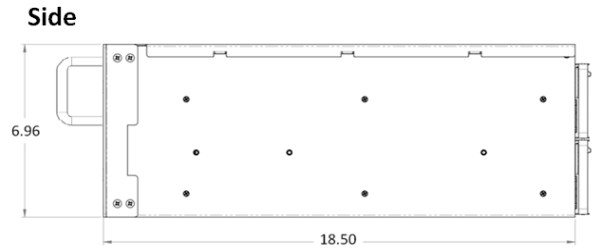
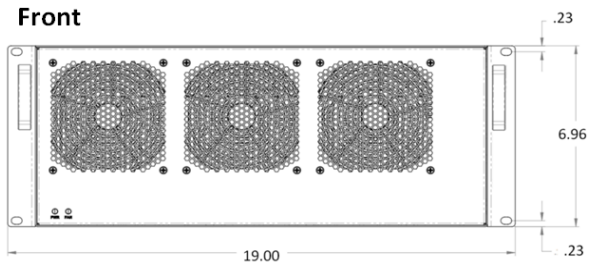
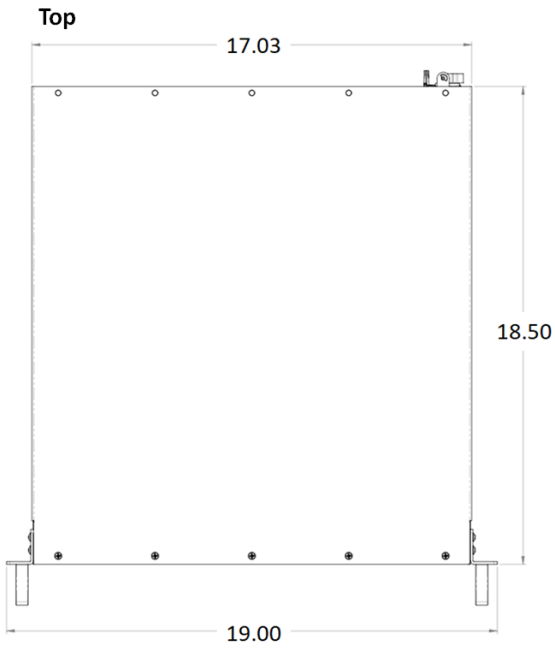



### 13 Rackslide Mounting Position

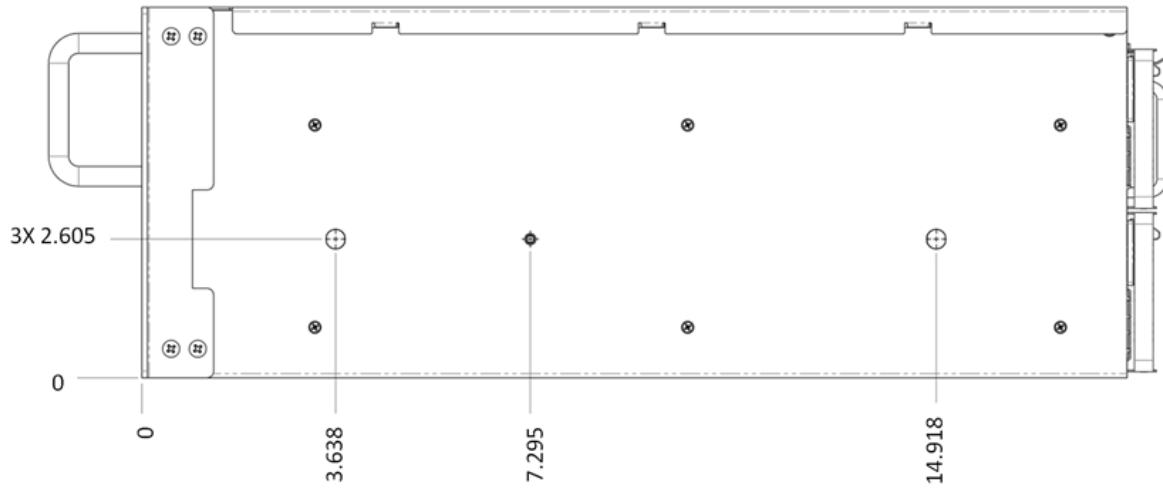

**BOTH SIDES IDENTICAL**

## 14 Frequently Asked Questions (FAQ)

1. Is there a switch on the HIB38X-16 CARD? if there is, what the vendor model and number?  
Answer: The HIB38 x16 card uses a Broadcom PEX8733.
2. Is the x16 Cable a 3.0 or 2.0 specification?  
Answer: Cable specification is 2.0 and it is 8GHz (Gen 3) times 16 bits for up to 128 Gbps.
3. What does it indicate when the front PWR & FAN LEDs come up as Amber or Orange?  
Answer: Is it an indication of faulty power and fan.
4. How many lanes are available on the PEX8796 switch on 452 backplane?  
Answer: On the 452 backplane, there are 8 x8 lanes (64 lanes), 16 for the target card and 16 unused lanes for a total of 96 lanes.
5. What does it signify when two solid green LEDs (CBK & EDG) on the back of Target and host cards come up?  
Answer: CBL shows the link status between the host card in the host computer and the target card in the expansion chassis. The EDGE shows: HOST card – connection between host card and host system. TARGET card – connection between the switch on the target card and the switch in the expansion chassis. Solid – Gen 3, Fast blink Gen 2, Slow blink Gen1.
6. What is the weight of the 4u Value chassis?  
Answer: The 4UV weights 30.0 lbs without the baseboard (452/457) or add-in cards
7. What is power consumption of HIB38-x16?  
Answer: 15W
8. Will the 4u Value chassis power UP automatically upon turning ON the host computer?  
Answer: Yes
9. Does the 4UV chassis need to be attached to a host (cable, host/target cards) to power ON?  
Answer: Yes
10. If the unit is running, can you pull one of the power supply module? Will cause a problem with the unit?  
Answer: That depends on the load inside the expansion chassis. If one supply is insufficient to provide power to all the add-in cards then it will fail.
11. I am assuming that there is a PCIE card that comes with the expansion box that has to be inserted in the host server. This card will connect the server to the expansion box via the PCIE cable. Is this correct?  
Answer: Yes, this is correct.
12. Is the PCIE card referred above called HIB38x-16 PCIE host target interface? (To me it looked like these are inserted in the slot on the expansion box backplanes. Without a card to be inserted in the host server - how would it connect to any server?)  
Answer: Host interface card. It comes with the expansion box. It is installed in a x16 PCIe slot in a host computer motherboard. The chassis is not limited to x16, It can also support a x4 and x8 Host Interface Board.
13. Can I connect two hosts (servers) to this system(expansion box)? Or do the cards have to be connected to the same server?  
Answer: Yes. You can connect the two host servers and YES you can connect to the same server.
14. You have two backplanes with 8 slots and each of those backplanes also have one PCIE switch. Is this the same PEX8733 switch referred to in the HIB38x-16 host target interface.  
Answer: Yes, the two backplanes have the same switch, it is Broadcom PEX8796 PCIe3 switch. The HIB38x-16 host / target interface cards have Broadcom PEX8733. OSS-452 has 8 x8 slots.

15. Is the backplane with 8 slots have the same PEX 8733 as the HIB38-x16?  
**Answer: No, they have 8796.**
  
16. If I am installing two backplanes, are the PCIe switches connected to each other (backplanes connected to each other) so that with one server connected to the expansion box with one cable I can access 16 PCIe card slots? Or is it one server to access all the 16 slots only with two PCIe cables?  
**Answer: The two backplanes are independent and there is not any connectivity between the two. You need two PCIe cables to access 16 slots.**
  
17. If the PEX switches in each backplane are connected to each other I need a configuration where in one state one host server acts as the root hub for all the 8 PCIe cards and if that host server fails the second server connected to the second backplane takes over as the root hub for all the 8 PCIe cards? Is this possible with this product?  
**Answer: Not applicable since there is not any connectivity between the two PCIe switches.**
  
18. Can I unplug the link cables while the expansion unit and the host computers are running?  
**Answer: It is not recommended to unplug or plug in the link cables (x16 cable) while the expansion unit and host computers are running as this can cause failure.**
  
19. Can I update my unit to have a fan control or PWM capability:  
**Answer: Yes, but you have to send the entire unit (as RMA) to OSS to perform the update (PWM capability).**
  
20. Can I buy aux power cables for my unit?  
**Answer: Yes, contact OSS Sales for more information.**

## 15 Contacting Technical Support

Our support department can be reached by fax at (858) 530-2733 or by phone at (858) 530-2511. Support is available Monday through Friday, 8:00 AM to 5:00 PM PT. When contacting One Stop Systems Technical Support, please be sure to include the following information:

- |                  |                                                  |
|------------------|--------------------------------------------------|
| 1) Name          | 7) Serial Number                                 |
| 2) Company Name  | 8) Computer Make                                 |
| 3) Phone Number  | 9) Computer Model                                |
| 4) Fax Number    | 10) Operating System and Version                 |
| 5) Email Address | 11) Make/Model of PCI cards in expansion chassis |
| 6) Model Number  | 12) Detailed description of the problem          |

You can also visit our web site at: [www.onestopsystems/support/](http://www.onestopsystems/support/)

For a quick response, use the Technical Support and RMA Request Form available in the Support Section of the website. Simply complete the form with all required information. Please make sure that your problem description is sufficiently detailed to help us understand your problem.

For example: Don't say "Won't boot up." Do say "Tried all the steps in the Troubleshooting Section and it still won't boot up."

For faster diagnosis of your problem, please run the two utility programs described in the following sections and include the diagnostic files they generate with your email.

## 16 Returning Merchandise to One Stop Systems

If factory service is required, you must contact OSS Service Representative to obtain a Return Merchandise Authorization (RMA) number. Put this number and your return address on the shipping label when you return the item(s) for service. **One Stop Systems will return any product that is not accompanied by an RMA number.** Please note that One Stop Systems WILL NOT accept COD packages, so be sure to return the product freight and duties-paid.

Ship the well-packaged product to the address below:

RMA # \_\_\_\_\_

One Stop Systems

2235 Enterprise Street, Suite#110 92029

USA

It is not required, though highly recommended, that you keep the packaging from the original shipment of your One Stop Systems product. However, if you return a product to One Stop Systems for warranty repair/ replacement or take advantage of the 30-day money back guarantee, you will need to package the product in a manner similar to the manner in which it was received from our plant. One Stop Systems cannot be responsible for any physical damage to the product or component pieces of the product (such as the host or expansion interfaces for the PCIe expansion chassis) that are damaged due to inadequate packing. Physical damage sustained in such a situation will be repaired at the owner's expense in accordance with Out of Warranty Procedures. Please, protect your investment, a bit more padding in a good box will go a long way to insuring the device is returned to use in the same condition you shipped it in. Please call for an RMA number first.

## 17 APPENDIX A Compliance

### FCC

NOTE: This equipment has been tested and found to comply with the limits for a Class A digital device, pursuant to part 15 of the FCC Rules. These limits are designed to provide reasonable protection against harmful interference when the equipment is operated in a commercial environment. This equipment generates, uses, and can radiate radio frequency energy and, if not installed and used in accordance with the instruction manual, may cause harmful interference to radio communications. Operation of this equipment in a residential area is likely to cause harmful interference in which case the service personnel will be required to correct the interference at his own expense.

This device complies with Part 15 of the FCC Rules. Operation is subject to the following two conditions: (1) this device may not cause harmful interference, and (2) this device must accept any interference received including interference that may cause undesired operation.

Changes or modifications not expressly approved by the party responsible for compliance could void the service personnel's authority to operate the equipment.



#### NOTE

The assembler of a personal computer system may be required to test the system and/or make necessary modifications if a system is found to cause harmful interferences or to be noncompliant with the appropriate standards for its intended use.

---

Industry Canada

This Class A digital apparatus complies with Canadian ICES-003. Cet appareil numérique de la classe A est conforme à la norme NMB-003 du Canada

### CE

The product(s) described in this manual complies with all applicable European Union (CE) directives. One Stop Systems will not retest or recertify systems or components that have been reconfigured by customers



**2235 Enterprise Street, Suite#110, Escondido CA 92029**

Toll-Free : +1(800)285-8900 US • Main: +1 (760) 745-9883 • Fax: +1 (760) 745-9824

**[www.onestopsystems.com](http://www.onestopsystems.com)**