

DURANGO 12V Heater – HF-100012

- 1 – Product description
- 2 – Operating principle
- 3 – Mounting recommendations
- 4 – Troubleshooting
- 3 – Safety instructions



1 – Product description

The DURANGO heater consists of a 12v DC permanent magnet motor, coil, plastic centrifugal wheel and housing. The plastic parts are impact resistant ABS.

The heater is a 2 speed unit, requiring connection of 3 wires and coolant supply input and output hoses. Each lateral side has an air inlet. The front has an air outlet with 2 louvers.

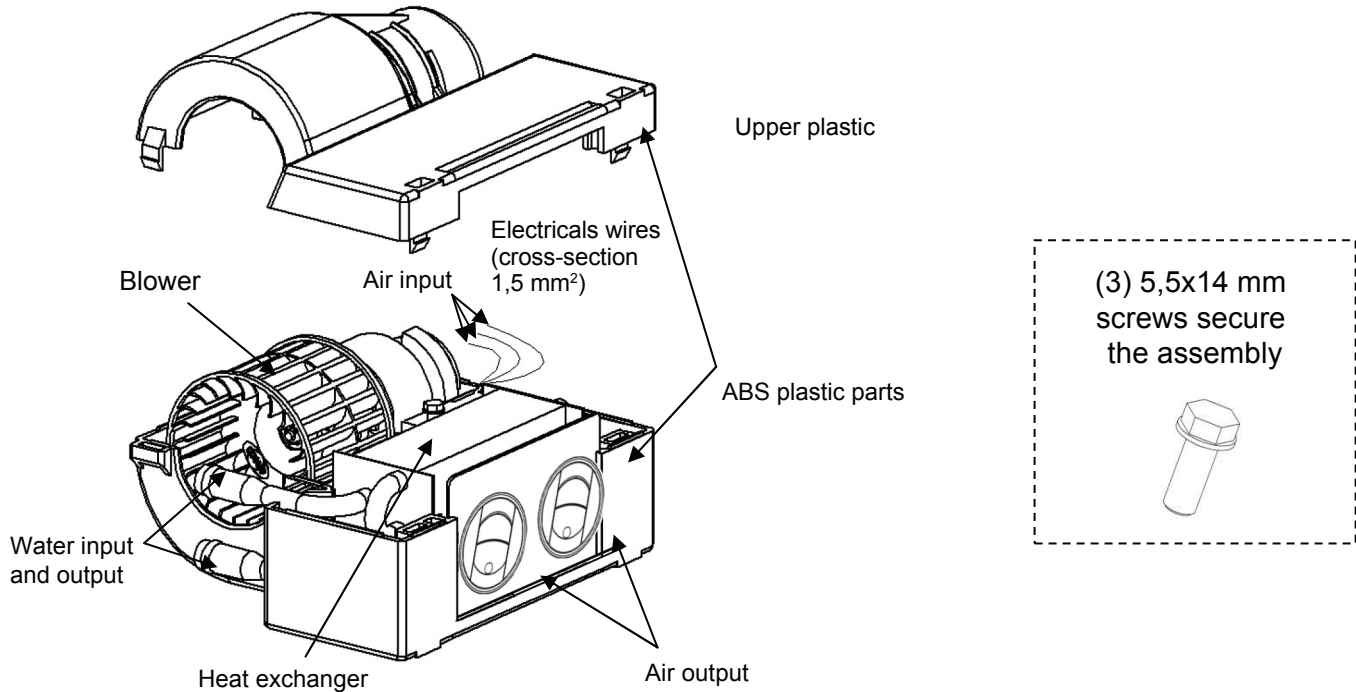

2 – Operating principle

Vehicle engine coolant, runs through the coil. At the same time, the blower unit blows fresh air through the heat exchanger, elevating the air temperature, which then exits through the outlet louvers.

Operating conditions:

Heater must be located to receive fresh air.

Operating temperature between -15°F and +178°F.

Cooling fluid must be antifreeze and anticorrosive for copper and aluminum. Use a cooling liquid officially recognized by automotive manufacturers.

Technical data:

The values are given for information purposes.

Voltage	Electrical power	Heating capacity	Nominal air flow	Weight
12 V	≈ 55 W	≈ 8,100 BTU/hr	72 CFM	2.64 lbs

Optimum heating capacity is reached with air inlet temperature of 0°C, nominal air flow of 0,5 m³/h, 50% ethylene glycol and water, and coolant inlet temperature of 100°C.

3 – Mounting recommendations

1

Secure the mounting bracket (supplied) to the bottom of the heater using 3 - #5 screws (5x14 mm) for plastic material (supplied). Recommended tightening torque is 12 in./lbs. Thickness of the mounting bracket: 3 mm Max. Blower motor axis should be in a horizontal position on the vehicle.

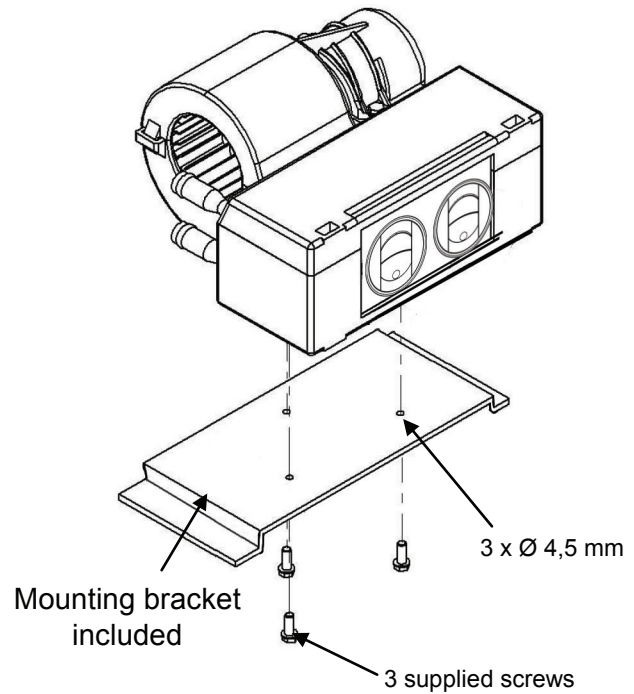
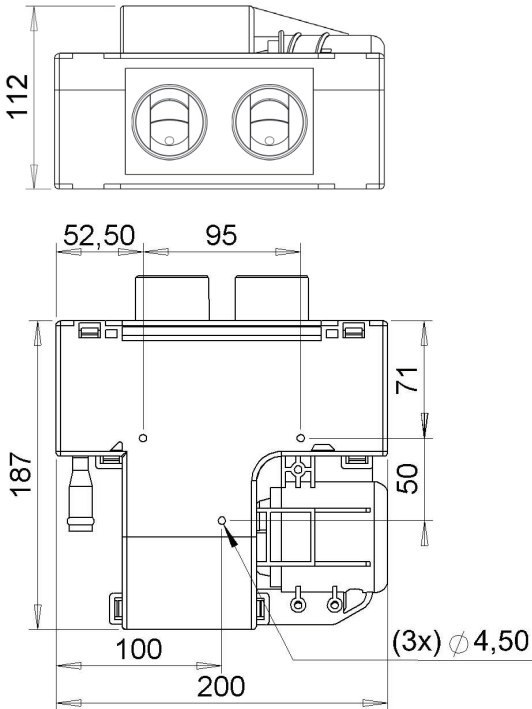

Do not drill into the heater case as it may cause damage to the internal components!

2

Connect 5/8" diameter heater hoses to heater inlet and outlet copper tubes using suitable hose clamps (hoses and hose clamps, not included). There is no preference for coolant flow direction.

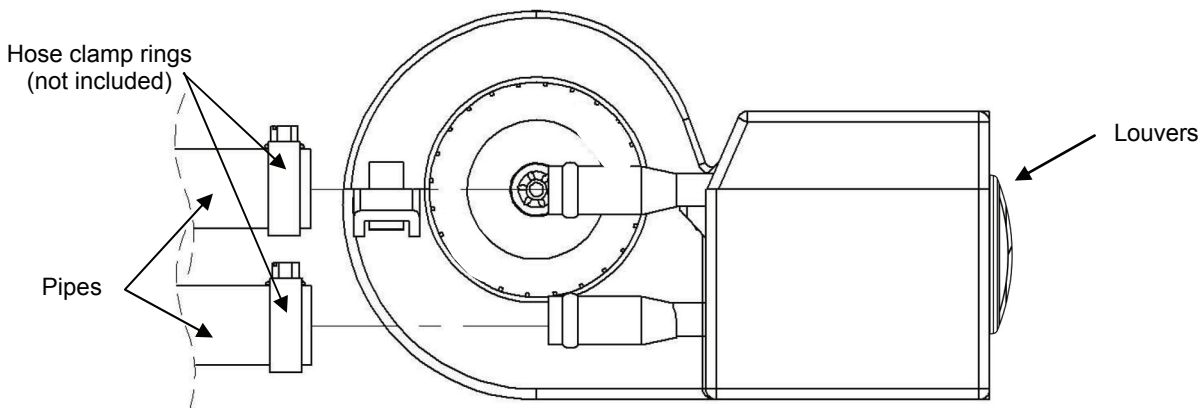

Inspect for coolant leaks

3 The heater electrical circuit should be 14-16 ga. wire per the circuit diagram.

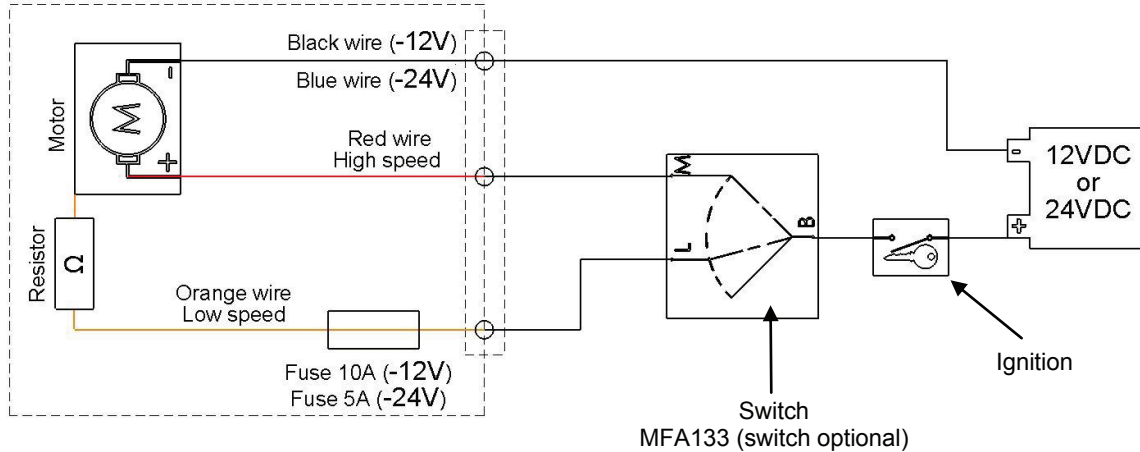

4 – Troubleshooting

Defect	Possible cause	Action
The blower does not work.	Defective fuse.	Ensure that the fuse is correctly installed and has the correct rating. Replace it if necessary. Always identify the cause before replacing the defective fuse.
	No power.	Switch On and/or connect the device to the battery. Make sure that electrical connections between the battery and the device are continuous. Read the vehicle operating instructions for more information.
	Electric cables are damaged or torn.	Contact your distributor.
	Blower is blocked.	Rectify cause of blockage, for example, remove an object immobilized in wheels. Otherwise contact your distributor.
	The blower motor is defective.	Contact your distributor.
	The device can't be stopped.	Internal short circuit in the device.
The heater works only at reduced power.	The voltage isn't suitable.	The voltage of the device and of the vehicle must be the same.
	The air outlet is closed or plugged.	Open the air vents or clear air outlet.
Air is not warmed.	Coolant still cold.	Wait until the engine reaches operating temperature.
	Water hoses are twisted or crushed.	Replace the water hoses if they are twisted or crushed.
Heating power is insufficient.	The airflow is too low.	Refer to the blowers defects.
	Air in heat exchanger.	Bleed the circuit.
	The heater is under sized.	Replace the device with a larger one. Contact your distributor.

The warranty doesn't cover products which have been disassembled!

5 – Safety Instructions

Please comply with the following instructions for your own safety:

- The product must be installed by a professional.
- The product must operate in an environment protected against liquid splashes (water...).
- The product must be used only for the purposes for which it has been designed. Product should never be used in an improper environment. Please refer to general sale conditions.
- Before using the product, please make sure that laws and regulations are strictly respected according to the country of use.



For safety reasons (fire hazard), the power supply of the product must be protected by a specifically dedicated fuse.

- The fuse rating is given only as an indication, please verify the specific fuse required for each application.
- Switch off electric power supply before working on the product.
- Be careful, while servicing the device or its connections, the radiator and the coolant can be hot and under pressure.
- Before any servicing, wait for the complete cooling of the device and its connections. Make sure that it is no longer under pressure. Use suitable I.P.E. (Individual protection equipments) such as gloves.
- Do not touch the heat exchanger and its connections when coolant is flowing through the heat exchanger.
- Do not introduce any object into the blower and the heater case.
- Do not place any object that may obstruct air inlets or air outlets.