



DIRECTION #695

- STEP #1.** Place the bar in position on top of the axle, dip up. Arm leading to the rear. On top of the axle toward the shoulders of the bar, place the locking device and plate which will now be between the axle and the bar. Over the bar and aligning with the plates, place the bracket. Pass the large U-bolt up from below the axle, through the holes in the plate and the bar bracket and start the nuts. Be sure that the U-bolt or other parts are between the brake line and the axle so as not to crush them. Pull the brake line away from the axle slightly if needed.
- STEP #2.** Place the D-shaped rubber bushing on the bar mid-section and slide it under the bar bracket. Adjust the position of the brackets and U-bolts about the axle so that they give best clearance to shocks, brake-line "T", rear end breather, etc. So that they hold the bar in most suitable position along the top part of the axle. The bolts and brackets need not be equally spaced along the axle on the two sides. Tighten the U-bolt nuts sufficiently to keep the assembly in position during installation.
- STEP #3.** Assemble end-link onto bar ends. Center bolt passes through: washer, rubber bushing, frame bracket (from inside bracket). Rubber bushing, washer, spacer, washer, rubber bushing, bar eye, rubber bushing, washer, and finish with the nut. This nut should only be tight enough to keep assembly snug.
- STEP #4.** Raise bar arms so that the frame bracket are against frame bottom. Mark through holes in the bracket for drilling. Be sure the truck is resting on its springs when doing this. Drill holes with a 5/16" drill bit, then bolt bracket up to the frame as shown and tighten.
- STEP #5.** Have someone bounce the rear of the car so that you can check the clearance throughout the suspension travel distance. Tighten the nuts on the axle U-bolts to 10 ft./lbs. Check to make sure they are holding securely. Test drive the car and accustom yourself to its new handling. As we cannot supervise your installation (or driving) we cannot be responsible for more than the cost of the kit.

HARDWARE:

2	RH 016 End-Links	2	RH 054 Brackets
2	RH 041 Brackets	2	RH 405 U-Bolts
4	RH 307 Lock-Nuts	4	RH 104 Washers
4	RH 031 Plates	4	RH 304 Lock-Nuts
2	RH 043 Brackets	4	RH 200 Bolts
2	RH 508 Bushings		

Warning: This equipment is engineered to operate throughout your vehicle's normal suspension travel distance. If the bottoming snubbers have been cut down, or if the vehicle has been raised and the snubbers have not been raised also, the vehicle suspension may travel through a much greater distance and that may damage the anti sway bar or its connections, as well as the shock absorbers, brake hoses, and other suspension parts.

DIRECTION 695

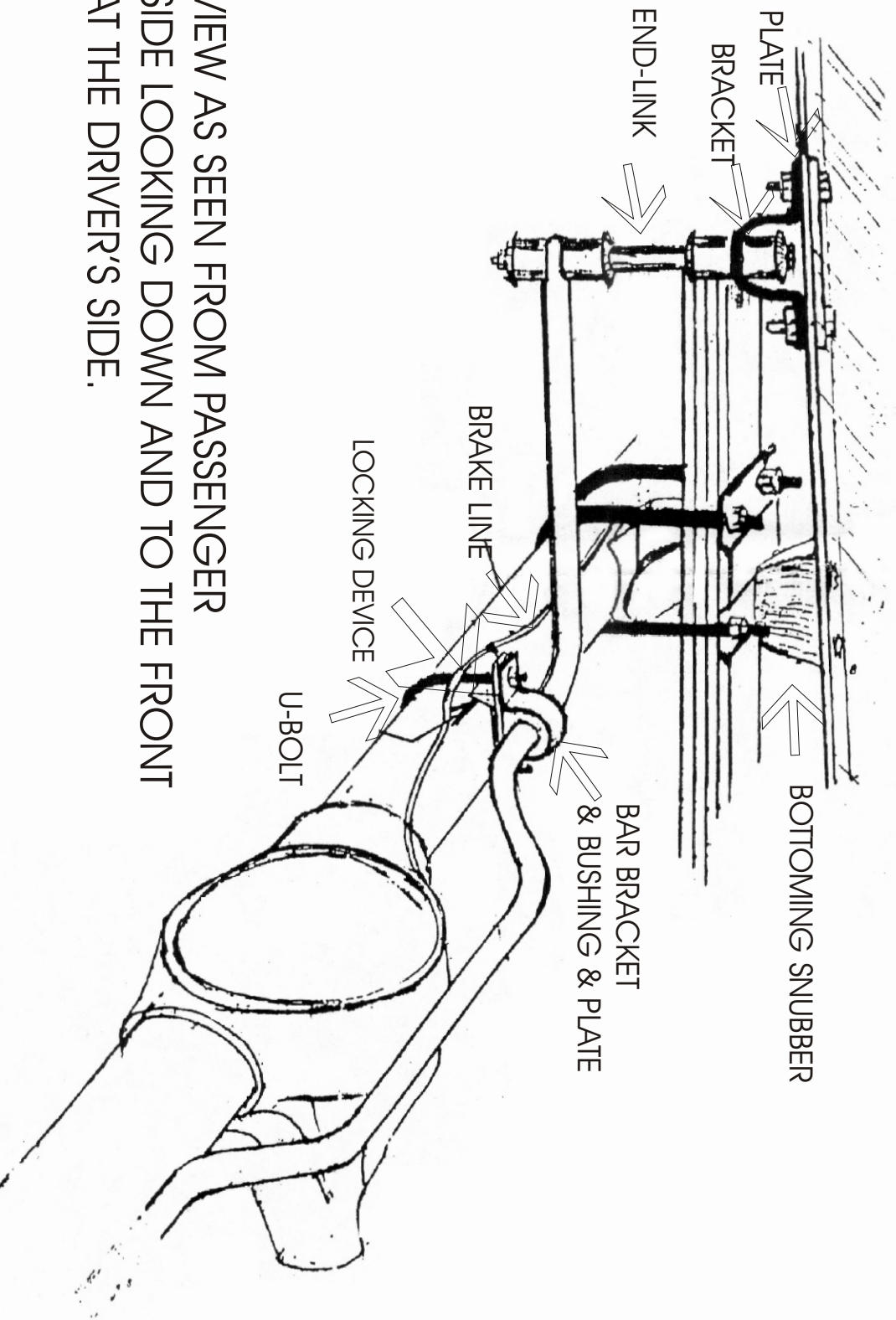

VIEW AS SEEN FROM PASSENGER
SIDE LOOKING DOWN AND TO THE FRONT
AT THE DRIVER'S SIDE.