



## **DIRECTIONS 347**

**STEP #1.** Slide the bar into position from one side so it passes just over the spare tire with the arms forward. Slide the mid-section bushing onto the bar.

**STEP #2.** Assemble the end-link on the bar eye as shown with the adaptor plate at the bottom. Tighten the lock-nuts just enough to keep the assembly snug.

**STEP #3.** Slide the plate with the two pressed in lock-nuts into the suspension assembly. Place the adaptor plate on top of the suspension link assembly. Run the 5/16" bolts through the adaptor plate, then through the existing holes in the suspension and into the plate containing the lock-nuts.

**STEP #4.** Position the frame bracket over the bar bushing and attach to the existing threaded holes via the bolts provided. (Very early models and some late models have no threaded holes in the frame. On these cars, use the square U-bolt provided. See the General Instructions.)

**STEP #5.** Check all fastenings for suitable tightness. Bounce the car to make sure that all parts clear throughout the suspension travel distance.

**STEP #6.** Road test the vehicle to accustom yourself to its new handling. As we cannot supervise your installation, or your driving, we cannot be held responsible for more than the cost of the kit. For best results this kit should be used in conjunction with our front bar kit.

### **HARDWARE:**

<b>2 RH 610W Bushings</b>	<b>4 RH 104 Washers</b>
<b>2 RH 046 Brackets</b>	<b>2 RH 015 End-Links</b>
<b>2 RH 610 Plates</b>	<b>2 RH 609 Plates</b>
<b>4 RH 200 Bolts</b>	<b>4 RH 304 Lock-Nuts</b>
<b>2 RH 402 U-Bolts</b>	<b>4 RH 218 Bolts</b>

# DIRECTION 347

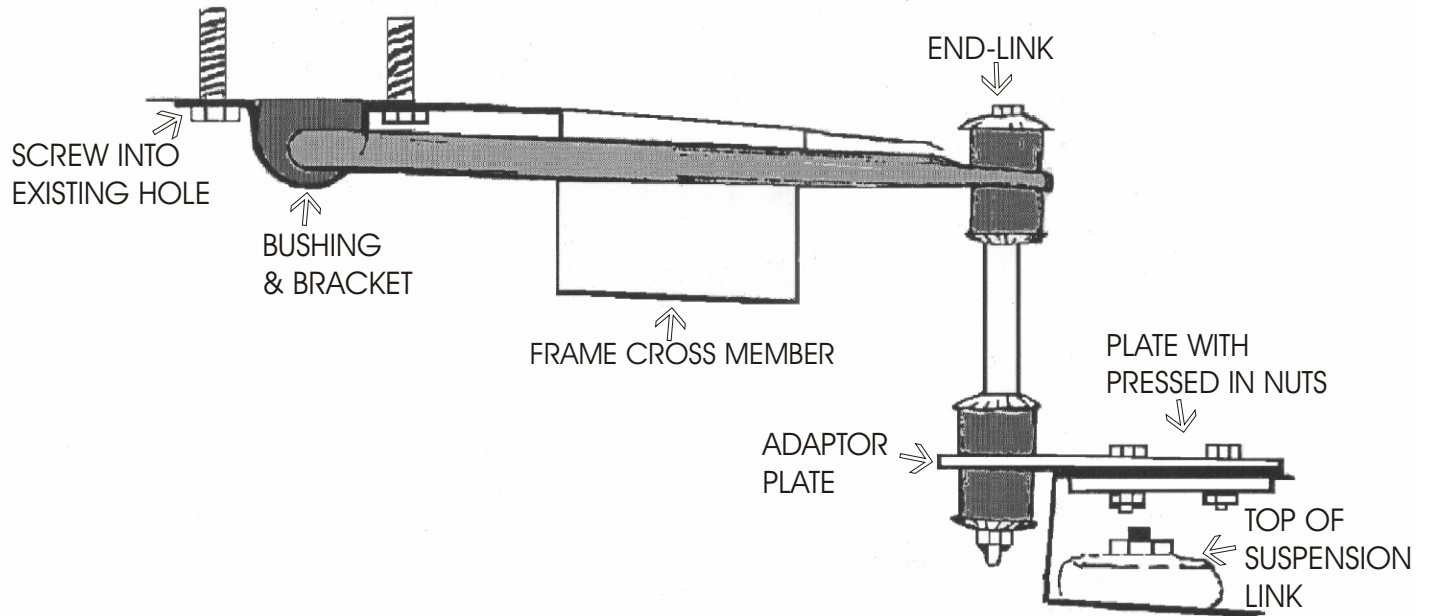

## HOW TO INSTALL A 402 U-BOLT

