



OEM 5TH WHEEL ADAPTER RAM (PUCK STYLE)

MODEL #48662

Since 1952

CAREFULLY READ THE FOLLOWING INSTALLATION INFORMATION.

Item no	Description	Included
1	Lock Support, Counter-Clockwise	2
2	Lock Support, Clockwise	2
3	Steel Castle Nut, M16x2mm, Class 8.8, ZP	4
4	Steel Cotter Pin, 1/8"x1.5", SS	4
5	Steel Hitch Pin, 3/8"x3.5", SS	4
6	Lock Plate, Clockwise	4
7	Lock Plate, Counter-Clockwise	2
8	Lock Bolt, Cab Side	2
9	Lock Bolt, Tailgate Side	2
10	Bridge Pin, M8, Spring Steel, ZP	2
11	Steel Carriage Bolt, 3/8"-16x1", Grade 5, ZP	12
12	Nylon Lock Nut, 3/8"-16, Grade 5, ZP	12
13	Lock Foot, Tailgate Side	2
14	Lock Foot, Cab Side	2
15	Weldment, Tailgate Side	1
16	Weldment, Cab Side	1

Tools Needed		
Torque Wrench	15/16" Wrench/Socket	9/16" Wrench/Socket

WARNING

- Ensure each [13,14] lock foot sits directly on top of the OEM pucks in your truck. Aftermarket bed liners should be trimmed away to allow access to the OEM pucks.
- These instructions are guidelines only. Actual installation is the responsibility of the installer and the owner.
- Use only supplied hardware for installation.

RATINGS

- 22,000 lb gross trailer weight (4,500 lb tongue weight). Do not exceed vehicle manufacturer's recommended towing capacity.

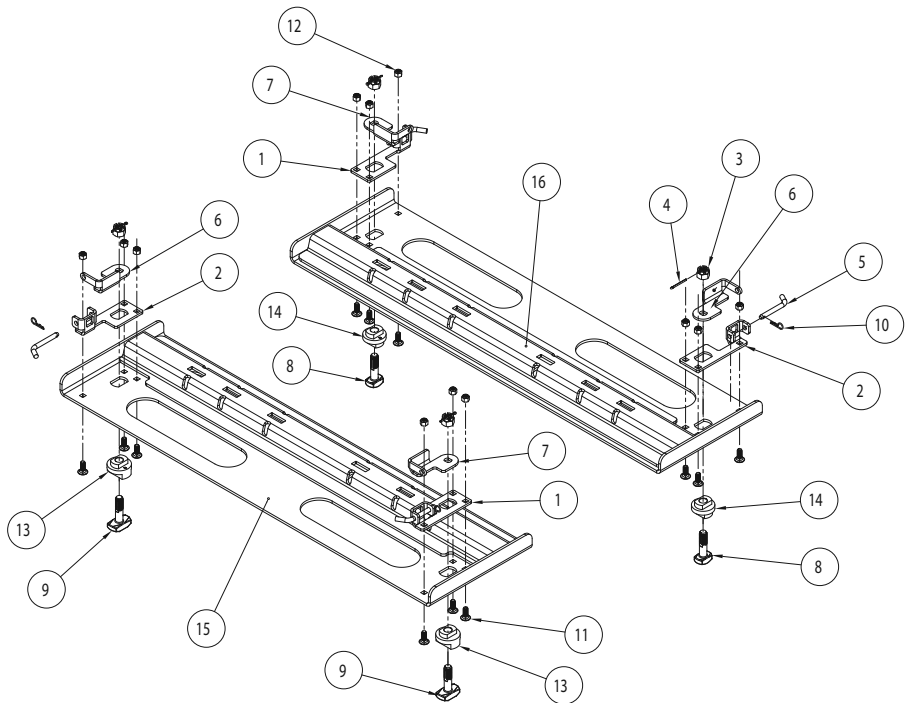

Installation Instructions

- Remove any existing bed rails, hitches, or other components from the bed of your truck.
- If applicable, remove puck covers from the four OEM puck locations.

CAMCO MFG., INC.
121 LANDMARK DRIVE / GREENSBORO, NC 27409 / USA
1-800-334-2004
WWW.CAMCO.NET

LIMITED WARRANTY: Camco warrants this product to be free from defects in material and workmanship under normal use and service conditions for 12 months from the date of first purchase. Camco's liability is limited solely to the replacement of any defective product returned to us. To the extent allowable by law, Camco makes no other warranty, either expressed or implied, nor assumes any liability for incidental or consequential damages resulting from the use of this product or for breach of warranty of merchantability or fitness for a particular purpose. Submit warranty claims to Camco Manufacturing, 121 Landmark Drive, Greensboro, NC 27409.

CONTINUED ON PAGE 2

CD895129 1019069R1 #519



CAMCO PRINTING INFORMATION (Do not Print)

Item Name: OEM 5th Wheel Adapter Instructions - Ram Puck Style
 New RM#: CD895129
 Old RM#: na
 Drawing #: 1019069
 Colors: 1/1 Black
 Coating: na
 Size: 8.5" x 11"
 Stock: 60# or 80# Text
 UPC: na
 Notes: na
 Rev #: 1
 Date Released: 519

ESKO Dieline Key

- Cut Line
- Crease Line
- Perforated Line
- Glue Area

PSL CutContour

No intentional introduction of Lead (Pb), Cadmium (Cd), Hexavalent Chrome and Mercury (Hg) allowed in manufacture of this packaging material. The sum of the concentration levels incidentally introduced not to exceed 100 PPM by weight.



OEM 5TH WHEEL ADAPTER RAM (PUCK STYLE)

MODEL #48662

- Remove [5] hitch pins and [10] bridge pins and rotate lock plates [6,7] 90 degrees into the unlocked position.

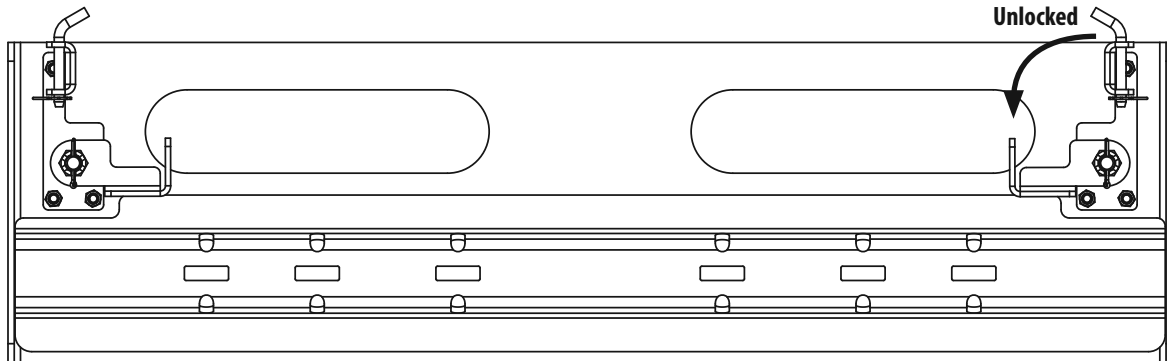

- Note: If there is too much resistance when rotating the lock plates, you may need to remove the [4] cotter pin and slightly adjust the [3] castle nut. Adjust to where the [8, 9] lock bolts and [6,7] locking plates feel snug but you can still rotate the locking plates with moderate hand pressure. Do not over tighten.
- Install the [16] cab side weldment (labeled with a "Cab Side" sticker) into the bed of your truck closest to the front seats in the shown configuration, making sure the [8] lock bolts slide into the puck slots on your truck.

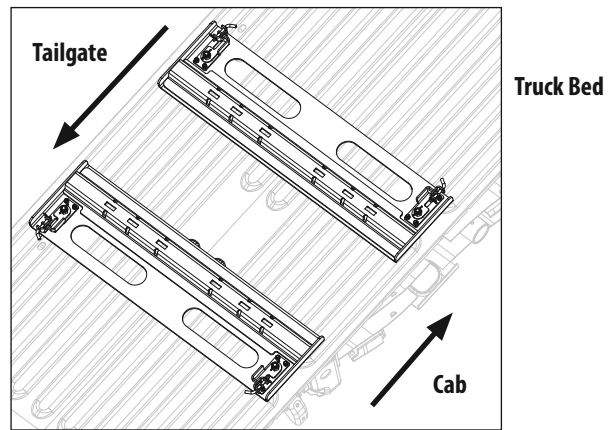
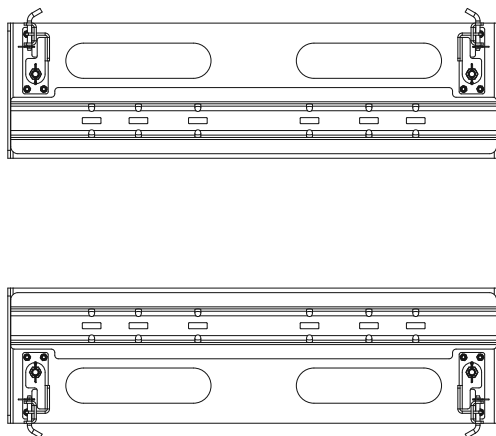

- Install the [15] tailgate side weldment (labeled with a "Tailgate Side" sticker) into the bed of your truck closest to the tailgate in the shown configuration, making sure the [9] lock bolts slide into the puck slots on your truck.
- Ensure that all twelve [12] lock nuts are tight to at least 25 ft. lb.
- After the cab side and tailgate side weldments are securely seated in the pucks, rotate the [6, 7] lock plates 90 degrees into the locked position.
- Insert the [5] hitch pins and [10] bridge pins once the locking plates are fully in the locked position.
- Install desired fifth wheel hitch or slider.

CAMCO MFG., INC.
121 LANDMARK DRIVE / GREENSBORO, NC 27409 / USA
1-800-334-2004
WWW.CAMCO.NET

LIMITED WARRANTY: Camco warrants this product to be free from defects in material and workmanship under normal use and service conditions for 12 months from the date of first purchase. Camco's liability is limited solely to the replacement of any defective product returned to us. To the extent allowable by law, Camco makes no other warranty, either expressed or implied, nor assumes any liability for incidental or consequential damages resulting from the use of this product or for breach of warranty of merchantability or fitness for a particular purpose. Submit warranty claims to Camco Manufacturing, 121 Landmark Drive, Greensboro, NC 27409.

