



Since 1952

OEM 5TH WHEEL ADAPTER GMC/CHEVY (PUCK STYLE)

MODEL #48661

CAREFULLY READ THE FOLLOWING INSTALLATION INFORMATION.

Item no	Description	Included
1	Steel Hitch Pin, 3/8" x 3-1/2", ZP	4
2	Steel Cotter Pin, 1/8" x 1-1/2", SS	4
3	Steel Castle Nut, M16x2mm, Class 8.8, ZP	4
4	Steel Carriage Bolt, 3/8"-16x1", Grade 5, ZP	12
5	Nylon Lock Nut, 3/8"-16, Grade 5, ZP	12
6	Lock Support, Clockwise	2
7	Lock Support, Counter-Clockwise	2
8	Lock Plate, Clockwise	2
9	Lock Plate, Counter-Clockwise	2
10	Lock Bolt	4
11	Lock Foot	4
12	Bridge Pin, M8, Spring Steel, ZP	4
13	Weldment, GMC/Chevy OEM Adapter	2

Tools Needed

Torque Wrench	15/16" Wrench/Socket	9/16" Wrench/Socket
---------------	----------------------	---------------------



WARNING

- Ensure each [11] lock foot sits directly on top of the OEM pucks in your truck. Aftermarket bed liners should be trimmed away to allow access to the OEM pucks.
- These instructions are guidelines only. Actual installation is the responsibility of the installer and the owner.
- Use only supplied hardware for installation.

RATINGS

- 22,000 lb gross trailer weight (4,500 lb tongue weight). Do not exceed vehicle manufacturer's recommended towing capacity.

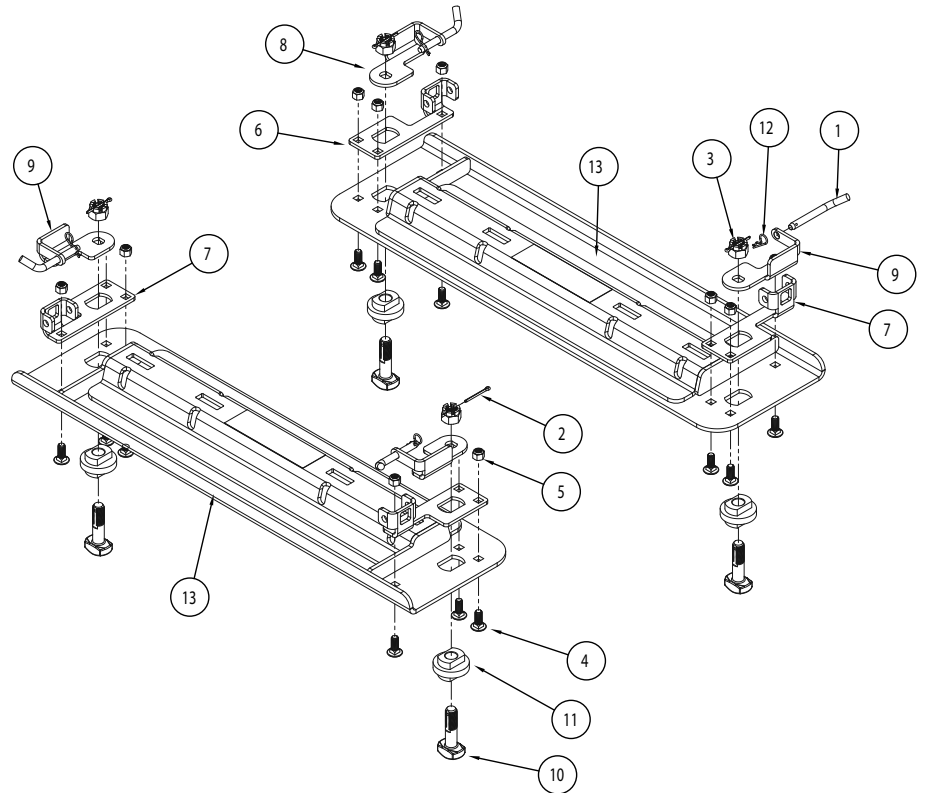

Installation Instructions

1. Remove any existing bed rails, hitches, or other components from the bed of your truck.
2. If applicable, remove puck covers from the four OEM puck locations.

CAMCO MFG., INC.

121 LANDMARK DRIVE / GREENSBORO, NC 27409 / USA
1-800-334-2004
WWW.CAMCO.NET

LIMITED WARRANTY: Camco warrants this product to be free from defects in material and workmanship under normal use and service conditions for 12 months from the date of first purchase. Camco's liability is limited solely to the replacement of any defective product returned to us. To the extent allowable by law, Camco makes no other warranty, either expressed or implied, nor assumes any liability for incidental or consequential damages resulting from the use of this product or for breach of warranty of merchantability or fitness for a particular purpose. Submit warranty claims to Camco Manufacturing, 121 Landmark Drive, Greensboro, NC 27409.

CONTINUED ON PAGE 2

CD895139 1018816R3 #1019



PRINTING INFORMATION (Do not Print)

Item Name: OEM 5th Wheel Adapter Instructions - Chevy/GMS Puck
New RM#: CD895139
Old RM#: CD895135
Drawing #: 1018816
Colors: 1/1 Black
Coating: na
Size: 8.5" x 11"
Stock: 60# or 80# Text
UPC: na
Notes: na
Rev #: 3
Date Released: 1019

ESKO Dieline Key

Cut Line

Crease Line

Perforated Line

Glue Area



PSL

CutContour

No intentional introduction of Lead (Pb), Cadmium (Cd), Hexavalent Chrome and Mercury (Hg) allowed in manufacture of this packaging material. The sum of the concentration levels incidentally introduced not to exceed 100 PPM by weight.



OEM 5TH WHEEL ADAPTER GMC/CHEVY (PUCK STYLE)

MODEL #48661

- Remove [1] hitch pins and [12] bridge pins and rotate lock plates [8,9] 90 degrees into the unlocked position.

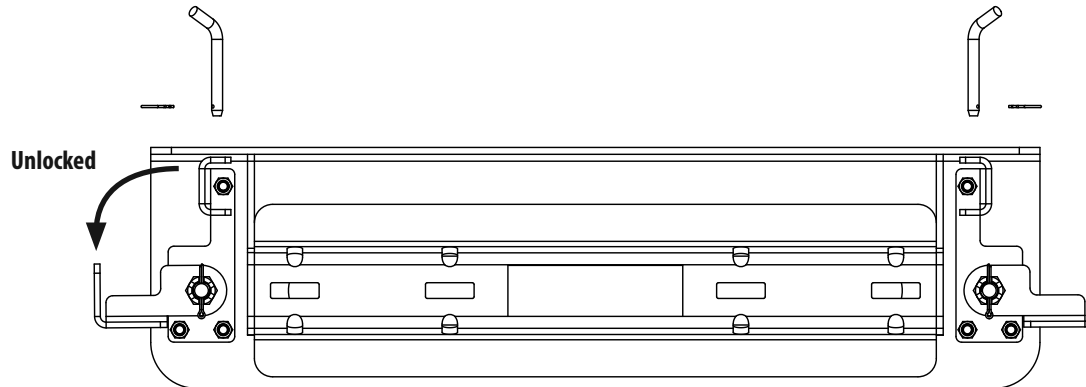

- Note: If there is too much resistance when rotating the lock plates [8,9], you may need to slightly adjust the [3] castle nut. Adjust to where the [10] lock bolts and locking plates feel snug but you can still rotate the locking plates with moderate hand pressure. Do not over tighten.
- Install the two [13] weldments into the bed of your truck in the shown configuration, making sure the [10] lock bolts slide into the puck slots on your truck.

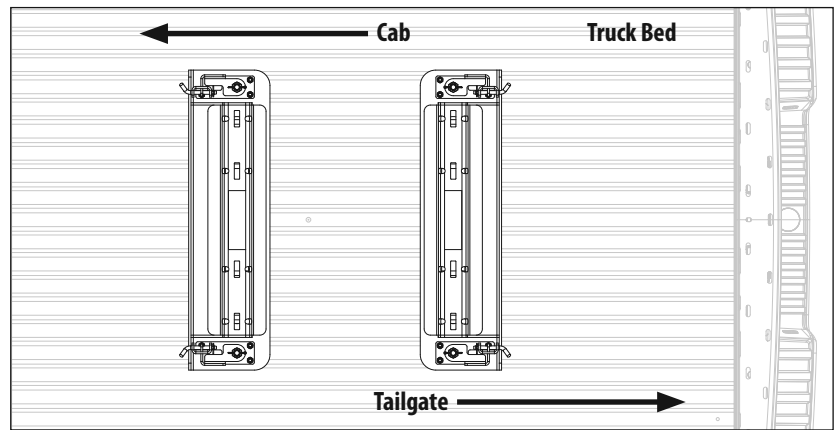
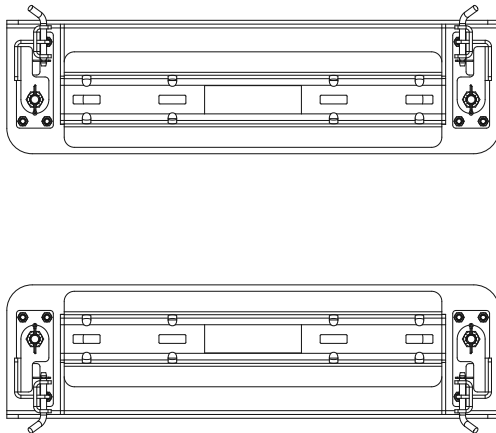

- Ensure that all twelve [5] lock nuts are tight to at least 25 ft. lb.
- After the weldments are securely seated in the pucks, rotate the lock plates 90 degrees into the locked position.
- Insert the [1] hitch pins and [12] bridge pins once the locking plates are fully in the locked position.
- Install desired fifth wheel hitch or slider.
- Note:** If Fifth Wheel or Slider hitch is not properly aligning with OEM Adapter, loosen castle nut [3] to allow adapter to settle into position. Lock nuts [5] can also be loosened to allow proper alignment. Once Fifth Wheel hitch is installed torque lock nuts [5] to 25 ft lb, tighten castle nut [3] and install cotter pin [2]. If there is still movement in the hitch system the castle nuts [3] can be torqued to 40 ft lb to eliminate. Be aware the lock plates [8,9] will not rotate into the unlocked position until the torque is taken off the castle nuts.

CAMCO MFG., INC.
121 LANDMARK DRIVE / GREENSBORO, NC 27409 / USA
1-800-334-2004
WWW.CAMCO.NET

LIMITED WARRANTY: Camco warrants this product to be free from defects in material and workmanship under normal use and service conditions for 12 months from the date of first purchase. Camco's liability is limited solely to the replacement of any defective product returned to us. To the extent allowable by law, Camco makes no other warranty, either expressed or implied, nor assumes any liability for incidental or consequential damages resulting from the use of this product or for breach of warranty of merchantability or fitness for a particular purpose. Submit warranty claims to Camco Manufacturing, 121 Landmark Drive, Greensboro, NC 27409.

