



FORD F-250/350/450

2004-2014 (NOT CAB-ON-CHASSIS)

RAIL MOUNTING BRACKET

FOR USE WITH 5TH WHEEL TRAILERS

MODEL #48592

● Includes:

No.	Description	Qty.
1	Bracket - Driver Rear	1
2	Bracket - Passenger Front	1
3	Fill Shim - Small	4
4	Pull Wire - 1/2"	4

○ Parts from 48590 Instructions:

No.	Description	Qty.
1	Base Rail	2
2	Frame Bracket - Straight	2
3	Carriage Bolt, 1/2 x 2-1/4" Round Head	2
4	Carriage Bolt, 5/8 x 3-1/2" Round Head	4
5	Spacer - Short Tube	4
6	Hex Nut - 1/2"	10
7	Hex Nut - 5/8"	4
8	Washer - Serrated 1/2"	10
9	Washer - Serrated 5/8"	4
10	Fill Shim - Small	2

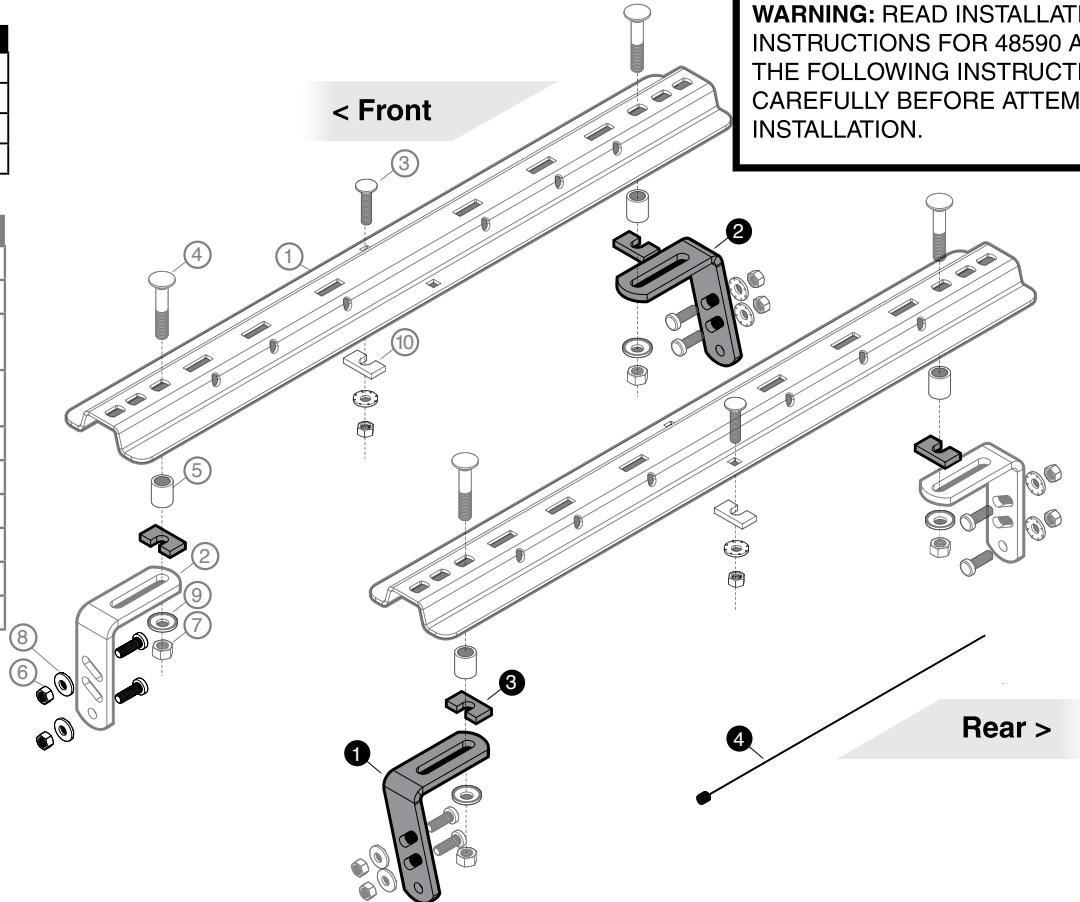

WARNING: READ INSTALLATION INSTRUCTIONS FOR 48590 AND THE FOLLOWING INSTRUCTIONS CAREFULLY BEFORE ATTEMPTING INSTALLATION.

Installation Instructions

! WARNING !

- Study, understand, and follow all instructions before operating this device.
- Failure to heed these markings may result in personal injury and/or property damage.
- These instructions are guidelines only. Actual installation is the responsibility of the installer and the owner. Always measure truck and trailer before installing hitch to be sure that there is clearance at the cab and at the bumper to allow for turns.
- If the truck is raised, be sure that the truck is properly blocked and restrained to prevent the truck from falling. Failure to do so may result in the truck suddenly falling, causing death or serious injury.
- Before drilling check for obstructions. Failure to do so could result in damage to fuel or brake lines, structural members, etc.
- Heavy Duty vehicles may have additional interference where brackets are mounted to frame. If interference with suspension components results, cut bolt flush to nut outboard of frame or use weld option.
- Do not lubricate bolts

CAUTION: CAMCO CANNOT BE HELD RESPONSIBLE FOR ANY DAMAGES DUE TO IMPROPER USE OR INSTALLATION OF THIS PRODUCT. CAMCO CANNOT BE HELD ACCOUNTABLE FOR THE STRUCTURAL INTEGRITY OF ANY FRAME.

Tools for Installation

- Electric drill
- 3/16" drill bit
- 17/32" drill bit
- 21/32" drill bit
- Ratchet w/extension
- 3/4" socket
- 15/16" socket
- 3/4" wrench
- Torque wrench capable of - 120 ft-lb
- C - clamps
- Appropriate safety protection (gloves, eye protection, etc.)

NOTICE

If product components are missing or damaged do not return to dealer, contact the manufacturer.
1-800-334-2004

Instructions

1. Read and follow steps 1-12 of manual 48590.
2. Rear edge of rear bed rail should be placed 30-5/16" from rear edge of truck bed.
3. On Driver's side install straight bracket at forward rail and the angled bracket at rear rail (pointing rearward). Bolt drivers side rear bracket using the top two slots.
4. On Passengers side install angled bracket at forward rail (pointing rearward) and the straight bracket at rear rail. Bolt passengers side front bracket using the top two slots.
5. Adjustment of base rail location up to 1/2" is permitted to not interfere with bed sills.
6. Torque all 1/2" nuts to 75 lb-ft and all 5/8" nuts to 120 lb-ft.

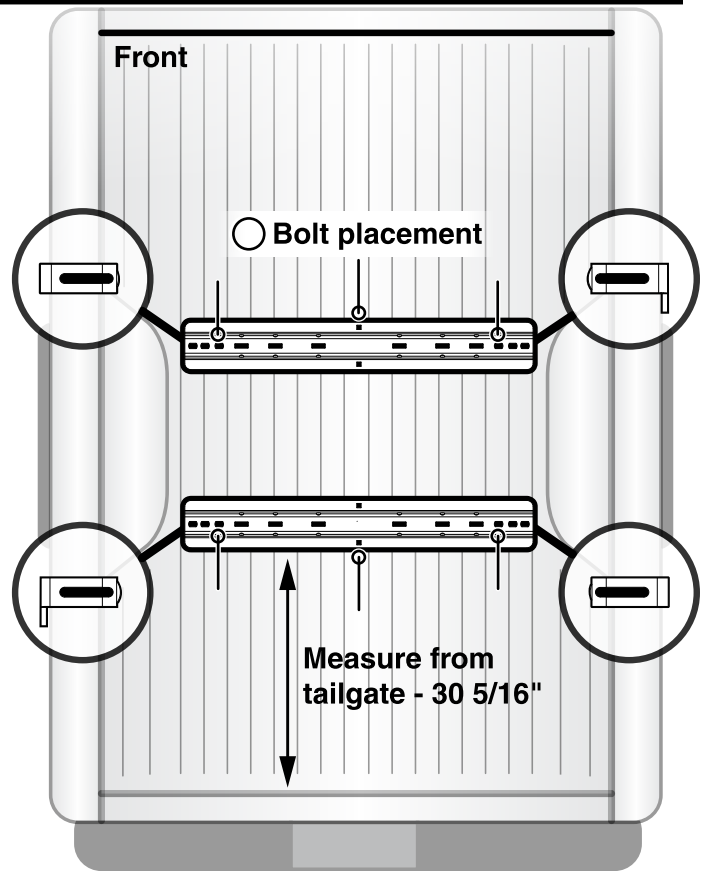
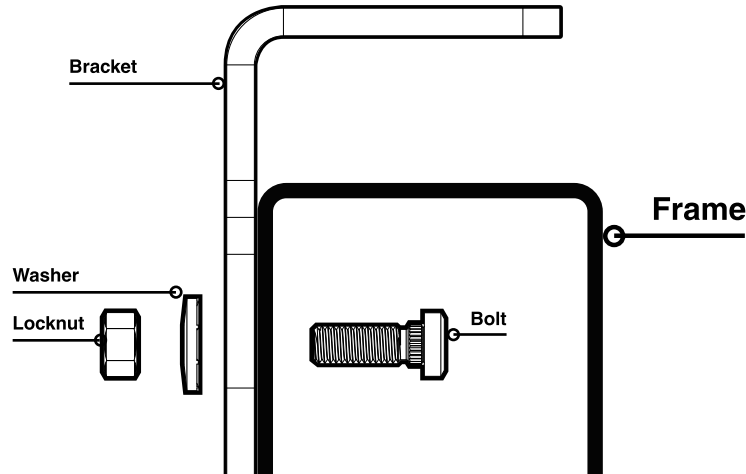

Driver Side View >>

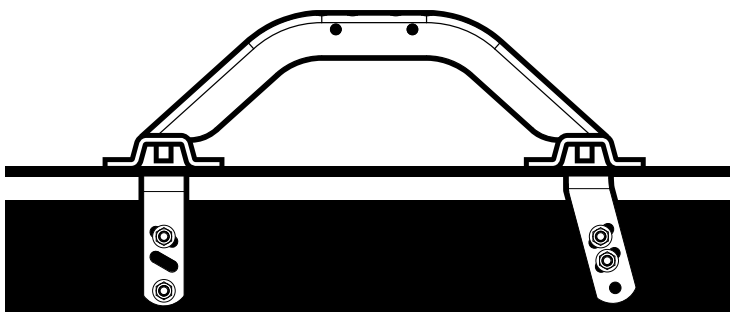

<< Passenger Side View

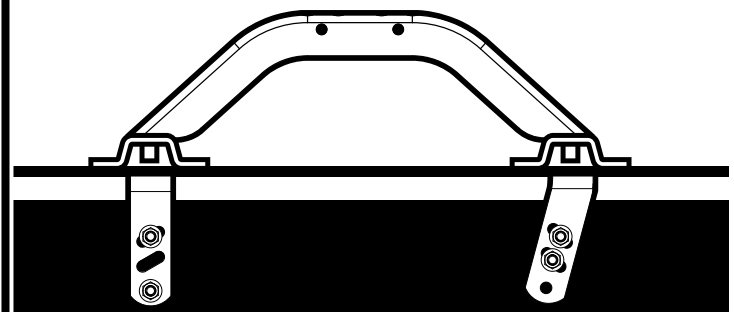

LIMITED WARRANTY

This Warranty applies solely to the Bracket (the "Product") manufactured by Camco Manufacturing, Inc. ("Camco")

1. Warranty and Warranty Period. Camco warrants to the original purchaser or consumer (the "Purchaser") of the Product will be free of defects in manufacture and workmanship for a period of 5 years from the date of consumer purchase or Camco will replace the Product free of charge (the "Warranty"). This Warranty is non-transferrable and applies only to the original vehicle on which the Product was installed.
2. Limitations on the Warranty. This Warranty does not cover the following: (a) normal wear and tear; (b) service or labor charges which are incurred in removing or replacing any Product; (c) the finish placed on the Product; (d) Product damage or failure which occurs as a result of abuse, neglect or misuse in any manner; and (e) damage which occurs to a Product that is misapplied, overloaded, improperly installed, or altered in any manner by anyone other than Camco.
3. Obligation of Purchaser. To obtain the benefits of this Warranty, the Purchaser must complete the following steps: (a) fill out online Warranty Registration within 10 days of purchase at www.camco.net/warranty; (b) promptly present the defective Product together with the proof of purchase to any of Camco dealer, distributor, or return it to the factory located at 121 Landmark Drive, Greensboro, NC 27409 and (c) pay all handling, transportation, and shipping charges incurred for the return of the defective Product. Any defective Product returned to Camco shall become the property of Camco.
4. Obligations of Camco. Subject to the terms and limitations set forth in this Warranty, Camco's sole obligation will be to replace for the original Purchaser free of charge any Product that is found to be defective.

5. Legal Rights. THIS WARRANTY GIVES YOU SPECIFIC LEGAL RIGHTS AND YOU MAY ALSO HAVE OTHER RIGHTS WHICH VARY FROM STATE TO STATE. CAMCO MAKES NO EXPRESSED OR IMPLIED WARRANTY OF MERCHANTABILITY OR FITNESS FOR A PARTICULAR PURPOSE. SOME STATES DO NOT ALLOW LIMITATIONS ON HOW LONG AN IMPLIED WARRANTY LASTS, SO THE ABOVE LIMITATIONS MAY NOT APPLY TO YOU.

CAMCO ASSUMES NO LIABILITY OR RESPONSIBILITY FOR BODILY INJURY THAT MAY BE INFLICTED ON THE PURCHASER, OPERATOR, SPECTATOR OR GENERAL PUBLIC WHO IS THE IN THE GENERAL AREA WHILE THIS EQUIPMENT IS IN USE, FOR THE LOSS OF THE USE OF ANY VEHICLE, LOSS OF TIME, RENTAL OF VEHICLES, LOSS OR DAMAGE TO PERSONAL PROPERTY, EXPENSES SUCH AS GASOLINE, TELEPHONE, LODGING, OR TOWING, OR ANY OTHER INCIDENTAL OR CONSEQUENTIAL DAMAGES INCURRED AS A RESULT OF THE USE OR OWNERSHIP OF ANY PRODUCT. SOME STATES DO NOT ALLOW THE EXCLUSION OF A LIMITATION OF INCIDENTAL OR CONSEQUENTIAL DAMAGES, SO THE EXCLUSION OR LIMITATION SET FORTH MAY NOT APPLY TO YOU. REPLACEMENT OF THE PRODUCT IN THE MANNER PROVIDED ABOVE SHALL CONSTITUTE FULFILLMENT OF ALL LIABILITIES OF CAMCO TO THE PURCHASER WHETHER BASED ON CONTRACT OR OTHERWISE.

CAMCO RESERVES THE RIGHT TO MAKE CHANGES IN DESIGN OR TO MAKE ADDITIONS OR IMPROVEMENTS WITHOUT BEING OBLIGATED TO INSTALL THE SAME UPON PRODUCTS COVERED BY THIS WARRANTY. THIS WARRANTY IS VALID ONLY IN THE UNITED STATES AND CANADA.

CAMCO MFG., INC.

121 Landmark Drive / Greensboro, NC 27409 / USA

1-800-334-2004

www.camco.net

