

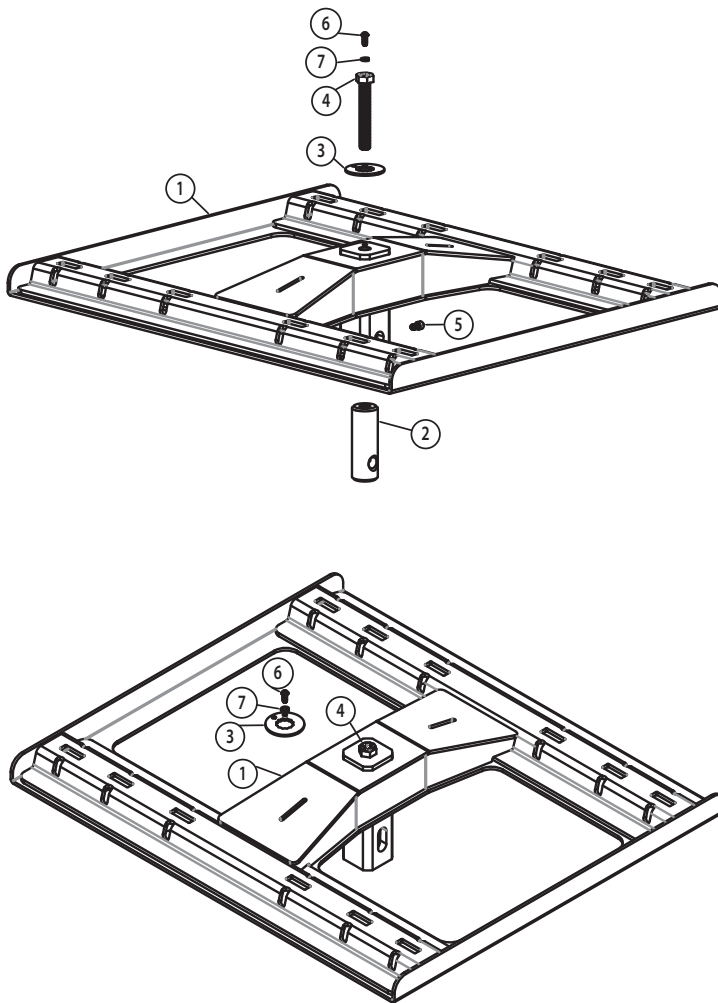

B&W Bed Hole Adapter

Parts List:

ITEM #	DESCRIPTION	QTY
1	WELDMENT, BW FIFTH WHEEL ADAPTER	1
2	PIN SLEEVE, B&W FIFTH WHEEL RAIL ADAPTER	1
3	LOCKWASHER, B&W FIFTH WHEEL RAIL ADAPTER	1
4	SCREW, 5/8"-11 X 4-1/4", HEX CAP, FULL THD, GRADE 8	1
5	SCREW, 5/16"-18 X 1/2", SHCS	1
6	SCREW, 1/4-20 X 5/8, BHSCS	1
7	LOCKWASHER, 1/4", SPLIT, STEEL, ZP	1



Instructions:

1. Remove any existing gooseneck ball or other hitch component.
2. Re-engage B&W locking pin. Measure from top of bed to top of lockpin. Record dimension.

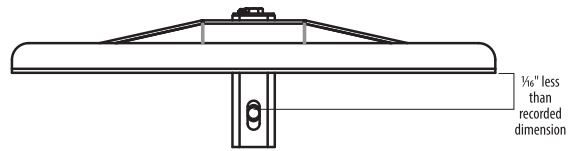
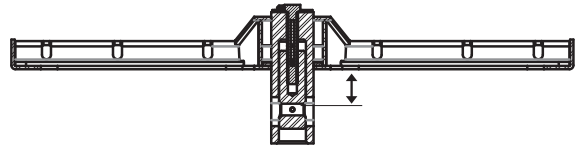

3. Remove [1] 1/4" screw [7] 1/4" lockwasher and [3] lockwasher from the top of the rail adapter. Adjust 5/8" bolt so the top of the pin sleeve cross hole measures approximately 1/16" less than dimension recorded in step #2.
4. Pull B&W lockpin and install rail adapter into the socket. Re-engage B&W lockpin. If pin does not fully engage, the top 5/8" bolt needs to be adjusted.
5. With B&W lock pin fully engaged, torque 5/8" bolt to 25-30 ft-lb. Install lockwasher and 1/4" screw to hold 5/8" bolt in place.

Warning:

Bed liners can affect adapter and lockpin alignment.

Ratings:

22,000 lb gross trailer weight (4,500 lb tongue weight). Do not exceed vehicle manufacturer's recommended towing capacity.

CD895127 1018722R1 #219



PRINTING INFORMATION

(Do not Print) 印刷资料 (不打印)

Item name: **B&W BedHole Adapter Instructions**
 Drawing#: **1018722**
 Colors: **1/0 (Black)**
 Coating: **no**
 Size: **8.5" x 11"**
 Die cut: **no**
 Stock: **20 lb bond**
 UPC: **N/A**
 Notes: **N/A**
 Rev #: **1**
 Date Released: **#219**

No intentional introduction of Lead (Pb), Cadmium (Cd), Hexavalent Chrome and Mercury (Hg) allowed in manufacture of this packaging material. The sum of the concentration levels incidentally introduced not to exceed 100 PPM by weight.