

D - MOTOR GROUP

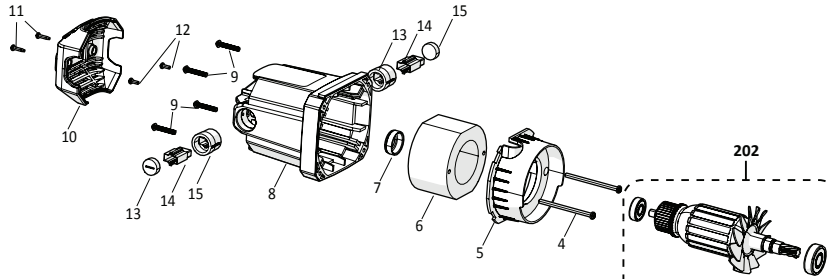

C - HANDLE GROUP

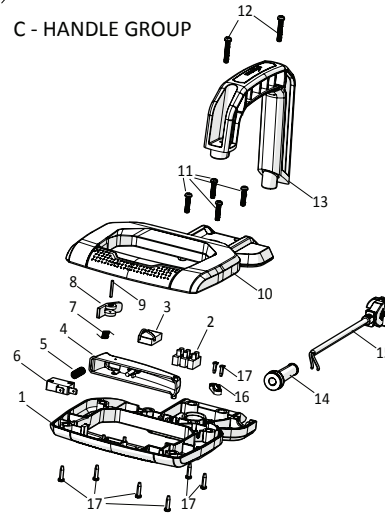

H - CHIP GUARD

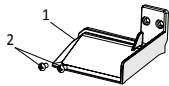

E - MAIN ARM GROUP

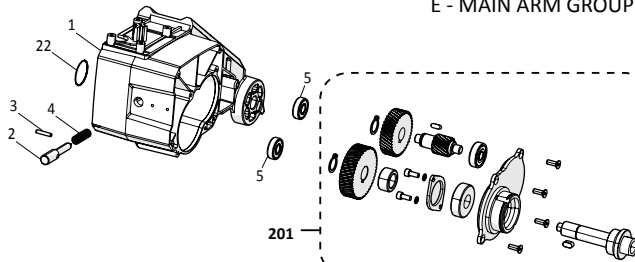

F - CLAMP GROUP

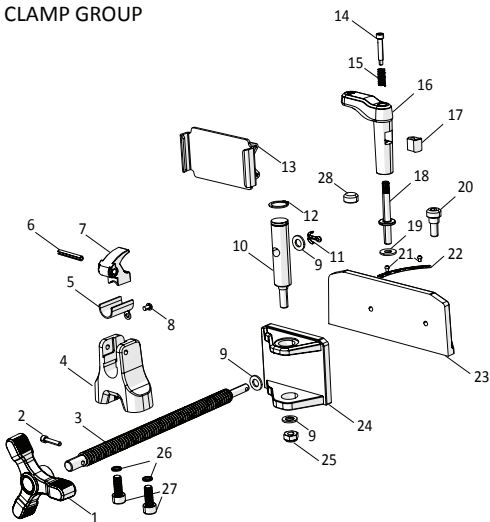

G - BASE GROUP

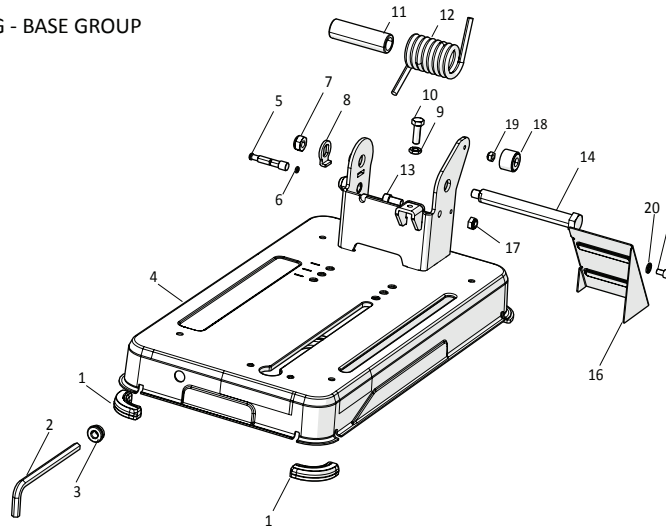

B - LINKAGE GROUP

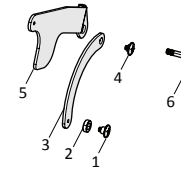

A - BLADE HEAD GROUP

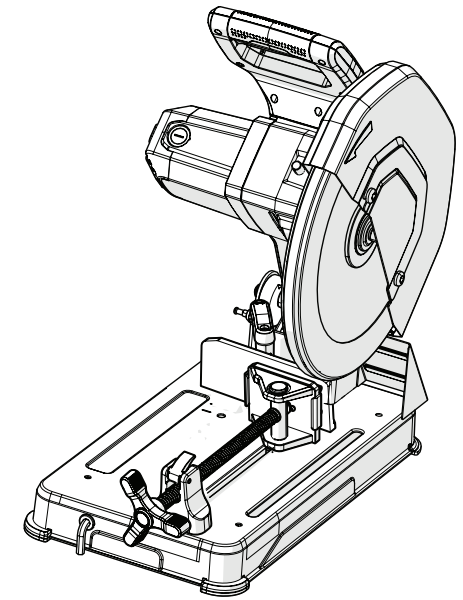
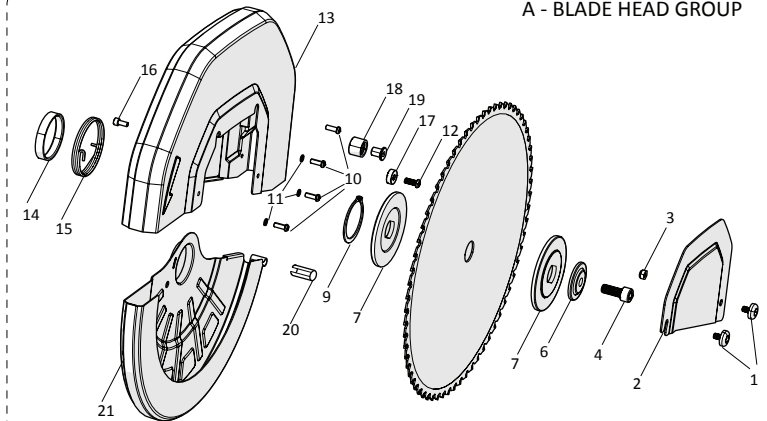

S355
CPSL

evolution[®]
evolutionpowertools.com

Service Parts List

V: 083-0010.01

14 Inch Metal Cutting Chop Saw

120V
US

No.	Description	Part Code	Qty
A01	Arbour Cover Screw	083-0101	2
A02	Arbour Cover	083-0102	1
A03	Locking Nut M6	F-NSH-M6-ST-BO	1
A04	Socket Cap Screw M10x25	F-SHCS-M10-25-ST-BO	1
A06	Blade Washer	083-0103	1
A07	Flange 89	083-0104	2
A09	Circlip φ48	F-CCEXT-48-120-ST-BO	1
A10	Pozi Pan Head Screw M5x14	F-SPHPZ-M5-14-ST-BO	4
A11	Spring Washer φ5	F-SWA-M5-ST-BO	3
A12	Pozi Pan Head Screw M6x12	F-SPHPZ-M6-12-ST-BO	1
A13	Blade Head Assembly 355	083-0105	1
A14	Moving Guard Spring Spacer 355	083-0106	1
A15	Moving Guard Spring	083-0107	1
A16	Socket Cap Screw M5x12	F-SHCS-M5-12-ST-BO	1
A17	Ball Bearing 606	F-B-606-2Z	1
A18	Bump Stop	083-0108	1
A19	Bump Stop Fixing	083-0109	1
A20	Slider Cap	083-0110	1
A21	Moving Guard Assembly 355	083-0111	1
B01	Linkage Shoulder Screw Upper	083-0115	1
B02	Screw Spacer	083-0116	1
B03	Small Linkage	083-0117	1
B04	Linkage Shoulder Screw Middle	083-0118	1
B05	Main Linkage	083-0119	1
B06	Linkage Shoulder Screw Lower	083-0120	1
C01	Main Handle Lower	083-0121	1
C02	Terminal Block	083-0122	1
C04	Main Trigger Blue	084-0106	1
C05	Main Trigger Spring	083-0126	1
C06	Switch	084-0172	1
C07	Trigger Lock Spring	083-0128	1
C08	Lock Trigger	083-0129	1
C09	Trigger Lock Pin	083-0130	1
C10	Main Handle Upper	083-0131	1
C11	Pozi Pan Head Screw M5x30 w/ Washer	F-SPHPZ-M5-30-ST-BO	4
C12	Pozi Pan Head Screw M5x30 w/ Washer	F-SPHPZ-M5-30-ST-BO	2
C13	Carry Handle	083-0132	1
C14	Cable Sleeve Small	083-0133	1
C15	Cable US 120V/R10f	084-0110	1
C16	Cable Strain Clamp	083-0140	1
C17	Pozi Pan Head Tapping Screw ST4x16	F-TFPX-4-16-ST-BO	8
D04	Pozi Pan Head Tapping Screw ST5x80	F-TFPX-5-80-ST-BO	2
D05	Air Baffle 65	084-0125	1
D06	Stator 65/110-120V 1800W/15A	084-0126	1
D07	Ball Bearing Cap	053-0270	1
D08	Motor Housing	083-0150	1
D09	Pozi Pan Head Screw M5x30 w/ Washer	F-SPHPZ-M5-30-ST-BO	4
D10	End Cap Blue	084-0131	1
D11	Pozi Pan Head Tapping Screw ST4x16	F-TFPX-4-16-ST-BO	2
D12	Pozi Pan Head Screw M4x10	F-SPHPZ-M4-10-ST-BO	2
D13	Brush Holder	083-0152	2
D14	Carbon Brush 110-120V	083-0154	2
D15	Brush Holder Cover	083-0155	2
D202	Armature 65 Assembly 110-120V UK/USA	084-0050	1

No.	Description	Part Code	Qty
E01	Arm	083-0160	1
E02	Arbour Locking Pin	083-0161	1
E03	Roller Pin 4x20	F-SDL-4-20-ST-BO	1
E04	Locking Pin Spring	083-0162	1
E05	Ball Bearing 6000 YQ	F-B-6000-2Z	2
E22	Rubber Bearing Ring	083-0196	1
E201	Gearbox Assembly (S355/380)	084-0055	1
F01	Clamp Bar Handle Blue	084-0132	1
F02	Pozi Pan Head Screw M5x25	F-SPHPZ-M5-25-ST-BO	1
F03	Clamp Bar - 20mm/Trapezoid	084-0133	1
F04	Clamp Bar Support - QR	084-0134	1
F05	Clamp Bar Wear Plate	084-0135	1
F06	Quick Release Vice Roller Pin	F-SDL-6-40-ST-BO	1
F07	Quick Release Vice	084-0137	1
F08	Pozi Pan Head Screw M5x8	F-SPHPZ-M5-8-ST-BO	1
F09	Washer φ10xφ20x2	F-W-M10-ST-BO	3
F10	Moving Vice Spindle - QR	084-0138	1
F11	Split Pin 3x25	083-0176	1
F12	Circlip φ22	F-CCEXT-22-120-ST-BO	1
F13	V-Vice Assembly - Steel	084-0139	1
F14	Quick Release Lever Shaft Screw	084-0142	1
F15	Locking Pin Spring	084-0143	1
F16	Quick Release Lever Blue	084-0144	1
F17	Quick Release Lever Shaft Insert	084-0145	1
F18	Quick Release Lever Shaft	084-0146	1
F19	Quick Release Lever Shaft Washer	084-0147	1
F20	Socket Cap Shoulder Screw	084-0148	1
F21	Pozi Pan Head Screw M4x5	F-SPHPZ-M4-5-ST-BO	2
F22	Fence Scale	084-0149	1
F23	Fence - Cast	084-0150	1
F24	Moving Vice Jaw - Cast	084-0151	1
F25	Locking Nut M10	F-NNIF-M10-ST-BO	1
F26	Spring Washer φ8	F-SWA-M8-ST-BO	2
F27	Socket Cap Screw M8x20	F-SHCS-M8-20-ST-BO	2
F28	Fence Blanking Plug (CPSL)	084-0171	1
G01	Rubber Foot 083	083-0184	3
G02	Allen Key S=8	F-HEXKEY-M6-ST-BO	1
G03	Rubber Grommet	083-0185	1
G04	Base Assembly	083-0186	1
G05	Head Lock-Down Pin 083	083-0187	1
G06	O Ring 4.5x1.8	083-0188	1
G07	Locking Nut M10	F-NNIF-M10-ST-BO	1
G08	Shaft Stop Washer	083-0189	1
G09	Hex Nut M8	F-NSF-M8-ST-BO	1
G10	Hex Screw M8x25	F-HSS-M8-ST-BO	1
G11	Main Torsion Spring Spacer	083-0190	1
G12	Main Torsion Spring 083	083-0191	1
G13	Socket Cap Screw M8x16	F-SHCS-M8-16-ST-BO	1
G14	Arm Pivot Shaft 083	083-0192	1
G15	Socket Cap Screw M6x10	F-SHCS-M6-10-ST-BO	1
G16	Chip Deflector - Pressed	083-0194	1
G17	Locking Nut M8	F-NNIF-M8-ST-BO	1
G18	Main Linkage Spacer	083-0193	1
G19	Locking Nut M6	F-NNIF-M6-ST-BO	1
G20	Spring Washer φ6	F-SWA-M6-ST-BO	1
H01	Chip Guard	084-0170	1
H02	Pozi Pan Head Screw M5x8	F-SPHPZ-M5-8-ST-BO	2

No.	Description	Part Code	Qty
 evolutionpowertools.com			
Service Parts List		V: 083-0010.01	
14 Inch Metal Cutting Chop Saw			120V US