

D - MOTOR GROUP

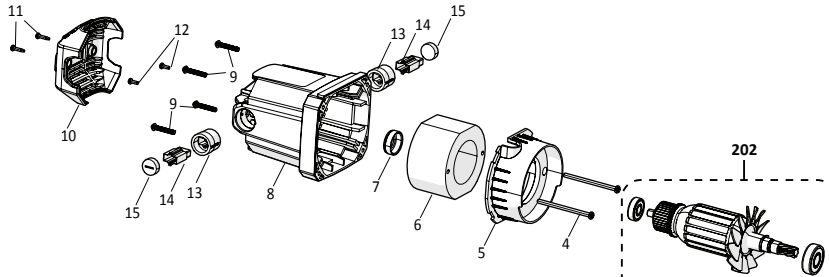

C - HANDLE GROUP

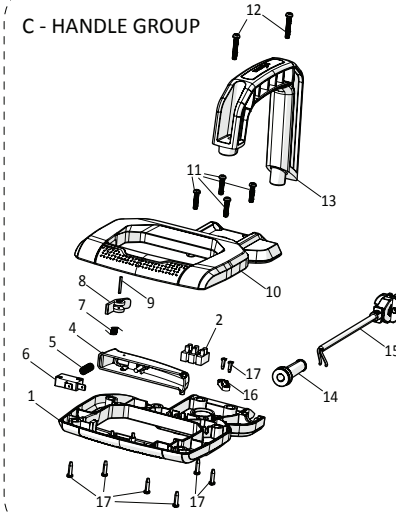

B - LINKAGE GROUP

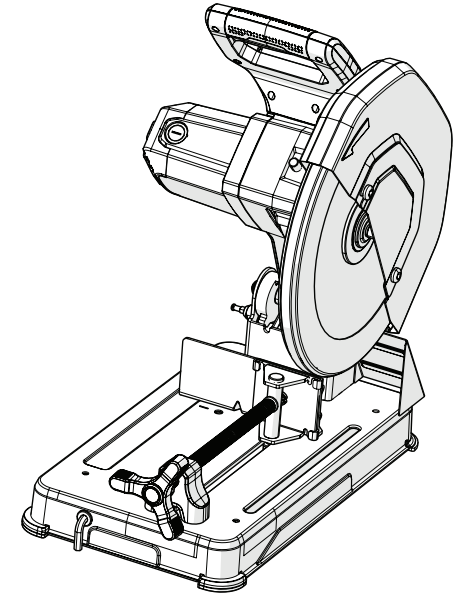
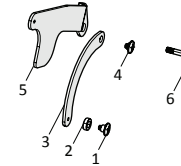

F - CLAMP GROUP

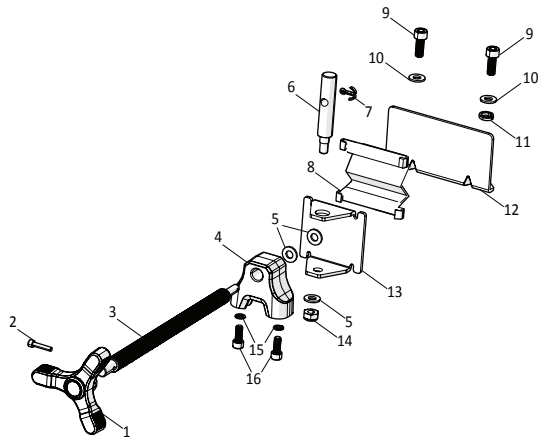

E - MAIN ARM GROUP

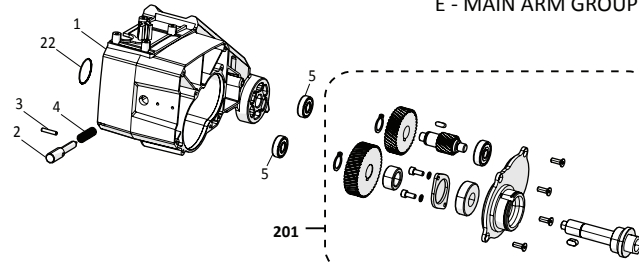

A - BLADE HEAD GROUP

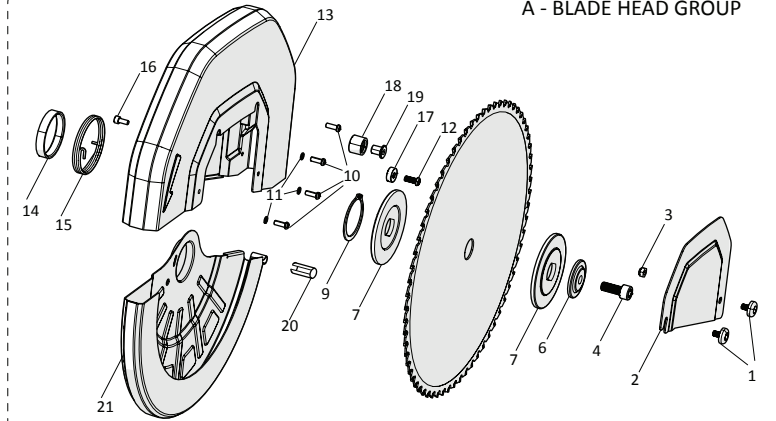

G - BASE GROUP

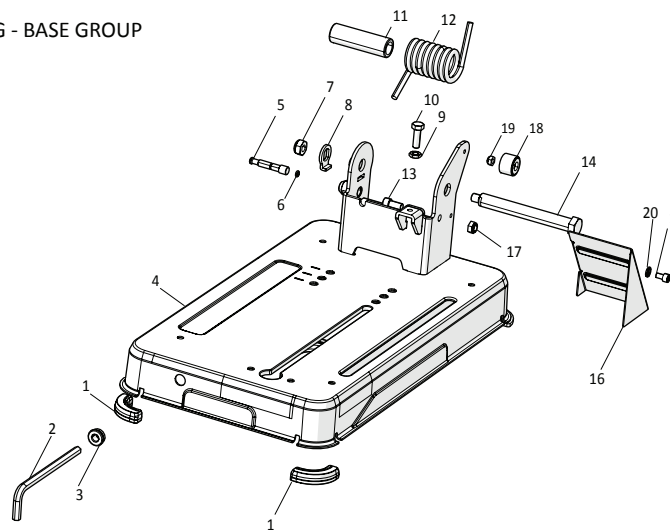

R355
CPS

evolution[®]
evolutionpowertools.com

Service Parts List

V: 083-0004.01

355mm Multi-Material Cutting Chop Saw

120V
US

No.	Description	Part Code	Qty
A01	Arbour Cover Screw	083-0101	2
A02	Arbour Cover	083-0102	1
A03	Locking Nut M6	F-NSH-M6-ST-BO	1
A04	Socket Cap Screw M10x25	F-SHCS-M10-25-ST-BO	1
A06	Blade Washer	083-0103	1
A07	Flange 89	083-0104	2
A09	Circlip φ48	F-CCEXT-48-120-ST-BO	1
A10	Pozi Pan Head Screw M5x14	F-SPHPZ-M5-14-ST-BO	4
A11	Spring Washer φ5	F-SWA-M5-ST-BO	3
A12	Pozi Pan Head Screw M6x12	F-SPHPZ-M6-12-ST-BO	1
A13	Blade Head Assembly 355	083-0105	1
A14	Moving Guard Spring Spacer 355	083-0106	1
A15	Moving Guard Spring	083-0107	1
A16	Socket Cap Screw M5x12	F-SHCS-M5-12-ST-BO	1
A17	Ball Bearing 606	F-B-606-2Z	1
A18	Bump Stop	083-0108	1
A19	Bump Stop Fixing	083-0109	1
A20	Slider Cap	083-0110	1
A21	Moving Guard Assembly 355	083-0111	1
B01	Linkage Shoulder Screw Upper	083-0115	1
B02	Screw Spacer	083-0116	1
B03	Small Linkage	083-0117	1
B04	Linkage Shoulder Screw Middle	083-0118	1
B05	Main Linkage	083-0119	1
B06	Linkage Shoulder Screw Lower	083-0120	1
C01	Main Handle Lower	083-0121	1
C02	Terminal Block	083-0122	1
C04	Main Trigger Orange	083-0124	1
C05	Main Trigger Spring	083-0125	1
C06	Switch	083-0126	1
C07	Trigger Lock Spring	083-0127	1
C08	Lock Trigger	083-0128	1
C09	Trigger Lock Pin	083-0129	1
C10	Main Handle Upper	083-0130	1
C11	Pozi Pan Head Screw M5x30 w/ Washer	F-SPHPZ-M5-30-ST-BO	4
C12	Pozi Pan Head Screw M5x30 w/ Washer	F-SPHPZ-M5-30-ST-BO	2
C13	Carry Handle	083-0132	1
C14	Cable Sleeve Small	083-0133	1
C15	Cable US 120V/P6f	083-0135	1
C16	Cable Strain Clamp	083-0140	1
C17	Pozi Pan Head Tapping Screw ST4x16	F-TFPX-4-16-ST-BO	8
D01	Ball Bearing 6202 HS	F-B-6202-2Z	1
D02	Armature 55/110-120V 1800W/15A	083-0141	1
D03	Ball Bearing 629 HS	F-B-629-2Z	1
D04	Pozi Pan Head Tapping Screw ST5x75	F-TFPX-5-75-ST-BO	2
D05	Air Baffle 55	083-0145	1
D06	Stator 55/110-120V 1800W/15A	083-0146	1
D07	Ball Bearing Cap	053-0270	1
D08	Motor Housing	083-0150	1
D09	Pozi Pan Head Screw M5x30 w/ Washer	F-SPHPZ-M5-30-ST-BO	4
D10	End Cap Orange	083-0151	1
D11	Pozi Pan Head Tapping Screw ST4x16	F-TFPX-4-16-ST-BO	2
D12	Pozi Pan Head Screw M4x10	F-SPHPZ-M4-10-ST-BO	2
D13	Brush Holder	083-0152	2
D14	Carbon Brush 110-120V	083-0154	2
D15	Brush Holder Cover	083-0155	2
D202	Armature 55 Assembly 110-120V UK/USA	083-0050	1

No.	Description	Part Code	Qty
E01	Arm	083-0160	1
E02	Arbour Locking Pin	083-0161	1
E03	Roller Pin 4x20	F-SDL-4-20-ST-BO	1
E04	Locking Pin Spring	083-0162	1
E05	Ball Bearing 6000 HS	F-B-6000-2Z	2
E06	Circlip φ16	F-CCEXT-16-100-ST-BO	1
E07	1st Drive Gear	083-0163	1
E08	Key 5x5x12	083-0164	1
E09	Gear Shaft	083-0165	1
E10	Ball Bearing 6200 HS	F-B-6200-2Z	1
E11	Circlip φ17	F-CCEXT-17-100-ST-BO	1
E12	2nd Drive Gear	083-0166	1
E13	Gear Spacer	083-0167	1
E14	Socket Cap Screw M5x12	F-SHCS-M5-12-ST-BO	2
E15	Spring Washer φ5	F-SWA-M5-ST-BO	2
E16	Bearing Bracket	083-0168	1
E17	Ball Bearing 6203 HS	F-B-6203-2Z	1
E18	Key 6x6x14	083-0169	1
E19	Gear Box Cover	083-0170	1
E20	Arbour Shaft	083-0171	1
E21	Socket Cap Countersunk Screw M5x15	F-SCHPZ-M5-15-ST-BO	4
E22	Rubber Bearing Ring	083-0196	1
E201	Gearbox Assembly (R355)	083-0055	1
F01	Clamp Bar Handle Orange	083-0172	1
F02	Pozi Pan Head Screw M5x25	F-SPHPZ-M5-25-ST-BO	1
F03	Clamp Bar - 16mm/Regular	083-0173	1
F04	Clamp Bar Support - STD	083-0174	1
F05	Washer φ10xφ20x2	F-W-M10-ST-BO	3
F06	Moving Vice Spindle - STD	083-0175	1
F07	Split Pin 3x25	083-0176	1
F08	V-Vice - Rage	083-0180	1
F09	Socket Cap Screw M10x25	F-SHCS-M10-25-ST-BO	2
F10	Washer φ10xφ23x4	083-0197	2
F11	Screw Spacer	083-0181	1
F12	Fence - Pressed	083-0182	1
F13	Moving Vice Jaw - Pressed	083-0183	1
F14	Locking Nut M10	F-NNIF-M10-ST-BO	1
F15	Spring Washer φ8	F-SWA-M8-ST-BO	2
F16	Socket Cap Screw M8x20	F-SHCS-M8-20-ST-BO	2
G01	Rubber Foot 083	083-0184	3
G02	Allen Key S=8	F-HEXKEY-M6-ST-BO	1
G03	Rubber Grommet	083-0185	1
G04	Base Assembly	083-0186	1
G05	Head Lock-Down Pin 083	083-0187	1
G06	O Ring 4.5x1.8	083-0188	1
G07	Locking Nut M10	F-NNIF-M10-ST-BO	1
G08	Shaft Stop Washer	083-0189	1
G09	Hex Nut M8	F-NSF-M8-ST-BO	1
G10	Hex Screw M8x25	F-HSS-M8-ST-BO	1
G11	Main Torsion Spring Spacer	083-0190	1
G12	Main Torsion Spring 083	083-0191	1
G13	Socket Cap Screw M8x16	F-SHCS-M8-16-ST-BO	1
G14	Arm Pivot Shaft 083	083-0192	1
G15	Socket Cap Screw M6x10	F-SHCS-M6-10-ST-BO	1
G16	Chip Deflector - Pressed	083-0194	1
G17	Locking Nut M8	F-NNIF-M8-ST-BO	1
G18	Main Linkage Spacer	083-0193	1
G19	Locking Nut M6	F-NNIF-M6-ST-BO	1
G20	Spring Washer φ6	F-SWA-M6-ST-BO	1

evolution[®]
evolutionpowertools.com

Service Parts List

V: 083-0004.01

355mm Multi-Material Cutting Chop Saw

120V
US