

KIT ASSEMBLY INSTRUCTIONS

Double DIN Mount Applications

NOTE: Remove shaded pocket support Tabs on left and right bracket.

1. Remove the shaded tab from the bottom of each left and right mounting bracket (See figure C below).
2. Cut and remove center rib from main frame and file edges smooth.
3. Attach the left and right side brackets to the main frame (See figure C below).
4. Follow steps 4-6 from single ISO instructions on page 3.
5. Attach a rear support bracket to the rear of the radio components and adjust as needed to allow rear support in the sub-dash (optional).

NOTE: #1 - ISO trim ring (DITR989) must be used in place of after-market radio's trim rings. For ISO mount applications, mount after-market radio components to side brackets using screws provided with radio when possible or hardware included with kit.

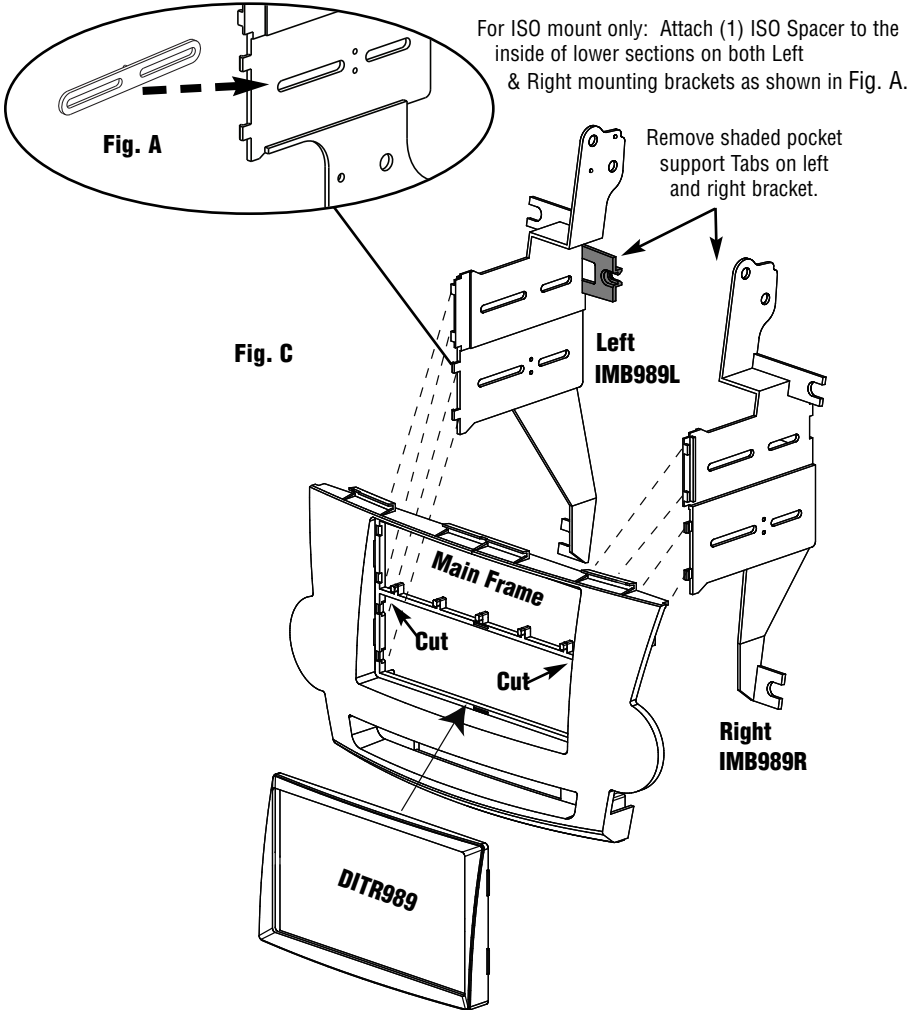

**American
International**
Car Stereo Installation Kits & Accessories

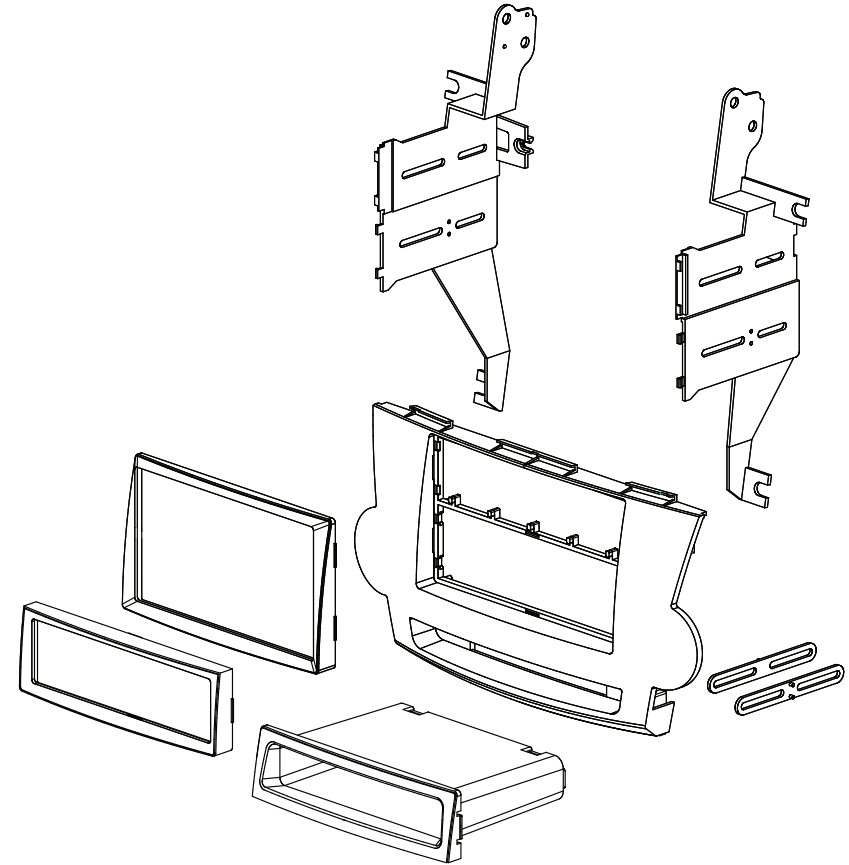

VEHICLE APPLICATIONS

Toyota
2008-12 HIGHLANDER (WITHOUT FACTORY NAVIGATION)

TOYK989 Mounting Kit

CUSTOMER HELP LINE

8am-4:30 P.S.T. Monday-Friday Except Holidays

USA 800-323-4329 • Canada 800-245-8777

iTOYK989

©2017 AMERICAN INTERNATIONAL INDUSTRIES, INC.

TECH Ver. 06/17 PRINT Ver. 06/17

DASH DISASSEMBLY AND RADIO REMOVAL INSTRUCTIONS

1. Carefully unclip and remove the vent panel above the radio. The vent panel is held to the sub-dash with plastic clips.
2. Lower the glove box door.
3. Remove the climate control panel that extends from the glove box down to the access door for the auxiliary plug and up to the key cylinder area. The access door is attached to the trim bezel.
4. Remove the (4) 10mm bolts securing the radio in place.
5. There are (4) plastic clips left holding the radio in the sub dash.
6. Carefully pull forward the radio assembly to remove from the sub-dash.
7. Disconnect all harnesses and antenna leads attached to the radio assembly.
8. Remove the hazard switch assembly from the radio mounting brackets.
This will need to be reinstalled into the new installation kit.
9. Remove the clock assembly from the radio mounting brackets (4) phillips screws).
This will need to be installed in the new kit.
10. Remove the 4 radio support studs from the back of the factory radio.

KIT ASSEMBLY INSTRUCTIONS

1. Remove the 4 factory radio (upper + lower side) support studs, as shown in Fig. D below, and attach to the rear side of the TOYK989 main bezel using the screws from the factory radio.

Fig. D

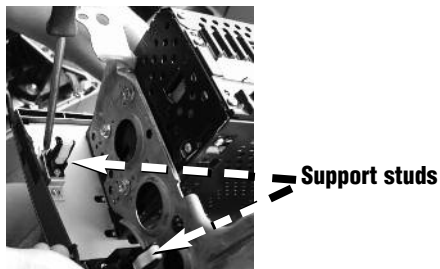

Single DIN Mount Applications

1. Attach the left and right side brackets to the main bracket. See Figure B opposite page.
2. Insert pocket (part # POC-989) into upper section of the main frame.
3. Attach left and right side brackets to the rear of the pocket using screws supplied.
4. Insert DIN sleeve from your new radio into the lower section of the installation kit.
5. Depress the tabs from inside the sleeves opening upward, outward, and downward to secure sleeve to the installation kit.
6. Install radio into sleeve and lock into place.
7. Attach a rear support bracket to the rear of the new radio and adjust as necessary to attach to the rear support stud located on the back of the pocket using the small phillips screw supplied with kit (optional).

NOTE: ISO trim ring (ITR989) may be used in place of after-market radio's removable trim ring. (Some radio faces may be too large and the trim ring may need to be modified)

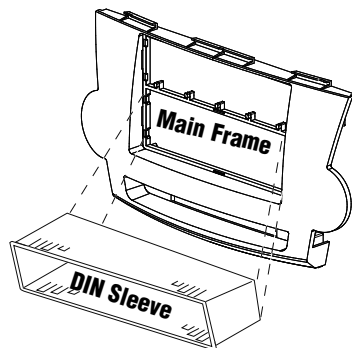

KIT ASSEMBLY INSTRUCTIONS

Single ISO Mount Applications

1. Attach the left and right side brackets to the main bracket. See Figure B.
2. Insert pocket (part # POC989) into upper section of the main frame.
3. Attach left and right side brackets to the rear of the pocket using screws supplied.
4. Attach (1) ISO Spacer to the inside of lower section on both Left & Right mounting brackets as shown in Fig. A.
5. Insert ISO mountable radio between ISO mount brackets and loosely attach to sides of radio using screws provided with radio when possible or hardware included with kit.
6. Slide radio component forward or backward for desired look and tighten screws.
7. Attach a rear support bracket to the rear of the new radio and adjust as necessary to attach to the rear support stud located on the back of the pocket using the small phillips screw supplied with kit (optional).

NOTE: #1 - ISO trim ring (ITR989) may be used in place of after-market radio's removable trim ring.

