

### 2007-2018 Jeep Wrangler (JK) 8-Inch Modular Multimedia Package

## Installation Guide

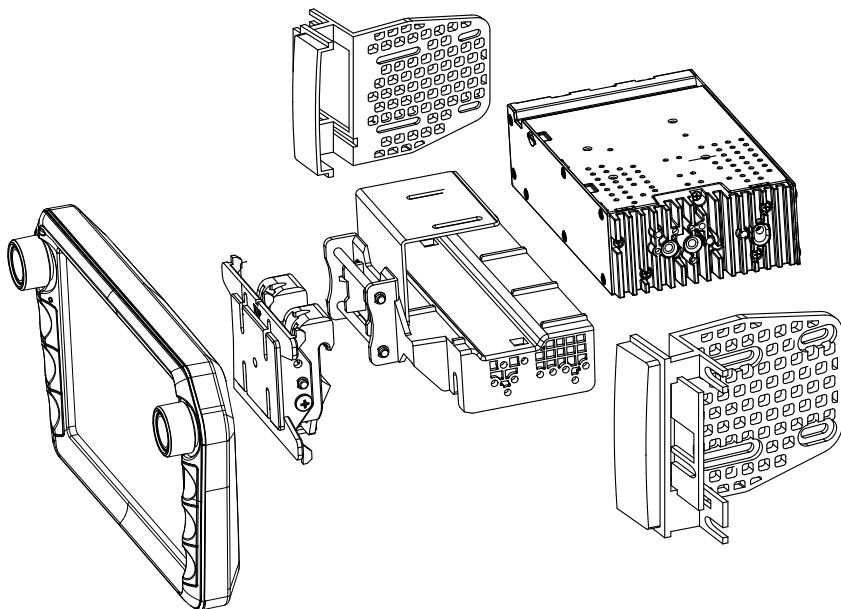

NOTE! Read this installation guide thoroughly before disassembling the vehicle or making wire connections. Installation of this product requires technical skill, experience, and specialized tools. If you feel uncomfortable performing the steps outlined in this manual, please have this product professionally installed by an authorized Stinger or AudioControl dealer.

For video installation guides visit:  
<https://stingerelectronics.com/installvideos>  
Search "Stinger HEIGH10 - STH10JK" for video installation  
of Stinger 10-inch version in 2007-20018 Wrangler JK.



# Contents

---

Kit Components.....	3
Vehicle Disassembly.....	4
Wiring and Connections.....	6
Radio and Display Assembly.....	9
Attaching Side Brackets.....	11
Harness Connections.....	12
GPS Antenna and USB.....	14
Vehicle Installation.....	15
Function Test.....	17
Vehicle Reassembly.....	18



## PRECAUTIONS

Disconnect the vehicle's negative battery cable before making any wire connections.

Protect all vehicle surfaces with tape or plastic.

Do not install components in any location that will hinder vehicle operation, such as steering wheel, gearshift, air bags, hazard switch.

Bundle cables and harnesses with electrical tape or wire ties to prevent them from interfering with moving parts.

Never attempt to disassemble or modify the product. Otherwise, an accident, fire or electric shock may result.

Exposed wires must be insulated with electrical tape. Otherwise, a short circuit, fire, or electric shock may result.

To prevent damage to the vehicle, confirm the locations of hoses, electrical wiring, and the fuel tank prior to drilling holes to install this product.

When it is necessary to replace the fuse, always use a fuse of the correct rating (number of amperes). Use of fuses with higher amperage ratings may cause a fire.

# Kit Components

---

NOTE! This installation guide outlines basic installation. For any additional features, adding a rear camera or amplifier, please refer to the additional instructions included with each component.

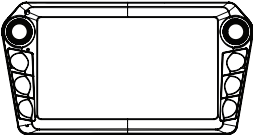

Stinger UN1880  
8" Multimedia System

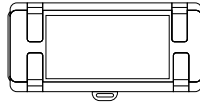

RP4-CH11  
Jeep Radio Interface

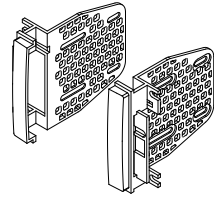

CDK642  
Radio Mounting Kit

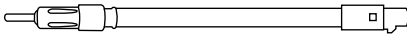

EU06  
Antenna Adapter

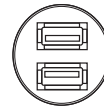

SSUSB2  
Dual USB Extension

## Recommended Tools

---

*Plastic Trim Tool*  
*7mm Socket*  
*Socket Extension*  
*Ratchet*  
*Phillips Screwdriver*

*Wire Crimpers*  
*Wire Strippers*  
*Battery Terminal Wrench*  
*Solder / Heat Shrink*  
*Wire Connectors*

**NOTE! Before starting disassembly, remove Negative Battery Cable.  
Protect vehicle surfaces with removable tape and/or towels.  
Place removed vehicle parts in a safe place.**

# Vehicle Disassembly (2011-2018)

1. Using a plastic trim tool, release the top left and right clips (1) and remove the knee bolster panel below the steering column.

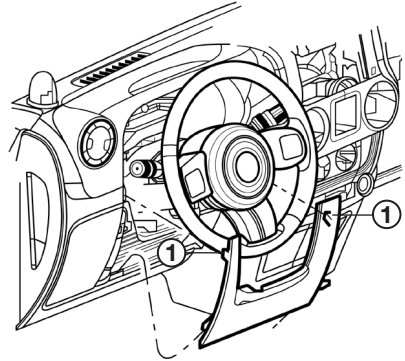

2. Using a plastic trim tool, gently pry to release and remove the power window switches or storage pocket below radio (2).

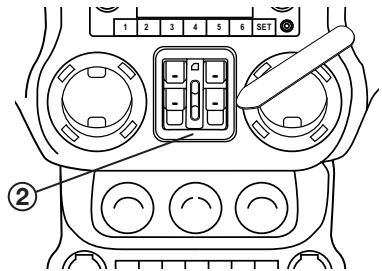

3. Remove storage bin mat on top of dash and remove the 7mm screw underneath (3).

4. Remove the two 7mm screws (4) from the bottom edge of the radio/instrument cluster trim panel on either side of the steering column.

5. Remove the 7mm screw (5) inside the switch opening.

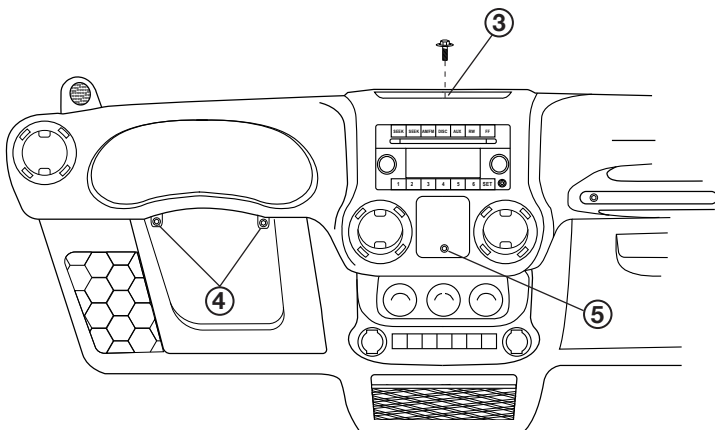

# Vehicle Disassembly (2011-2018)

NOTE! Position the steering wheel in the full down position.

6. Starting below the radio, reach into the window switch opening and firmly grasp the lower bezel and carefully pull the bezel to release the lower retaining clips (6).

7. Using the storage pocket and area over the gauges, pull entire panel and release the remaining upper retaining clips (7).

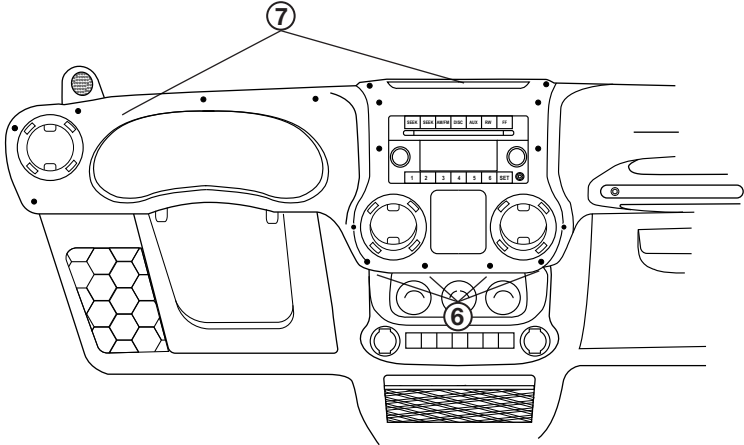

8. Remove the four 7mm screws (8) securing the radio. Remove the radio and unplug all the connectors from the back of radio and set to the side.

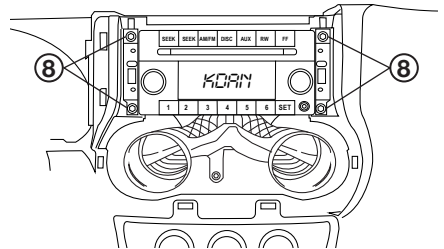

9. Remove the two 7mm screws (9) securing the metal bracket inside of the dash cavity and remove it.

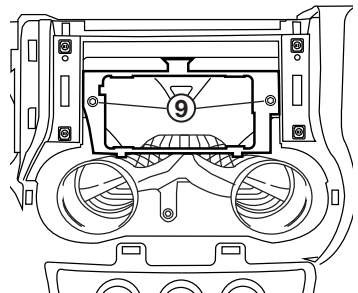

# Vehicle Disassembly (2007-2010)

1. Using a plastic trim tool, release the retaining clips on rear left and right of the upper panel above the radio. Tilt the panel upwards to release the front edge. If equipped, unplug the module on the backside of the panel.

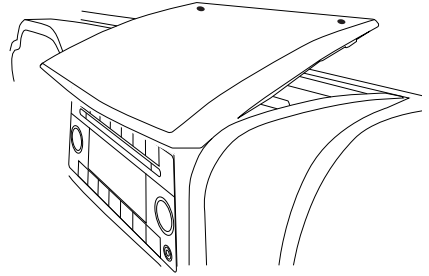

2. Using a plastic trim tool along the top of the lower center panel, gently pry to release the two retaining clips. Tilt downward and remove.

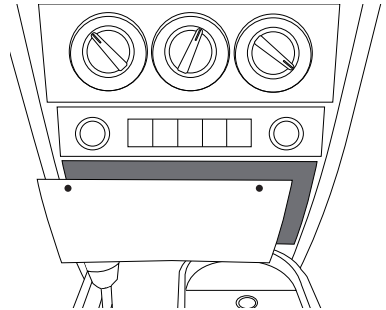

3. Using a 7mm socket, remove the two upper bolts securing the center panel.

Remove the two lower 7mm screws.

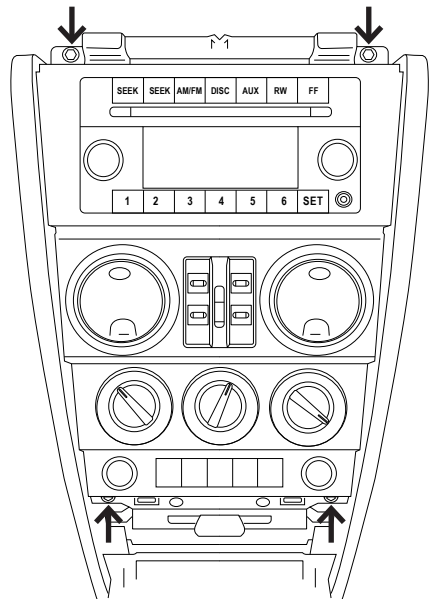

# Vehicle Disassembly (2007-2010)

4. Using your hands, pull outward on the top of the center bezel to release the clips on both sides of the radio.

Pull outward on the bottom of the center bezel to release the lower clips.

Finally, pull outward on the top and bottom of the panel to release the remaining two middle clips.

NOTE: For this installation guide, all the cables and connectors for the switches and climate controls on the backside of the center panel will be left attached. The panel will simply be moved out of the way to remove and install the radio.

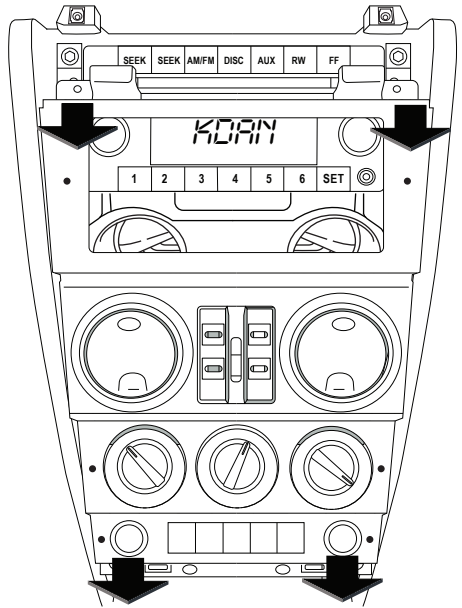

5. Remove the four 7mm screws securing the radio. Remove the radio and unplug all the connectors from the back of radio and set to the side.

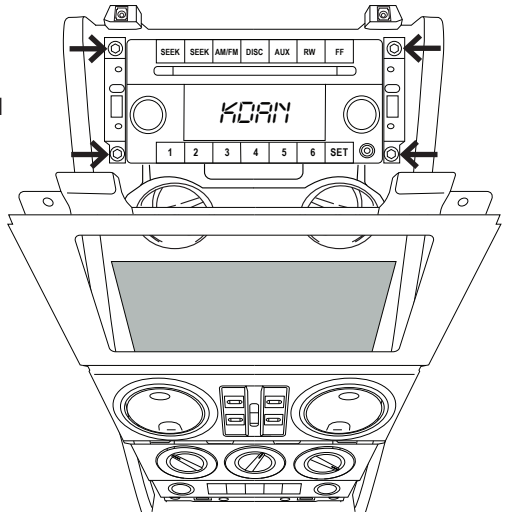

# Wiring & Connections

## **Parts Needed:**

### **From the ELEVE8 Box:**

- 16 Pin Power/Speaker Harness
- 10 Pin Multi Camera Harness
- 6 Pin SW/IR Harness (If vehicle is equipped with Steering Wheel Controls)

*\* Refer to pages 18-20 in the ELEVE8 Installation Guide for harness names and illustrations*

### **From the RP4-CH11 Box:**

- Main Harness RP4-CH11-B (Harness RP4-CH11-A will not be used in this application)
- 4 Pin SWC Connector (If vehicle is equipped with Steering Wheel Controls)

## **1. Determine if vehicle is equipped with a factory amplifier.**

After vehicle is disassembled, and before making any wire connections, determine if the vehicle has a factory amplifier by comparing the vehicle's radio plug to the diagrams below.

Inside the vehicle, locate the Gray 22 Pin plug that was unplugged from the factory radio. With the locking tab facing up and the wire side facing towards you, compare the vehicle plug to the diagrams below.

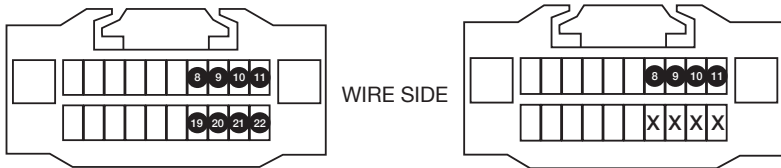

If there are 4 wires in pin locations 8-11 and 4 wires in pin locations 19-22, there is no factory amplifier.

Proceed to Step 2:  
Wiring Connections Without  
Factory Amplifier.

If there are 4 wires in pin locations 8-11 and no wires in pin locations 19-22, there is a factory amplifier.

Proceed to Step 3:  
Wiring Connections With  
Factory Amplifier.



# Wiring & Connections

## 2. Wiring Connections Without a Factory Amplifier.

Following the diagrams below, connect the wires from the ELEV8 harnesses to the RP4-CH11 harnesses as shown. The majority of the wire connections will match color-for-color. All wire connections should be made regardless if the feature is being used. For example, connect the reverse and amplifier wires even if no camera or amplifier are being installed. This will prevent unconnected wires from possibly shorting out.

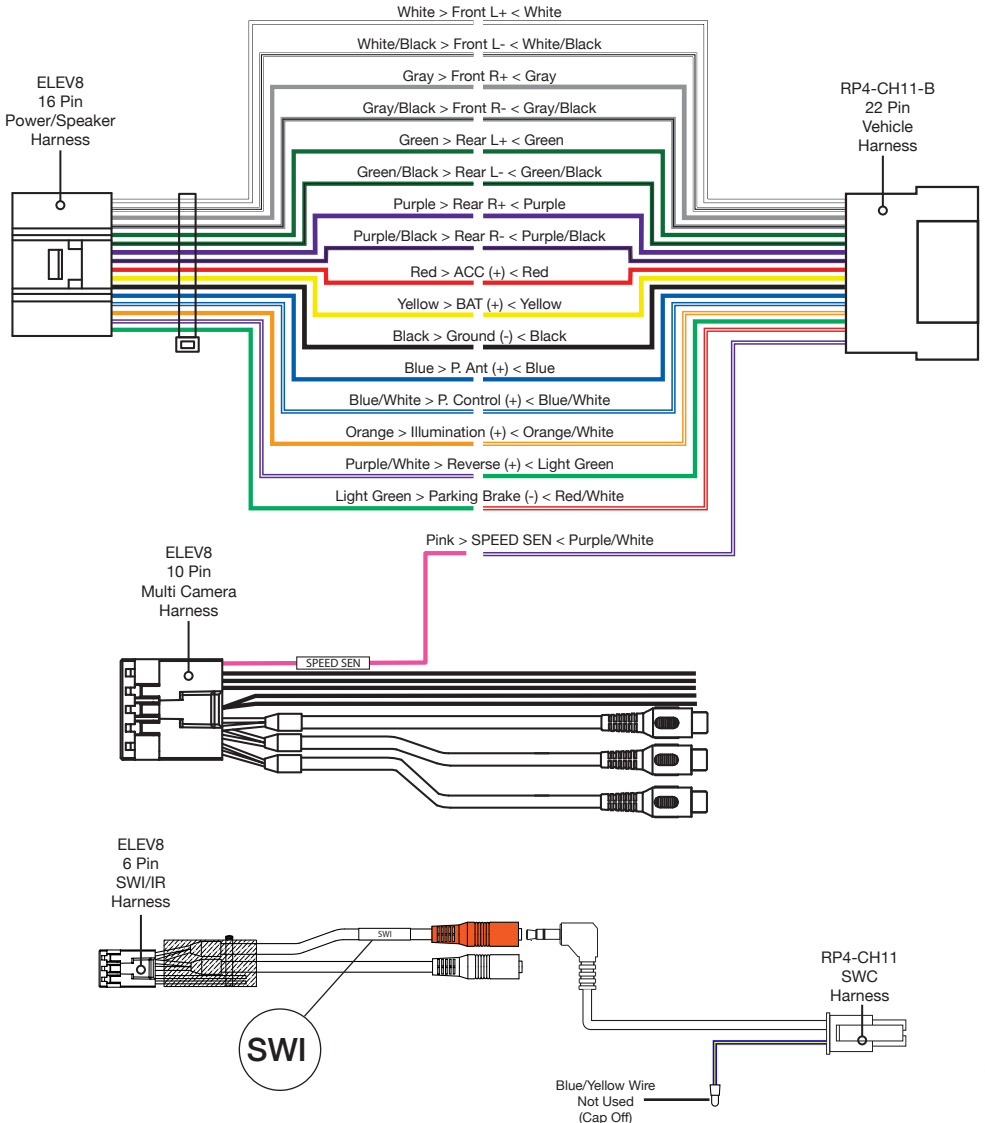

# Wiring & Connections

## 3. Wiring Connections With a Factory Amplifier:

Following the diagrams below, connect the wires from the ELEV8 harnesses to the RP4-CH11 harnesses as shown. For factory amplified vehicles, the front and rear speaker wires will be swapped. All wire connections should be made regardless if the feature is being used. For example, connect the reverse and amplifier wires even if no camera or amplifier are being installed. This will prevent unconnected wires from possibly shorting out.

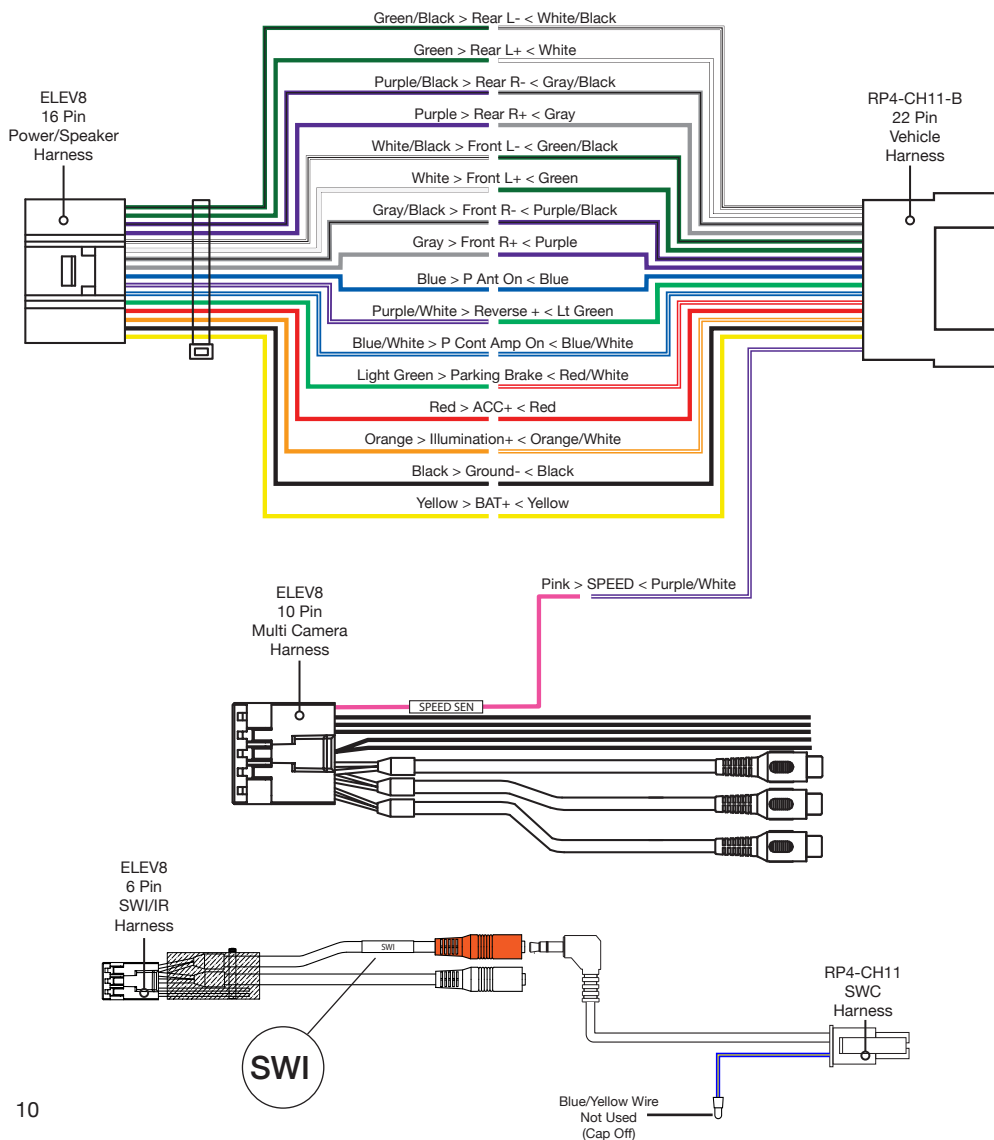

# Radio & Display Assembly

## Parts Needed:

From the ELEV8 Box:

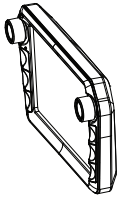

ELEV8 Display

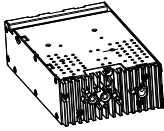

Radio Module

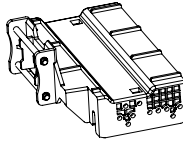

Plastic Mounting Bracket



Metal Mounting Bracket

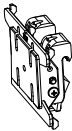

Display Mounting Clamp



M4 x 6 Screws (4)



M4 x 14 Screws (4)



M5 x 10 Screws (2)

**NOTE!** The *Display Mounting Clamp* is shipped connected to the *Plastic Mounting Bracket*. To remove the clamp assembly from the plastic mounting bracket push up from the compression spring side (1) and swing out to unhook top (2).

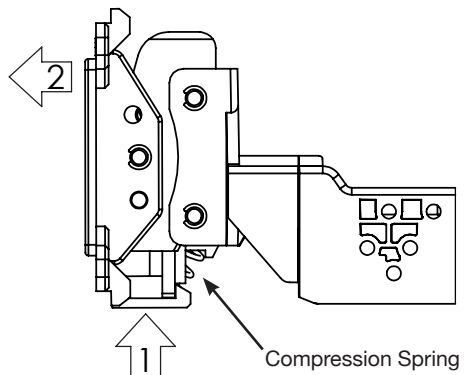

# Radio & Display Assembly

Start by attaching the *Metal Bracket* to the *Radio Module* using two M4 X 6 screws. The metal bracket should be flush against the front face of the radio module. Then attach the metal bracket to the *Plastic Mounting Bracket* using two M4 X 6 screws.

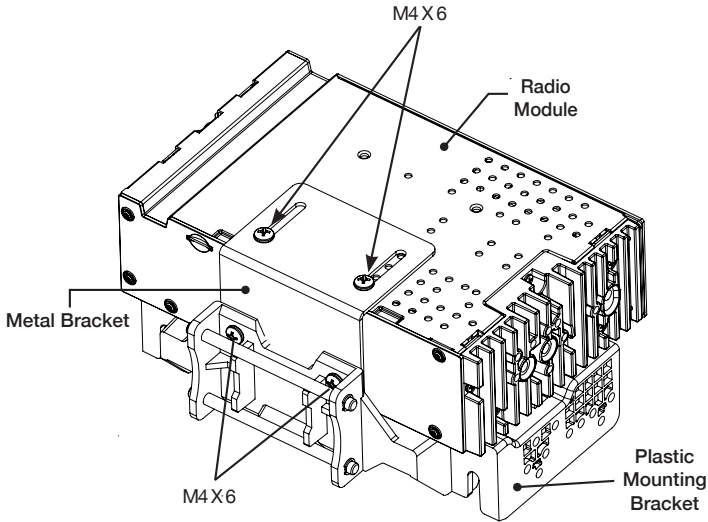

Attach the *Clamp Assembly* to the display using four M4 X 12 screws. Center the bracket on the back of the display as a starting point, and if needed, you can adjust up or down. Install one M5 x 10 screw in the lower holes on both sides of the bracket to lock in place.

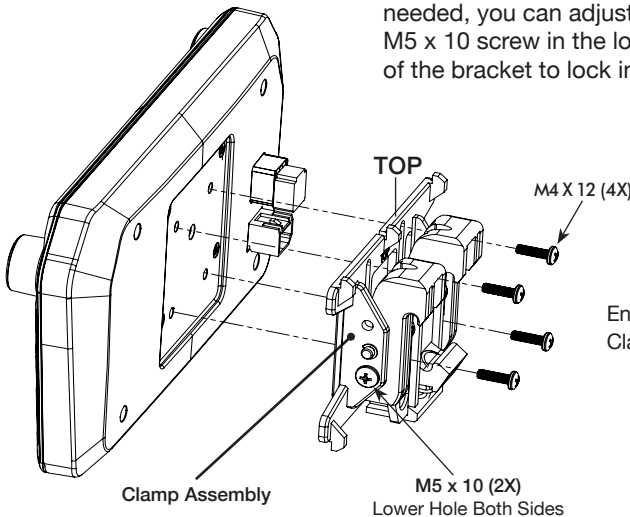

Ensure the **TOP** indicator on the Clamp Assembly is facing UP.

# Attaching Side Brackets

## Parts Needed:

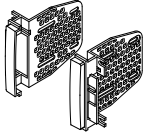

CDK642 Installation Kit



#10 X 3/8 Screws (4)

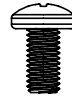

M5 X 10 Screws (4)

Turn the radio and bracket assembly so the plastic mounting bracket is on top as shown in FIG A.

From the CDK642 Installation Kit, determine the Right Side bracket using FIG B below...

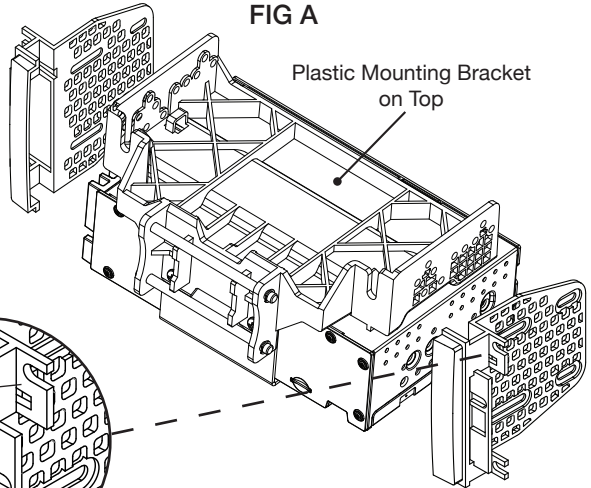

FIG A

Plastic Mounting Bracket on Top

FIG B: Right Side Bracket

Larger mounting tab on top

Curved opening on top of square opening

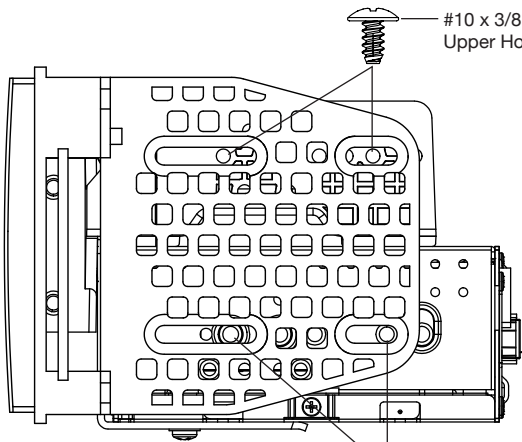
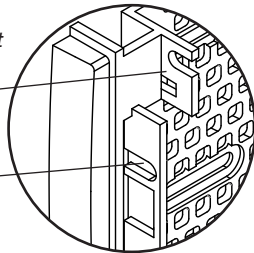

#10 x 3/8 (4X)  
Upper Holes Both Sides

M5 x 10 (4X)  
Lower Holes Both Sides

Position the right bracket as shown and loosely attach the bracket using two #10 x 3/8 coarse thread screws in the top positions, and two M5 x 10 in the bottom locations shown. Slide the bracket as far forward as the bottom slots will allow, tighten all four screws. Repeat for left side.

← FORWARD

# Harness Connections

---

## **Parts Needed:**

### **From the ELEV8 Box:**

- 8 Pin Display Power Harness
- LVDS Display Video Cable (Blue USB type)

### **From the RP4-CH11 Box:**

- RP4-CH11 Control Module
- EU06 Antenna Adapter
- 3 Harnesses from Step 2/3

Using a small flat blade screwdriver or similar, set the dial on the side of the RP4-CH11 module to Number 4. Remove the sticker covering the 16 Pin plug.

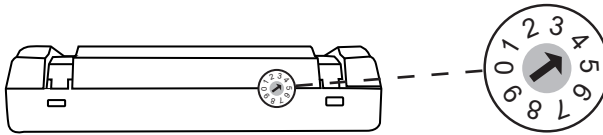

*Referring to FIG C at right, make the following connections:*

1. Plug the EU06 Antenna Adapter into the antenna connector
2. Plug in the LVDS Display Video Cable (Blue USB type)
3. Plug in the 8 Pin Display Power Harness
4. Plug in the 10 Pin Multi Camera Harness
5. Plug in the 16 Pin Power/Speaker Harness
6. Plug the 16 Pin Interface Harness into the RP4-CH11 module
- If the vehicle is equipped with Steering Wheel Controls*
7. Plug in the 6 Pin SWI/IR Harness
8. Plug in the 3.5mm headphone jack into the female 3.5mm marked SWI
9. Plug the 4 Pin SWC Harness into the RP4-CH11 module

NOTE! These are the connections for the basic installation, there are additional harnesses included with the ELEV8 kit (Amplifier, SiriusXM, Camera, Microphone, Aux). If not being used, it is recommended to save these as they might be needed in the future.

# Harness Connections

FIG C

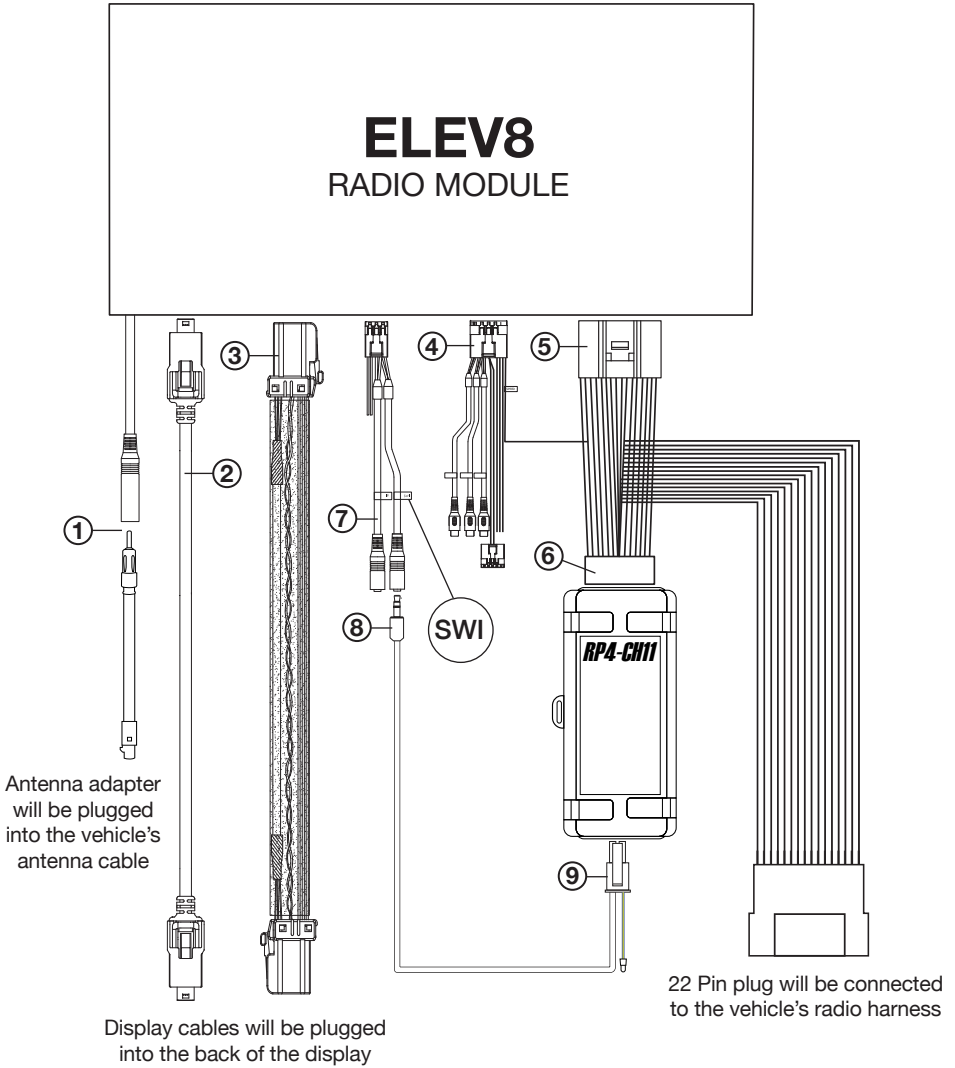

# GPS Antenna

## **Parts Needed:**

From the ELEV8 Box:

- GPS Antenna
- Metal Mounting Plate

Before installing the radio into the vehicle, mount the GPS Antenna and USB hub. The GPS antenna is required for proper operation of Apple CarPlay and Android Auto.

### **2011-2018 Models:**

In between the defroster vents and the gauges, there is a plastic mounting area that is used to mount the factory GPS antenna.

Clean the area and stick the metal mounting plate. Position the GPS antenna on the plate and route the GPS antenna cable down to the radio opening. Bundle and zip-tie the additional slack.

### **2011-2018 Models**

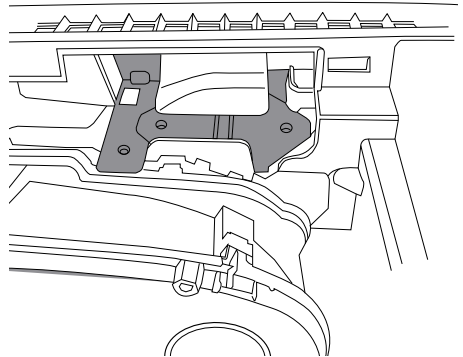

### **2007-2010 Models:**

On the left, above the radio opening there is a flat mounting area.

The metal mounting plate will need to be trimmed to fit the area.

**NOTE:** If the mounting plate is not trimmed, it will prohibit the top trim panel from fitting.

Clean the area and stick the metal mounting plate. Position the GPS antenna on the plate and route the GPS antenna cable down to the radio opening. Bundle and zip-tie the additional slack.

### **2007-2010 Models**

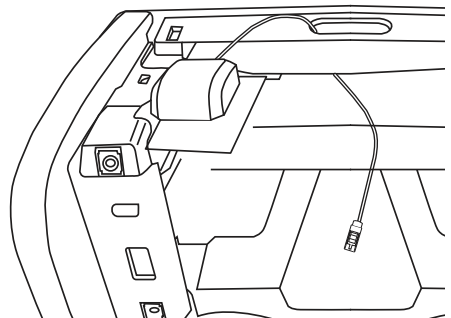



## **Parts Needed:**

- SSUSB2 Dual USB Extension

Apple CarPlay, Android Auto, and any Firmware Updates require access to a USB ports. The SSUSB2 is designed to extend the USB ports on the back of the ELEV8 to where they are accessible once the radio is installed.

For this installation, one of the factory 12V power outlets will be replaced with the SSUSB2. You may chose to follow these steps, or mount the USB port somewhere else in the vehicle.

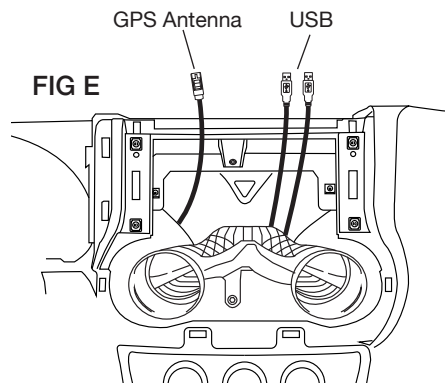
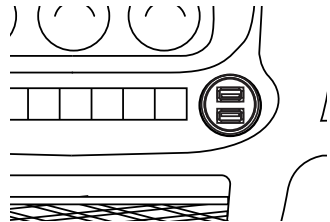
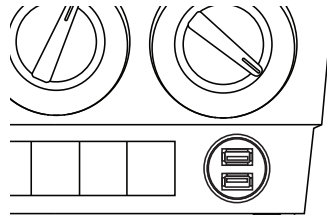

Once the USB ports are mounted, route the cables to the radio opening.

# Vehicle Installation

Inside the vehicle, with the complete radio assembly and harnesses, make the following connections.

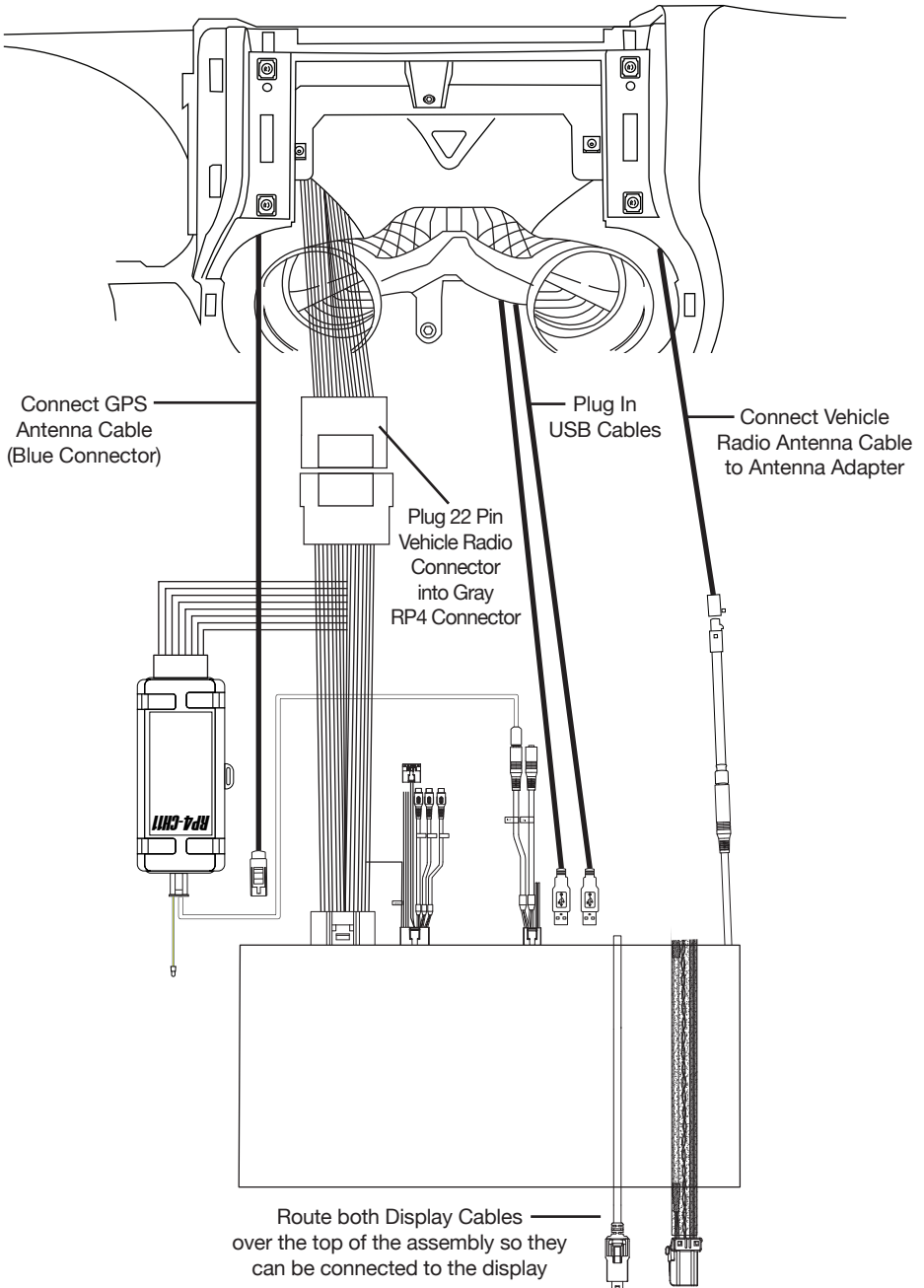

# Vehicle Installation

After all connections are complete, all excess wire, plugs, and the RP4 module need to be positioned on the left and right side of the air ducts (FIG F). The center area directly behind the radio needs to be kept clear so the radio assembly will fit.

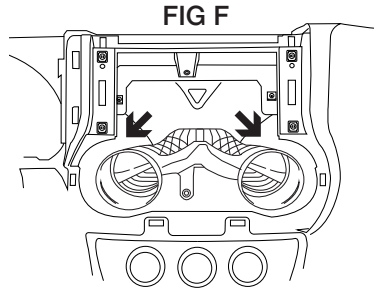

With the two display cables routed over the top of the assembly, slide the radio assembly into the dash and align the four mounting tabs on the side brackets. Reinstall the four 7mm screws (1).

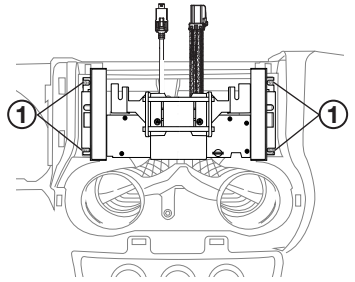

Before reassembling the vehicle, plug the two display cables into the back of the display and mount the display.

To Mount the Display:

- A - Hook the bottom hook to the bottom rail
- B - Push upward to compress the spring
- C - Hook the upper hooks on the upper rail

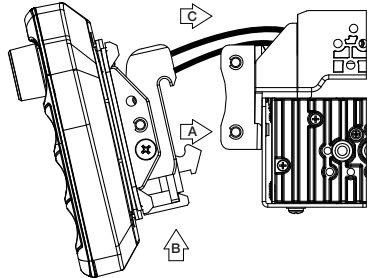

*NOTE: The vehicle sub-dash and radio cavity shown is 2011-2018 model year.  
The steps are the same for 2007-2010, it just looks a little different.*

# Function Test

---

*It's recommended to check all functions and features before reassembling the vehicle.*

Reconnect the Negative Battery Cable if removed.

The ELEV8 User Guide can be found at:

<https://stingerelectronics.com/products/ELEV8>

There is a TROUBLE SHOOTING section at the end of the User Guide.

- Start the vehicle, unit should power on.
- Check AM/FM reception.
- Check all Buttons and Volume/Power Knob.
- Press the HOME BUTTON and select SETTINGS > SOUND SETTINGS to access the audio settings. Check to make sure audio is playing through all speakers using Balance and Fade.
- Press the HOME BUTTON and select PHONE, then SETTINGS. If the External Microphone has not been installed, change Microphone to INTERNAL. Pair a phone and make a test call. *(Page 10 in User Guide)*
- Select BT Music and play audio from paired device
- Engage parking brake and insert a USB thumb drive with Audio and Video files into one of the USB Ports. Select USB as the source and check audio and video playback. Switch to the other USB port and check audio and video.
- To test Apple CarPlay and/or Android Auto, you will need to determine which USB port is the correct one. Plug an Apple or Android device into one of the USB ports. If the application does not launch, plug the device into the other USB port. *(See Pages 20-21 in the User Guide for more information on Apple CarPlay and Android Auto)*
- If vehicle is equipped with Steering Wheel Controls, confirm radio is responding when buttons are pressed.
- If vehicle is equipped with Rear Camera, place in reverse and confirm camera operation. If no camera has been installed, press the HOME BUTTON, then select SETTINGS, then CAMERA SETTINGS and set CAM 1 TRIGGER to OFF. Place vehicle in reverse and confirm display does not turn off in reverse.

## ***Need Help?***

You can reach Technical Support via Phone, Email or Chat.

Phone: 727-592-5991

Email: [support@aampglobal.com](mailto:support@aampglobal.com)

Chat: [stingerelectronics.com](https://stingerelectronics.com)

Tech Support Hours:

Mon-Fri 9AM-8PM EST

Sat 9AM-7PM EST

After testing is complete, remove the display by pushing up from the bottom (1), and pulling out on the top (2). Unplug the two display cables.

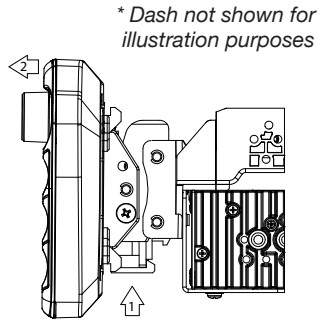

## Vehicle Reassembly

1. Position the Instrument Cluster/Radio Bezel (3). If equipped, locate the power window switch connector and pull through the switch opening (4). Align the bezel clips, push and fully seat all clips.
2. Install two 7mm screws left and right of steering column (5).
3. Install 7mm screw in the window switch/pocket opening (6).
4. Install 7mm storage bin screw (7) and the replace the bin mat.

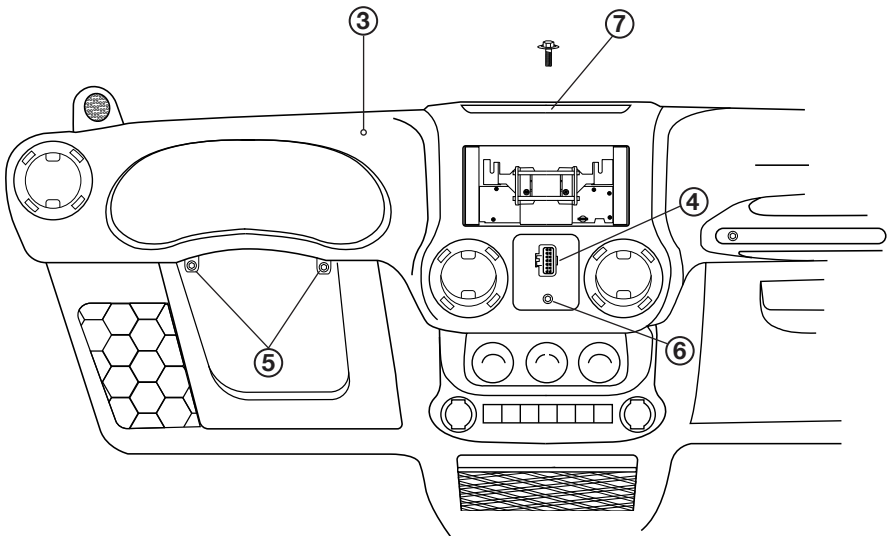

# Vehicle Reassembly 2011-2018

5. Reinstall the knee bolster panel (1) by aligning the two bottom tabs into lower slots and then locking the top clips on both sides of the steering column.
6. If equipped, plug in the power window switch connector and reinstall the switch assembly into the dash bezel (2).
7. Plug in the two ELEV8 display cables and re-mount the display (3).

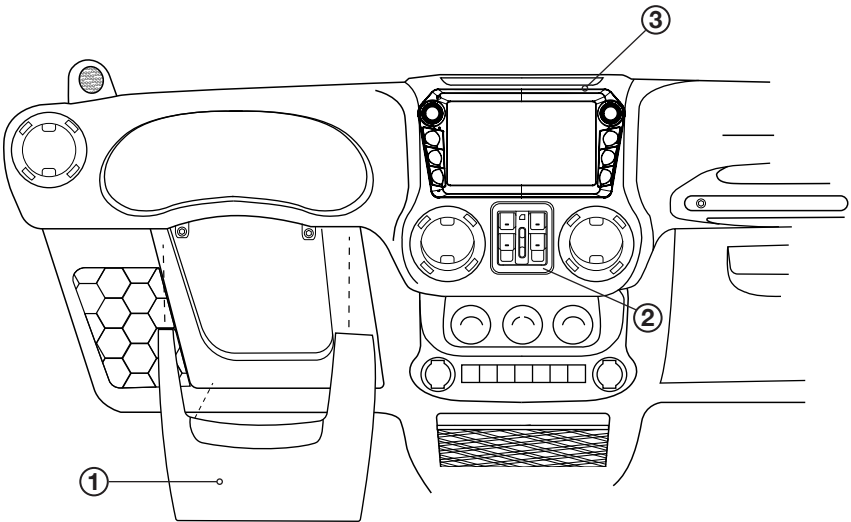

# Vehicle Reassembly 2007-2010

1. Align the main center panel (1) and push to seat all retaining clips.

2. Install two 7mm screws (2) in the upper center panel locations.

3. Install two 7mm screws (3) in the lower center panel locations.

4. Install the lower panel (4) by aligning the bottom tabs first, then snapping the upper clips into place.

5. Reconnect the module on the backside of the top panel (5) if equipped. Hook the front edge first then snap into place.

6. Plug in the two ELEV8 display cables and re-mount the display (6).

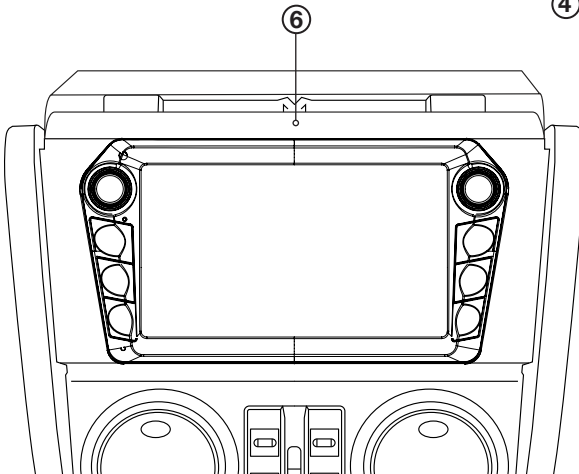
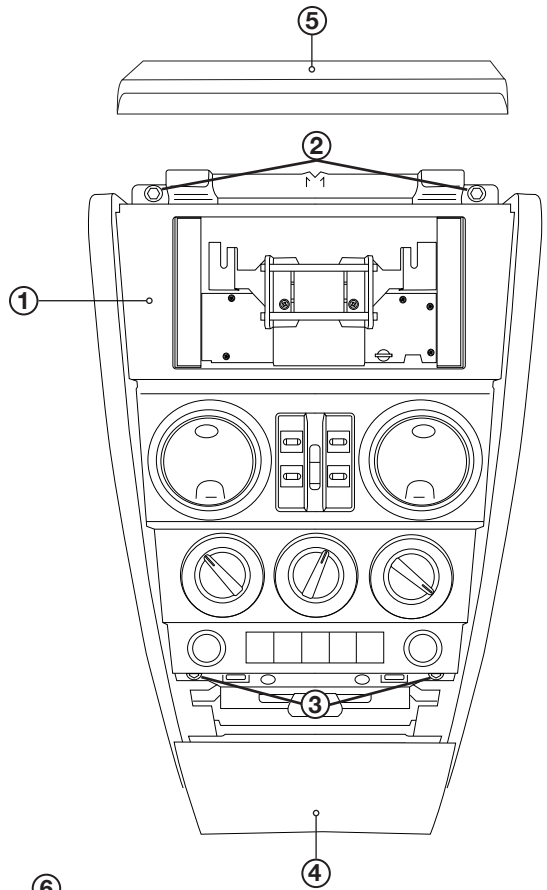



Stinger is a Power Brand of AAMP Global  
15500 Lightwave Drive, Suite 202  
Clearwater, Florida 33760

**CUSTOMER SOLUTIONS:**

800-477-2267  
Mon-Fri 9AM-8PM EST  
customersolutions@aampglobal.com

**TECHNICAL SUPPORT:**

727-592-5991  
Mon-Fri 9AM-8PM EST  
Sat 9AM-7PM EST  
support@aampglobal.com

AGREEMENT: End user agrees to use this product in compliance with the instructions and terms of use and with all State and Federal laws. STINGER provides instructions and safety warnings with respect to this product and disclaims all liability for any use not in conjunction with those instructions or other misuse of its product. If you do not agree, please discontinue use and contact STINGER. This product is intended for off-road use and passenger use only.