

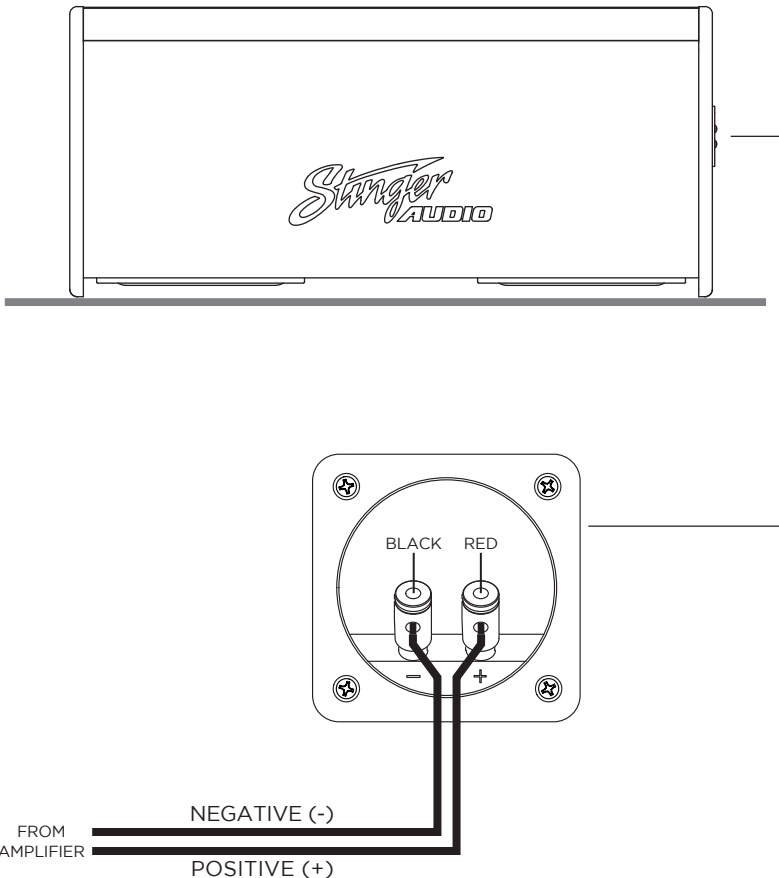

# DC2D10B

## DUAL 10-INCH PORTED SUBWOOFER ENCLOSURE

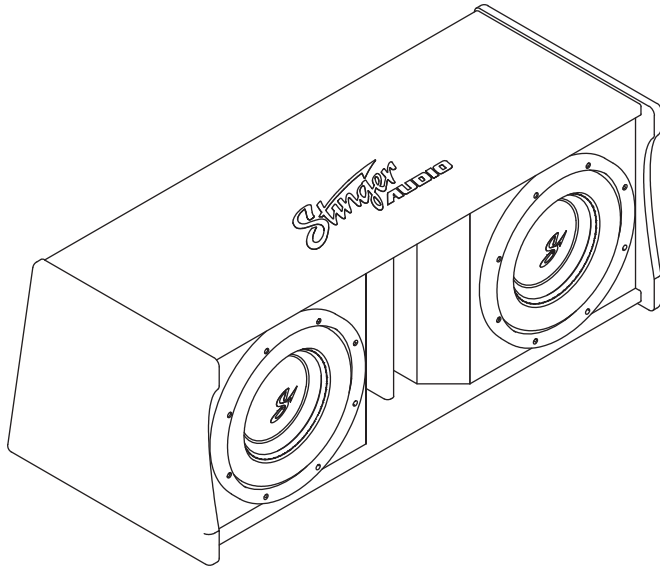

### FEATURES / SPECS

Woofer Size	10"
Speakers Per Box	2
Frequency Response	25Hz - 250Hz
Sensitivity	87 dB
Enclosure Type	Slot Ported
Enclosure Material	3/4" MDF
Finish	Black Carpet Carbon Vinyl
Width	34.1"
Height	14.2"
Depth 1 (Bottom)	17.9"
Depth 2 (Top)	16"
Weight	104 lbs
Connector Type	Spring-posts
RMS Power	2000W
Peak Power	3000W
Final Impedance	1 $\Omega$
Tuning Frequency	35Hz

### INSTALLATION TIPS

- ▶ Speaker Wire: 16-12 Gauge
- ▶ Amplifier: 1500-2000 Watts / 1 ohm Stable
- ▶ Subsonic Filter should be set to 30Hz !
- ▶ Ensure the speaker wires are connected correctly: Positive to Positive / Negative to Negative.
- ▶ The enclosure can be placed with the speakers facing forward, backward, upward or downward. Try each position to determine which direction sounds best in the vehicle.
- ▶ Once positioned, the enclosure should be securely anchored.

**WARNING:**

Stinger Audio products are capable of producing sound levels that can permanently damage your hearing! Listen responsibly and avoid continuous exposure to high sound pressure levels. While driving, keep the volume at a level that allows you to hear outside warning sounds (sirens, horns, etc.)

**LIMITED WARRANTY:**

Stinger warrants this product to be free of defects in materials and workmanship for a period of one (1) years from the original date of purchase. This warranty is not transferable and applies only to the original purchaser from an authorized Stinger dealer in the United States of America only. Should service be necessary under this warranty for any reason due to manufacturing defect or malfunction, Stinger will (at its discretion), repair or replace the defective product with new or remanufactured product at no charge. Damage caused by the following is not covered under warranty: accident, misuse, abuse, product modification or neglect, failure to follow installation instructions, unauthorized repair attempts, misrepresentations by the seller. This warranty does not cover incidental or consequential damages and does not cover the cost of removing or reinstalling the unit(s). Cosmetic damage due to accident or normal wear and tear is not covered under warranty.

**INTERNATIONAL WARRANTIES:**

Products purchased outside the United States of America are covered only by that country's Authorized Stinger reseller and not by Stinger. Consumers needing service or warranty information for these products must contact that country's reseller for information.



**Please DO NOT return to seller**

For help with installation, replacement parts, warranty or returns, please contact us directly at 727-732-3114 or [support@stingerelectronics.com](mailto:support@stingerelectronics.com)  
MON-FRI 9AM-5PM EST

