

King Kone

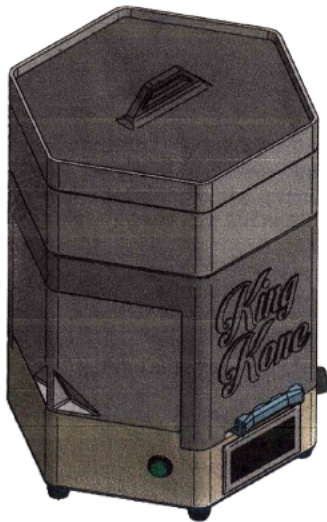

Using the machine:

The machine produces strong sequential impulses to give you the best pre-rolled cone pack. To produce optimum results and avoid machine damage, always use machine on a flat, level, sturdy surface. Always plug the machine into a protected and regulated outlet, never leave machine on while not in use and never leave unit unattended during use. *6 month warranty excludes damage from misuse outside intended operation demonstrated in this manual.

DISCLAIMER

The statements made regarding these products have not been evaluated by the Food and Drug Administration. The efficacy of these products has not been confirmed by FDA-approved research. These products are not intended to diagnose, treat, cure or prevent any disease. All information presented here is not meant as a substitute for or alternative to information from healthcare practitioners. Please consult your healthcare professional about potential interactions or other possible complications before using any product. The Federal Food, Drug and Cosmetic Act requires this notice. Neither the Company nor its representatives is providing any medical advice, and none should be inferred, from any ideas, suggestions, testimonials or other information set forth on this website or in other Company materials or provided over the phone, in the mail, in product packaging, or in email correspondence. Our website may contain links to third-party websites. The Company provides these links as a convenience only and does not endorse any of these sites. The Company is not responsible for the content of, and does not make any representations regarding the materials on, such linked third-party websites. If you decide to access or rely on information at linked third-party website, you do so at our own risk. These products are not for use by or sale to persons under the age of 18. Our terms and conditions, including disclaimers, are more fully set forth in our Terms of Use, Privacy Policy and Terms of Online Sales

WARNING: This product can expose you to chemicals including arsenic, which is known to the State of California to cause cancer. For more information, go to www.P65Warnings.ca.gov.

For Wholesale Pricing

NOT DISHWASHER SAFE

www.MJWholesale.com 1-844-398-4463

STEP 1: BASIC ASSEMBLY

Place the Small Size Cone Base on top of the Stand. If packing King size cones then place the King Size Cone Base on top of the Small Size Cone Base.

NOTE: In the case of a 3 piece cone base configuration, the cone bases should be in order from bottom to top as follows: BOTTOM, SHORT CONE, then KING CONE

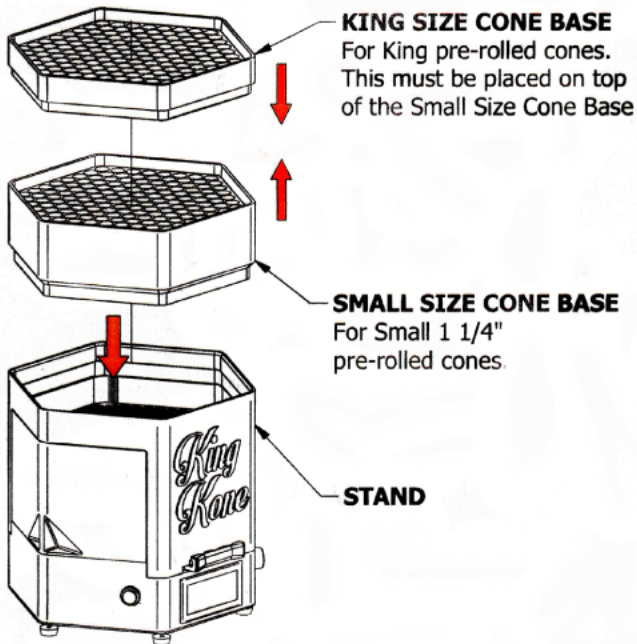

STEP 2: LOADING

A. Insert pre-rolled cones into cone openings so they are sitting on top of the Cone Platform surface.

B. Once all pre-rolled cones are loaded, turn on the machine to a 18 or 19 setting so the machine is actively moving up and down. Slowly sift material evenly over the top of the cone base until all cones are filled almost to the brim of the cone base. This process will run for approximately two minutes depending on the density and consistency of material.

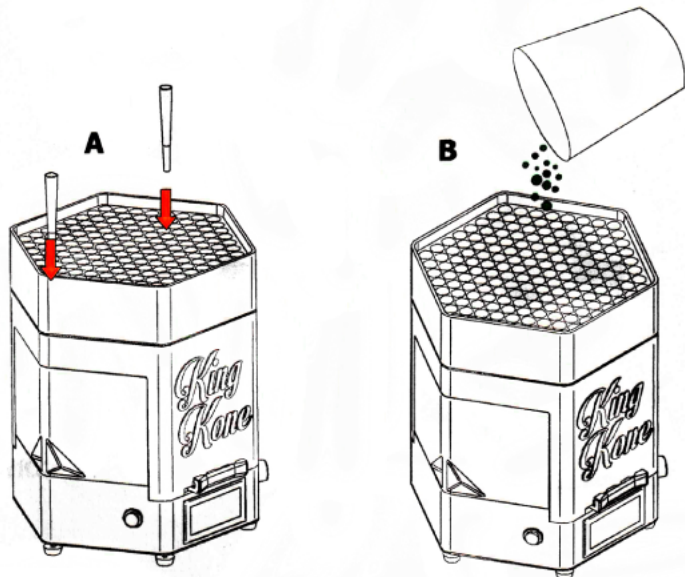

STEP 3: OPERATION AND REMOVAL

A. Once the material has been evenly spread over all cone holes so the top level of material settles approximately 1/4" below the top surface of the cone plate, apply the cone base Lid and turn the dial up to approximately 24. Let run for approximately 3 minutes or until the material is slightly below the top of the pre-rolled cone paper.

NOTE: Every material is different in consistency in which some require a longer or shorter duration run time and speed number setting to achieve the desired packing results. These run time and speed settings also differ between the Small Size Cone Base and King Size Cone Base, whereas the King Size is expected to require a higher number setting due to increased material weight.

B. Turn the machine off and remove Lid, then lifting from the bottom of the Cone Base, remove from the Stand and gently place on a clean surface. This will cause the filled cones to protrude out from the top so final twisting can be performed.

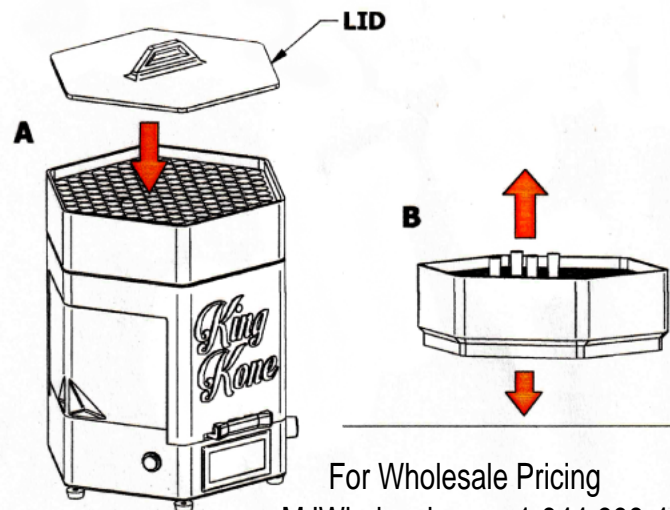

For Wholesale Pricing
www.MJWholesale.com 1-844-398-4463

STEP 4: CLEANING

Unlock and remove Stand from the Base, both Collection Trays and Cone Platform. Using a small stiff brush, sweep away any left over material from the Cone Platform, Docking Platform and other areas where needed.

Note: Collection Trays can be pulled out for cleaning without having to remove the Stand from the Base.

