

# FUTUROLA SHREDDER

## OPERATING INSTRUCTIONS

REMOVE **PIN & LID**

ROTATE **BARREL** UPRIGHT TO LOAD MIX

REPLACE **PIN & LID**

PLUG IN **SHREDDER** AFTER LOADING MIX\*

PRESS **SET** ON **TIMER** TO EXIT STANDBY MODE

MODIFY TIME INTERVAL WITH ▲ & ▼ BUTTONS

PRESS **SET** AGAIN TO RUN **SHREDDER**

UNPLUG **SHREDDER** BEFORE UNLOADING MIX\*

POSITION MIX CONTAINER BENEATH **SHREDDER**

REMOVE **PIN & LID**

ROTATE **BARREL** DOWN TO UNLOAD MIX

## MAINTENANCE

PERIODICALLY DUST **BARREL & MOTOR** WITH CANNED AIR

USE AMMONIA-FREE CLEANER ON **LID**

CLEANSE **BARREL** WITH ALCOHOL BEFORE STORAGE



LOADING POSITION



SHREDDING POSITION



UNLOADING POSITION

\*ALWAYS UNPLUG **SHREDDER** BEFORE LOADING/UNLOADING MIX AND WHEN NOT-IN-USE

# PRODUCT SPECIFICATIONS + LIMITED WARRANTY

## FULL VIEW

- 1 LID
- 2 BARREL
- 3 WHEELS
- 4 PIVOT STAND
- 5 MOTOR HOUSING
- 6 PIN
- 7 TIMER



## INSIDE BARREL

- 1 LID
- 2 SHAFT
- 3 WHIPS

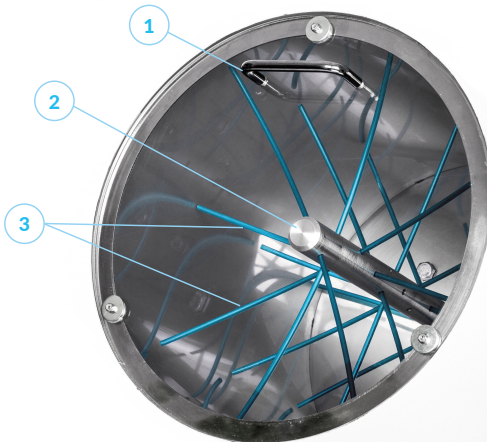

PART	MATERIALS + SPECIFICATIONS
DIMENSIONS	W: 26.5"   H: 55" IN LOADING POSITION   L: 28-25"
WEIGHT	85 LBS
STEEL	STAINLESS STEEL #304, FOOD-GRADE
SHAFT	STAINLESS STEEL #304, FOOD-GRADE
WHIPS	NYCAST® 6PA-NATURAL NYLON 6, FOOD-GRADE
TIMER	115V-230VAC, UL APPROVED
MOTOR	120/220, 6 AMP, UL APPROVED
CORD	16/3 SJTW 13AMP-25V, WATER/FLAME RESISTANT, UL APP.

## WHAT DOES THIS LIMITED WARRANTY COVER?

THIS LIMITED WARRANTY COVERS ANY MATERIAL OR MECHANICAL DEFECTS UNDER NORMAL USE DURING THE WARRANTY PERIOD. DURING THE WARRANTY PERIOD, AT THE FULL DISCRETION OF FUTUROLA USA, LLC, WE MAY CHOOSE TO REPAIR OR REPLACE, AT NO CHARGE, PRODUCTS OR PARTS OF A PRODUCT THAT PROVES DEFECTIVE BECAUSE OF IMPROPER MATERIAL OR WORKMANSHIP, UNDER NORMAL USE AND MAINTENANCE. THIS LIMITED WARRANTY EXTENDS TO THE ORIGINAL PURCHASER ONLY AND IS NON-TRANSFERABLE.

## HOW LONG DOES THE COVERAGE LAST?

THE WARRANTY PERIOD FOR A SHREDDER PURCHASED FROM FUTUROLA USA, LLC AND AUTHORIZED DISTRIBUTORS IS 365 DAYS FROM THE DATE OF PURCHASE. A REPLACEMENT SHREDDER OR PART ASSUMES THE REMAINING WARRANTY OF THE ORIGINAL SHREDDER OR 365 DAYS FROM THE DATE OF REPLACEMENT OR REPAIR, WHICHEVER IS LONGER.

## WHAT DOES THIS LIMITED WARRANTY NOT COVER?

THIS LIMITED WARRANTY DOES NOT COVER ANY PROBLEM THAT IS CAUSED BY: CONDITIONS, MALFUNCTIONS OR DAMAGE NOT RESULTING FROM DEFECTS IN MATERIAL OR WORKMANSHIP CONDITIONS, MALFUNCTIONS OR DAMAGE RESULTING FROM NEGLIGENCE, IMPROPER MAINTENANCE OR MODIFICATION. DAMAGED OR DESTROYED BY NATURAL CAUSES INCLUDING BUT NOT LIMITED TO LIGHTNING, FLOOD, OR OTHER NATURAL DISASTER. THEFT OR LOSS OF THE SHREDDER. THIS LIMITED WARRANTY DOES NOT COVER ANY SHIPPING CHARGES, HANDLING CHARGES, OR TAXES. YOU ARE RESPONSIBLE FOR AND MUST PREPAY ALL SHIPPING CHARGES. YOU SHALL ASSUME ALL RISK OF LOSS OR DAMAGE TO THE SHREDDER WHILE IN TRANSIT TO AND FROM FUTUROLA USA, LLC. THIS LIMITED WARRANTY IS VOID IF THE SHREDDER IS RETURNED WITH REMOVED, DAMAGED OR TAMPERED LABELS OR ANY ALTERATIONS.

## WHAT DO YOU HAVE TO DO?

TO OBTAIN WARRANTY SERVICE, YOU MUST CONTACT US TO REPORT THE CLAIM. WARRANTY SERVICE WILL BE FULFILLED AT THE DISCRETION OF FUTUROLA USA, LLC.

DELIVER THE SHREDDER, IN ITS ORIGINAL PACKAGING, INCLUDING ANY ACCESSORIES OR DOCUMENTS THAT SHIPPED WITH THE SHREDDER TO THE ADDRESS SPECIFIED BY FUTUROLA USA, LLC.

FUTUROLA USA, LLC WILL REFUSE THE RETURN OF SHREDDERS WHICH ARE NOT PROPERLY CLEANED OF ALL DEBRIS.

**TO REPORT A WARRANTY CLAIM, YOU CAN CONTACT US BY ANY OF THE FOLLOWING CONTACT METHODS:**

- BY PHONE: +1-310-258-9982
- BY EMAIL: SHREDDER@FUTUROLAUSA.COM

## IMPLIED WARRANTIES

EXCEPT TO THE EXTENT PROHIBITED BY APPLICABLE LAW, ALL IMPLIED WARRANTIES (INCLUDING WARRANTIES OF MERCHANTABILITY AND FITNESS FOR A PARTICULAR PURPOSE) SHALL BE LIMITED IN DURATION TO THE DURATION OF THIS LIMITED WARRANTY.

## LIMITATION OF DAMAGES

EXCEPT TO THE EXTENT PROHIBITED BY APPLICABLE LAW, FUTUROLA USA, LLC SHALL NOT BE LIABLE FOR ANY INCIDENTAL, INDIRECT, SPECIAL, OR CONSEQUENTIAL DAMAGES RESULTING FROM ANY BREACH OF EXPRESS OR IMPLIED WARRANTY OR CONDITION, OR UNDER ANY OTHER LEGAL THEORY.

## GOVERNING LAW

THIS LIMITED WARRANTY SHALL BE GOVERNED BY THE LAWS OF CALIFORNIA, USA WITHOUT GIVING EFFECT TO ANY CONFLICT OF LAWS PRINCIPLES THAT MAY PROVIDE THE APPLICATION OF THE LAW OF ANOTHER JURISDICTION.