

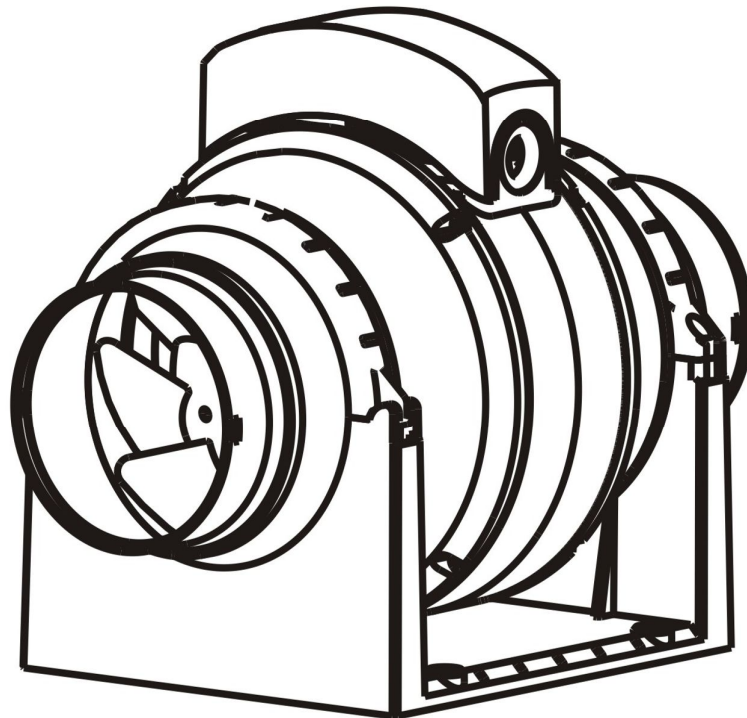

INSTALLATION AND WIRING INSTRUCTIONS

Mixed-Flow Ventilation Fan (Inline Exhaust Fan)



Model: XFLO100S XFLO100T
 XFLO125S XFLO125T
 XFLO150S XFLO150T
 XFLO200S XFLO200T

READ AND SAVE THESE INSTRUCTIONS

Model: Mixflow in-line Exhaust Fan

The unit is a mixed flow **range** in-line duct exhaust fans have been manufactured in accordance with the rigorous standards of production as defined by the International Quality Standards ISO 9001. All the components have been checked and tested at the end of the manufacturing process.

We recommend that you check the following after receiving this product:

1. The correct size has been received
2. The correct model has been received
3. The details on the rating label correspond to the electrical supply: voltage, frequency etc.

Remove the unit from packaging and inspect for shipping damage upon receiving this exhaust fan. If the product is found to be damaged, immediately contact your local authorized supplier.

DO NOT OPERATE THE UNIT IF DAMAGED.

ENVIRONMENT

This exhaust fans is suitable for operation within indoor environments only.

This fan is suitable for the exhaust or supply of both conditioned and un-conditioned airstreams within the temperature ranges (inclusive of duct airstream's temperature) of (-10°C up to +50°C).

ELECTRICAL EQUIPMENT SAFETY **PLEASE READ BEFORE USE**

WARNING: TO REDUCE THE RISK OF FIRE OR ELECTRIC SHOCK, OR INJURY TO PERSONS, OBSERVE THE FOLLOWING:

(a) Use this unit only in the manner intended by the manufacturer. If you have any questions contact the manufacturer.

(b) This appliance is not intended for use by persons (including children) with reduced physical, sensory or mental capabilities, or lack of experience and knowledge, unless they have been given supervision or instruction concerning use of the appliance by a person responsible for their safety. Children should be supervised to ensure that they do not play with the appliance.

-
- (b) Before servicing or cleaning the unit, switch the power off at the service panel and lock the service disconnecting means to prevent power from being switched on accidentally. When the service disconnecting means cannot be locked; securely fasten a prominent warning device such as a tag to the service panel.
- (c) Installation work and electrical wiring must be done by a qualified person(s) in accordance with all applicable **National** codes & standards including National Build code of Location.
- (d) Sufficient air is needed for proper combustion and exhausting of gases through the flue (chimney) of fuel burning equipment to prevent back drafting. Follow the heating equipment manufacturer's guideline and **latest** safety standards such as **the Build Code of Location**.
- (e) When cutting or drilling into wall or ceiling, do not damage electrical wiring and other hidden utilities.
- (f) Ducted fans must always be vented to the outdoors.
- (g) If this unit is to be installed over a tub or a shower, it must be installed in accordance with the Location National Wiring Rules.
- (h) Never place a switch where it can be reached from a tub or shower.
- (i) **CAUTION: For General Ventilating Use Only. Do Not Use To Exhaust Hazardous Or Explosive Materials and Vapours.**
- (j) **CAUTION: MOUNT WITH THE LOWEST MOVING PARTS AT LEAST 2.3 M ABOVE THE FLOOR OR GRADE LEVEL.**
- (k) All units are suitable for use with solid-state speed control.

This exhaust fan can be mounted in any orientation, horizontal or vertical, and is suitable for numerous types of applications.

See **Figure (4)** Illustration of some typical applications.

If the installation is made to rigid or flexible ducting, then we would recommend the correct diameter ducting is used to couple to the fan flanges. If it is necessary to bend the duct at the discharge of the fan, then the bend radius should be as large as possible.

Before installing the product check the following points: (1) the fan impeller turns freely and (2) there are no obstructions to the airflow.

All models include a robust mounting bracket which enables easy and quick installation of the fan. Duct work connection should be made with duct tape or duct fast-clamps (available through your local distributor or hardware retail store) to ensure a good seal and secure connection.

INSTALLATION

Installation tips:

This exhaust fan can be mounted in any orientation, horizontal or vertical, and is suitable for numerous types of applications.

See **Figure(1)** Illustration of some typical applications and mounting possibilities.

If the installation is made to rigid or flexible ducting, then we would recommend the correct diameter ducting is used to couple to the fan flanges. If it is necessary to bend the duct at the discharge of the fan, then the bend radius should be as large as possible.

Ductwork connection should be made with duct tape or duct fast-clamps (available through your local distributor) to ensure a good seal and secure connection.

Figure 1. Typical Applications:

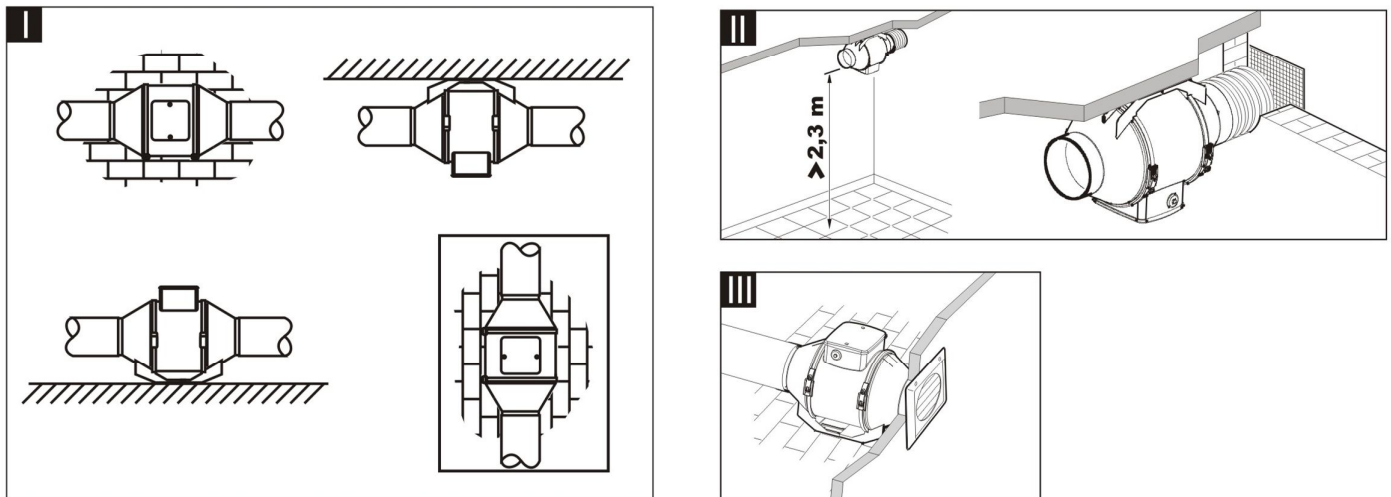

Multi-Point Exhaust System

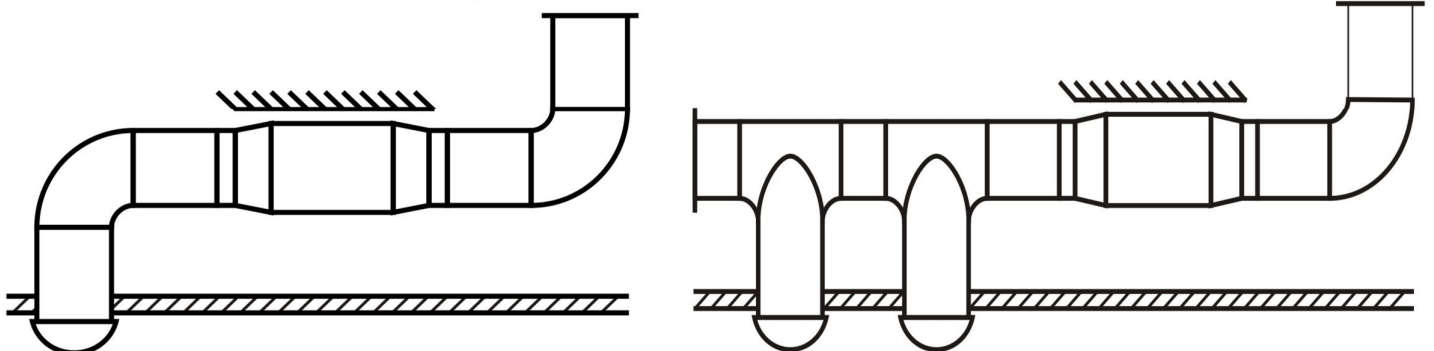
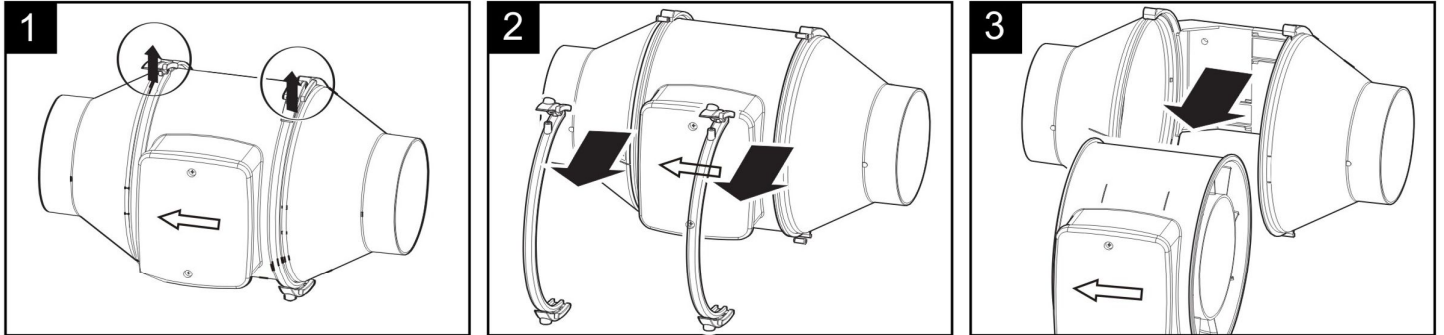
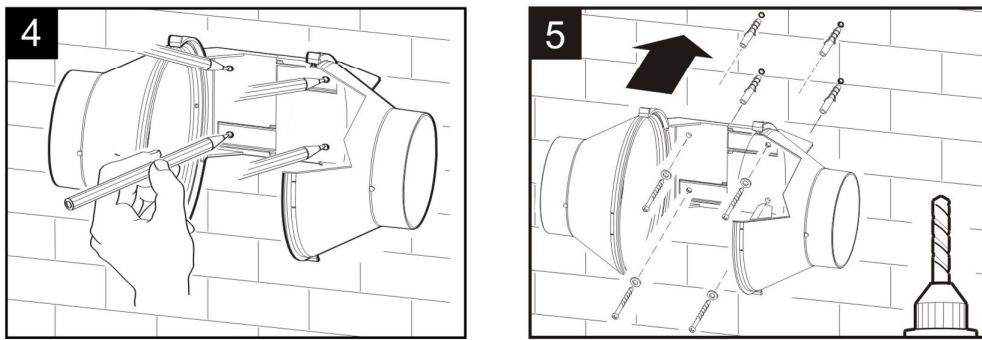

Figure 3. Installing and Assembly:

To start the installation the motor wheel assembly must first be removed, by loosen the two spring clips around the casing and remove. **(Step 1-3 diagram below).**



2. Secure the mounting bracket fan flange assembly to a fixed structure. **(Step 4-5 diagram below).**



3. Replace the fan motor wheel assembly and tighten the two spring clips to secure the product. **(Step 6-8 diagram below).**

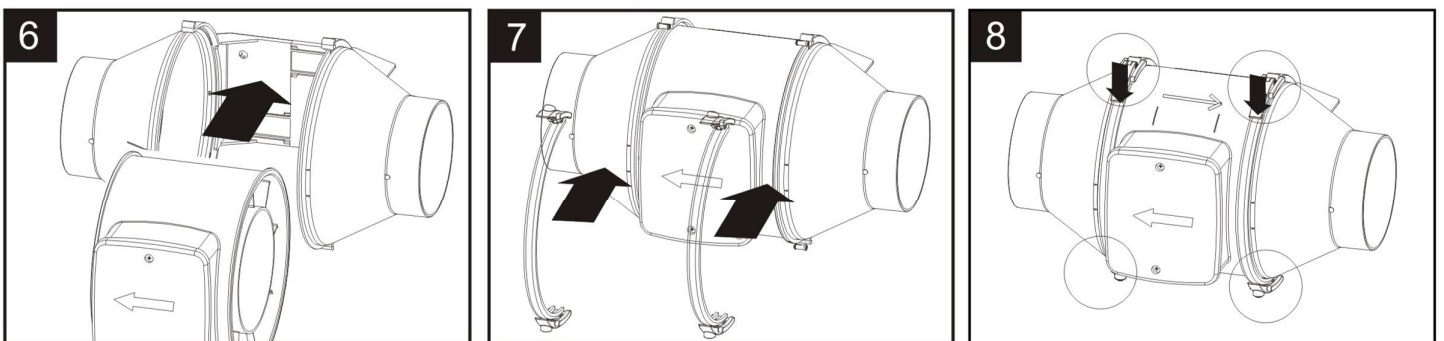

Note: Please pay attention to the Air Direction when replacing the motor wheel assembly.

4. Prepare the electrical wiring connection. Please refer to ELECTRICAL CONNECTION section of this manual for wiring diagram. **(Step 9-12 diagram below).**

Warning: All electrical connections and disconnections must be performed by a Licensed Electrician.

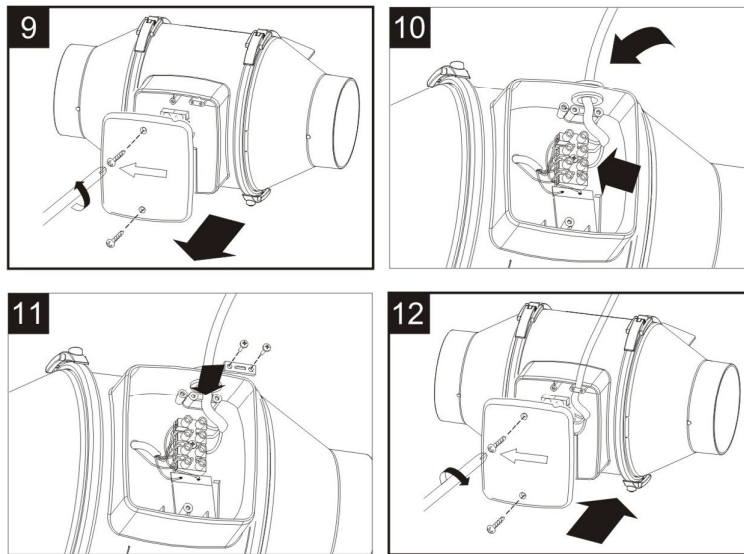

ELECTRICAL CONNECTION

This exhaust fan operates from a standard 220-240V 50Hz A.C electrical supply. All wiring must be carried out in accordance with National Wiring Code and all applicable state and local buildings codes.

Electrical connections should be made in accordance with the following diagrams: **Figure (4) Electrical Wiring.**

Figure 4. Electrical Wiring:

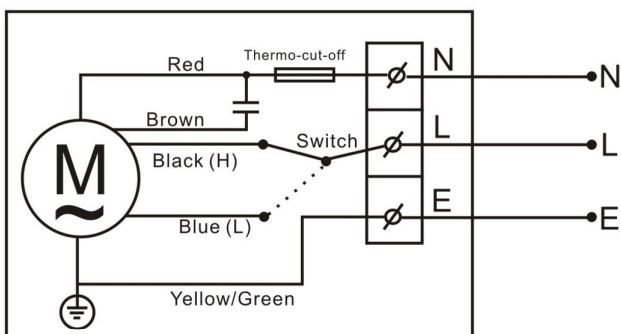

XFLO100S/XFLO125S
XFLO150S/XFLO200S

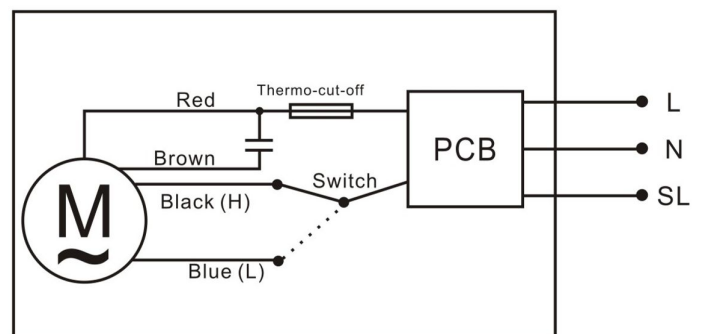

XFLO100T/XFLO125T
XFLO150T/XFLO200T

IMPORTANT:

ALL PRODUCTS INCORPORATE TWO SPEED(220-240V AC 50Hz) MOTORS.THE LIVE SUPPLY MUST ONLY BE MADE TO TERMINAL Hi OR Lo-NOT TOGETHER. THE USE OF A 3-POSITION SWITCH (NOT INCLUDED) WOULD ALLOW THE MOTOR TO OPERATE Hi/Lo/OFF.

IMPORTANT: An additional all pole disconnection switch **MUST** be included in the fixed wiring to provide isolation for maintenance.

MAINTENANCE

IMPORTANT: BEFORE CARRYING OUT ANY MAINTENANCE OR SERVICING, ENSURE THE UNIT IS DISCONNECTED FROM THE MAIN ELECTRICAL SUPPLY.

This exhaust fans incorporate sealed for life bearings and therefore do not require any lubrication . We would recommend inspection of the product at least once every twelve (12) months to avoid the excessive accumulation of dust and dirt on the impeller.

To inspect the unit disconnect from electrical supply and remove from ducting. If any debris is evident on the impeller clean with a damp (not wet) cloth. DO NOT USE any detergents or abrasive materials for cleaning.

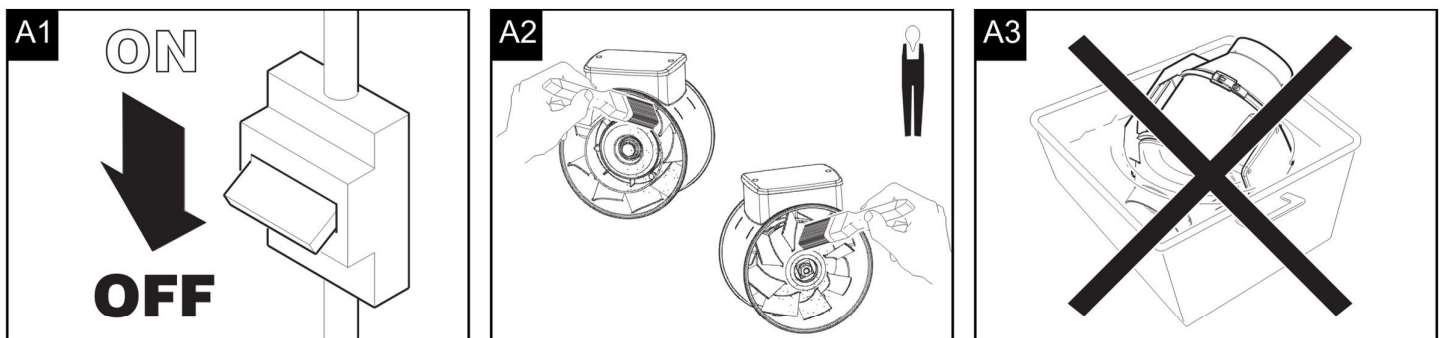

HOW TO OPERATING FUNCTIONS OF THE TIMER

Please no/off with the switch, Fan switches off immediately when the overrun time expires after the switch has been operated.

Overtime: approx. 1... 25 min.(Knob:A)

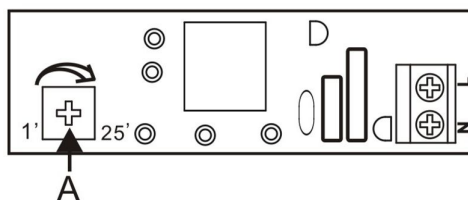

Rated input Voltage:	220-240V AC	220-240V AC	220-240V AC	220-240V AC
Model:	XFLO100S/ XFLO100T	XFLO125S/ XFLO125T	XFLO150S/ XFLO150T	XFLO200S/ XFLO200T
Rated Motor Power:	24/30Watts	26/33Watts	40/50Watts	100/130Watts
Rated Frequency:	50Hz	50Hz	50Hz	50Hz
Input / Output Ducted Dia.:	96mm(For 100mm ducting tubing)	121mm(For 125mm ducting tubing)	145mm(For 150mm ducting tubing)	198mm(For 200mm ducting tubing)
Max. Air Flow Rate:	180/250 CBM/h	220/330 CBM/h	370/530 CBM/h	700/820 CBM/h
Electrial Classification:	Class 1	Class 1	Class 1	Class 1
IP Rating (Ingress Protection Rating)	IPX4	IPX4	IPX4	IPX4
Indoor / Outdoor Suitability:	For Indoor use only	For Indoor use only	For Indoor use only	For Indoor use only
Climatic Classification:	Tropical condition	Tropical condition	Tropical condition	Tropical condition

