

OFF-ROAD MOTORCYCLE

USER MANUAL



Operation of this motorcycle by children under the age of 14 increases the risk of severe injury or death.

Adult supervision required for children under age 16.

NEVER permit children under age 14 to operate this motorcycle.

TABLE OF CONTENTS

	Page
PREFACE	1
INSTRUCTION FOR ASSEMBLING.....	2
USER MANUAL.....	4
TECHNICAL SPECIFICATIONS.....	4
UNPACKING AND SETTING UP BEFORE RIDING.....	5
BEFORE STARTING THE ENGINE.....	5
ENGINE STARTING.....	6
RIDING.....	7
PERIODIC MAINTENANCE CHART.....	7
SPARK ARRESTER.....	8
DRIVE CHAIN ADJUSTMENT	8
CENTRIFUGAL CLUTCH REPLACEMENT.....	9
FRONT AND REAR BRAKE ADJUSTMENT.....	9
WHEEL REMOVAL.....	9
TYPE CHANGE.....	10
AIR FILTER CLEANING.....	10
STORAGE PROCEDURE.....	10
TROUBLE SHOOTING.....	10
DESCRIPTION.....	11
PARTS LIST.....	12
EMISSION CONTROL SYSTEM WARRANTY.....	13
ELECTRICAL CIRCUIT DIAGRAM.....	15
PRODUCT WARRANTY.....	16

Table of maintain card

User name:			
Date of purchase		Tel	
Address:			
Dealer		Item name	
Item model		Signature	
VIN No.		Engine No.	

Product warranty

Thank you for purchasing our product.

To assure the highest level of service, please carefully read used manual and keep it after you had purchased the product.

Note:

Please finished all information on table of maintain card which must be authorized by the dealer. If you don't have invoice or copy of invoice that the warranty period will be run date of production.

Product warranty period: 6 months from the date of delivery. Unlimited mileage.

These items and conditions which excluded specifically:

- 1, Damage caused by accidents, misuse, negligence, improper vehicle operation.
- 2, Any modification or alteration to any standard specifications or equipment.
- 3, Any repairs made by an unauthorized dealer or service firm,
- 4, Use of no genuine parts for repairs or alteration to standard specifications.
- 5, Damage which occurs as a result of improper storage.
- 6, Damage caused by the use of improper fuel or lubricants, and/or failure to use proper oil/gas mixture on two stroke models.

The following normal wear parts are specifically excluded from warranty coverage:

- 1, Plastic body
- 2, Tire
- 3, Chain
- 4, Brake disc , brake pad
- 5, Clutch
- 6, Spark plug

PREFACE

Thank you for choosing off-road motorcycle. May you enjoy riding all time. This manual contains the necessary instructions and guidance with respect to the operation and maintenance of motorcycle, and **BE SURE TO READ IT CAREFULLY BEFORE YOU RIDE THE MOTORCYCLE; AND BE SURE TO PAY MORE ATTENTION TO THE WARNING WORDS AND INSTRUCTION WHEN RIDING.** Illegal operation motorcycle can result in **SEVERE INJURY or DEATH.** Proper operation and maintenance can guarantee a safe riding to minimize trouble of the motorcycle and keep it in a sound condition, which can extend the engine service life.

The vehicle is designed to be driven on closed tracks with an even, smooth, and dust-free surface or designated area. This product is not designed to be used on public roads. Both adults and person over 14years old can ride the vehicle (younger than 16 under the supervision of an adult/responsible person.) This Product is not designed for rough terrain. It is equipped with a single-cylinder, four-stroke, petrol combustion engine with an air filter and exhaust silencer. The vehicle has front and rear disk brake, controlled by the brake lever on the handlebars.



Safety warning:

User must read this manual carefully.

The rider's age must be 14 or over 14 years old, supervise riders younger than 16.

Forbid to drive when you don't know well of this motorcycle.

Forbid to lend it to people who don't know the vehicle.

It is designed for OFF-ROAD or designated area use.

It carry rider only. Never carry passenger.

Always wear a helmet and other protective gear.

INSTRUCTION FOR ASSEMBLING

WARNING

Set-up and pre-delivery service must be performed by an authorized luyuan dealer. Proper pre-delivery is essential to reliability of the vehicle and to rider safety. Perform all items correctly and completely. Observe all safety precautions and use common sense when assembling this vehicle. Avoid contact with moving parts. Severe personal injury to the person assembling this vehicle or to a bystander could result.

- ▲ In order to perform service work efficiently and to prevent costly errors, Must thoroughly familiarize with procedures before beginning. A knowledge of mechanical theory, tool use and shop procedures is necessary to perform the service work safely and satisfactory
- ▲ Watch for sharp edges which can cause personal injury. Protect hands with gloves when working with sharp components.
- ▲ If difficulty is encountered in removing or installing a component, look to see if a cause for the difficulty can be found. If it is necessary to tap the part into place, use a soft face hammer and tap lightly.
- ▲ Cleanliness of parts and tools are as well as the work area if of primary importance. Dirt and foreign matter will act as an abrasive and cause damage to precision parts.

1.open the carton ,take out the motorcycle

2.setting up the front tyre
need tools:wrench



The front axle should be passed through 2,3, tire,4 and 5. Then will be fastened by nut 1,6

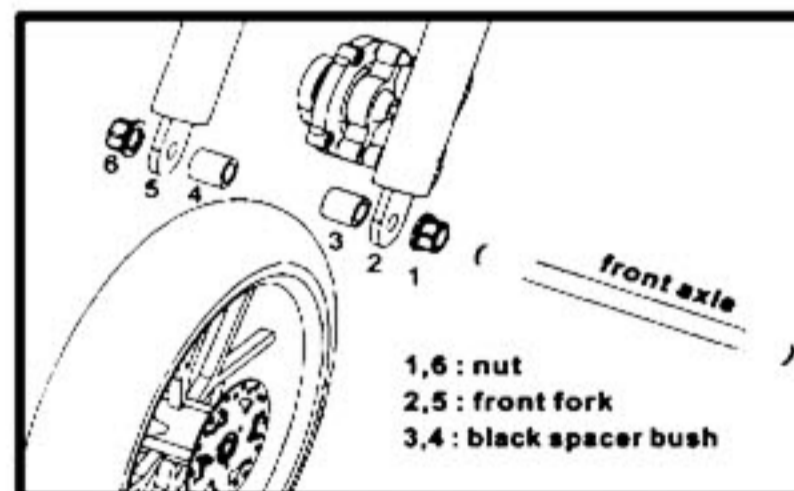

ELECTRICAL CIRCUIT DIAGRAM

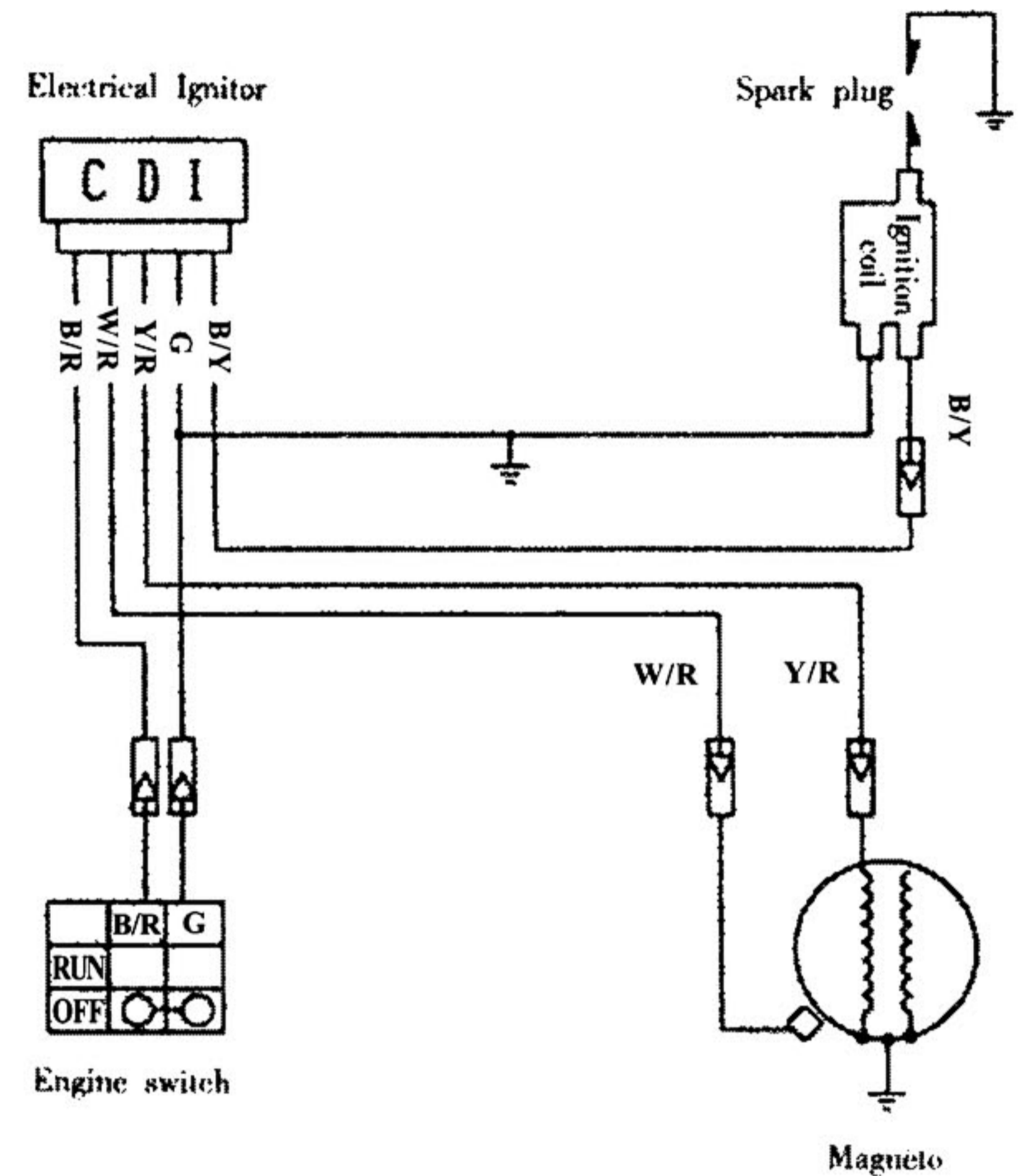

- (2) misuse,
- (3) repairs improperly performed or replacements improperly installed,
- (4) use of replacement parts or accessories not conforming to LUYUAN,INC's specifications which adversely affect performance and/or
- (5) use in competitive racing or related events.

- B. Inspections, replacement of parts and other services and adjustments required for required maintenance.
- C. Any vehicle equipped with an odometer or hour meter on which the odometer mileage or hour meter reading has been changed so that actual mileage cannot be readily determined.

III. Limited Liability

- A. The liability of LUY under this Emission Control System Warranty is limited solely to the remedying of defects in material or workmanship by an authorized LUY dealers at its place of business during customary business hours. This warranty does not cover inconvenience or loss of use of the vehicle or transportation of the vehicle to or from the LUYUAN INC's dealers. LUY SHALL NOT BE LIABLE FOR ANY OTHER EXPENSES, LOSS OR DAMAGE, WHETHER DIRECT, INCIDENTAL, CONSEQUENTIAL OR EXEMPLARY ARISING IN CONNECTION WITH THE SALE OR USE OF OR INABILITY TO USE THE LUYUAN VEHICLE FOR ANY PURPOSE. SOME STATES DO NOT ALLOW THE EXCLUSION OR LIMITATION OF ANY INCIDENTAL OR CONSEQUENTIAL DAMAGES, SO THE ABOVE LIMITATIONS MAY NOT APPLY TO YOU.
- B. NO EXPRESS EMISSION CONTROL SYSTEM WARRANTY IS GIVEN BY LUY EXCEPT AS SPECIFICALLY SET FORTH HEREIN. ANY EMISSION CONTROL SYSTEM WARRANTY IMPLIED BY LAW, INCLUDING ANY WARRANTY OF MECHANABILITY OR FITNESS FOR A PARTICULAR PURPOSE, IS LIMITED TO THE EXPRESS EMISSION CONTROL SYSTEM WARRANTY TERMS STATED IN THIS WARRANTY. THE FOREGOING STATEMENTS OF WARRANTY ARE EXCLUSIVE AND IN LIEU OF ALL OTHER REMEDIES. SOME STATES DO NOT ALLOW LIMITATIONS ON HOW LONG AN IMPLIED WARRANTY LASTS SO THE ABOVE LIMITATIONS MAY NOT APPLY TO YOU.
- C. No dealer is authorized to modify this LUY Limited Emission Control System Warranty.

IV. LEGAL RIGHTS. THIS WARRANTY GIVES YOU SPECIFIC LEGAL RIGHTS, AND YOU MAY ALSO HAVE OTHER RIGHTS WHICH VARY FROM STATE TO STATE.

V. THIS EMISSION CONTROL SYSTEM WARRANTY IS IN ADDITION TO THE LUY STANDARD LIMITED WARRANTY FOR ALL ATVs.

VI. ADDITIONAL INFORMATION. Any replacement part that is equivalent in performance and durability may be used in the performance of any maintenance or repairs. However, LUY is not liable for these parts. The owner is responsible for the performance of all required maintenance. Such maintenance may be performed at a service establishment or by any individual. The warranty period begins on the date the motorcycle is delivered to an ultimate purchaser.

LUYUAN,INC

Address: 19295 EAST WALNUT DR. NORTH # E CITY OF INDUSTRY, CA 91748

3.setting up the rear suspension
need tools:wrench

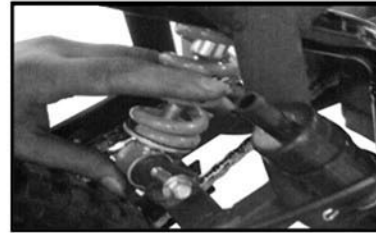

4.setting up handle bar
need tools: hexagram



5.setting up the front fender
need tools:hexagram



6.setting up front cover



7. stick the label



8.test drive

ATTN: fill the fuel tank with gas, and start the pull start to test drive to check

USER MANUAL

1. Make sure to put on safety helmet and some other necessary safeties before driving the motorcycle, and abide by local road code.
2. Make sure there is enough oil in the fuel tank before driving. Press the switch, open the oil stop, and pull the line of pull start to startup the motorcycle.
3. Please careful to using the handle accelerograph. The motorcycle will run faster when the accelerograph is bigger given. When turning left or right, pls pay attention to your speed. The right handle control the front disc brake, and the left handle control the rear disc brake. In the right handle, there is a button, used for stopping the motorcycle. When you press the button, the motorcycle will stop immediately.
4. If you want to stop the engine working, pls press this switch.

 **Warning:** user must abide by the local road code and the safety statute.

Technical specifications

Item No.	LY40MT-1
ENGINE	one cylinder, four-stroke, air-cooled
DISPLACEMENT	40cc
POWER OUTPUT	0.9kw at 6000rpm
TORQUE	1.6Nm at 5000rpm
STARTER SYSTEM	manual-hand pull type
FRAME	welded high strength steel tubes
BRAKE	front and rear disk
FRONT TYRES	12 1/2 x 2.75
REAR TYRES	12 1/2 x 2.75
FUEL TANK CAPACITY	1.8L
WEIGHT	46LBS
WEIGHT(Incl packing)	55LBS
CARRYING CAPACITY	165LBS
DIMENSIONS	1070x550x710mm
BOX PACKING DIMENSIONS	990x 302x582mm

LUYUAN, INC-EMISSION CONTROL SYSTEM WARRANTY STATEMENT

YOUR WARRANTY RIGHTS AND OBLIGATIONS

The U.S. Environmental Protection Agency, and LUYUAN, INC (hereinafter "LUY") are pleased to explain the emission control system warranty on 2014 Off-Road Motorcycle New off-road motor vehicles must be designed, built and equipped to meet U.S. EPA Federal anti-smog standards. LUY must warrant the emission control system on your vehicle for 30 months or 5,000 km, whichever comes first, provided that there has been no abuse, neglect or improper maintenance of your vehicle.

Your emission control system may include parts such as the carburetor or fuel injection system, the ignition system, catalytic converter and engine computer, if it is equipped. Also included may be hoses, belts, connectors and other emission-related assemblies.

Where a warrantable condition exists, LUY will repair your vehicle at no cost to you, including diagnosis, parts and labor.

If an emission-related part on your vehicle is defective, the part will be repaired or replaced by LUY. This is your emission control system DEFECTS WARRANTY.

NOTICE! Use of any LUYUAN vehicle in any type of competitive event completely and absolutely voids this and all other warranties offered by LUY.

OWNER'S WARRANTY RESPONSIBILITIES

As the vehicle owner, you are responsible for the performance of the required maintenance listed in your owner's manual. LUY recommends that you retain all receipts covering maintenance on your vehicle, but LUY cannot deny warranty solely for the lack of receipts or for your failure to ensure the performance of all scheduled maintenance.

You are responsible for presenting your vehicle to the LUY dealers as soon as a problem exists. The warranty repairs should be completed in a reasonable amount of time, not to exceed 30 days.

As the vehicle owner, you should be aware that LUY may deny your warranty coverage if your vehicle or a part has failed due to abuse, neglect, improper maintenance or unapproved modifications.

If you use your vehicle in any type of competitive event, this warranty is immediately and completely void. If you have any questions regarding your warranty rights and responsibilities, you should contact LUYUAN, INC at 19295 EAST WALNUT DR. NORTH # E CITY OF INDUSTRY, CA 91748, Tel: 626-839-8839

LUY warrants that each new 2014 and later LUYUAN OFMC:

- A. is designed, built and equipped so as to conform at the time of initial retail purchase with all applicable regulations of the United States Environmental Protection Agency; and
- B. is free from defects in material and workmanship which cause such vehicle to fail to conform with applicable regulations of the United States Environmental Protection Agency for the periods specified above.

I. Coverage. Warranty defects shall be remedied during customary business hours at any authorized LUY dealers located within the United States of America in compliance with the Clean Air Act and applicable regulations of the United States Environmental Protection Agency. Any part or parts replaced under this warranty shall become the property of LUY.

II. Limitations This Emission Control System Warranty shall not cover any of the following:

- A. Repair or replacement as a result of
 - (1) accident,

PARTS LIST

ITEM NO.	NAME	ITEM NO.	NAME
1	frame	20	rear brake handle
2	rear damping	21	throttle limiter handle
3	rear fork	22	throttle limiter
4	chain shield	23	handle bube
5	rear wheel	24	handle cover
6	rear jack	25	front brake handle
7	chain wheel	26	left handle
8	kickstand	27	fuel cover
9	footrest	28	seat
10	chain	29	plastic cover
11	engine	30	aluminium plate
12	switch of fuel tank	31	filter
13	gear case	32	oil tube
14	front brake	33	rear brake
15	front brake disc	34	rear brake clamp
16	front wheel	35	rear brake disc
17	front damping	36	air filter
18	front fender	37	carburetor
19	label	38	pull starter

UNPACKING AND SETTING UP BEFORE RIDING

Your off-road motorcycle is packed with folded handlebars and brake lever. After unpacking, first set up the tyres, then set up the handlebar to a comfortable position. After setting-up the handlebars, tighten the handlebar bolts (M6), the brake lever bolt, and the throttle grip bolt according to Fig. 1. While tightening the bolts, do not use an excessive force. Over tightening the bolts may cause damage of the threads or other parts. Verify the smooth and free movement of both control cables (throttle and brake).

Fig. 1



BEFORE STARTING THE ENGINE

Before operating this vehicle, be sure to check the items in the following table:

ITEM	ROUTINE
Fuel	*Check fuel level in fuel tank ,and add recommended fuel if necessary *check fuel line for leakage. Correct if necessary
Engine oil	*Check oil level in engine ,and add recommended oil to specified level if necessary *Check OFMC for oil leakage. Correct if necessary
Front brake	*Check operation ,and correct if necessary *Lubricate cable if necessary *Check lever free play, an adjust if necessary
Rear brake	*Check operation ,and correct if necessary *Lubricate cable if necessary
Throttle lever	*Make sure that operation is smooth, and check cable free day *Lubricate cable and lever housing if necessary
Wheels and tires	*Check wheel condition, and replace if damaged *Check tire condition and tread depth. Replace if necessary *Check air pressure, correct if necessary
Brake levers	*Make sure that operation is smooth. lubricate lever pivoting points if necessary
Chassis fasteners	*Make sure that nuts, bolts and screws are property tightened
Instruments and switches	*Check operation ,and correct if necessary

ENGINE STARTING

(Fig 2).

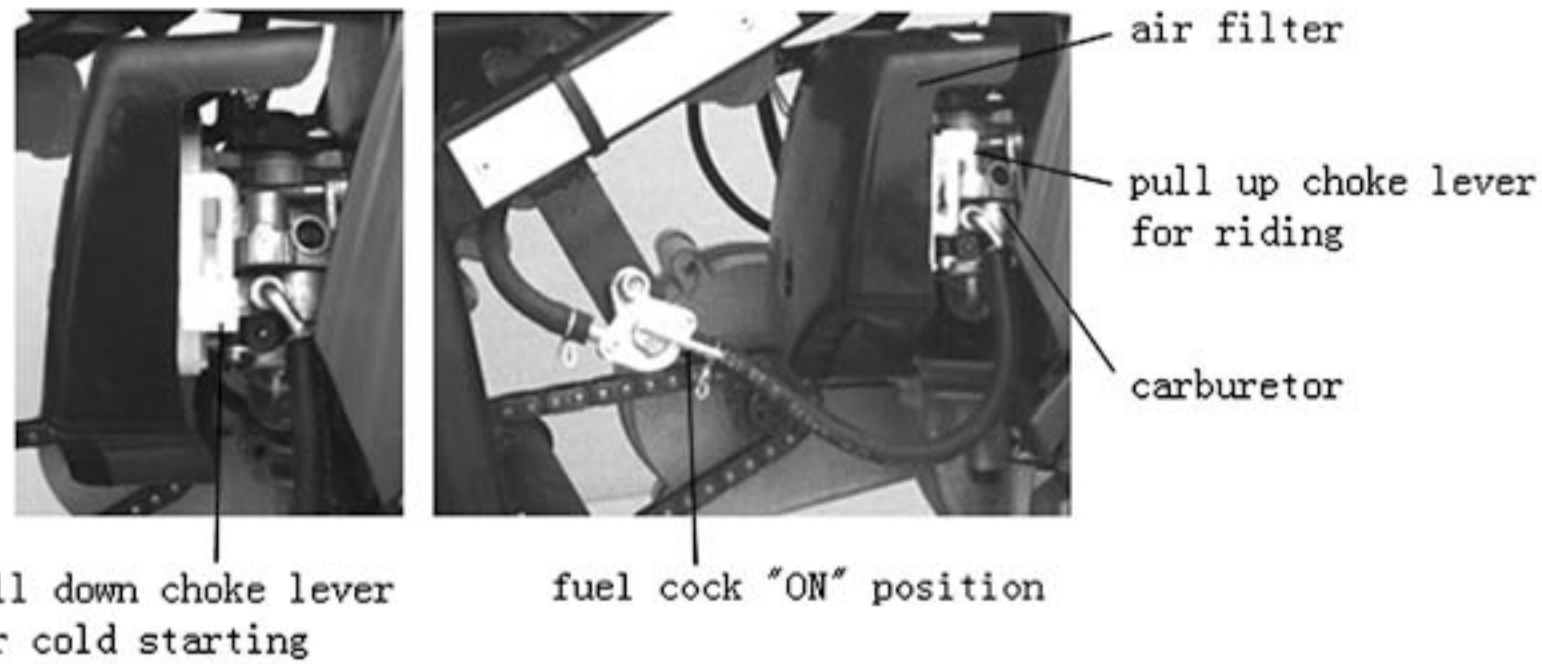

Fill the fuel tank with gasoline and refit the fuel cap. Open the fuel cock, turning it to the position "ON", Fig 2. Pull down the choke lever, gently pull the starter rope twice and then on the third pull, the engine should start, Fig. 3. Do not pull the starter rope out completely! After a short period, pull up the choke lever, let the engine run to normal operation temperature.

Fig. 3

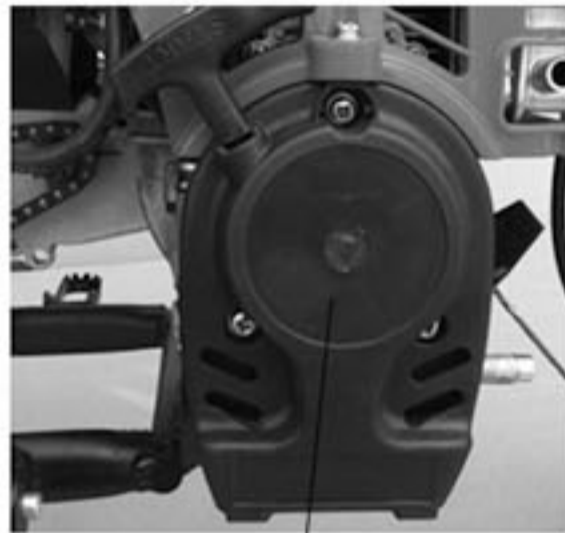

Pull starter

Fuel and fuel vapour are highly toxic and flammable. Always be careful when handling fuel—it can burn or poison you.

- stop the engine and turn off the fuel tap, keep naked flames and sparks away from your vehicle.
- do not smoke near your vehicle.
- refuel only outdoors in a well ventilated space.
- clean up any excess fuel immediately.
- keep children and pets away.

DESCRIPTION

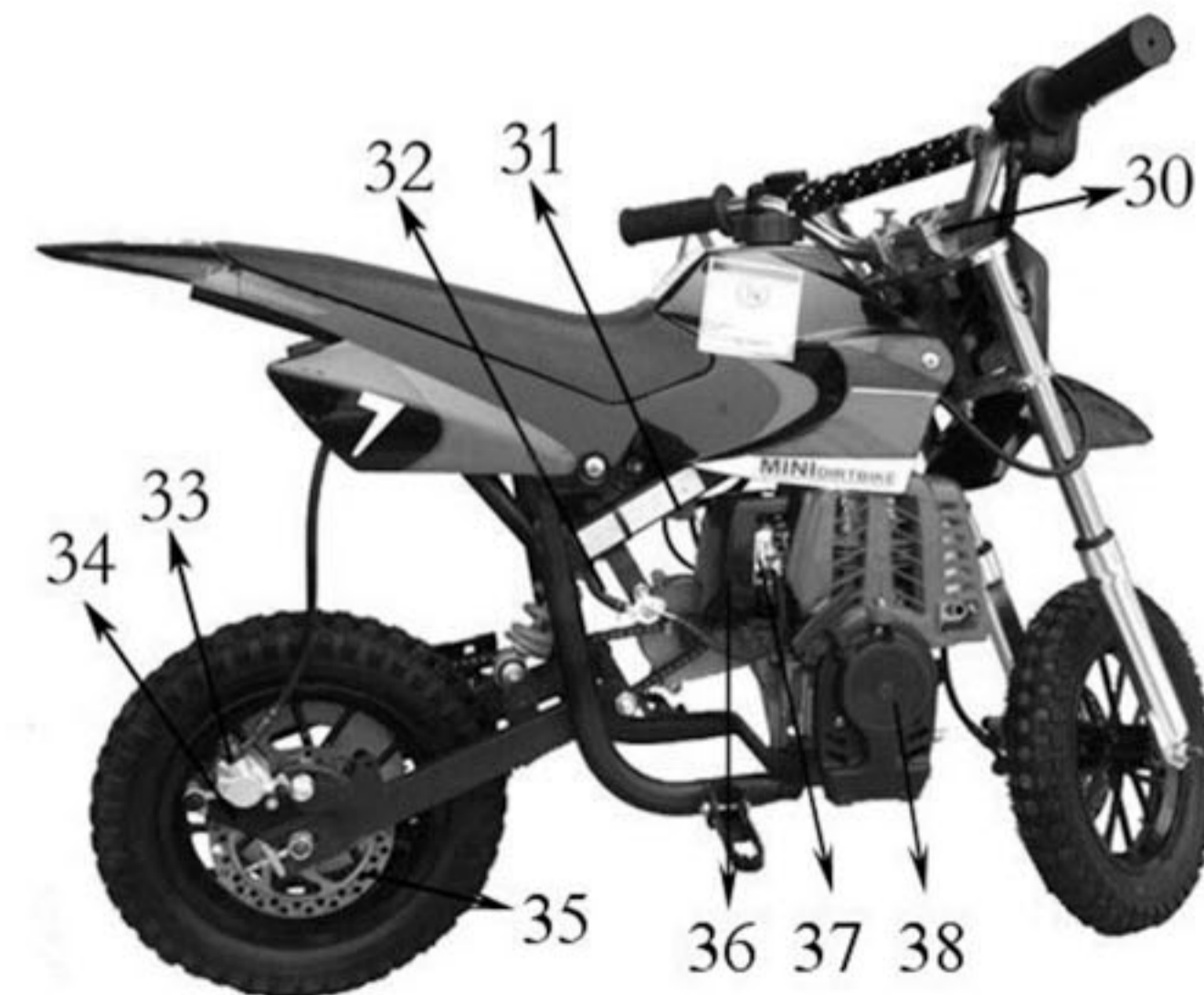

TYRE CHANGE

Remove the wheel (see above) deflate the inner tube. Detach both halves of the wheel rim by removing the 3*M6 fixing bolts (M6). Then replace the tyre and or inner tube. To re-assemble reserve the above making sure not to trap the inner tube and locate the valve correctly also note the tyre direction.



Using worn, improperly inflated, or incorrect tyres will reduce stability and can cause an accident.

AIR FILTER CLEANING

Loosen 2pcs sleeve screw (see Fig. 2) so you can easily remove the Air filter cover. Now you have free access to filter. Remove the filter, clean it in petrol and lubricate it with engine oil. To re-install the filter, reverse the procedure above.

STORAGE PROCEDURE

If the vehicle is to be left unused for a period of time, it is recommended to drain out all the fuel from the fuel tank and carburetor. Inflate the tyres to the normal working pressure. Remove the spark plug, clean it, put a few drops of motor oil into the cylinder, pull the starter rope 2-3 times, so an oil film evenly coats the cylinder walls and piston. Re-install the spark plug.

TROUBLE SHOOTING

1. FUEL

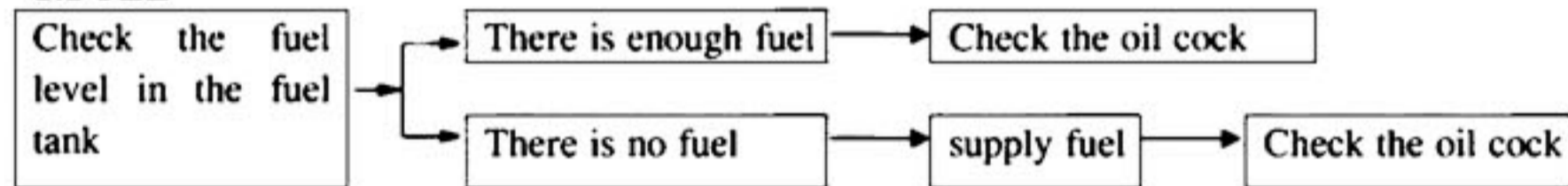

2. Carburetor

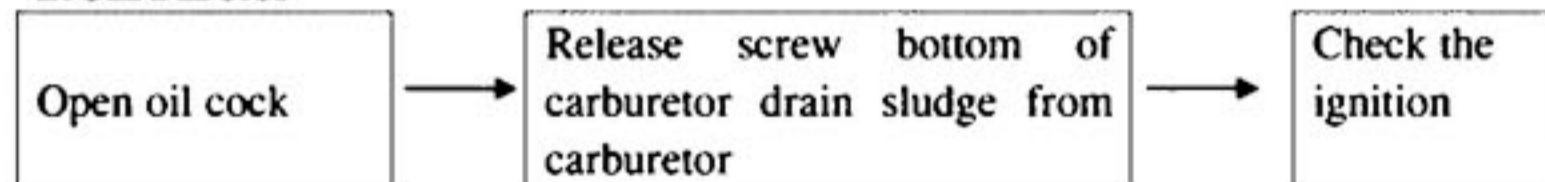

3. Ignition

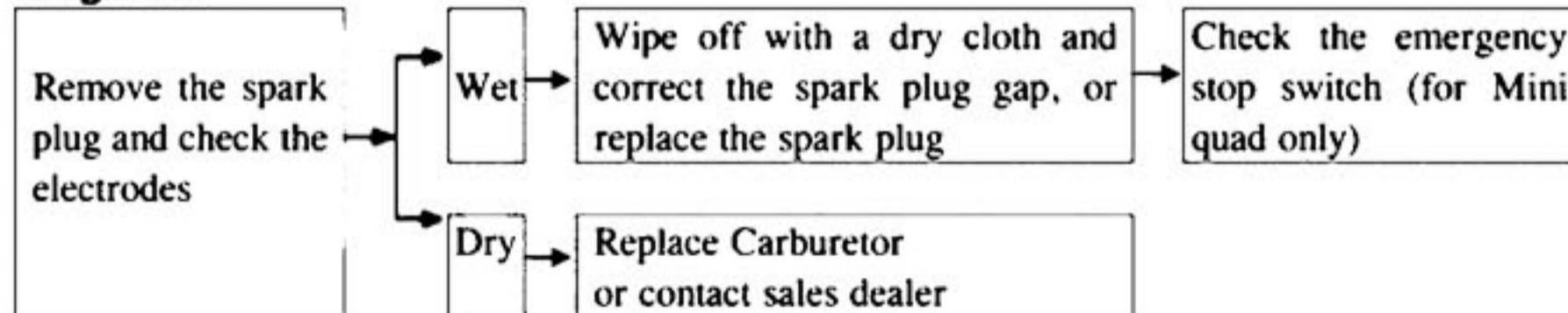

4. Emergency stop switch

check the emergency switch, make sure the cap fasten seated.

RIDING

Sit on the vehicle and slowly twist the throttle to start moving forward. sit on the front part of the seat; do not lean back, try to keep the load of your body as forward as possible. Reduce speed accordingly when going around corners.

When braking, always reduce the throttle to the idle position whilst pressing the front or rear break lever with the necessary force to stop the vehicle. Turn the engine off with the button (engine kill stop switch) ON THE HANDLEBARS (Fig. 1).

It is necessary to check the tightness of bolts and nuts, including the engine, and the brake settings, before and after every use.



Always ride within the limits of vehicle/rider and weather conditions to avoid unnecessary accidents and injuries.

PERIODIC MAINTENANCE CHART

perform all services at whichever maintenance interval is reached first

maintenance interval		Every time using	First month or 10 hours	Total 3 month or 25 hours	Total 6 month or 50 hours	Total one year or 100 hours	Total 2 years or 300 hours
Engine oil	Check oil level	○					
	change		○				
air filter	Check clean	○		○ ①			
Spark plug	Check adjustment					○	
	Change						○
Spark arrestor	clean					○	
Idle speed	Check adjustment					○ ②	
radiator	Check clean				○		
Ignition Timing	Check						300 hour ②
Nut, bolts	Check fastening	○					
valve clearance	Check adjustment				○ ②		
Fuel filter	Check					○	
Tire pressure	Check	○	The normal presser is 69kpa .				
chain	Check	After every 100km riding, it is necessary to lubricate the chain by special oil for the sprocket.					
Brake pads	Check adjustment	it is necessary to change the seriously attrite brake pads to ensure the performance of braking..					

① If using the dust, need regular maintenance and replace felt.

② Unless the user has the appropriate tools and the maintenance ability, these items will be maintained need by dealers.

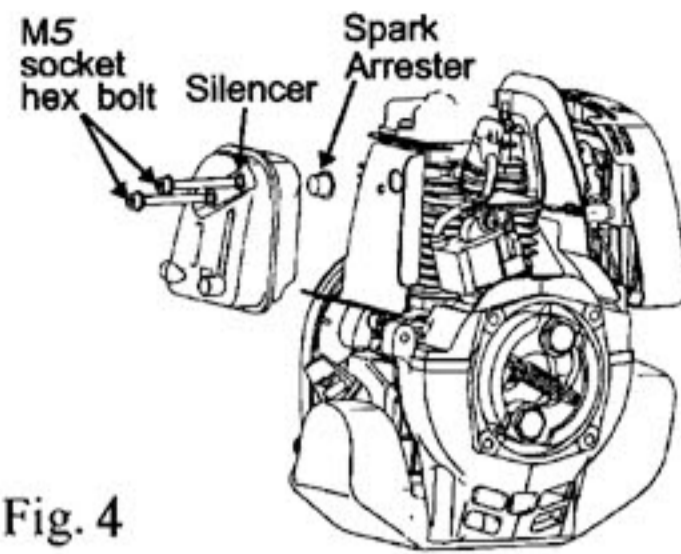

Fig. 4

SPARK ARRESTER

1. Loosen three cross recess-head combination screw M6 X16 to remove the air director.
2. Loosen socket hex bolts 2 X M5 to remove the silencer.
3. Brush away carbon depositions from the spark arrester guard. Be cautious not to damage the guard. There should be no crack or broken hole on the spark arrester. Replace if any problem is found.



The silencer will be very hot the moment the engine stops running. Operate after the engine is cooled down. The spark arrester must be turned up every 100 hours of operation to maintain its effectiveness.

DRIVE CHAIN ADJUSTMENT

Loosen the bolts (1) on the rear axle carrier also loosen (2) bolt on the rear brake to allow for tensioning or loosen the chain. the drive chain should be 5mm (0.2 in), making sure not to over tighten the chain, fasten the (1, 2) bolts to tighten.

It is important to lubricate the chain regularly to avoid excess wear. This will prolong the lifetime of the chain. It is important to lubricate the chain after every ride and especially in wet conditions. It is recommended to use a quality chain lubricant. If the chain needs replacement, then please also check the front and rear sprockets for wear, replace accordingly.

Fig. 5

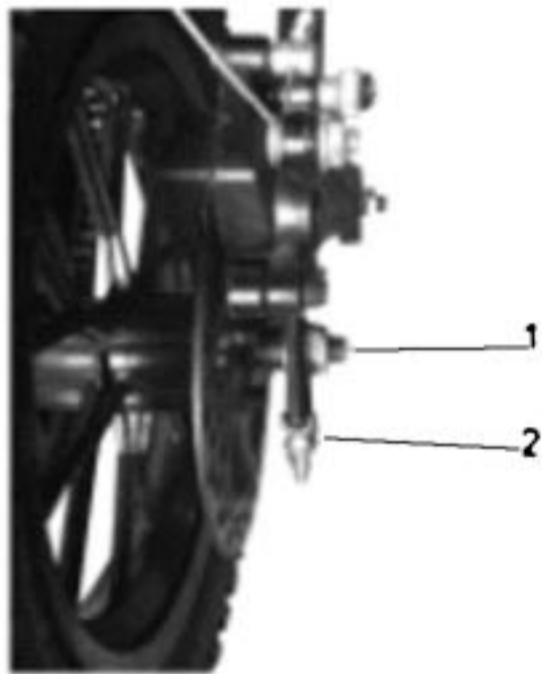

Riding with a chain in poor condition or improperly adjusted can lead to serious injury. Always, Inspect, Adjust and Maintain the drive chain properly before each ride.

CENTRIFUGAL CLUTCH REPLACEMENT

Remove the chain guard. Release the chain and dismantle it. Loosen the four bolts holding the cover of the clutch. Release the engine brace on the frame, and move to one side. Loosen the bolt of position A. the clutch will be broken away. Replace new clutch and install it. Then reverse the sequence as described, and readjust the tension of the drive chain.

Fig. 6



loosen front 4pcs screws

clutch pad A



The thickness of clutch pad must not be less than 1mm

FORNT AND REAR BRAKE ADJUSTMENT

Loosen 1 and 2 screw, left hand put up the brake frame, right hand tension brake cable to adjust.

Fig. 7

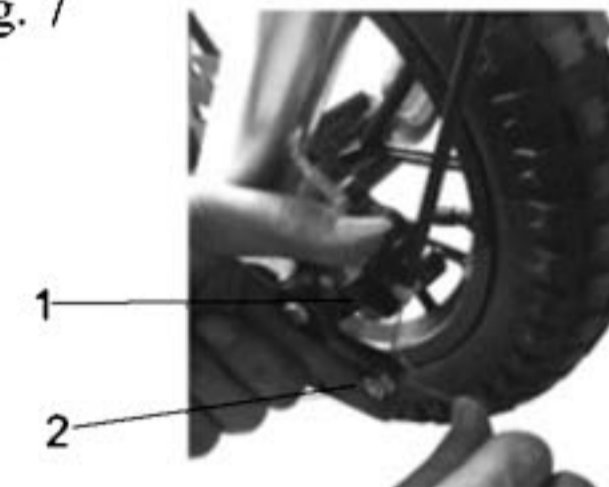

WHEEL REMOVAL

Loose left and right screw and draw out the axle, pull off the wheel. To re-install the wheel, reverse the sequence-install the wheel and tighten the axle nut securely.