

# E-Bike Owner's Manual



 **MONTAGUE**®



Even if you have ridden a bike for years, it is important for you and every rider to read this manual before riding this bicycle. Keep for reference.

# HELMETS SAVE LIVES!

Always wear a properly fitted helmet that complies with CPSC or CE safety standards when you ride your bicycle.



**Correct Fitting** - Make sure your helmet covers your forehead.



**Incorrect Fitting** - Forehead is exposed and vulnerable to serious injury.

## **WARNING**

As with all mechanical components, the bicycle is subjected to wear and high stresses. Different materials and components may react to wear or fatigue in different ways. If the design life of a component has been exceeded, it may suddenly fail possibly causing injuries to the rider. Any form of crack, scratch or change of colouring in highly stressed areas indicate that the life of the component has been reached and it should be replaced. Do not ride in an abusive manner.

## **CAUTION**

In this manual, the CAUTION sign shows a hazardous situation which, if not avoided, could cause minor or moderate injury.

## **WARNING**

In this manual, the WARNING sign shows a hazardous situation which, if not avoided, could cause death or serious injury.

## **WARNING**

Great care should be taken when locking the quick release levers on the bicycle. If you do not fully understand how to operate the quick release levers, ask a bicycle dealer for assistance, or call Montague's Customer Support Team at +1 617-491-7200.

**DO NOT RIDE YOUR BICYCLE WITHOUT ALL QUICK RELEASES SECURELY LOCKED.**

# TABLE OF CONTENTS

## Warnings 2

### Section One

<b>Introduction</b>	<b>4</b>
Record Your Serial Number	4
Register Your Bicycle	4
Owner's Responsibility	5
Bicycle Type and Use Conditions	6
E-Bike Classes	7
Product Symbols	7
Introduction to E-Bikes	8
Difference Between E-Bikes and Conventional Bikes	8
Kickstand and Cargo Rack	10
Child Seats and Trailers	10
Supplementary Manuals	10

## Parts of your Bicycle 11

### Before your First Ride 12

Sizing and Weight Limit	12
Electric Assist Operation	12
Check your Brakes, Steering, and Quick Releases	13
Prevent Toe Overlap	13
Moving Parts and Pinch Points	14
Frame or Fork Problem	14
Life Span of a Bicycle	14

### Before Every Ride 15

Mechanical Checklist	15
Drive-Assist System Checklist	15
Carbon Fiber Composite	15
Examine the Frame, Fork, & Wheels	17
Tire Inflation	17
Examine the Brakes and Steering	18
Saddle and Seatpost	19
Suspension and Quick Releases	19
Lights and Reflectors	19

### Riding Safely 20

Caution: Wet Weather Riding	21
Be Seen (Especially at Night)	21
Think Safety	22

### Riding Instructions 23

Using your Brakes	23
Changing Gears Correctly	23
Descending	24
Obstacles and Impacts	25

## Section Two

### Assembling your Bicycle 26

Packing List	26
Installing Front Wheel QR	26
Installing Front Wheel	27
Rotating Stem	28
Installing the Handlebars	30
Installing Front Fender	31
Attaching Steering Damper Spring	32
Installing the Seatpost	32
Installing Pedals	33
Inflating Tires	34

### Folding your Bicycle 35

Folding the Pedals	37
Rolling the Bike	38

### Unfolding your Bicycle 39

Adjusting the Frame Quick Release	40
-----------------------------------	----

### Drive Assist System 42

Rechargeable Battery	42
Charger and Power Supply	43
Tips for Getting the Most Range	45
Cleaning, Storing, and Transporting	46
Keys	48
Disposal	48

## Section Three

### Proper Maintenance and Adjustment 49

Torque Specifications	49
Handlebars	49
Stem	50
Seat (Saddle) Adjustments	51
Pedals	52
Control Cables	52
Rear Derailleur Adjustment	52
Front Derailleur Adjustment	53
Brakes	54
Wheels	55
Fitted Accessories	57
Bearing Adjustments	58
Lubrication	58

### Maintenance Schedule 61

### Warranty 62

### Registration Card Insert

# INTRODUCTION

This manual is designed to give you the information you need for the safe operation and maintenance of your new bicycle. Please read it thoroughly before riding your bicycle.

## **WARNING**

Make sure to read this complete manual before riding your bike. Failure to do so, or failure to follow its guidelines, could lead to serious injury or death.

**Section One** of this manual involves safety and bicycle care. Understanding and following this information will help you and your Montague bicycle avoid injury or damage.

**Section Two** of this manual covers specific operating instructions for your Montague bicycle. Even if you're an experienced rider, you should review this section before your first ride.

**Section Three** of this manual gives basic instructions for making small adjustments to your bicycle and performing regular maintenance.

## Record Your Serial Number

Model Name:	.....
Serial Number:	.....
Key Serial Number:	.....
Date of Purchase:	.....
Place of Purchase:	.....

Your bicycle's serial number is stamped on the seat tube of the frame, on the drive side of the bike (Fig. 1). Record the serial number in this manual below in the event that your bicycle is lost or stolen. You may also want to register your serial number with your local police department.

## Register Your Bicycle

Bicycle registration is the only record we have of who owns this bicycle. Registration and proof of purchase are necessary to make a warranty claim. There are two easy procedures to complete the registration (mail or email):

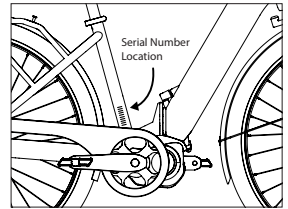

Fig. 1: The serial number is located on the seat tube of the frame on the drive-side.

- Fill in the registration form in the back of this manual and mail it to us.
- Go to [www.montaguebikes.com/register](http://www.montaguebikes.com/register) and submit the registration form to us via the internet.

The frequently updated website also gives you a link to new instructions. If you make a decision not to complete the registration, make sure you visit the website frequently.

Since the components on your Montague are industry standard, repairs or replacements may be performed at virtually any retail bicycle dealer.

If you have any questions about your Montague after reading this manual, or encounter any problems when folding or unfolding your bike, please visit the support section of our website at [www.montaguebikes.com/support](http://www.montaguebikes.com/support) or call Montague's Customer Support Team at +1 617-491-7200. A knowledgeable representative will be happy to answer any questions and help you to fully enjoy your new Montague.

## Owner's Responsibility

### **WARNING**

Make sure to read this complete manual before riding your bike. Failure to do so, or failure to follow its guidelines could lead to serious injury or death.

Before riding your Montague, carefully follow all assembly instructions.

Ensure your bike is the correct size for your comfort and safety. When standing over the frame (straddle frame) you should have a minimum of 1.0" clearance between the top tube and your body. See page 12 for more information.

**Note:** Montague does not make bicycles intended for children. Please make sure all riders are adults.

Bicycle riding can be a hazardous activity even under the best of circumstances. Proper maintenance of your bicycle is your responsibility as it helps reduce the risk of injury.

All quick releases must be securely fastened before riding any Montague bicycle. The quick releases are pictured on page 11 in Fig. 2. They are: the front wheel quick release (#25), the seat post quick release (#8), the frame quick release (#9), the rear wheel quick release (#32), and the stem quick release (#4). For instructions on operating the quick release levers, read *Assembling Your Montague Bicycle and Folding Your Montague Bicycle* on pages 26-37.

Double check to ensure all bolts and screws are tightened to the correct torque specifications.

Make sure anyone to whom you loan your Montague understands how to work the quick release levers and how to fold and unfold your Montague bike properly.

The owner is responsible for required normal maintenance services, such as those listed in the "Maintenance Schedule" section of this booklet (page 61) in order to keep the bicycle in good operating condition.

Damage or injury resulting from negligence, improper operation, improper or unauthorized repair or maintenance, environmental influences, or improper use are not warranted by Montague Corporation. Montague Corporation excludes incidental and consequential damages.

## Bicycle Type and Use Conditions

There are many types of bicycles. Each bicycle type is made for a specified use or use condition. If your use of a bicycle applies more stress than its condition limit specifies, this could cause a failure of the bicycle (or a part of the bicycle).

This section shows the use condition for different types of bicycles. If you are not sure of what condition(s) apply to your bike, consult your Montague dealer or call Montague for more information.

### Condition 1

These bicycles are made to ride on a paved surface where the tires are always on the ground.

Condition 1 bicycles typically feature flat or drop style handlebars and 700c wheels and smooth tires. These bicycles may have accessories such as a rack, fenders, or kickstand attached.

### Condition 2

Condition 2 bicycles are made to cover all the riding conditions expressed by

condition 1 with the addition of gravel roads and groomed off-pavement trails.

Condition 2 bicycles typically feature flat handlebars and 700c or 26" wheels. These bicycles have "semi slick" tires with light knobs on them and direct pull brakes.

### Condition 3

Condition 3 bicycles are made to cover all the riding conditions expressed by conditions 1 and 2 with the addition of rough trails, small obstacles, smooth technical areas, and areas where tires are momentarily not on the ground; NOT FOR JUMPS. These bicycles are typically referred to as Mountain Bicycles or Cross Country Mountain Bicycles.

Condition 3 bicycles typically feature flat handlebars and 26" or 27.5" wheels. These bicycles have wider tires with large knobs on them and direct pull or disc brakes.

## **WARNING**

If your use of a bicycle applies more stress than the specified use condition of the bicycle, the bicycle or its parts can be broken or damaged. Riding a bicycle that is damaged could decrease your control and cause you to fall. Do not ride in use conditions that apply more stress than the limits of the bicycle. If you are not sure of the limits of the bicycle, consult your dealer.

## E-Bike Classes

In the US, e-bikes can be categorized by a three-class system based upon their speed, wattage, and operation. In some regions, the class of your e-bike can determine which types of bicycle infrastructure it can be ridden on.

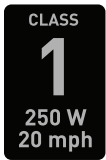

Class 1: E-bikes that are pedal-assist only, with no throttle, and have a maximum assisted speed of 20 mph. Your Montague e-bike falls under Class 1.

For reference:

Class 2: E-bikes that also have a maximum speed of 20 mph, but are throttle-assisted.

Class 3: E-bikes that are pedal-assist only, with no throttle, and a maximum assisted speed of 28 mph.

## Product Symbols

The following symbols are shown on packaging, the rechargeable battery, or the charger.



Marking for electrical devices that must not be disposed of in household or non-recyclable waste. Dispose of electrical devices with this marking at suitable collection points for environmentally friendly recycling.



Marking for single-use and rechargeable batteries that must not be disposed of in household or non-recyclable waste. Dispose of single-use and rechargeable

batteries with this marking at suitable collection points for environmentally friendly recycling.



Marking for materials that are hazardous to the environment. Take particular care when handling products with this marking. Observe disposal regulations.



Marking for recyclable materials. Sort packaging and dispose of separately. Dispose of cardboard along with waste paper and film in your recycling collection.



Marking for products that must only be used indoors.



Europe: The 230 V~/50 Hz mains power supply has a class II protection rating.

USA: The 120 V~/60 Hz mains power supply has a class II protection rating.



Symbol for direct current (DC).



Symbol for alternating current (AC)



Only applicable for Europe: Products marked with this symbol meet all applicable European Economic Community regulations.

## Introduction to E-bikes

Electric bikes, known as “e-bikes” or Pedelecs, are electric power-assisted bicycles (EPACs) which have an electric motor and battery operated drive system to provide pedal assistance up to a maximum of 20 mph (25 km/h) when the rider is pedaling and the bicycle is in motion.

The Montague ME-1 is a Class-1 e-bike which has a power rating of 250 Watts and provides assistance up to a maximum speed of 20 mph. In most countries, Class-1 e-bikes are legally classed as bicycles. Please familiarize yourself with the legal regulations and laws regarding e-bikes in your country, state and/or city and maintain a current knowledge as these regulations and laws are subject to change.

### **WARNING**

Please read all warnings carefully. Failure to operate the e-bike safely may result in serious injury or death to you and others.

## Differences between E-bikes and Conventional Bicycles

E-bikes ride differently from conventional bikes due to increased weight and speed. In addition to the list below, please review the Sections Before Your First Ride and the Riding Instructions in this manual.

The electric drive and increased speed requires practice and care while braking.

Braking while steering may reduce the ability to control your bicycle.

Due to the increased speed, braking may require more distance to stop. Pay attention to road conditions as sand, leaves, rain or other materials on the road may impact your ability to brake quickly.

- E-bikes require more braking force. This can increase wear on the brakes.
- Reduce pedal force before initiating a gear shift to reduce drivetrain wear.
- Pay attention to your speed going into a corner and be sure to stop pedaling before entering the corner. Otherwise, you may carry too much speed when entering a corner.
- Shift gears regularly to stay in an optimal cadence range and downshift before coming to a stop.
- Always keep both hands on the handlebars when riding the e-bike. Failure to do so may cause you to lose control of the e-bike and crash.
- Due to the greater acceleration of an electric bicycle, you should also pay particular attention to terrain conditions as you may approach obstacles faster than expected.

Riding faster increases the risks of serious accidents. Watch out for other vehicles, cyclists, pedestrians, and animals where you ride. Always operate under control and at a safe speed.



Other road users such as drivers, pedestrians and other cyclists may need to adjust to the higher speed of the e-bike and may not be aware of you. It is your responsibility to anticipate and react to avoid accidents.

## **WARNING**

**IT IS YOUR RESPONSIBILITY TO OPERATE YOUR E-BIKE IN A SAFE AND RESPONSIBLE MANNER.**

Always ride your e-bike under control and at a safe speed. Be aware of all other users of the road such as pedestrians, other cyclists, motorcycle, scooter, automobile and truck drivers and animals. Note that they may not see you due to their line of sight, or be expecting and able to react to the increased speed of the e-bike depending on the weight and type of vehicle. Be especially cautious while riding at night.

## **E-bikes are Heavier than Ordinary Bicycles**

Always park the bike in a suitable safe area away from children, cars or animals that may come into contact with it. In order to prevent possible injuries and damage to the e-bike, park it so that it cannot fall over. Use caution when handling the e-bike (including, but not limited to parking, lifting, pushing, loading it into a car or onto a bicycle carrier and unloading it).

## **Intended Use**

Your Montague e-bike is intended, designed, and tested for riding on paved surfaces, smooth gravel roads and improved trails with moderate grades where the tires do not lose ground contact.

Find out before your first ride whether your e-bike is equipped in accordance with requirements for use on the road. Note that national and regional regulations may vary.

Items that may have special requirements:

- Brakes
- Lighting and reflectors
- Bell or other approved warning device

Familiarize yourself with the legal regulations and laws regarding e-bikes in your country, state and/or city.

For example:

- Minimum rider age
- Compulsory insurance or if your insurance policy must provide coverage for accidents involving use of this e-bike. You should contact your insurance agent to determine if you need additional coverage.
- Operating licenses or whether registration of your e-bike is required
- Compulsory helmet use
- Use restrictions on public roads, cycling paths and/or trails

## **WARNING**

It is your responsibility to know and follow all local laws and regulations regarding use of your e-bike.

### Use of the Kickstand

The kickstand is not designed to support the weight of a person sitting on the e-bike. Make sure the kickstand is up before riding. Park your e-bike on a level, firm surface for the best support of your e-bike.

### Rear Cargo Rack

- The rear rack is designed to carry cargo secured in panniers or other containers.
- Never carry a passenger on the rack.
- The maximum allowable cargo weight for the rear rack is 55 pounds (25kg). Do not exceed this weight as it could cause a weight imbalance and could result in a loss of control and injury.

## **WARNING**

The weight carried on your rack can affect the handling of a bicycle by altering the center of gravity, weight and balance. Using your rack incorrectly can result in a loss of control, resulting in serious injury and/or death.

### Child Seats and Trailers

## **WARNING**

No child seats or trailers are allowed for use with your Montague electric bicycle.

### Drive System and Supplementary Manuals

Your e-bike includes additional user manuals for the various components on your bike. For full instructions on the operation and configuration of the drive-assist system and associated electronics, please read the included drive-assist manual.

Please familiarize yourself with the manufacturer's instruction for intended use or limitation. You are required to use your e-bike responsibly.

## **WARNING**

Do not ride the e-bike through deep water or submerge any part of the e-bike. If you do so, you could lose control of the e-bike or the drive system can become disabled or damaged.

## **WARNING**

Understand your e-bike, drive-assist system and the intended use of both. Using your e-bike the wrong way is dangerous and can lead to serious injury or death to you and others.

# PARTS OF YOUR BICYCLE

Fig 2. Parts of your e-bike and location of quick releases

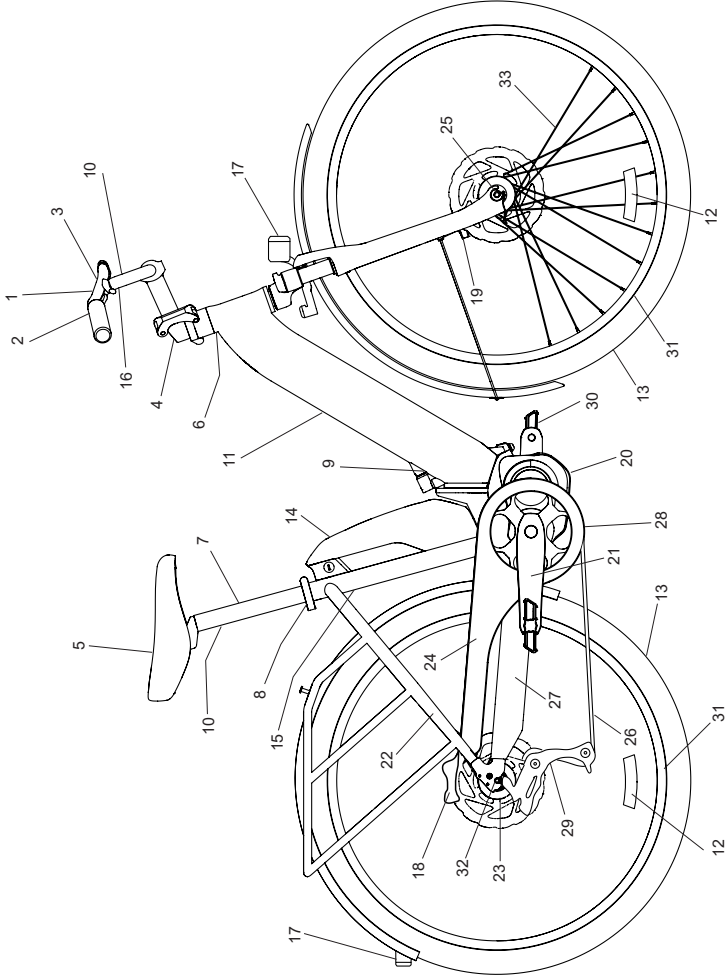

1. shift levers
2. handlebar
3. brake lever
4. stem
5. saddle
6. head set
7. seat post
8. seat post quick release
9. frame quick release
10. reflectors (front & rear)
11. down tube
12. spoke reflectors (front & rear)
13. tire (front & rear)
14. rechargeable battery
15. seat tube
16. control unit
17. lights (front & rear)
18. rear disc brake
19. front disc brake
20. drive unit (motor)
21. crank arm
22. seat stay
23. cassette
24. chain guard
25. front wheel quick release
26. chain
27. chainstay
28. chain wheel
29. rear derailleur
30. pedal
31. rim (front & rear)
32. rear wheel quick release or nut
33. wheel spokes

# BEFORE YOUR FIRST RIDE

## **WARNING**

A bicycle that does not work properly can cause you to lose control and fall. Inspect the entire bicycle thoroughly before every ride, and do not ride it until any problem has been corrected.

### **Make Sure your Bicycle is the Correct Size**

For a safe and comfortable ride, it is important to buy an e-bike with the right height and length of frame for the rider. The right frame height depends on the rider's inside leg (inseam) measurement. It is important to take the inside leg measurement into account so that it is possible to quickly and safely stop the cycle and dismount in dangerous situations. Consult a dealer about the right frame size.

The optimum seating position depends on the size and shape of the cycle frame, the size of the rider, and how the handlebars and saddle are adjusted. Optimum seating position adjustments require expertise. The optimum seating position can also depend on how the cycle is used, e.g. primarily for sports.

The main characteristics of an optimum seating position are:

- When one pedal is up, the arms and the top knee are all at a 90° angle.
- The lower leg is slightly bent.
- When one pedal is forward, the knee is over the axle of the front pedal.

- The arms are relaxed and bent slightly outwards
- The back is leant slightly forward, not vertical to the seat post.

You can adjust the saddle (pages 32 and 51) and handlebar (pages 30 and 50) to offer the best comfort and performance. Before you make these adjustments, refer to the Proper Maintenance and Adjustments section beginning on page 49.

### **Maximum Gross Weight Limit**

Montague bicycles are designed for a maximum total weight of rider plus luggage of 250lbs or a maximum total weight of rider plus luggage plus bicycle of 300lbs.

### **Know How your Bike Operates**

The elements of your e-bike, if not used correctly, can decrease your control of the e-bike. Before you ride fast or outside a controlled environment, learn the operation and performance of all the mechanisms of your e-bike. Practice using the various features of your e-bike at slower speeds in a flat, open area before taking the bike on public roads. If your e-bike does not operate correctly or as expected, or if different parts are necessary for the safe operation of your e-bike, speak to your dealer or call Montague Corporation +1 617-491-7200.

### **Electric Assist Operation**

Familiarize yourself with all aspects of the e-bike that are specific to electric

bicycles. Read the supplementary manuals to understand the power-assisted drive system and other components.

Before your first ride, you should use the lowest power ECO mode and become familiar with the operation of the electric bicycle by practicing starting and stopping, cornering and navigating obstacles in a safe environment away from other bicycles, pedestrians, and/or vehicles. Learn about the e-bike's controls and digital data/messaging.

## **WARNING**

Failure to practice riding your e-bike in a safe environment prior to riding on a public road or pathway with other users of the road may result in serious injury or death to you or other users of the road.

## **Check your Brakes, Steering, and Quick Releases**

Press each hand lever to ensure the brakes are moving freely and stop the bike. Braking performance changes with riding conditions. Practice braking at low speeds before taking your e-bike out into high traffic areas or trails. If your brakes are not working properly, **DO NOT** ride your e-bike. Take the e-bike to your local dealer for service.

Check that all quick releases (front wheel, frame, stem, seatpost, and rear wheel) are fastened. Nothing should rattle or be loose.

Review Riding Safely on page 20 and Riding Instructions on page 23 before attempting to ride your Montague e-bike. Check the steering as shown in Fig. 5, page 18.

## **Prevent Toe Overlap**

Some frame sizes, especially smaller sizes, use a short-wheelbase design with the front wheel close to the pedals.

Increasing the distance between the front wheel and the pedals could place the handlebar too far away or make the steering unwieldy. On bicycles where this distance is short,

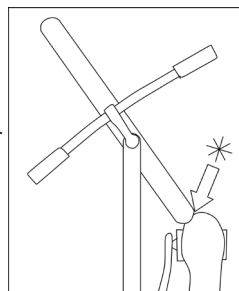

Fig. 3. Toe overlap.

is turned during very slow speeds your foot or toe-clip could overlap or touch the front wheel or fender (Fig. 3).

## **WARNING**

If your foot or toe-clip touches the front wheel or fender, this could decrease your control and cause a fall. Do not pedal when you turn at slow speed.

This overlap is affected by the size of your feet, the length of the crankarms, and the pedals you choose. At usual speeds, the handlebar does not turn sufficiently for overlap to occur. When you ride slowly, do not pedal when the handlebar is turned.

## Hot Spots, Moving Parts, Sharp Areas, and Pinch Points

Some parts of your e-bike can injure you if mishandled. Sharp areas include chainring teeth, pedals, and brake discs. Brakes and their parts get hot. Moving parts can cut skin and even break bones. Clamps and pivoting parts such as brake levers can pinch, as can the chain where it runs over sprocket teeth.

range of operating conditions, so it is not possible to provide a precise schedule for replacement. Any cracks, scratches, or significant color changes indicate that a component's life has been reached and should be replaced. Consult your dealer if you have any areas of concern.

Good maintenance practices and frequent inspections will ensure that you get the most out of your investment.

### **WARNING**

A frame or fork problem can decrease control and cause a fall. If your e-bike gets a shimmy or any other issue, decrease speed immediately and take it to your dealer for service.

### **WARNING**

E-bikes are subjected to wear and high stresses. Different components react to these stresses differently. If the design life of a component is exceeded, it may suddenly fail and cause injury to the rider.

## Frame or Fork Problem

Frame problems are uncommon, but an early warning sign can be the presence of a shake or shimmy while riding at some speeds. If you experience this, or any other problem, decrease speed immediately and do not ride the e-bike. If your e-bike behaves in an unusual manner or makes excessive noise, take the e-bike to your dealer for service.

## Life Span of an Electric Bicycle

E-bikes and the components that comprise them are not indestructible. Depending on the riding forces, conditions, and mileage endured, you should replace your e-bike or its parts at an appropriate frequency.

The safe life of a part is determined by its construction, materials, and wide

# BEFORE EVERY RIDE

## **WARNING**

This is not a comprehensive maintenance program. Montague recommends that you have your e-bike tuned and safety checked by a bicycle technician familiar with e-bikes on a regular basis but no less than annually. If you notice any irregularities in your bike and/or its performance take it to a bicycle dealer before attempting to ride. Overuse of any brake system may cause loss of control resulting in personal injury.

Ensure that your e-bike is in proper working condition each and every time you ride. If a part of the e-bike does not function correctly, consult this manual and bring the e-bike to your local dealer for repair.

## **WARNING**

An e-bike that does not work properly can cause you to lose control and fall. Do not ride an e-bike with a part that is damaged; replace the part before riding.

### **Before Each Ride Mechanical Checklist**

- Frame and Fork
- Wheels
- Tire Inflation
- Brakes
- Handlebar and Stem
- Saddle and Seatpost
- Suspension
- Quick Releases
- Lights & Reflectors
- General

### **E-Bike Drive System and Battery**

It is important to thoroughly inspect the drive-assist system and electronics

before each ride. Perform inspection and review the items on the following checklist.

### **Before Each Ride Drive Assist System Checklist**

- Check battery charge level
- Check the lock for the battery to ensure it is secured in the dock
- Visually check the rechargeable battery for damage
- Visually check the drive train for damage and check the operation of the system
- Visually check whether cables and connectors are securely in place and look for damage
- If you discover any missing or damaged parts, do not use the e-bike. Have an authorized dealer repair your e-bike

### **Carbon Fiber Composite**

Some models have carbon fiber components. Pound for pound, carbon fiber is stronger than steel or aluminum. But it behaves differently when it is overloaded in an accident or impact. An overloaded metal part will bend or deform before it breaks, showing evidence of the load (Fig. 4).

An overloaded carbon fiber part will not bend or deform, so a damaged carbon part (with reduced strength due to the damage) may look normal - even after the same load that bent the metal part. But when the sum of the forces finally exceeds the strength limit of the carbon fiber, the carbon fiber part breaks, it does not deform (Fig. 4).

In an accident or impact that does not break the carbon fiber, the carbon fiber could have internal or hidden damage but appear normal. If that occurs, please carefully read these instructions and examine the carbon fiber. These tests are not conclusive: If you are not sure a part is safe, replace it.

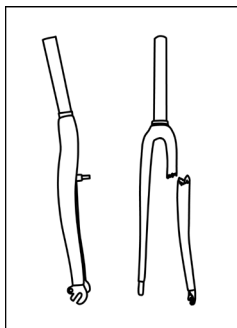

Fig. 4.  
Overloaded forks:

- The metal fork on the left bent when overloaded
- The carbon fiber fork on the right failed at a much higher load, but separated.

## **⚠ WARNING**

A carbon fiber part that has damage can break suddenly, causing serious injury or death.

Carbon fiber can conceal damage from an impact or crash. If you suspect your bicycle has had an impact or crash, immediately stop riding the bicycle. Replace the part before riding, or take to your dealer for service.

## **Carbon Fiber Test**

To examine for surface problems

1. Clean the part fully with a moist cloth.
2. Look carefully for problems. These include scratches, gouges, cracks, discoloration, loose fibers, or other surface imperfections.

To examine for a change of the rigidity (flex test):

Do not ride, but use the part in the usual manner while someone carefully examines the part for movement or unusual noise.

To examine for delamination (tap test):

1. Clean the part fully with a moist cloth.
2. With a coin, tap near the area you suspect damage.
3. Listen carefully for variations in sound. Tap on the part where it is in good condition (or use a part that is almost the same). Compare the sound. Anything unusual, especially a hollow sound, indicates a problem.

## **Protect from Extreme Temperatures**

Protect carbon composite components from extreme temperatures when storing or transporting your bike.

Allow carbon composite components to cool off or warm up before you ride. Do not store a bike with carbon components in places where the temperature will exceed 66.5°C (150°F). For example, do not



leave your bike lying flat in a black pickup truck bed in the desert sun or under the glass of a hatchback auto.

Excessive heat, such as that used in powder coating, or any open flame, may damage the adhesive which joins carbon composite parts. Do not exceed 180°F (82°C) exposure to your frame.

## Examine the Frame and Fork

Before and after each ride, examine your e-bike for signs of fatigue and stress. Such signs may manifest themselves in the form of:

- Dents
- Cracks
- Scratches
- Deformation
- Discoloration
- Unusual Noises

If your bicycle receives a high force load or impact, fully examine all the parts of your bicycle. High force loads include crashes and strong impacts that do not cause you to crash. If you are unsure whether or not to replace a part, speak to your local dealer.

## Examine the Wheels

Check the attachment of both wheels. With the quick release lever in the “close” position, pick the front wheel off the ground and apply force to the wheel in a downward motion (Fig. 9 page 28). The wheel should remain securely in place. Grab your wheel and try to move it from side to side. Check the rims for cracks, discoloration, and trueness. If

there is any movement or irregularity in the wheel do not ride your bike. Take it to your local dealer for service.

When the quick release lever is properly adjusted and in closed position you should not be able to rotate the lever in a circular motion (parallel to wheel). This is different from the “flipping” motion, used to open and close the quick release lever (Fig. 8 page 27). Repeat the same steps to check the rear wheel.

### **WARNING**

A wheel quick release that is not properly adjusted or closed can cause the wheel to loosen or come off, suddenly stop its rotation, or decrease your control, causing you to fall. Make sure the wheels are correctly attached before riding your bicycle.

Note that different systems attach bicycle wheels to the frame: threaded axle nuts, and multiple styles of a lever actuated quick-release system.

Make sure the wheels are straight. Turn each wheel and look at the rim when it goes through the brake pads or the frame. If the rim wobbles up and down or from side to side, repair the wheel.

## Examine Tire Inflation

### **WARNING**

Excess air pressure can cause the tire to explode off the rim, causing hearing loss or, if riding, a loss of control. Use a hand pump with a reliable pressure gauge and do not overinflate.

Inflate the tires to the air pressure recommended on the sidewall of the tire. Improper tire pressure will cause excessive wear, causing premature replacement. Pressurized, unregulated pumps should not be used for this task.

The tire should be properly seated in the rim and the fitting of the tire bead and rim bead should be checked. If the tube is pinched between the tire and the rim, it can explode when inflated. Ensure that the tire is not cracked or unevenly worn. Check for bulges. Check that the valve is straight in the rim. Irregular tires should be replaced immediately.

## Examine the Brakes

### **! WARNING**

A brake system that has damage or is not adjusted properly could decrease your control and cause you to fall. Inspect brakes fully before each ride, and do not ride if brakes are not operating correctly. Make adjustments as needed or take to your local dealer for service.

Your Montague e-bike is equipped with disc brakes. The hand lever causes the brake to apply pressure to a disc attached to the hub. Follow the inspection instructions for disc brakes.

### **! CAUTION**

Disc brakes and discs get very hot during use and could burn skin. Also, the disc edges can be sharp and could cut skin. Do not touch the disc or disc brake when it turns or when hot.

Pull the brake lever to make sure the brake moves freely and stops the bicycle. If the brake lever can be pulled to the handlebar, the brake is too loose. When brakes are not applied, the brake pads should be .25-.75mm away from the disc. If the pads are too near to the disc, the brake is not in line or it is too tight and the brake should be adjusted.

## Examine the Steering

### **! WARNING**

Never ride a bike with an improperly adjusted handlebar or stem as this can cause you to lose control of the bike, leading to serious injury or death. Also, handlebar ends that are not plugged or covered can cut in a crash.

Make sure the stem is in line with the front wheel and correctly attached to the fork and handlebar.

To examine the connection to the fork, try to turn the handlebar from side to side while you hold the front wheel between your knees (Fig. 5). To examine

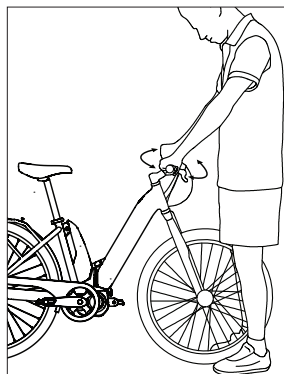

Fig. 5:  
Try to turn the handlebars while holding the front wheel between your knees.

the connection of the handlebar, try to twist it in the stem. The handlebar should not move or be loose. Make sure that no cables are pulled or caught on the bicycle when you turn the handlebar. If the handlebar or stem is loose to turn, bring the bike to a local dealer for inspection.

## Saddle and Seatpost

Make sure the saddle is correctly attached and the minimum insertion line on the seatpost is not showing. Try to turn the saddle and seatpost in the frame, and try to move the front of the saddle up and down. The saddle should not move or be loose. If the saddle is loose try adjusting it using the instructions on pages 32 & 51.

## Suspension

On select models, adjust your suspension for your use, and make sure that no suspension component can “bottom-out”, or be fully compressed while riding. Refer to the enclosed supplementary manual for the suspension fork equipped on your bike.

## Quick Releases

Check that all quick releases (front wheel, frame, seatpost, rear wheel, stem) are fastened. Nothing should rattle or be loose.

## Lights & Reflectors

Make sure lights operate correctly and are turned on. Make sure all reflectors are clean and in their correct position.

Your Montague e-bike comes equipped with front and rear lights powered from the main e-bike battery. For additional information regarding operation, please refer to the supplemental drive system manual.

## General

Check to make sure nothing seems loose or rattles. Check that both pedals are properly threaded into the crank arm.

## **WARNING**

Without correct lights and reflectors, it will not be easy for you to see or for other people to see you. If you cannot see, or other people cannot see you, you could have an accident. Use a front light, a rear light, and reflectors when you ride in low visibility conditions.

# RIDING SAFELY

The first rule in safe e-bike riding is to use common sense. An e-bike is vulnerable; it cannot protect you in a crash, impact, or loss of control the way a car can. An e-bike can tip over sideways or pitch you over the front wheel. It does not have bumpers or airbags as a car does. This section is a guide of safe riding practices for on- and off-road operation. Make sure you are using your e-bike for the proper use condition (page 6) as it relates to off-road riding.

Different localities and countries have different laws governing e-bike riding on public roads, and you should check with local officials to make sure you are complying with these laws.

- For your safety, always wear a helmet that meets CPSE or CE safety standards. In the event of an accident a helmet can protect you from serious injury and even death. A bicycle dealer will be happy to assist you in the selection of a helmet and other useful accessories.
- Obey all local traffic laws. Obey red and green lights, one-way streets, stop signs, etc.
- Ride with the traffic, not against it. Ride single file in a straight line.
- Have a satisfactory signaling device (bell, horn, etc.), to warn of approach. Ride defensively (expect the unexpected).

- Give pedestrians the right of way. Do not ride too close to pedestrians and alert them if you intend to pass from behind.
- Slow down at all street intersections and look to the left and right before crossing.

## **WARNING**

Proper use of your front brake is vital to ensure safe, efficient stopping. To avoid misuse and potential injury, do not apply sudden or excessive force to your front brake. Doing so may cause your rear wheel to lift off the ground and/or your front wheel to slip from under you. Apply both brakes at the same time and shift your weight backward on the e-bike while braking.

- Always use proper hand signals for turning and stopping. Give signals 100 ft. before stopping or turning and always return both hands to the handlebars before stopping or turning.
- Watch for cars pulling out into traffic and for the sudden opening of car doors.
- Avoid potholes, drainage grates or other road surface hazards. Cross railroad tracks at a right angle. Be careful when riding on soft road edges, gravel, sand and uneven surfaces. Ride slowly and avoid quick turns when riding on these surfaces.

- Never hitch on to other vehicles, do not “stunt” ride or race in traffic. Do not weave in and out of the traffic or swerve from side to side.
- A crash can put extraordinary stress on bicycle components, causing them to fatigue prematurely. Components suffering from stress fatigue can fail suddenly, causing loss of control, or serious injury. For more information and a guide for safe on-road and off-road riding, see [www.montaguebikes.com/support](http://www.montaguebikes.com/support).

## Caution: Wet Weather Riding

Brakes do not work as well under wet conditions as they do when dry. In wet weather, special precautions must be taken to ensure safety in stopping. Proper adjustment and cable lubrication will help, but the major precaution rests with you, the rider. Increased brake pressure is needed in wet or rainy weather and care must be taken to maintain safety in these conditions.

### **WARNING**

Wet or inclement weather can make an e-bike difficult to control. Decrease your speed and use extra caution, or use other types of transportation.

Ride slower than normal and apply your brakes sooner than regular conditions would require.

When wet surfaces freeze, traction is further decreased. Brake power could decrease. Adjust your speed.

## Be Seen (Especially at Night)

Your e-bike comes equipped with front and rear lights that are powered from the main e-bike battery. These lights are not designed to improve your vision when riding at night, but can help with being seen by others. Please refer to the supplementary drive-assist manual for full instructions on operating the lights.

Your e-bike has a full set of reflectors. Make sure the reflectors are clean and in the correct position. As useful as these reflectors are, they do not help your vision. They do not make you easy to see unless light is pointed at them. You should see and be seen. If you ride at dusk, at night, or in low-visibility conditions, speak to your dealer to find equipment or materials to help your vision and make you easier to see.

### **WARNING**

When you ride in low-visibility conditions such as fog, dusk, or night, you might be difficult to see, which could lead to a collision. Your bicycle is equipped with reflectors. In addition to keeping your reflectors clean, and properly affixed to your bicycle, use a front light and rear light when you ride in conditions with low light or low visibility. Wear bright, reflective clothing when riding in poor lighting conditions. Consult your local bike shop to find accessories and clothing appropriate for your riding needs.

## Think Safety

Think about safety when you ride. You can prevent many bicycle accidents if you think about safety. For example:

- Check your e-bike before every ride, making sure that your brakes are operating effectively and everything is in perfect working condition.
- Do not ride ‘no hands.’
- Do not ‘ride double.’
- Avoid riding in large groups, as this can force you to ride too close to other riders, making it difficult to see other vehicles and road hazards. When another rider is close, a sudden change in direction or speed can cause you to lose control.
- Do not ride above your skill level.
- Do not ride too fast - with increased speed comes increased risk. Higher speed causes small bumps to create large impact forces on your forks and frame, and results in higher forces and risk of injury if a crash occurs.
- Do not ride with loose objects attached to the handlebar or other parts of the bicycle, for example with a pet or its leash.
- Never carry other riders or packages, as they may obstruct vision or proper control of the bicycle.
- Do not ride while intoxicated or while taking medications which can make

you drowsy.

- Ride carefully when off-road, staying on trails, and not riding over rocks, branches, or depressions.
- When approaching a descent, decrease speed, move your weight to the rear, and use the rear brake more than the front.
- Do not ride abusively, ride within the Use Conditions specified for your bicycle type.

## **WARNING**

You add to your risk of injury when you use your e-bike incorrectly, for example when you:

- Jump your e-bike
- Ride over sticks, debris, or other obstacles
- Do stunts
- Ride in severe, off-road terrain
- Ride fast, in competition, or “downhill”
- Ride in an unusual manner

Such examples add to the stress on each part of your e-bike. High stress can cause the frame or a part to break and increase your risk of injury. To decrease your risk of injury, use your e-bike correctly.

# RIDING INSTRUCTIONS

## Using Your Brakes

Always ride with a safe distance between you and other vehicles or objects. Use your brakes. Adjust speed, braking distances, and braking force based on the conditions you ride in.

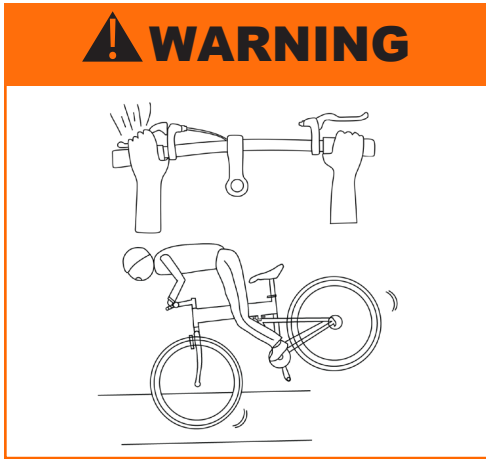

Fig. 6. Do not over-use the front-wheel brake; the rear wheel can lift and cause you to lose control.

Apply pressure to both brakes at the same time. Overuse or incorrect use of a front brake could cause the rear wheel to lift from the ground which can cause an accident (Fig. 6).

Many models of modern brakes are very powerful; they are made to stop a bicycle in wet or muddy conditions. If you think your brakes are too powerful, or not powerful enough, transport your e-bike to your dealer for adjustment of the brake system.

Note: In most countries around the world, including the U.S.A., France, and Germany, the left brake lever operates

the front brake, and the right brake lever operates the rear brake (note: bicycles manufactured for the United Kingdom and some other countries switch these and the left brake lever operates the rear brake and the right brake lever operates the front brake).

## Changing Gears Correctly

The multi-gear system provides a means of maintaining a constant pedaling rate, regardless of road level conditions.

The gears are activated by cables connecting the shift levers located on the handlebar to the derailleurs.

If your e-bike is equipped with twist shifters, rotating the twist shifters towards you moves the chain from one chainring (or sprocket) to the next larger chainring (or sprocket). Rotating the twist shifters away from you moves the chain from one chainring (or sprocket) to the next smaller chainring (or sprocket).

If your bicycle is equipped with shift levers, pushing the thumb shift lever away from you moves the chain from one chainring (or sprocket) to the next larger chainring. Pulling the index finger shift lever towards you moves the chain to the next smaller chainring (or sprocket).

The left shifter controls the front derailleur and the right shifter lever controls the rear derailleur. To shift, continue pedaling at a steady pace while operating the shifters and engage the gear you find most comfortable.

For easiest pedaling (while going uphill), position the chain over the smallest chainring in front and the largest sprocket in back. For hardest pedaling (while going downhill or quickly), position the chain over the largest chainring in front and the smallest sprocket in back.

For models with an external derailleur, pedals and wheels must be turning forward while shifting gears. Never pedal backward while shifting gears and never force the twist shifters or shift levers.

If your bicycle is shifting incorrectly, please review Derailleur Adjustment on pages 49-51 or take the bike to your local dealer.

## Descending

The keys to safely and effectively descending a hill are speed control, weight distribution, and steering control.

### Speed control

Your speed is controlled through experience and good braking, (covered earlier). Remember that e-bikes require more braking force than conventional bicycles due to increased speeds.

### Weight distribution

Keep your weight correctly in balance between the wheels on a steep downhill by moving your weight rearward on the e-bike and as low as possible, just

like when braking. Keep your feet on the pedals and keep the crank arms horizontal and parallel to the ground (unless you are cornering as you descend; see the next section). Keep your knees and elbows bent to allow your body to absorb some of the bumps and impacts during the descent. For extra stability, squeeze the seat between your thighs (some folks even like to squeeze the top tube with their legs). Avoid a “death grip” on your brakes, instead use them as outlined in the Using Your Brakes section.

### Steering control

When cornering, do the majority of your braking before you make your turn, and stop pedaling before entering the corner.

Hard braking during the turn can cause your wheels to skid, which could cause you to lose control. Make sure your speed is reasonable, then ease off the brakes when you’re about halfway through the turn.

To avoid catching the inside pedal on the ground, make sure that your outside pedal is down and your weight is on the outside pedal. Lean your e-bike in the direction of the turn, but slightly angle your upper body in the opposite direction, keeping your body and head more upright.



## Obstacles and Impacts

Always look well down the road to help you anticipate upcoming obstacles. This distance will vary according to your speed, but remember that the closer you get to an obstacle, the less time you have to react to it. Due to the greater acceleration and speed of an e-bike, you may approach obstacles faster than expected.

Use caution when you encounter obstacles in the road, whether it's a sewer grate, speed bump, gravel, or any other hazard. If you are going fast, even a small obstacle can create a significant impact to your bicycle. If you are unsure of your ability to safely ride over an object, it is best to either ride around it or dismount and walk around it.

Your body and bicycle will have a natural tendency to go where you are looking. If you focus on an obstacle, you may go through it when you really wanted to avoid it. Focus on the part of the road where you want to go, not on the obstacles.

# ASSEMBLING YOUR MONTAGUE BICYCLE

Your new e-bike was assembled and tuned in the factory and then partially disassembled for shipping. You may have purchased the e-bike already fully assembled and ready to ride OR in the shipping carton in the partially disassembled form.

If you have questions or concerns about any of these steps, please see a bicycle dealer or contact Montague's Customer Support Team at +1 617-491-7200.

Carefully follow the Final Assembly Instructions attached to your bike. Once you have completed the assembly, read the remainder of this Owner's Manual.

## Packing List

Inside your box you will find:

- 1 Mostly Assembled Bicycle
- 1 Front Wheel
- 1 Saddle with seat post
- 1 Small Parts Box which includes:
  - 1 15 mm Pedal Wrench
  - 1 Hex wrench
  - 1 10 mm open end wrench
  - 1 Front wheel quick release
  - 1 Steering damper spring
- 1 Battery (some models)
- 2 Keys for battery (some models)

## WARNING

Never attempt to ride a bicycle that is not properly assembled.

Carefully remove the e-bike and all accessories from the box to avoid scratching the frame. Check the carton for loose parts before discarding.

## Assembly

Note: Depending on the model year and design, your e-bike may be assembled differently. Refer to the Final Assembly Instructions attached to your bike for the most up to date information.

For additional manuals, please visit [montaguebikes.com/online-owners-manual/](http://montaguebikes.com/online-owners-manual/).

## Installing Front Wheel Quick Release

The front wheel quick release skewer is shipped separately and can be found in the small parts box. To install it in the front wheel:

1. Remove the quick release adjustment nut by rotating it counter-clockwise to loosen. Remove the first spring next to the adjustment nut, and set both pieces aside (Fig. 7).
2. Slide the quick release skewer into the hollow axle of the front wheel hub, with the quick release lever located on the side opposite the disc brake rotor. The lever being on the correct side is important to ensure the bike can fold completely.
3. The end of the skewer should stick out from the opposite side of the hub. Slide the spring that was removed in step 1 back onto the end of the skewer, and thread the end nut back onto the skewer, turning it clockwise. You can see the layout and order of parts in Fig. 7 on the opposite page.

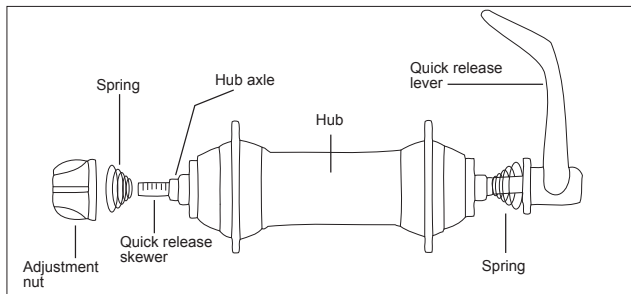

Fig. 7: Traditional quick release; diagram of parts.

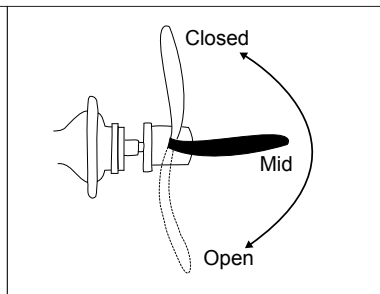

Fig. 8: Positions of a quick release.

## Installing the Front Wheel

The front wheel of your new bicycle attaches to the fork with a traditional wheel quick release.

### **! WARNING**

Improper installation or improper use of the quick release system can allow the wheel to **WOBBLE** or **DETACH** from the bicycle causing you to crash. Read and follow these instructions to properly install and use this product to reduce your chance of **SERIOUS INJURY** or **DEATH**.

### To install a wheel with a traditional quick-release

1. Move the quick release lever to the **OPEN** position (Fig. 8) and set the wheel so it fully engages the frame dropouts.
2. With the lever in the **MID** position (Fig. 8), tighten the adjusting nut (Fig. 7) until it is slightly tight.

### **! WARNING**

**DO NOT** change or swap wheels between different bicycles. Your wheels may not engage the other bicycle's fork correctly causing an accident.

3. Move the quick release into the closed position (Fig. 8) with the palm of your hand.
4. A properly closed quick release lever should leave a mark on the palm of your hand from closing. Check that the word "Close" is visible and that the lever is pushed fully to the closed position. Make sure that the lever is positioned adjacent to the fork blade so it will not catch on any passing objects.
5. If you can lock the lever with little or no resistance, the clamp-force is not sufficient. Go back to step 2 and tighten the adjustment nut 1/4 turn and return to step 3.
6. Examine for correct quick release adjustment. With the quick release



Fig. 9: Strike the wheel in a downward motion.

closed, lift the bicycle and hit the top of the tire with a solid blow (Fig. 9). The wheel should not come off, be loose, or move from side to side.

If your front or rear disc brake needs to be adjusted or does not apply adequate stopping power to the wheel, it may need to be adjusted. Be sure to squeeze the brake levers to ensure that the brakes are secured in place and functioning properly before riding. For adjustment instruction, please see Brakes on pages 54-55.

## Rotating the Stem

Your Montague e-bike comes equipped with a handlebar stem that folds down to create the smallest folded bike size possible. The installation and use of this stem is unique to Montague. For more details, please see Proper Maintenance and Adjustment on page 50.

For packing purposes, the stem is rotated 180 degrees from the proper riding position.

To rotate the stem to the riding position:

1. Open the stem quick release (Fig. 11), and begin to fold the stem down (Fig. 12). This will provide access to the expander bolt (Fig. 13).

## Disc Brake (Fig. 10):

To attach the front wheel on a disc brake equipped bike, align the wheel rotor with the slot in the disc brake caliper attached to the left hand fork stanchion.

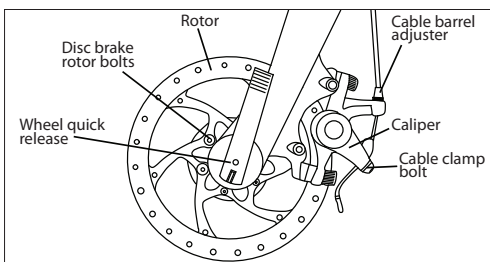

Fig. 10: Disc Brake.

Once the rotor is aligned with the caliper slot, review Installing the Front Wheel on page 27 in order to properly secure the front wheel quick release.

**Note:** When installing the front wheel on a disc brake equipped model, the disc brake rotor is lined up between the brake pads in the caliper slot. If the pads are knocked out of place, the rotor may not go into the caliper slot. Reset the pads before attempting to install the wheel.

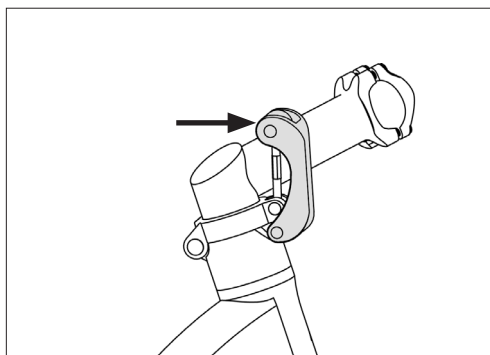

Fig. 11: Open the handlebar stem quick release.

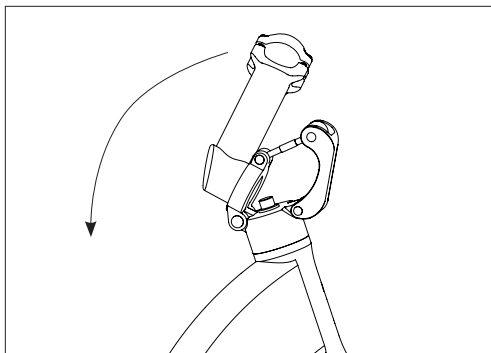

Fig. 12: Fold down the stem.

2. Decrease the tightness of the expander bolt by two or three turns by rotating it counter-clockwise (Fig 13).

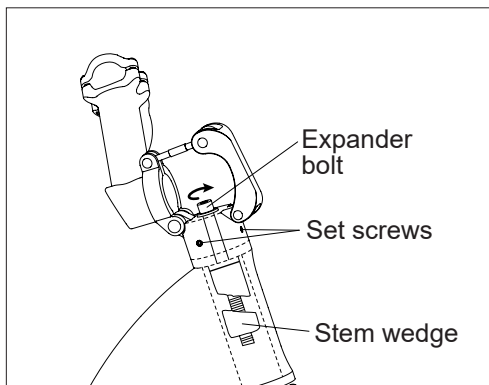

Fig. 13: Stem mounting parts.

3. Fold the handlebars back to the upright position, and close the stem quick release. This will allow you to properly align the stem with the front wheel.
4. Decrease the tightness of all (4) set screws by two or three turns (Fig 13).

5. Rotate the stem 180 degrees so that it extends forward from the frame, and is aligned parallel with the front wheel.
6. With the stem aligned parallel with the front wheel, apply a clamping force between the top of the stem assembly and the fork crown. This will press the stem down onto the headset bearings (Fig. 14).

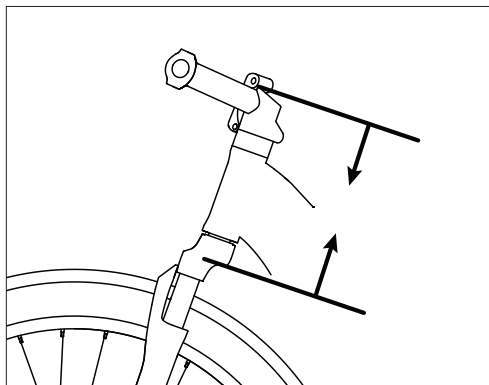

Fig. 14: Apply clamping force to tension headset

7. While applying the clamping force, tighten all (4) set screws around the bottom of the stem. This will temporarily hold the stem in place until the expander bolt is tightened.
8. Open the stem quick release and begin to fold the stem down to provide access to the expander bolt.
9. Tighten the expander bolt to 120 lb•in (13.6 N•m).
10. Unfold the stem so that it is back in the upright position, and close the stem quick release.

## Installing the Handlebars

For some models, the handlebars are shipped off the bike. If so:

1. Using the provided hex wrench, remove the two screws (or four, depending on model) holding the stem clamp in place (Fig. 15).

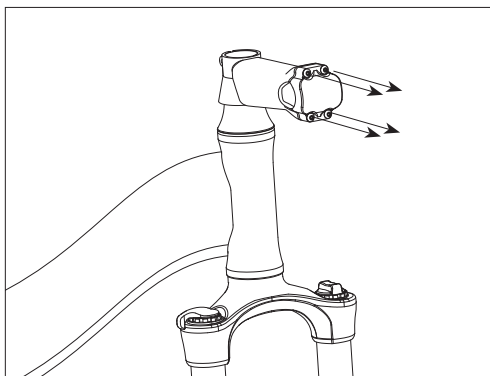

Fig. 15: Remove the stem clamp.

2. Place and center handlebars within the stem (some have centerline marks), and replace screws (Fig. 16).

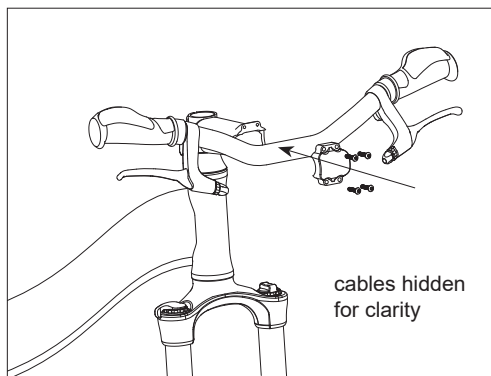

Fig. 16: Replace and center handlebars.

3. Tighten with the provided hex wrench (Fig. 17) to proper torque (page 49). Make sure that the gap between the stem is roughly the same on the top and bottom (Fig. 18, a), and the handlebars are at a comfortable riding angle (Fig. 18, b).

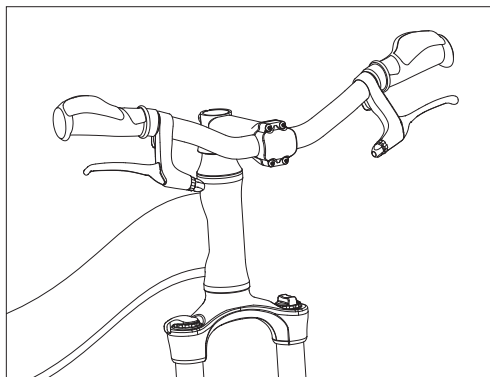

Fig. 17: Tighten screws.

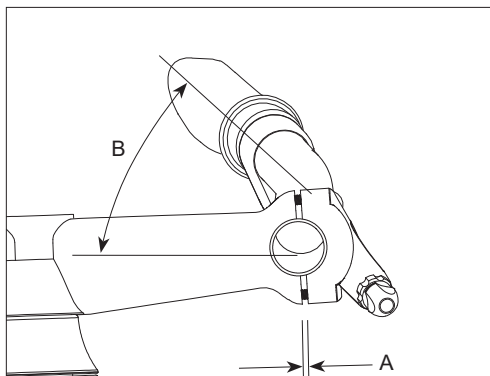

Fig. 18: Set at comfortable angle.

To complete the assembly of your Montague bicycle, continue with the instructions provided in the next sections, **Installing the Front Wheel**, **Unfolding the Pedals**.

## Installing the Front Fender

The front fender mounts to three points on the fork. The mounting bolts will already be in place on the fork arch and fork lowers. To install the fender:

1. Remove the nut from the mounting bolt on the fork arch by turning it counter clockwise (Fig 19). An L shaped bracket is being held in place by the nut. Slide the L bracket off the bolt and place the nut and bracket aside.

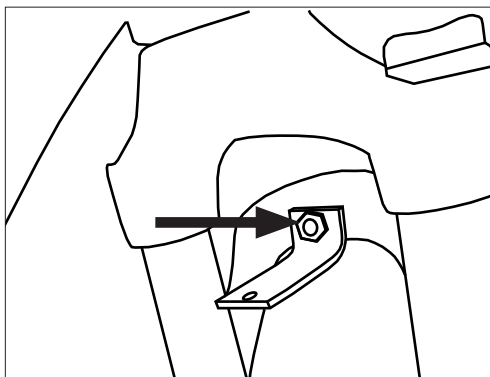

Fig. 19: Fender mounting bolt nut on fork arch

2. Move the fender into place, with one mounting arm on each side of the wheel (Fig. 20). The slotted hole on the top of the fender should slide over the mounting bolt on the fork arch.
3. Replace the L shaped bracket and nut by sliding the bracket over the mounting bolt, and threading the nut onto the bolt. The slotted hole of the fender should be sandwiched between the L shaped bracket and the fork arch (Fig 21).

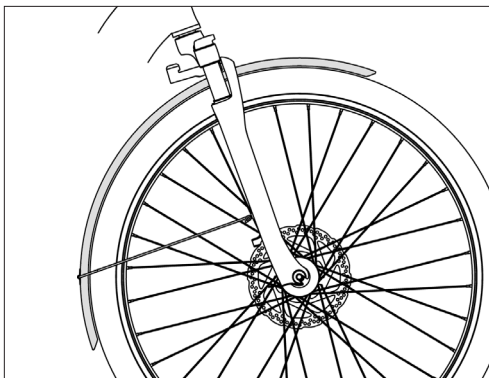

Fig. 20: Front fender in place

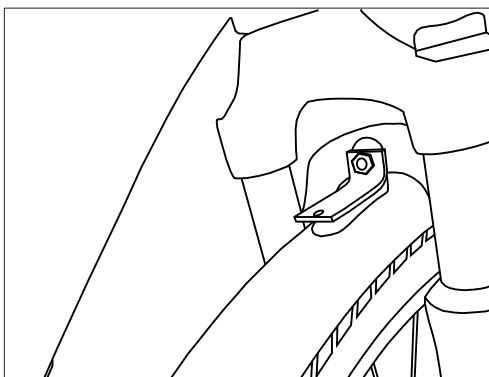

Fig. 21: Fender in place with nut and L bracket re-attached.

4. Remove the two mounting bolts on the fork lowers by turning them counter-clockwise to loosen (Fig 22, page 32).
5. Pass the bolts through the eyelets on the ends of the mounting arms, and re-attach them to the fork. Turn them counterclockwise to tighten (Fig 22, page 32).



Fig. 22: Mounting bolt on fork lower

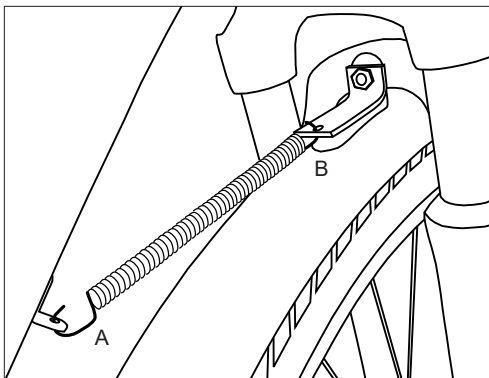

Fig. 23: Steering damper spring

## Attaching the Steering Damper Spring

A steering damper spring is included to keep the fork and handlebars from turning on their own and falling to one side when the bike is parked. It does not affect handling of the bike while riding. The spring can be found in the small parts box. To attach it:

1. Loop the hook on one end of the spring through the eyelet on the underside of the frame's top tube. It is located directly behind the fork arch (Fig. 23, a).
2. Using a pair of pliers to grip the hook on the opposite end of the spring, stretch the spring toward the fork arch. This requires considerable force, so be sure the pliers have a secure grip on the spring.
3. Insert the hook end into the opening in the L shaped bracket attached to the fork arch (Fig. 23, b).

## Installing the Seatpost

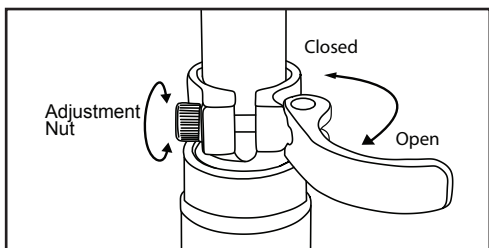

Fig. 24: Opening and adjusting a quick release.

## **⚠ WARNING**

A seatpost that is too high can cause damage to your e-bike or decrease your control and cause you to fall. Make sure the minimum-insertion line is in the frame (Fig. 25).

1. Open the seatpost quick release lever (Figs. 24 & 25).
2. Insert the seatpost into the seat tube to a sufficient depth so that the minimum insertion line is no longer showing (Fig. 25).



- When you are satisfied with the height of the seatpost, close the seatpost quick release lever. The tightness of the lever is adjusted by rotating the adjustment nut opposite the quick release lever. Turn the nut by hand to adjust the tension while holding the lever stable (Fig. 24).

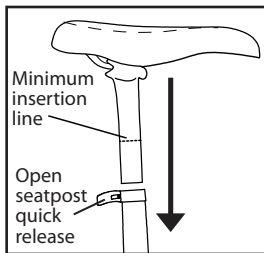

Fig. 25: Insert seatpost beyond minimum line.

- The lever is securely tightened when it leaves an imprint on the palm of your hand from pushing it closed.
- Once the lever is securely closed, you should not be able to move it unless you open it again. If you can move the seat up and down or side to side with the quick release lever in the closed position, repeat the seatpost installation process from step 3. Repeat until the seat cannot be moved when the quick release lever is closed.
- If you have adjusted the nut too tightly and cannot push the lever to the “close” position, open the quick release lever again and turn the adjusting nut 1/4 turn counterclockwise. Continue with Step 3.
- Adjust the height for comfort of the rider. The saddle is properly adjusted

when you can sit on the saddle, and with your knee only slightly bent (approximately 15°), reach the pedal at its lowest point with the ball of your foot.

## Installing the Pedals

You will find both pedals in your small parts box. The pedals are marked and stamped “R” for Right, and “L” for Left. The crank arms are also clearly marked “R” and “L” to differentiate between right and left.

Each pedal can only be installed on the corresponding side of the bike, as they thread on in opposite directions. The right pedal threads on, clockwise, as normal. The left pedal threads on by turning it counter-clockwise.

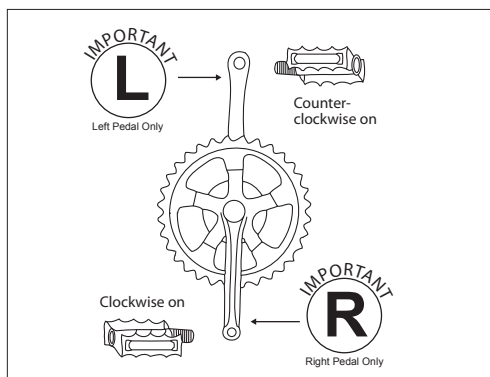

Fig. 26: Install the pedals.

## **⚠ CAUTION**

Do not try to insert the wrong pedal into the crank, as it will strip the crank threads. Always check that the pedals are securely tightened before riding.

1. Align the right pedal axle into the threaded hole in the right crank arm and secure it in the crank by hand. The right hand side of the bicycle is the side of the bicycle with the chain.
2. The **right** pedal is installed by turning the pedal axle clockwise (Fig. 26).
3. Align the left pedal axle into the threaded hole in the left crank arm and secure it in the crank by hand. The left hand side of the bicycle is the side of the bicycle opposite the chain.
4. The **left** pedal is installed by turning the pedal axle counter-clockwise (Fig. 26).
5. When both are hand-tight, use the 15mm pedal wrench (in small parts box) to tighten the pedals to 350-380 lb•in (40.2-42.9 N•m). Each pedal should be tight against the crank arm.

## Inflating Tires and Checking Pressure

Your Montague e-bike is shipped with the rear tire deflated for packing purposes.

1. Remove the valve stem cap, and using a standard bicycle tire pump, inflate the rear tire. Refer to the instructions for your pump to ensure proper use. The recommended pressure for your bike is specified on the sidewall of the tire.
2. Since bicycle tires can lose pressure over time, the front tire may also require inflation. Check the tire pressure and add air if necessary to reach the recommended pressure for your tires.

# FOLDING YOUR MONTAGUE BICYCLE

Your Montague e-bike is designed to fold quickly without the use of tools.

## To Fold Your Bike:

1. Lower the kickstand. Lift the rear end of the bike to allow it to fully straighten. Your bike should now be held up by the kickstand and balancing on its own (Fig. 28).

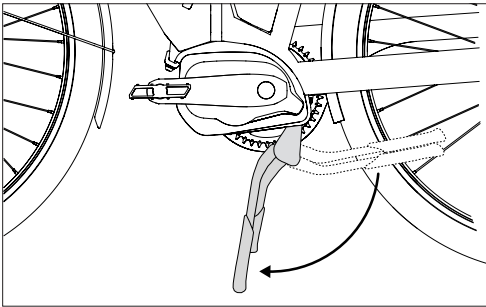

Fig. 28: Lowering the kickstand.

2. In order to fold the frame completely, the crank arms must be positioned properly. Grasp the pedal and turn the crank arms counter-clockwise until the non-drive side crank arm is at its lowest point. It should be perpendicular to the ground with the pedal at the bottom (Fig. 29).

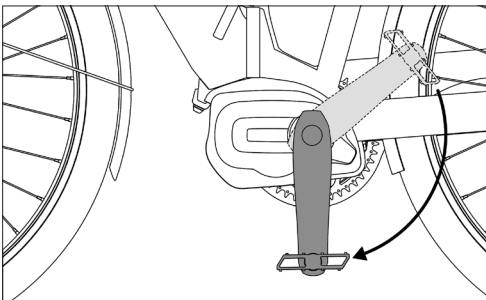

Fig. 29: Reposition non-drive side crank arm

3. Open the frame quick release by lifting up on the lever (fig 30).

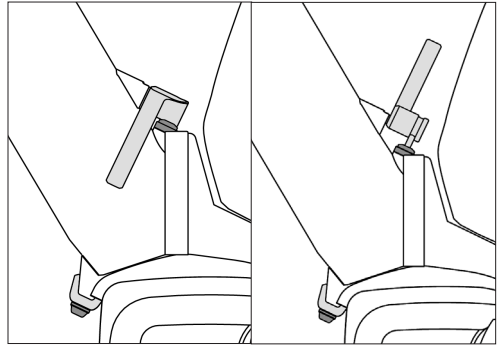

Fig. 30: Open the frame quick release.

4. Press straight down on the center of the frame quick release. The skewer should depress and will release the quick release clamp on the underside of the frame (Fig 31).

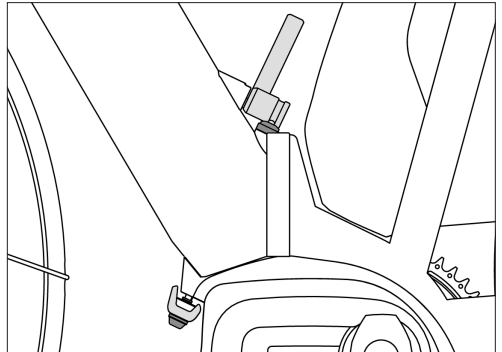

Fig. 31: Press down the frame quick release to allow the frame to fold.

5. While holding the quick release down, fold the bike in half (Fig. 32, page 36).

# FOLDING YOUR MONTAGUE BICYCLE

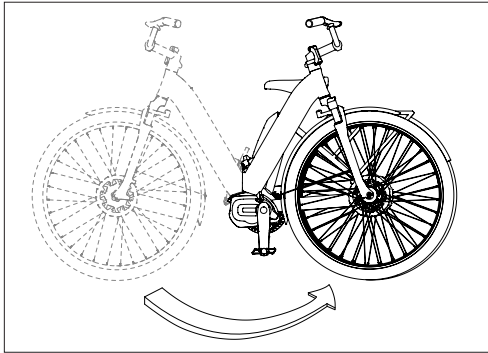

Fig. 32: Fold the bike frame in half.

6. Where the two halves of the bike come together, the front wheel quick release end nut should nestle inside an opening on the rear axle. Ensure the end nut is fully seated inside the opening. (Fig. 33).

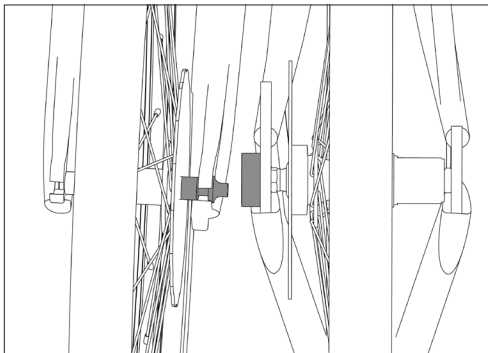

Fig. 33: Front wheel quick release end nut entering rear axle opening.

7. The two halves of the frame can be locked together with a hook located on the front fork, which grasps a post on the rear rack. Press the hook into the post on the rear rack until it clicks into place. (Fig. 34).

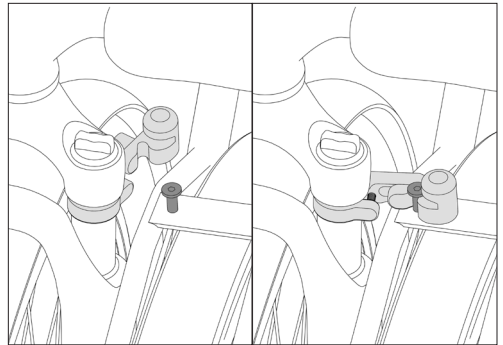

Fig. 34: Lock the folded bike together with hook.

8. Open the seat post quick release and slide the seatpost down until the saddle is completely lowered.
9. Open the quick release lever on the handlebar stem (Fig. 35).

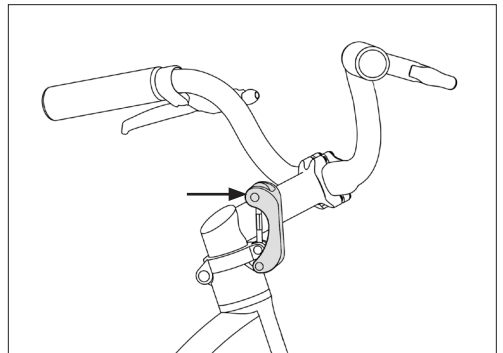

Fig. 35: Open the handlebar stem quick release.

10. Pivot the handlebars to the down position. (Fig 36, page 37). The saddle should be nestled in the middle of the handlebars (Fig. 37, page 37)

# FOLDING YOUR MONTAGUE BICYCLE

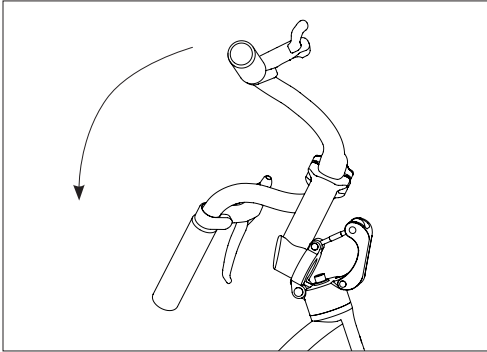

Fig. 36: Fold down the handlebars.

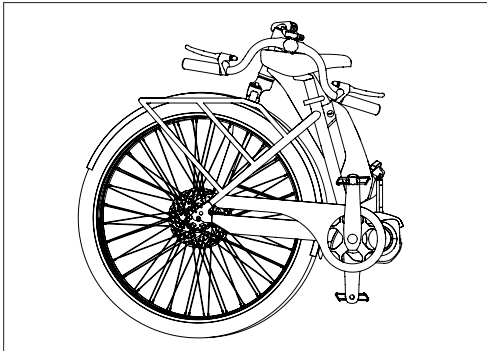

Fig. 37: Folded bike.

## Folding the Pedals

Your Montague e-bike is equipped with folding pedals to provide a more compact size when folding the bike. To fold the pedals:

1. Grasp the outside edge of the pedal, insert your fingers into the center of the pedal body, and squeeze (Fig. 38).

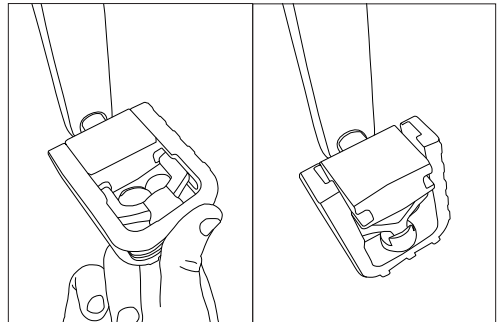

Fig. 38: Folding the pedals

2. The inner spring loaded portion of the pedal body should compress, unlocking the folding hinge.
3. Fold the pedal 90 degrees so it lays parallel with the crank arm (Fig. 38).

# ROLLING YOUR FOLDED BICYCLE

## Rolling the Bike

Your Montague bicycle is designed to be rolled while folded to make transportation easier. In order to roll the bike, the frame must be folded and locked together, with the handlebars in the upright position. Keeping the handlebars in the upright position provides a place to hold the bike while rolling.

1. Follow steps 1 through 8 in “Folding Your Montague Bicycle” (pages 34 - 36). Do not fold down the handlebars or open the handlebar stem quick release.
2. Grasp the handlebars with the drive unit of the bike facing away from you.
3. Press down both brake levers with your thumbs, and tilt the bike toward you. Activating the brakes will lock the wheels and allow you to pivot the bike to a balanced position (Fig. 39).
4. With the motor side of the bike raised, release the brakes, and the bike should now easily balance. You can now roll the bike front of you while walking (Fig. 39).
5. In order to set the bike down, press both brake levers to activate the brakes, and pivot the bike away from you until it rests on the kickstand. Be careful not to drop the weight of the bike onto the kickstand as it could cause damage.

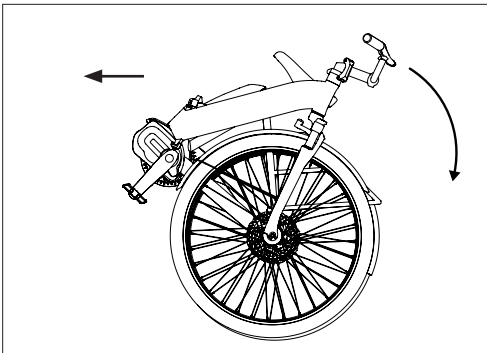

Fig. 39: Rolling the bike while folded.

# UNFOLDING YOUR MONTAGUE BICYCLE

Since your Montague e-bike relies on quick releases for folding and adjustment, it is crucial that you fully understand how to operate the quick release levers.

## **WARNING**

Failure to properly lock the quick release levers for the wheels, seatpost, frame, or brakes can result in loss of control and may result in serious injury or death.

Great care should be taken when locking the quick release levers on the e-bike. After reading this manual if you do not fully understand how to operate the quick release levers, ask a bicycle dealer for assistance, or call Montague's Customer Support Team at +1 617-491-7200. Do not ride your e-bike without all quick releases securely locked.

There are 5 different types of quick releases found on your Montague e-bike. They are as follows:

- The front wheel quick release lever. See *Installing the Front Wheel*, page 27.
- The frame quick release. See *Adjusting the Frame Quick Release*, page 40.
- The seatpost quick release. See page 32 - 33.
- The rear wheel quick release. See pages 27 (same as front wheel).
- The handlebar stem quick release lever. See Fig. 42.

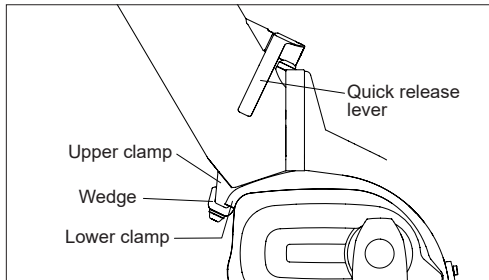

Fig. 40: Parts of the frame quick release.

## To Unfold your Bike:

1. Pivot the stem and handlebars to the upright position (Fig. 41).

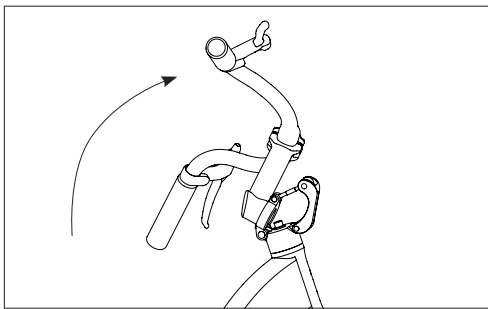

Fig. 41: Folding stem pivot

2. Flip the stem quick release lever to the closed position, and push it tight against the stem. You should feel the lever snap into place, and hear an audible click. (Fig. 42).

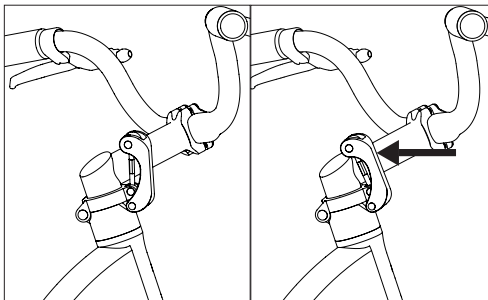

Fig. 42: Left: open position. Right: closed position

3. Once the lever is securely closed, you should no longer be able to pivot the stem along the hinge, and you should not be able to move the stem relative to the front wheel.
4. Ensure the frame quick release is in the open position (Fig. 30 page 35).
5. Unlock the two halves of the frame by detaching the fork latch from the post on the rear rack (Fig. 34, page 36).
6. Unfold the frame, pivoting the front half of the frame until it is aligned straight with the rear half (Fig. 43).

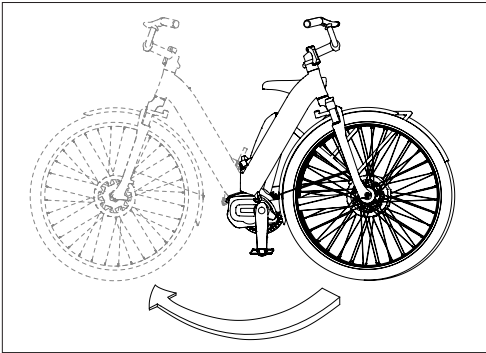

Fig. 43: Unfold the frame

7. Make sure the Wedge is completely engaged. It should hold the Upper and Lower Clamps together, and the frame should no longer fold (Fig. 40).
8. Secure the frame quick release lever by closing the quick release. It should point straight down and lay flat against the frame when closed (Fig. 44)

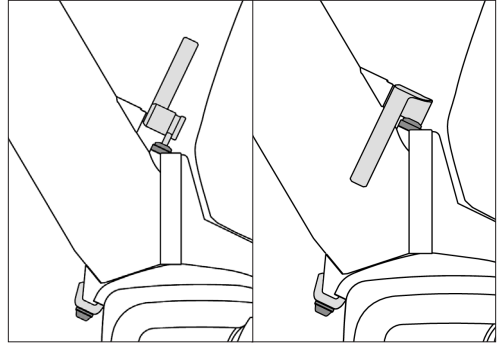

Fig. 44: Close the frame quick release

Note: When closing, if the quick release lever does not leave an imprint on the palm of your hand, refer to Adjusting the Frame Quick Release below (Fig. 45).

9. Raise the seatpost to the desired position (Fig. 24 and 25, pages 32 - 33).

## Adjusting the Frame Quick Release

If the frame quick release becomes loose or does not leave an imprint on your palm when closing the lever, the quick release may need to be adjusted.

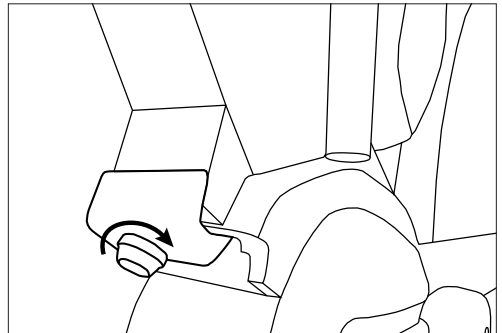

Fig. 45: Tighten frame quick release adjusting nut



1. Make sure your e-bike is in the unfolded position with the frame quick release Wedge properly seated over the Lower Clamp (Fig. 40).
2. Open the quick release lever so the lever is pointing upward. Tighten the adjusting nut by turning it clockwise by 1/4 turn (Fig. 45).
3. Close the lever. If there is too much resistance for you to be able to close the lever, open, and turn the adjusting nut counter-clockwise 1/4 turn and try to close again (Fig. 45).
4. The quick release is securely closed when it leaves an imprint on the palm of your hand from moving the lever into the closed position. Make sure the word “close” is visible and that the lever is pushed fully to the closed position.

## **WARNING**

Great care should be taken when locking the quick release levers on your e-bike. If you do not fully understand how to operate the quick release levers, ask a bicycle dealer for assistance, or call Montague's Customer Support Team at +1 617-491-7200.

**DO NOT RIDE YOUR E-BIKE WITHOUT ALL QUICK RELEASES SECURELY LOCKED.**

## Unfolding the Pedals

If the pedals were folded down for a more compact folded bike size, they must be unfolded before riding

1. Pivot the pedal body 90 degrees, so it is perpendicular to the crank arm. (Fig. 46)
2. The pedal should snap into place and you should hear an audible click. The inner spring loaded portion of the pedal body should lock into the spindle.

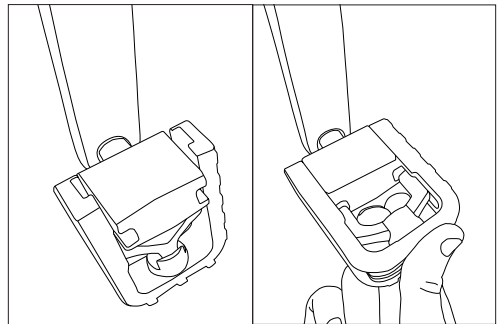

Fig. 46: Pivot folding pedals to riding position

# DRIVE-ASSIST SYSTEM

## Rechargeable Battery

Your Montague e-bike is equipped with a rechargeable lithium ion battery. Please follow the below guidelines for battery longevity and safe operation.

### **WARNING**

Failure to follow the instructions in this section may result in damage to electrical components on your e-bike and will void your warranty, but most importantly, may result in serious personal injury or death. If your battery or charger exhibits any signs of damage, do not use it and immediately bring it to an authorized retailer for inspection.

### **WARNING**

Failure to observe these warnings can result in electrical fires, explosion, or severe burns or electrocution.

Even if all safety precautions are observed, the rechargeable battery can still become dangerous, such as if it catches fire.

In an emergency, make sure that your actions do not put you or other people in danger at any time. Read these instructions so that you can be focused and prepared when reacting to an emergency. Refer to and follow the enclosed system manuals.

- Only operate the battery between the temperature range of 14°F (-10°C) and + 122° F (+50°C).
- Only use the original battery included with your Montague e-bike. Do not use the included battery with any other bicycle, or any other battery with your Montague e-bike, even if it fits.
- Always turn the e-bike's drive-assist system off before connecting or disconnecting the battery.<sup>1</sup>
- Do not modify, open or disassemble the battery or charger. Modification or disassembly may result in a short circuit, fire or malfunction and will void your warranty.
- The battery is heavy. Be careful when handling it and do not drop it.
- Do not allow any nails, screws or other small, sharp and/or metallic objects to come in contact with the battery or the battery's charging socket.
- Do not allow the battery to overheat. Protect the battery from excessive sun exposure.
- Do not expose the battery to open fire or radiator heat.
- Do not submerge the battery in water.
- Keep the battery away from metal objects such as paper clips, coins, nails, screws or keys that can cause a short-circuit.

- Do not use a battery that shows any signs of damage, or is leaking any fluids. Battery liquid can cause skin irritation, burns and respiratory tract issues. In the event of damage that results in skin or eye contact with any liquid from the battery, immediately flush with water and seek medical assistance.

### **WARNING**

Do not use a battery that shows any signs of damage, or is leaking any fluids. Contact with battery liquid can cause serious personal injury.

- Turn off the battery and remove it before performing work of any kind, such as installation, maintenance, cleaning and/or repair. Touching the contacts when the e-bike is ON can result in electric shock and/or injury.

Disconnect the battery from the charger unit when fully charged. Do not leave a fully charged battery connected to the charger. Unplug the charger from the wall outlet when not in use.

Store the battery in an area where it will not become wet or damp and do not spray any liquid on the battery. Store the battery in a safe place out of the reach of children and pets.

If the battery has been stored for an extended period of time, even if it has been periodically charged, it should be fully charged before using it in the e-bike.

Particularly high and particularly low ambient temperatures can permanently speed up battery wear or even damage the rechargeable battery. The rechargeable battery is subject to a certain degree of wear. Refer to the manufacturer's warranty terms for exact charge/discharge cycle specifications and corresponding power loss figures.

Maintain the battery and the charger as directed by the manufacturer's instructions.

### **WARNING**

In the event of a malfunction of the drivetrain and/or battery, the components may become hot. Shut off the e-bike or charger and do not touch any of the components until they have cooled down.

## Charger and Power Supply

### **WARNING**

Failure to follow the instructions in this section may result in damage to electrical components on your bicycle and will void your warranty, but most importantly, may result in serious personal injury or death. If your battery or charger exhibits any signs of damage, do not use it and immediately bring it to an authorized retailer for inspection.

When charging the battery, place the charger and battery on a stable, level surface unaffected by heat. You should charge the battery in a dry, well-ventilated area and make sure the charger is uncovered during the charging process. Ensure that the battery and charger are not exposed to any flammable or dangerous substances. Plug the charger into an outlet (100-240V), using the appropriate plug for the country's standards, then connect the charging plug with the charging socket on the battery.

Montague recommends charging the battery in an area with a working smoke detector.

- Inspect the charger regularly for damage prior to using. Do not use a charger that appears damaged.
- Verify that the charger and battery are clean and dry before charging the battery.
- Charge the battery on a fire-proof material in a dry, well-ventilated area with a smoke detector. Make sure that the battery and charger are uncovered during the charging process. Do not charge near any flammable or dangerous substances.
- Charge the battery at an ambient temperature between 32°F and 104°F (0°C and 40°C). If outside temperatures are too hot or too cold, charge the battery inside. For safety reasons, if the battery is too hot or too cold, it will not charge.

- Confirm that the charger and A/C outlet are the same voltage and use the appropriate plug for each country's electrical standards.
- While charging the battery, do not leave it unattended.
- When removing the battery charger power plug from the outlet or the charging plug from the battery, do not pull it out by the cord.
- Store the charger in an area where it will not become wet or damp and do not spray any liquid on the charger.
- Do not modify, open or disassemble the charger. Modification or disassembly may result in a short circuit, fire or malfunction and will void your warranty.

### **WARNING**

Do not modify the drive system, battery, or charger in any way for any reason. Doing so will void the warranty and can result in severe damage, faulty or dangerous operating conditions, and/or violation of local laws.

Please review the enclosed supplementary drive-assist manual for additional information about the charger and the battery.

Dealers and Owners **MUST NOT** change, alter, or modify in any way the original components of the bicycle or drive-assist system (e.g the specified

sizing of the attached gear ratios (front/rear chain rings)). Attempts to “hot-rod” or “improve” the speed of the bike are dangerous to the rider. Use only specified manufacturer drive-assist service and replacement parts.

## **WARNING**

Allow the drive system and rechargeable battery to cool before touching to prevent risk of being burned.

## **WARNING**

Do not leave the battery connected to the charger for extended periods after the battery is charged.

## **Tips for Getting the Most Range from Your Battery**

The drive is an auxiliary motor and works most efficiently at a cadence of 50-80 crank revolutions/minute. You can get the most mileage out of a new and fully charged battery.

Because the range is dependent on a variety of factors such as the level of assistance, speed, shifting behavior, tires and tire pressure, age and condition of the rechargeable battery, route profile and conditions, headwind and ambient temperature as well as the weight of the e-bike, rider and luggage, it is not possible to accurately predict the range before setting off or during a ride.

In general however, the higher the power mode, more resistance created by inclines, terrain, wind and weight on the e-bike, and frequent stopping and starting will consume more energy and will reduce the range of the battery.

To improve range from your battery:

- Shift to a lower or higher gear before inclines and descents to avoid excessively fast or slow cadences.
- Operate the gear shifting system as if you were riding without assistance.
- Use the lower gears in your gear shifting system on inclines, in headwinds and with heavy loads.
- When starting from a complete stop, begin in the lowest gear.
- Always ride in a low gear and pedal as hard as possible to use less battery power.
- Shift down to a lower gear before reaching an incline.
- Look ahead and anticipate while riding so that you can avoid unnecessary stops.
- Where possible, ride on surfaced roads and paths.
- Do not transport unnecessary loads.
- Take care of the e-bike on a regular basis and check the tire pressure regularly.
- Observe maintenance periods.

- Continually test the functionality of the e-bike and check for wear, and refer to all notes on the rechargeable battery in this user manual and the drive system manual.
- Keep the e-bike and components clean.
- Store the battery at room temperature prior to riding.
- Follow the instructions regarding the temperature range for storage of the battery.
- Do not insert the battery into the casing until just before you ride.
- If any part of any component of the drivetrain is wet, allow it to dry completely before connecting the charger.
- Do not use a pressure washer or dry with compressed air. This will force contaminants into sealed areas, electrical connections/components promoting corrosion, immediately damaging, or result in accelerated wear.
- Do not use alcohol, solvents or abrasive cleaners to clean the battery or charger.
- For instructions on how to clean drivetrain components, please refer to the supplementary drive-assist manual for the drivetrain manufacturer's instructions. Make sure connectors are dry and clean before reconnecting and riding.

## Cleaning, Storing, and Transporting your E-bike

When not riding, turn the drive system off and remove the battery to prevent unauthorized use. Remove the battery and key when the bike is parked for long periods of time.

### Cleaning

#### **WARNING**

Keep water away from the electrical components.

Use a damp sponge with only a mild soap and water solution. Rinse the sponge often. Do not spray water directly on controls or drive system components.

- Use a soft brush to remove dry contamination.

#### **WARNING**

Remove the battery from the e-bike before cleaning. Make sure no electrical component is connected or on as you may be injured.

#### **WARNING**

Make sure the bike is secured upright and can not fall over accidentally while you are cleaning it. Don't rely on the kickstand. Use a sturdy portable bicycle wheel stand to hold the bike upright.

## Storage

- Store your e-bike in a dry, well ventilated area. Only store the battery at an ambient temperature below +95°F (+35°C).
- Clean your e-bike prior to storing for an extended period of time and protect it from moisture, dirt, dust and other contaminants during storage.
- If the bicycle or battery are stored and not in use for extended periods of time, be sure to charge the battery at least every three (3) months so at least 3 LEDs (60%) are glowing blue. If the battery is not charged over a period longer than three months, it can cause damage to the battery.
- If the battery has been stored for an extended period of time, even if it has been periodically charged, it should be fully charged before using it in the e-bike.
- Store the rechargeable battery out of reach of children and animals, and in such a way that it cannot fall down.
- Do not expose your bicycle to prolonged excessive heat (e.g. direct sunlight) such as inside a car parked in the sun or near a heat source such as a radiator.
- If your bicycle is exposed to cooler temperatures, keep the bicycle stored indoors until just before riding.

## Transportation

### **WARNING**

Always remove the battery before transporting your e-bike. The battery is considered dangerous and is subject to hazardous materials regulation. It will require special packaging and labeling for certain forms of transportation and may be limited as to how it may be transported.

You are responsible for knowing and following the legal requirements of transporting your battery. Consult shipping experts to determine the appropriate methods of shipping your battery and e-bike including any legal insulation or packaging requirements.

### **CAUTION**

Use caution when handling the bicycle (including, but not limited to parking, lifting, pushing, loading it into a car or onto a bicycle carrier and unloading).

- If you use a bike carrier, confirm that it is able to carry your e-bike.
- When carrying the battery outside the frame, consider using an approved battery transport box. Make sure the battery is secured while transporting to prevent damage to the battery or collision with other items.

- Avoid transporting the rechargeable battery by car in high outdoor temperatures. Ensure that you park the car in the shade when transporting the rechargeable battery by car.

If traveling by rail, air or ferry, confirm with the carrier well in advance of your departure as to the legal requirements of traveling with your e-bike. The lithium ion battery is considered hazardous goods. You may need to ship the battery or e-bike separately with legally appropriate packaging and labeling.

## Keys

The rechargeable battery is unlocked and removed using a key. Keys are identified by the serial number engraved on the key. Please record the key serial number for future use and key replacement. If your keys are ever lost or stolen, or you would like additional spares, please contact the key provider.

After lots of rides and washing, the battery lock can become dry and difficult to use. To maintain, whenever you lubricate your bike chain, place a few drops of chain oil on the key insert the key and operate the lock, then remove and wipe the key clean.

## Disposal

Do not dispose of the battery or charger in your household waste. All parts of the e-bike must be disposed of in accordance with the laws and regulations in your country, state or municipality. It is your responsibility to know and comply with such laws and regulations.

Lithium-ion rechargeable batteries are potentially dangerous and considered hazardous waste and, as such, are subject to all country, state, regional and municipal laws and regulations regarding their disposal. Familiarize yourself with the laws and regulations and if appropriate, take it to a collection location or a recycling center.

Do not dispose of your e-bike or charger in household waste. Once the rechargeable battery has been removed, due to the electrical components the e-bike and charger may be considered electrical waste or electronic equipment. As such, disposal may be subject to all country, state, regional and municipal laws and regulations regarding disposal. Familiarize yourself with the laws and regulations and if appropriate, take it to a collection location or a recycling center.



# PROPER MAINTENANCE AND ADJUSTMENT

## **! WARNING**

DO NOT attempt to perform any adjustments while riding your e-bike.

This chapter lists instructions for adjustment of some the parts of an e-bike. After a repair, examine the e-bike as shown in the Before Each Ride Checklist on page 15. This manual is not intended to be a repair manual. If you are unsure about adjusting your e-bike or have any questions about adjusting your e-bike, transport it to your local dealer for adjustments and repairs.

## **! WARNING**

A bicycle that malfunctions could decrease your control and cause you to fall. Fully examine all parts of the bicycle before each ride. If there is a problem, do not ride the bicycle, but take it to your local bike dealer for inspection and repair.

## Torque Specifications

Torque is a measure of the tightness of a screw or bolt. Use a torque wrench to make sure you do not apply too much torque, which can cause damage to or break the part. However, a fastener that is too loose can also cause damage.

After you use the torque wrench, examine the function of the part with the tests in this section. If a part does not have the correct function when it is tightened to the recommended torque, transport your e-bike to your dealer for repair.

## **! WARNING**

Incorrect torque can cause damage or break a part. Use a torque wrench to correctly tighten a part, or transport the bicycle to your dealer for service.

It is important to use only genuine replacement parts with dimensions identical to the original components on your bike. The Montague frame quick release and the foldable stem assembly are both safety-critical components. Only replace the frame quick release and the foldable stem with a genuine part sourced from Montague.

If you replace the crank or tires with different models, you should use caution as there is a possible reduction of toe-clearance and the possibility of pedal contact with the ground may be increased.

## Handlebars

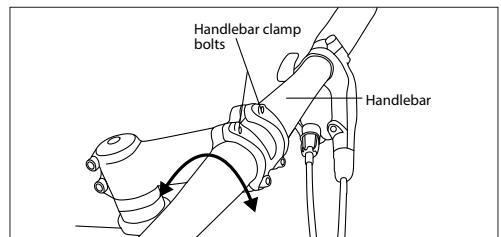

Fig. 47: Handlebar bolts on threadless stem

To rotate the angle of your handlebar:

1. Decrease the tightness of the handlebar clamp bolts on the stem (Fig. 47).

2. Twist the handlebar by rotating it forward or backward. Make sure it remains in the center of the stem (Fig. 18 page 30).
3. Tighten the handlebar clamp bolts on your type of stem: Welded stems: 100-120 lb•in (11.3-13.6 N•m). Forged Stems: 150-180 lb•in (17-20.3 N•m).

## Stem

Your Montague e-bike comes equipped with a stem that folds down to create the smallest folded bike size possible. The mounting and adjustment of this stem is unique to Montague. Please read the instructions below carefully before attempting to adjust the stem.

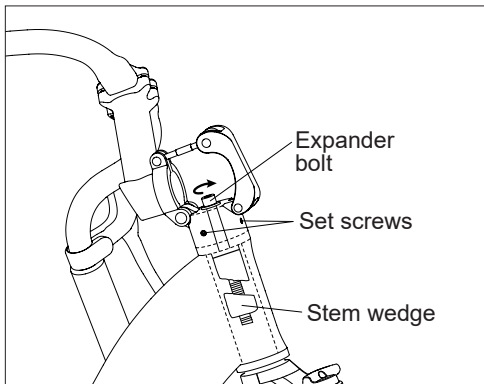

Fig. 48: Stem mounting parts.

### To align or adjust the stem:

1. Open the stem quick release, and begin to fold the handlebars down (Fig. 36, page 37). This will provide access to the expander bolt.

2. Decrease the tightness of the expander bolt by two or three turns (Fig 48).
3. Decrease the tightness of all (4) set screws by two or three turns (Fig 48).
4. Fold the handlebars back to the upright position, and close the stem quick release. This will allow you to properly align the stem with the front wheel.
5. With the stem aligned parallel with the front wheel, apply a clamping force between the top of the stem assembly and the fork crown. This will press the stem down onto the headset bearings (Fig 49).

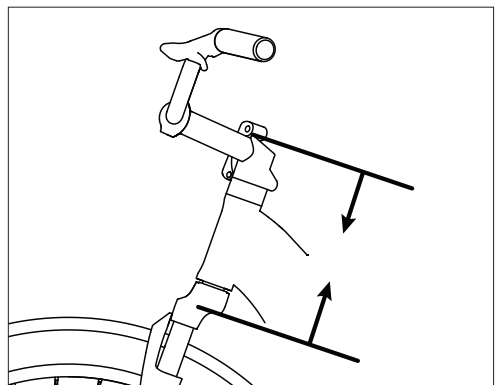

Fig. 49: Apply clamping force to tension headset

6. While applying the clamping force, tighten all (4) set screws around the bottom of the stem. This will temporarily hold the stem in place until the expander bolt can be tightened (Fig 48).

- Open the stem quick release and begin to fold the handlebars down to provide access to the expander bolt.
- Tighten the expander bolt to 120 lb•in (13.6 N•m).
- Fold the handlebars back to the upright position, and close the stem quick release.

## **! WARNING**

If you complete these adjustments and the quick release is tight, yet the handlebars feel loose, do not ride your bike. Take it to your local dealer for inspection and adjustment.

## Seat (Saddle) Adjustments

## **! WARNING**

If you ride a saddle that is not adjusted correctly or one that does not correctly support your pelvic area, it can cause injury to your nerves and blood vessels. If your saddle causes pain or numbness, adjust the saddle position or speak to your dealer about a saddle that is more comfortable.

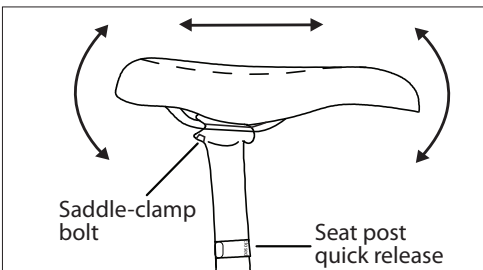

Fig. 50: Saddle bolts and adjustments.

Saddle angles can be adjusted to meet your preferences. It is recommended that you first try to ride with the top of the saddle parallel to the ground. The saddle can also be moved forward or rearwards along the seatpost to adjust the distance from the handlebar.

### To adjust the angle of the saddle:

- Decrease the tightness of the saddle-clamp bolt (Fig. 50) until the saddle can be moved.
- Put a straight edge, bubble level or ruler across the top of the saddle to better see the angle of the saddle.
- Adjust the saddle and tighten the saddle-clamp bolt for your type of seatpost:

- One bolt that uses a 13 or 14 mm open-end wrench: 180-220 lb•in (20.3-24.9 N•m)
- One bolt across the seatpost head that uses a 5mm allen wrench: 120-130 lb•in (13.6-14.7 N•m)
- One bolt that uses a 6mm allen wrench: 150-250 lb•in (17-28.3 N•m)
- Two bolts that use a 5mm allen wrench: 80-120 lb•in (9.6-14.1 N•m)

## **! WARNING**

An incorrectly positioned seatpost can break the saddle rails or the seat-clamp bolt, and cause you to fall. Only clamp the flat portion of the saddle rails in the seat clamp.

For saddle height adjustment and seatpost quick release usage, see page 32, Installing the Seatpost.

## **! WARNING**

A seatpost that is too high can cause damage to the bicycle, decrease your control, and cause you to fall. Make sure the minimum-insertion mark (Fig. 25 page 33) is in the frame.

## **Pedals**

The right pedal (chainside) is threaded in the standard clockwise to tighten direction. The left pedal is threaded in the opposite direction (Fig. 26, page 33). Tighten pedals into the crankarms to 350-380 lb•in (40.2-42.9 N•m).

The adjustment of pedal bearings requires special tools and training. Only a bicycle dealer should attempt these adjustments.

## **Control Cables**

Examine all cables for kinks, rust, broken strands, or frayed ends. Also examine the cable housing for loose wire strands, bent ends, cuts, and worn areas. If you think there is a problem with a cable or housing, replace the cable before riding.

## **Rear Derailleur Adjustment**

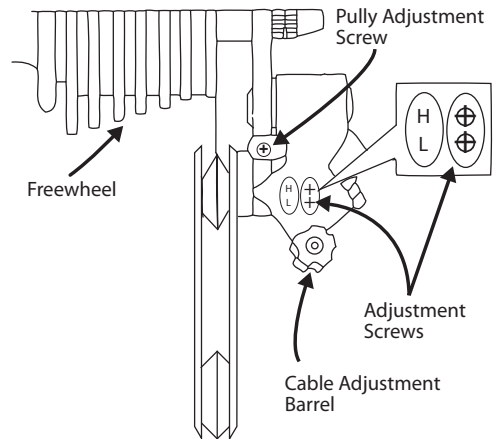

Fig. 51: Rear derailleur parts. View from the rear.

If the gear system is not functioning properly, check to ensure that the rear derailleur follows each shifting command of the right twist shifter/shift lever. Cable stretching could affect the function after some time, so that synchronization may no longer be assured. Position the bicycle in a stand and check and adjust as follows:

1. On models with a front derailleur, shift so that the chain is on the middle chainring, by turning the crank forward and shifting the left twist shifter/shift lever.

2. Shift the chain to the outermost/smallest rear sprocket by turning the right twist shifter all the way away from you, or moving the right shift lever all the way towards you.
3. While turning the crank forward, rotate the right twist shifter or push the right shift lever to the next position.
4. The chain should move to the second sprocket quickly and easily. If it stays on the first sprocket, the tension of the shifting cable must be increased (proceed to Step 6).

5. If the chain jumps across the second sprocket or if it scratches the third sprocket, the tension of the shifting cable must be decreased.

6. Cable tension is adjusted by turning the Cable Adjusting Barrel, which is located at the junction of the cable and the shifter or rear derailleur (Fig. 51). To increase tension, turn the knurled knob counterclockwise, to decrease tension, turn the knob clockwise. Turn until the problem is corrected.

If the tension is adjusted according to the above steps, the chain should follow all shifting commands on the shifters. If the gear system still does not function properly, please contact a bicycle dealer for assistance.

## Front Derailleur Adjustment

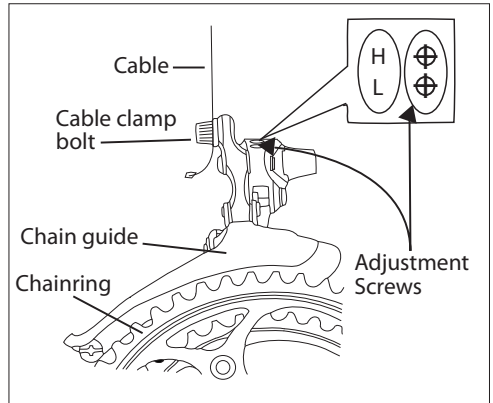

Fig. 52: Front Derailleur Adjustments.

With bicycles that have more than one chainring, the front derailleur makes gear changes.

### To adjust the small-chainring position

1. Move the chain to the smallest front chainring and the largest rear cog.
2. Decrease the tightness of the cable clamp bolt (Fig. 52) until the cable is free.
3. Turn the low-gear adjustment screw (identified with an "L") until the inner chain-guide of the derailleur is approximately 0.5 mm from the chain.
4. Pull on the cable end, and move the left shift lever to the small chainring position.

5. On the shift lever, fully turn clockwise the derailleur cable barrel-adjuster.
6. Put the cable in the groove found near the derailleur-cable-clamp bolt, pull the cable tight, and tighten the clamp bolt to 44-60 lb•in (5.0-6.8 N•m).

## To adjust the large-chainring position

1. Move the rear derailleur to the smallest rear cog.
2. Turn the high-gear adjustment screw (identified with an “H”) counterclockwise until it cannot stop the movement of the derailleur.
3. Turn the crankarms with your hand. Use the shifter to carefully move the chain to the outside chainring.
4. Move the outer chain-guide approximately 0.5mm from the chain.
5. Tighten the high-gear adjustment screw until it resists.

If you have turned the screw too far, the front derailleur will move to the small chainring.

6. Change gears to all the gear combinations. Make sure the chain does not come off when you move the shift lever. Make sure the derailleur cage does not rub on part of the crankarms.

## To adjust the middle-gear position with three chainrings

1. Move the chain to the largest front chainring and the smallest rear cog.
2. Turn the cable barrel-adjuster (on the shifter) to change the cable tension and align the inner cage of the derailleur until it touches the chain.
3. Change to all gear combinations to make sure the chain smoothly lines up with all the chainrings.

## Brakes

The brake system on your bike lets you slow and stop. The function of this system is crucial to your safety. It is strongly recommended that only your dealer adjust your brakes.

Each month, examine the brake pads for wear.

### To align a cable actuated disc brake

First adjust the clearance between the right (inside) brake pad and the disc.

1. Use a 5mm allen wrench to move the inside pad inward toward the disc rotor till it touches the rotor.
2. Back off slightly until the pad does not touch the rotor surface.

Next adjust the clearance between the left (outside) brake pad and the disc.

3. Turn the barrel adjuster located on

the front brake lever clockwise to move the outside brake pad inward until it touches the rotor.

4. Back off slightly (1/4 turn) until the pad does not touch the rotor surface and the wheel spins freely.

If there is contact between the brake pads and rotor after performing the above steps bring your bike to your local dealer for adjustment.

## Hydraulic Disc Brake

Maintaining hydraulic disc brakes requires purpose built bleed kits and extensive training. Please bring your bike to a professional bicycle mechanic for hydraulic disc brake adjustment and repair.

### **WARNING**

When you apply the brake, the brake pads remove material from the disc rotor. If the brakes remove too much material, the rotor can become weak and sudden failure can ensue. Examine the rotors regularly and replace them when they are worn.

## Wheels

Examine tires for worn areas, bulges, and damage. Make sure rims are clean. Make sure tires are inflated to proper specifications as listed on the sidewall of the tire. If the wear-indicators on the brake surface show the rim is worn,

replace the rim. Make sure there are no loose or damaged spokes. If loose or damaged spokes are found, do not ride the bicycle, take it to your local bike dealer for repair.

### **WARNING**

Riding with an improperly adjusted wheel quick release can allow the wheel to wobble or disengage from the bicycle, causing damage to the bicycle, and serious injury or death to the rider.

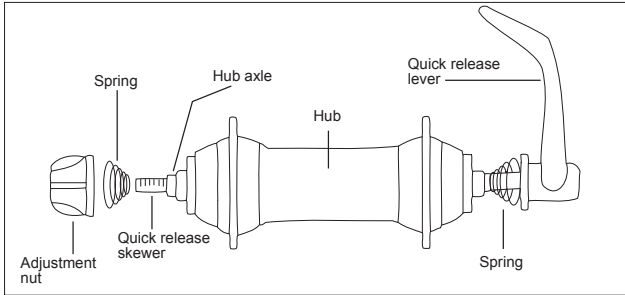

Fig. 53: Traditional quick release; diagram of parts.

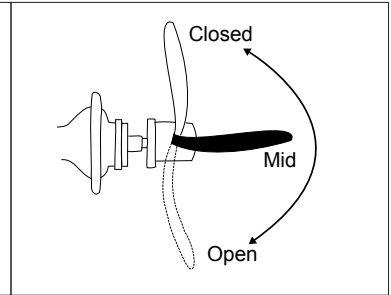

Fig. 54: Positions of a quick release.

## Wheel installation

### **! WARNING**

**DO NOT** change or swap wheels between different bicycles. Your wheels may not engage the other bicycle's fork correctly causing an accident.

Your Montague bicycle could use two different types of wheel attachment devices. Carefully read the instructions for the devices on your bicycle.

- Traditional quick-release
- Threaded axle and nut

### To install a wheel with a traditional quick-release

1. Move the quick release lever to the OPEN position (Fig. 54) and set the wheel so it fully engages the frame dropouts.
2. With the lever in the MID position (Fig. 54), tighten the adjusting nut (Fig. 53) until it is slightly tight.

3. Move the quick release into the closed position (Fig. 54) with the palm of your hand.
4. A properly closed quick release lever should leave a mark on the palm of your hand from closing.
5. If you can lock the lever with little or no resistance, the clamp-force is not sufficient. Go back to step 2 and tighten the adjustment nut 1/4 turn and return to step 3.
6. Examine for correct quick release adjustment. With the quick release closed, lift the bicycle and hit the top of the tire with a solid blow (Fig. 9 page 28). The wheel should not come off, be loose, or move from side to side.

### To remove a wheel with a traditional quick-release:

1. Open quick release lever (Fig. 54).
2. Decrease the tightness of the adjustment nut; turn it approximately three full turns.



3. Move wheel out of the fork or frame.

## **To install a wheel with a threaded axle and nut:**

Some rear wheels are attached with nuts threaded on the axle. A toothed washer could be necessary between the nut and bicycle frame.

1. Tighten the rear wheel axle nuts: 240-300 lb•in (27.1-33.9 N•m).
2. Make sure you have correctly attached the wheel. Lift the bicycle, and hit the top of the tire with a solid blow (Fig. 9, page 28). The wheel should not come off, be loose, or move from side to side.
3. If the wheel connection fails the test, do these procedures again. If you cannot correctly attach the wheel, transport your bicycle to your dealer for repair.

## **Cassette and Freehub Adjustments**

Cassette and freehub adjustments require special tools and training and should only be performed by your local bicycle dealer.

Tighten freehub body:

354 lb•in (40 N•m).

Tighten cassette sprocket lockring:

347 lb•in (39 N•m).

## **Fitted Accessories (Racks and Fenders)**

In addition to the parts already discussed in this chapter, your bicycle might have accessories such as fenders, lights, racks, chain guard, or kickstand. Each month, check the accessories to make sure they are correctly attached. If the part is loose or not in alignment, adjust or tighten the part, or take your bicycle to your dealer for service.

If you are attaching additional aftermarket accessories to your e-bike, make sure your e-bike is suitable for the attachment of those accessories. Read and follow the instructions that came with each accessory.

## **Only Install Compatible Accessories**

Not all accessories are compatible or safe, so only add accessories that have the approval of the manufacturer. As an example, some panniers or bags can put weight high on the e-bike. This can make your e-bike less stable. Although some bags are compatible with some of our e-bikes, always check with your dealer before making any change to your e-bike. As another example, clamping anything on a carbon part can weaken or damage the part.

## **WARNING**

Any modification can make your frame, fork, or part unsafe. Do not sand, drill, file, remove redundant retention devices, install incompatible forks, or make other modifications. A component that is not approved or assembly that is not correct can put high stress on your e-bike or components. A frame, fork, or component with modifications could decrease your control and cause you to fall. Before you add an accessory to your e-bike or change a part of your e-bike, speak to your dealer.

## **Bearing Adjustments**

Adjustments to bearing systems found on your e-bike require special training. If your e-bike requires adjustment to the bearings, take it to your local bicycle dealer.

## **Lubrication**

This section shows the parts that you should lubricate, the frequency of service, and brief instructions. See your dealer for recommended grease or oil. If more instructions are necessary, see other sections of this manual or consult your dealer.

To service bearings, special tools and training are necessary, so only your dealer should do this. Some bearings are permanently sealed and do not require new grease each year.

## **Stem**

Each year apply lubricant to the stem. To apply lubricant to a direct-connect stem, adjustment of the headset bearings is necessary. Only your dealer should do this.

To apply lubricant to a quill stem:

1. Remove the stem from the frame.
2. Clean the used grease from the stem.
3. Apply a thin layer of grease to the section of the stem-quill that will be put into the frame. Also apply grease to the stem wedge.
4. Install the stem.

## **Seatpost**

Each year apply lubricant. Use the procedure for your frame and seatpost materials:

For a metal seatpost in a metal frame

1. Loosen the seatpost binder bolt, or release the quick-release, and remove the seatpost from the frame.
2. Clean the used grease off the seatpost.
3. Apply a thin layer of grease to the section of the seatpost that will be in the frame.

4. Put the seatpost into the frame.
5. Adjust the saddle to the correct height and align it. Tighten the seatpost binder-bolt or lock the quick-release.
2. Apply a thin layer of grease on the threads.
3. Install the pedals on the correct side; put the right pedal on the right crankarm and the left pedal on the left crankarm.

## Bottom Bracket

Each year, replace the grease in the bottom bracket bearings. To service bearings, special tools and training are necessary, so only your dealer should do this.

## Chain

Each month, apply lubricant to the chain. Always place a rag behind the chain to prevent lubricant on other parts of the bicycle. After you apply lubricant, wipe off the excess with a rag.

## Pedals

Each year, replace the grease in the pedal bearings. To service bearings, special tools and training are necessary, so only your dealer should do this.

Each year replace the grease on the pedal axles where they thread into the crank arms. There are right and left pedals, usually identified with a letter on the end of the pedal axle or on the wrench flats.

1. Remove the pedal-axles from the crankarms; turn the right pedal-axle counterclockwise, but turn the left pedal-axle clockwise.

4. Tighten the pedal-axles.

## Derailleurs

Each month, apply lubricant to all pivot points on the front and rear derailleurs, together with the derailleur pulleys on the rear derailleur.

## Headset

Each year, replace the grease in the headset bearings. To service bearings, special tools and training are necessary, so only your dealer should do this.

## Brakes and Brake-levers

Each three months apply lubricant to the brake-lever pivots and brake arm fixing pivots.

## Wheels

Each year, replace the grease in the wheel bearings. To service bearings, special tools and training are necessary, so only your dealer should do this.

Each year, apply lubricant to wheel quick-releases. Apply two or three drops of synthetic lubricant or a light oil where the quick-release lever turns in the quick-release body.

## Suspension Forks

Each month, lubricate your suspension fork. Refer to the supplementary manual provided by the fork maker, or consult your dealer.

Each year, replace the oil in your suspension fork. To replace the oil, special tools and training are necessary, so only your dealer should do this.

## Cables

Apply lubricant to a cable when you install it.

To install a cable in a cantilever brake, special tools and training are necessary, so only your dealer should do this.

To install a cable

1. Before you remove the used cable, note its path on the frame. Loosen the cable-clamp bolt, and remove the worn cable.
2. Apply grease to the new cable where it passes through housing or guides. Install the new cable on the same path as the used cable.
3. Make sure the leaded end of the cable is installed correctly in the lever. Make sure the housing is correctly installed in the housing stop of the lever. • If necessary when you install a cable in a brake, adjust the brake again.
4. Turn the barrel-adjuster clockwise so that the threads on the barrel-adjuster do not show. • For a derailleur cable, put the shift-lever in the position with the least cable tension. • For a brake cable, hold the brake closed while you do the subsequent step.
5. Tighten the cable-clamp bolt to 52-69 lb•in (6-8 Nm).
6. Cut the cable so that no more than 2" (51 mm) extends through the clamp-bolt.
7. Put a metal cap or put a bit of solder on the end of the cable to prevent a frayed cable.

# MAINTENANCE SCHEDULE

Many of the items scheduled on the maintenance list are described within this manual. Several items on this maintenance list require special tools and training to complete. We recommend that you bring your bicycle to your local bike dealer to ensure these items are completed correctly.

## Before Each Ride

- Examine the frame and fork
- Examine the wheels
- Examine tire inflation
- Examine the brakes
- Examine the handlebar and stem
- Examine the saddle and seatpost
- Examine lights and reflectors
- Ensure pedals are on tight
- Ensure all quick releases are clamping properly
  
- Check battery charge level
- Check the lock for the battery
- Visually check the rechargeable battery for damage
- Visually check the drive train for damage and check the operation of the system
- Visually check whether cables and connectors are securely in place and look for damage
- If you discover any missing or damaged parts, do not use the e-bike. Have an authorized dealer repair your e-bike

## Each Week

- Clean bicycle with a damp cloth
- Examine wheels for loose spokes
- Apply lubricant to suspension forks

## Every Month

- Examine the attachment of the handlebar and stem
- Examine the attachment of the saddle and seatpost
- Examine the chain
- Examine the cables for wear
- Examine the operation of the shift levers and derailleurs
- Lubricate derailleurs
- Examine headset bearing adjustment
- Examine brake pads
- Examine attachment of brakepads
- Examine chain tension
- Examine wheel bearing adjustment
- Examine rims and tires for wear
- Lubricate brake levers
- Examine crankset and bottom bracket
- Examine the attachment of accessories

## Every Year

- Bring in bicycle for full inspection by your dealer
- Lubricate handlebar stem
- Lubricate seatpost
- Replace grease in the pedal threads and bearings
- Replace grease in the wheel bearings
- Replace grease in the headset bearings
- Replace grease in bottom bracket
- Lubricate wheel quick releases
- Replace grease and oil in suspension forks

# MONTAGUE CORPORATION LIMITED WARRANTY

Montague Corporation warrants each new Montague electric bicycle frame against defects in workmanship and materials for 5 years from the date of purchase for the original owner.

Montague Corporation also warrants all original parts, excluding suspension forks and drive-assist parts, for a period of one year from the date of purchase. Forks and drive-assist system parts shall be covered by the stated warranty of their original manufacturers. Paint and decals are warranted for one year. This warranty is expressly limited to the repair or replacement of a defective frame, fork, or defective part and is the sole remedy of the warranty. This warranty is not transferable from the original owner.

Montague Corporation does not make any promise, representation or warranty regarding the use of this e-bike.

Failure to follow the instructions and warnings in this manual may invalidate the warranty. Improper maintenance, use of the e-bike, the battery or charger will invalidate the warranty(ies) provided

The applicable statutory warranty provisions will be those for the country in which the product was purchased.

Any modification or attempted modification of the drive train system, power-output is prohibited and will void the warranty.

Claims must be made through an authorized Montague dealer. Proof of purchase is required. In addition,

a warranty registration card or online registration must be completed and received by Montague Corporation before a warranty claim may be processed.

This warranty does not cover normal wear and tear, improper assembly, damage or failure due to accident, misuse, abuse or neglect, follow-up maintenance, labor charges for parts replacement or changeover, or installation of parts or accessories not originally intended or compatible with the bicycle as it was sold. Modification of the frame or components shall void this warranty.

Montague Corporation shall not be responsible for incidental or consequential damages. Some states do not allow the exclusion of incidental or consequential damages, so the above exclusion may not apply to you.

Labor charges for parts changeovers are not covered by the warranty.

This warranty gives the consumer specific legal rights, and those rights may vary from place to place. This warranty does not affect the statutory rights of the consumer.

This warranty is expressly limited to the repair or replacement of a defective item and is the sole remedy of the warranty. This warranty extends from the date of purchase, applies only to the original owner, and is not transferable.

© 2020 Montague Corporation, Cambridge, MA 02141 USA. **Montague** is a registered Trademark of the Montague Corporation.

Component specifications vary by country and are subject to change without notice. All Montague bicycles are covered under one or more patents or patents pending. **CLIX** is a registered Trademark of CLIX Systems, Inc.





Montague Corporation  
P.O. Box 398032  
Cambridge, MA 02139  
Phone # +1 617-491-7200  
[www.montaguebikes.com](http://www.montaguebikes.com)

© 2020 Montague Corporation, Cambridge, MA, USA







From: \_\_\_\_\_

\_\_\_\_\_

\_\_\_\_\_

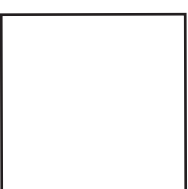

**MONTAGUE CORPORATION**

P.O. Box 398032

Cambridge, MA 02139