



ENVO

ELECTRIC SNOWBIKE KIT

USER MANUAL

+1 (604) 423-3381

ENVODRIVE.COM

TABLE OF CONTENTS

1. INTRODUCTION	4	6. OPERATING YOUR PRODUCT	34
1.1. Use of Manual	4	6.1. LCD Function Overview	34
1.2. Service & Technical Support	4	6.2. Display Content	35
1.3. Illustrations	4	6.3. Button Definition	35
2. RIDER SAFETY	5	6.4. Normal Operation	36
2.1. Overview	5	6.5. Error Codes	40
2.2. Rider Position	6	6.6. General Project Setting	41
2.3. Stay Clear Of Snow Track	7	6.7. P Parameter Setting	42
2.4. Riding Gear	7	6.8. C Parameter Setting	43
2.5. Safety Gear	8	6.9. Hand Throttle Control	44
2.6. Driver Awareness	8	6.10. Operating Range	44
2.7. Excessive Speed	8	6.11. Maximize your Range	45
2.8. Obstacles and Jumping	8	7. MAINTENANCE & REPAIR	46
2.9. Unseen Obstructions	9	7.1. Maintaining Parts	46
2.10. Hand Signaling	9	7.2. In Case of Accident	46
2.11. Trails	9	7.3. Troubleshooting Table	48
2.12. Riding at Night	9	8. TRANSPORTATION & STORAGE	51
2.13. Riding In a Group	9	8.1. Transportation	51
2.14. Terrain & Weather Conditions	10	8.2. Storage	51
2.15. Avalanche Hazard	12	9. GENERAL TERMS & WARRANTY	52
2.16. Avalanche Danger Scale	12	9.1. Warranty	52
2.17. Windchill Chart	13	9.2. Warranty Terms	53
3. BATTERY & CHARGER SAFETY	14	9.3. Registering Product Warranty	54
3.1. Overview	14	9.4. Liability Disclaimer	54
3.2. First Charge	14	9.5. Exclusions	54
3.3. Charging Your Battery	15	9.6. Satisfaction Guarantee	54
3.4. Battery And Charger Care	15	9.7. Customer Service	55
3.5. Battery Maintenance	16	9.8. Troubleshooting & Technical	55
3.6. Battery Transport	17	10. CONTACT	56
3.7. Battery Disposal	17		
4. PRODUCT DESCRIPTION	18		
4.1. Components	18		
4.2. Dimensional Overview	19		
5. ASSEMBLY INSTRUCTIONS	21		
5.1. Unboxing	21		
5.2. Rear Snow Track Assembly	22		
5.3. Front Fork Connector Assembly	28		
5.4. LCD Installation	32		

⚠️ WARNING

Read, understand, and follow all of the instructions and safety precautions in this manual and on all product labels. Failure to follow the safety precautions could result in serious injury or death.

IMPORTANT NOTE TO BUYERS

This is a DIY product preliminary launch for early adopters. This concept has gone through all major engineering, prototyping, limited production, testing, revisions, and approval in order to be released to market. However, there might be multiple unknown failure scenarios during the use of this product as mobility means the product will be used on various terrains in which the risks are assumed by the user. That means the buyer, assembler and users must be mechanically inclined and fully understand the product details and instructions as well as all probable risks of using them. DIY installation on a wide range of bicycles requires a creative and a technical mind. Failure to properly install the product may cause serious damage to the bike and/or severe injury. The buyer assumes the liability for the safe installation and use of this product by signing the Liability Waiver. If you have any questions or need further details, do not hesitate to contact us.

All information contained within this user manual is based on the latest product information at the time of publication. Due to constant improvements in the design and quality of production components, some minor discrepancies may result between the actual vehicle and the information presented in this publication. Depictions and/or procedures in this publication are intended for reference use only. No liability can be accepted for omissions or inaccuracies. Any reprinting or reuse of the depictions and/or procedures contained within, whether whole or in part, is prohibited.

1. INTRODUCTION

WELCOME TO THE ENVO FAMILY

Congratulations! You are now the proud owner of an ENVO Electric SnowBike Kit. Creating this product has been a long yet rewarding journey, and we are excited to share our innovation with the world. With the ENVO Electric SnowBike Kit you can turn any standard bicycle into a powerful electric snow machine capable of moving swiftly and smoothly through the snow. We know that if you purchased this kit you share our enthusiasm for imaginative mobile solutions, and we sincerely hope it sparks your creativity. At ENVO, we are committed to developing sustainable zero emission mobility systems and work hard to maintain the satisfaction of our customers. Please stay connected and share anything that can help us improve our products and service.

1.1. USE OF MANUAL

For safe and enjoyable operation and installation of all ENVO Drive Systems products please carefully read and follow the recommendations outlined in this manual. It is critical that you clearly understand all general operations of various parts of your ENVO Drive Systems product.

Please pay extra attention to any information marked with a caution or warning symbol:

⚠ WARNING

⚠ CAUTION

1.2. SERVICE & TECHNICAL SUPPORT

Please contact us regarding any technical issues that you encounter, we are here to help. Give us a call, visit our help centre at support.envodrive.com, or refer to the tutorial videos on our website. This manual is not intended to be an extensive service guide.

1.3. ILLUSTRATIONS

The illustrations in this manual may not be perfect representations of your ENVO Electric SnowBike Kit, and some of the components may differ. The models illustrated are for instructional purposes only.

2. RIDER SAFETY

2.1. OVERVIEW

Follow the instructions provided in the manual and ensure that all critical components of the SnowBike Kit are inspected thoroughly before installation and riding.

WARNING

Riding a SnowBike requires your full attention. Do not drink alcohol or consume drugs before or while riding. Drugs and alcohol will reduce your alertness and slow your reaction time. SnowBikes are capable of traveling at high speeds. Use extra caution to ensure operator safety. Make sure your SnowBike is in excellent operating condition at all times. Always check major and vital safety components before every ride.

The ENVO Drive Systems SnowBike Kit is designed and tested to provide safe operation when used as directed. Failure of critical machine components may result from operation with any modifications, especially those that increase speed or power. **Do not modify your SnowBike Kit.** Loss of control may occur at higher speeds. Modification may also create a safety hazard and lead to serious injury.

The warranty of your entire machine is terminated if any equipment has been added, or any modifications have been made to increase the speed or power of the SnowBike.

WARNING

The ENVO SnowBike Kit can be dangerous to use. The user or consumer assumes all risk of personal injuries, damage, or failure of the bicycle or system and all other losses or damages to themselves and others and to any property, arising out of or as a result of installing the ENVO SnowBike Kit.

As with all mechanical components, your SnowBike is subjected to wear and high stresses. Different materials and components may react to wear or stress fatigue in different ways. If the design life of a component has been exceeded, it may suddenly fail, possibly causing injuries to the rider. Any form of crack, scratches or change of coloring in highly stressed areas indicate the life of the component has been reached and should be replaced.

⚠️ WARNING

Once installed your ENVO Electric SnowBike Kit, like any other ebike, require regular maintenance by mechanically inclined persons to guarantee safety of use. Screws and nuts are subject to become loose due to road vibration, especially within the first few kilometers of use. Make sure you inspect your bike often and have it serviced by a professional regularly.

- Always ride at a speed that's appropriate for the conditions. Higher speed means higher risk
- Ensure brakes and motor cut off switch are working prior to every ride
- Ensure nothing is loose (ie bolts, battery, snowtrack, snowboard, pedals, and handlebar) and everything is secured on the bike prior to every ride
- Always keep the brakes covered, and be prepared to stop in case of emergency
- Apply both brakes simultaneously and smoothly
- Never ride with headphones. They mask traffic sounds and emergency vehicles sirens, distract you from concentrating on what is going on around you. Headphone wires can tangle in the moving parts of the SnowBike, causing you to lose control

2.2. RIDER POSITION

Rider positions may vary with experience, but under many conditions, the proper position is to be seated with both feet on the pedals and both hands on the handlebar grips, for proper throttle, brake and steering control.

⚠️ WARNING

Improper riding position may reduce control and could result in serious injury or death. Always ride in a position that allows for complete control of your SnowBike.

⚠️ WARNING

The pedal assist is activated as soon as you spin the pedals or stimulate the throttle, make sure you are firmly seated on the bike and have at least one brake engaged prior to engaging the motor. Failure to do so may result in injury or even death.

2.3. STAY CLEAR OF SNOW TRACK

The SnowBike is operated through rotating snow track. Do not hold the track after assembly. Never sit or lean on the snow track.

WARNING

Serious injuries may result if feet, hands, or clothing become entangled in the snow track. Be alert when riding, and remain properly seated to stay clear of the track. A loose track could cause serious injury or death. We recommend checking the tightness of the snow track before riding.

WARNING

Do not use the SnowBike to tow objects or people, doing so may cause damage to property, serious injury, or death.

2.4. RIDING GEAR

HELMET

Wearing a helmet can prevent a severe head injury. Always wear a helmet that meets or exceeds established safety standards when riding any ENVO Drive Systems product.

EYE PROTECTION

Do not depend on eyeglasses or sunglasses for eye protection. Always wear shatterproof goggles or use a shatterproof helmet face shield when riding any ENVO Drive Systems snow product.

CLOTHING

Be prepared, be warm and be comfortable when riding. Always check the weather forecast, including wind-chill, and dress accordingly.

WARNING

Avoid wearing loose clothing or long scarves, which can become entangled in moving parts and cause serious injury. Always wear an approved helmet and eye protection. Failure to do so could result in serious injury or death.

2.5. SAFETY GEAR

Riding in cold conditions and snowy terrain requires additional safety gear. Recommended items to take with you when riding include:

- Flashlight
- First Aid Kit
- Avalanche Beacon
- Shovel
- Food and Water
- Emergency Blanket

2.6. DRIVER AWARENESS

Always slow down when traveling near poles, posts, or other obstacles. Be especially alert if you are riding a SnowBike after dark. Look ahead, behind, and to both sides before crossing railroad tracks and roads. The SnowBike is very quiet so it is important to ensure the people and wildlife around you are aware of your presence when you pass by. Always be courteous to oncoming traffic and reduce your speed.

2.7. EXCESSIVE SPEED

Always observe all provincial and local laws and speed limits. Never modify your SnowBike to increase the speed or power. Modification may also create a safety hazard and lead to serious injury. Loss of control may occur at higher speeds.

2.8. OBSTACLES AND JUMPING

Do not jump your SnowBike over large drifts or similar terrain. The impact of landing your SnowBike after jumping may cause injury or death. Your SnowBike is not intended for this kind of use. Unplanned jumps of snowdrifts, snowplow ridges, culverts or indistinguishable objects can be dangerous. You can avoid these instances by wearing coloured lenses or face shields, and by operating at a lower speed. If you unintentionally jump off an obstacle or the trail unexpectedly drops away, lean back slightly and keep the ski up and straight ahead. Brace yourself for the impact and keep your knees bent.

2.9. UNSEEN OBSTRUCTIONS

There may be obstructions hidden beneath the snow. Traveling off established trails as well as in wooded areas requires a reduced speed and increased vigilance. Traveling too fast in any area can make even minor obstacles very hazardous. Stay on established trails to reduce your exposure to hazards. Always be on the lookout for hidden wires, fences, tree branches and other objects, especially in areas that may have been or is currently a farm.

2.10. HAND SIGNALING

Always signal when others are behind you when you intend to turn or stop. A left turn is indicated by extending your left arm straight out so it is parallel to the ground. For right turns, extend the left arm and raise the hand vertically forming a right angle at the elbow, or extend your right arm straight out so it is parallel to the ground. If you are stopping or slowing down extend your left or right arm and point your hand downward bending at the elbow to form a right angle.

2.11. TRAILS

Before riding on a trail always check to see if low-powered vehicles are permitted. Whenever possible, pull off the trail to prevent colliding with others. Become familiar with all signage used in the area where you are snowbiking.

2.12. RIDING AT NIGHT

Traveling at night requires extra caution. Check your headlight and taillight to ensure proper operation. Always ensure you can bring your SnowBike to a complete stop within the distance illuminated by the headlight. The amount of natural and artificial light at any given time can effect your ability to see or to be seen. Stay on established trails and never operate in unfamiliar territory. Always avoid rivers and lakes at night. Wires, fences, tree branches and other objects are difficult to see at night. Never ride your SnowBike at night alone. Always carry a flashlight and wear proper riding gear including reflective articles of clothing to ensure maximum visibility.

2.13. RIDING IN A GROUP

We always recommend riding with a partner or in a small group. When traveling in a group of SnowBikes, don't follow too closely. Leave enough distance between SnowBikes to provide ample stopping room and to provide protection from flying snow and debris. Allow even more distance when driving on slippery surfaces or when traveling in darkness or other low visibility conditions. Drive defensively to avoid accidents.

2.14. TERRAIN & WEATHER CONDITIONS

CAUTION

Driving in too little snow will result in excessive wear and damage to the track and ski.

2.14.1. DEEP SNOW

In deep snow, your vehicle may begin to sink down. If this occurs do not spin your track as this makes the vehicle sink deeper. Instead, dismount and move the vehicle onto new snow. Then tramp a clear path a few metres ahead of the vehicle. Never place foreign material beneath the track to improve traction. Always keep your hands away from the track. Personal injury will result if contact is made with the revolving track.

2.14.2. FROZEN WATER AND ICY SURFACES

Traveling on frozen lakes and rivers can be fatal. Never attempt to operate your SnowBike on a frozen body of water. When operating on unavoidable icy surfaces—excluding frozen bodies of water, drive slowly with caution. Allow yourself plenty of room for stopping and turning.

WARNING

Never attempt an abrupt change of direction when operating on slippery surfaces. Proceed slowly and use extra caution. Driving on ice or hard-packed snow reduces steering and braking control, which may result in loss of control and serious injury or death. Slow down and use extra caution when operating on slippery surfaces.

2.14.3. HARD PACKED SNOW

Like ice hard packed snow should be avoided when possible. The ski and track have limited traction on hard packed snow. Slow down and avoid rapid acceleration, turning or braking.

2.14.4. UPHILL

Climb hills with caution. If you become stuck and cannot proceed further, avoid spinning the track. Lean forward slightly when climbing to avoid tipping backward. Always slow down when you reach the crest of the hill. Avoid extremely steep inclines.

2.14.5. DOWNHILL

Downhill driving requires that you have full control of your vehicle at all times. On steeper hills, go slowly and keep your center of gravity low and both hands on the handlebar. If a higher than safe speed is reached, slow down by braking but apply the brake with frequent light pressure. Never jam the brake and lock the track.

2.14.6. SIDE HILL

When crossing a side hill or traversing up or downhill, certain procedures must be followed. All riders should lean towards the slope as required for stability. Be prepared to shift your weight quickly if needed. Side hills and steep slopes are not recommended.

⚠️ WARNING

Climbing a hill or crossing the face of a slope may result in loss of balance and SnowBike rollover, causing serious injury or death. Use caution and good judgment when operating on hilly terrain.

2.14.7. SLUSH

Slush should be avoided at all times. If you are unable to avoid watery and icy conditions dismount and walk your SnowBike to more suitable terrain.

2.14.8. FOG OR WHITEOUT CONDITIONS

Do not operate the SnowBike in fog or heavy snow. The SnowBike was created for recreational purposes and should not be used as a mode of transport for mandatory travel or during an emergency.

2.14.9. BRIGHT SUNSHINE

Bright sunny days can considerably reduce your vision due to the glare of the sun off the snow. Goggles with coloured lenses should always be worn under these conditions. Riders should reduce their speed and proceed with caution.

2.14.10. UNFAMILIAR TERRITORY







When you enter an area that is new to you, drive with extreme caution. Go slow enough to recognize potential hazards such as fences, rocks, sudden dips, tree branches, wires and other obstacles. Even when following existing tracks, be cautious. Travel at a slow speed so you can see what is around.

2.15. AVALANCHE HAZARD

When riding on mountainous terrain, you should be aware of the risk of avalanches. Avalanches vary in size and shapes and generally occur in steep terrain and on unstable snow. New snow, wildlife, people, wind and low-powered vehicles like the SnowBike can all trigger an avalanche. Avoid terrain where avalanche conditions are possible. When in unstable snow conditions, travel should be restricted to lower angle slopes. When in the mountains be aware of the conditions and dangers. Check local avalanche forecasts before heading out to ride and always follow the safety recommendations of local authorities. You should always carry a snow shovel, probe and avalanche beacon while riding on mountains. We recommend that all mountain riders take a local avalanche safety training course.

2.16. NORTH AMERICAN AVALANCHE DANGER SCALE

Avalanche danger is determined by the likelihood, size and distribution of avalanches.

Danger Level		Travel Advice	Likelihood of Avalanches	Avalanche Size and Distribution
5 Extreme		Avoid all avalanche terrain.	Natural and human-triggered avalanches certain.	Large to very large avalanches in many areas.
4 High		Very dangerous avalanche conditions. Travel in avalanche terrain not recommended.	Natural avalanches likely; human-triggered avalanches very likely.	Large avalanches in many areas; or very large avalanches in specific areas.
3 Considerable		Dangerous avalanche conditions. Careful snowpack evaluation, cautious route-finding and conservative decision-making essential.	Natural avalanches possible; human-triggered avalanches likely.	Small avalanches in many areas; or large avalanches in specific areas; or very large avalanches in isolated areas.
2 Moderate		Heightened avalanche conditions on specific terrain features. Evaluate snow and terrain carefully; identify features of concern.	Natural avalanches unlikely; human-triggered avalanches possible.	Small avalanches in specific areas; or large avalanches in isolated areas.
1 Low		Generally safe avalanche conditions. Watch for unstable snow on isolated terrain features.	Natural and human-triggered avalanches unlikely.	Small avalanches in isolated areas or extreme terrain.
<i>Safe backcountry travel requires training and experience. You control your own risk by choosing where, when and how you travel.</i>				
No Rating		Watch for signs of unstable snow such as recent avalanches, cracking in the snow, and audible collapsing. Avoid traveling on or under similar slopes.		

2.17. WINDCHILL CHART

The following information is provided to help you determine when temperatures become dangerous for riding.

Wind Speed $V_{10\text{ m}}$ (km/h)	Actual Air Temperature T_{air} (°C)											
	5	0	-5	-10	-15	-20	-25	-30	-35	-40	-45	-50
5	4	-2	-7	-13	-19	-24	-30	-36	-41	-47	-53	-58
10	3	-3	-9	-15	-21	-27	-33	-39	-45	-51	-57	-63
15	2	-4	-11	-17	-23	-29	-35	-41	-48	-54	-60	-66
20	1	-5	-12	-18	-24	-30	-37	-43	-49	-56	-62	-68
25	1	-6	-12	-19	-25	-32	-38	-44	-51	-57	-64	-70
30	0	-6	-13	-20	-26	-33	-39	-46	-52	-59	-65	-72
35	0	-7	-14	-20	-27	-33	-40	-47	-53	-60	-66	-73
40	-1	-7	-14	-21	-27	-34	-41	-48	-54	-61	-68	-74
45	-1	-8	-15	-21	-28	-35	-42	-48	-55	-62	-69	-75
50	-1	-8	-15	-22	-29	-35	-42	-49	-56	-63	-69	-76
55	-2	-8	-15	-22	-29	-36	-43	-50	-57	-63	-70	-77
60	-2	-9	-16	-23	-30	-36	-43	-50	-57	-64	-71	-78
65	-2	-9	-16	-23	-30	-37	-44	-51	-58	-65	-72	-79
70	-2	-9	-16	-23	-30	-37	-44	-51	-58	-65	-72	-80
75	-3	-10	-17	-24	-31	-38	-45	-52	-59	-66	-73	-80
80	-3	-10	-17	-24	-31	-38	-45	-52	-60	-67	-74	-81

where

T_{air} = Actual Air Temperature in °C

$V_{10\text{ m}}$ = Wind Speed at 10 metres in km/h (as reported in weather observations)

Notes:

1. For a given combination of temperature and wind speed, the wind chill index corresponds roughly to the temperature that one would feel in a very light wind. For example, a temperature of -25°C and a wind speed of 20 km/h give a wind chill index of -37. This means that, with a wind of 20 km/h and a temperature of -25°C, one would feel as if it were -37°C in a very light wind.
2. Wind chill does *not* affect objects and does *not* lower the actual temperature. It only describe how a human being would feel in the wind at the ambient temperature.
3. The wind chill index does *not* take into account the effect of sunshine. Bright sunshine may reduce the effect of wind chill (make it feel warmer) by 6 to 10 units.

Frostbite Guide
Low risk of frostbite for most people
Increasing risk of frostbite for most people within 30 minutes of exposure
High risk for most people in 5 to 10 minutes of exposure
High risk for most people in 2 to 5 minutes of exposure
High risk for most people in 2 minutes of exposure or less

3. BATTERY & CHARGER SAFETY

3.1. OVERVIEW

ENVO Drive Systems batteries are of the highest quality. They are equipped with Smart Chargers and a Smart BMS (battery management system) to ensure the battery will last as long as possible. You can expect your ENVO Drive Systems battery to last a minimum of 3 years, and up to 5-8 years, depending on extent of use.

WARNING

Failure to properly use, charge, and store your battery as instructed will void the warranty and could cause a hazardous situation. Before using your battery for the first time, read this section of the manual in its entirety. If you have any questions about your ENVO battery or its usage, please visit support.envo-drive.com or give us a call

WARNING

NEVER disassemble the battery, there is significant risk of shock and damage to the battery. Doing so will also void the warranty. DO NOT puncture or crush the battery, or expose to server vibrations and impacts.

3.2. FIRST CHARGE

- Batteries are not shipped with a full charge. You should charge your battery for at least 4-5 hours with a super external charger or for at least 10 hours with the internal charger.
- The ENVO Drive Systems battery is equipped with a 5 minute sleep function. If no activity is detected, the SnowBike will go into “static” mode to conserve battery power. Simply cycle the bike off then on again to reactivate the battery.
- The rated output capacity of the battery is measured at 77°F. Any variations in this temperature will alter the performance of the battery. Keep your battery away from high temperatures as heat will reduce overall battery life and run time.
- No “break in” period is necessary for our batteries, simply fully charge the battery before first use.

WARNING

Do not drop the battery. Damaged batteries can cause fire and may explode which can lead to damaged property, injury or even death.

3.3. CHARGING YOUR BATTERY

- Charge your battery indoors whenever possible. Charge your battery during the day in a room which has a smoke or fire detector. Do not charge in your bedroom
- During the charging process, place the battery on a non-flammable surface or leave in the main sleeve.
- Charge in a well-ventilated area. Keep away from flames and sparks
- Avoid any contact with water or other fluids while charging. If the battery, charger or any connections become wet, immediately unplug the charger and thoroughly dry all components
- Never use the internal charger after riding in the rain – wait at least 24 hours before using the internal charger

IMPORTANT NOTE:

As your battery ages, it will gradually lose capacity. With proper care and maintenance, your lithium ion battery will retain up to 70% of its capacity for about 500 full discharge/recharge cycles. As capacity diminishes, you will notice a gradual drop off in max range capability. When range falls to an unacceptable level, contact your local ENVO dealer to purchase a new battery.

3.4. BATTERY AND CHARGER CARE

- Your SnowBike Battery comes with a Smart Internal Charger that uses the best possible charging techniques to ensure longevity of the battery. The external charger will charge a fully depleted battery in 5-6 hours. The internal charger will charge it within 12-14 hours. The indicator light on the charger will be red/orange when the battery is charging and will turn green when fully charged.
- Avoid subjecting the battery to high temperatures, such as direct sunlight for prolonged periods of time. Recharge the battery before it becomes completely discharged. Completely discharging will reduce the numbers of recharging cycles during the battery's life and limit the capacity.

- Never store the battery in the discharged state. After extensive use, your battery's charge-holding capacity will decrease. If you find that your battery does not hold sufficient charge, you should contact ENVO Drive Systems to order a replacement.
- If the battery isn't used for an extended period of time, charge it fully and recharge it every 2 months. Store it in a cool, dry place.
- Your ENVO Electric SnowBike battery is engineered with precision for a long useful life. Do not use it to power other electrical devices. Improper use of the battery may shorten its useful life or cause fire or explosion. If you experience unusual sounds or odors coming from the charger or the battery, unplug the charger immediately and contact ENVO Drive Systems customer service.

3.5. BATTERY MAINTENANCE

- Improper use of the battery charger can cause a fire resulting in property damage, severe injury, or death. Please review the following instructions and guidelines carefully to ensure safe battery use and maintenance.
- If you are not going to use your battery for a while, fully charge the battery prior to turning it off. Be sure to turn on and charge your battery every 2 months to ensure it never completely loses its charge.
- The battery will get hot during charging, this is normal; however, if you smell or see any smoke, turn the battery and charger off and unplug anything attached to the battery. Call ENVO Drive Systems to obtain a diagnosis or a replacement.
- After a ride, fully recharge your battery as soon as it has cooled to room temperature. If battery is left in the discharged condition it will deteriorate much faster than a fully charged battery.
- Do not block the fan vent on the battery pack or external charger. This can cause overheating and fire.
- You should protect the battery from water. Never submerge your bike or battery in water, or spray the battery with water.
- DO NOT use this battery with any other vehicle or appliance. Use of this battery with any other product will void the warranty and may create hazardous conditions that could cause a fire, resulting in property damage, severe injury, or death.
- Never disassemble the battery or open the battery case. There is a significant risk of electric shock or damage to the battery. This will also void the warranty.

- Never short circuit the discharge terminals of the battery. A short circuit will damage the battery and could cause a fire which may result in property damage, severe injury, or death. When handling the battery, be aware of conductive materials that may short the battery terminals such as coins, nails etc.
- Never crush or puncture the battery. A punctured or crushed battery could catch fire causing a fire or explosion with could lead to property damage, severe injury, or death.
- Keep battery away from excessive heat (104°F or higher) or open flames. Avoid long-term exposure to direct rays from the sun.
- Protect the battery from materials that may contaminate the charge port or the output port, such as dirt and sand; the ports may be difficult or impossible to clean out.
- Never subject the battery to intense physical shock or severe vibrations.

3.6. BATTERY TRANSPORT

- Lithium-ion batteries are subject to many regulations and are often considered dangerous or hazardous materials by carriers. Be sure to check for relevant laws and ask the carrier for approval prior to shipping a Lithium-ion battery or transporting it by air

3.7. BATTERY DISPOSAL

- Be friendly to the environment. Recycle your old batteries at a local battery recycle centre
- Batteries should never be thrown in the garbage

⚠ WARNING

Disposing of Lithium Ion batteries incorrectly can allow moisture and oxygen to enter the battery and oxidize the lithium components, causing a heat reaction. This can lead to fires or explosions. Overheating, overcharging and shock from dropping or crushing can also cause heat reactions to occur. Batteries must always be recycled. Do NOT throw your battery in the garbage.

4. PRODUCT DESCRIPTION

4.1. COMPONENTS

IMPORTANT NOTE: Some of the illustrations and photos used in this manual are general representations. Your model may differ.



1	Snowboard	8	Controller Bag
2	Front Fork Connector	9	Rear Fork Connector
3	Headlight	10	Electric Motor with Sprocket
4	Throttle	11	Snow Track
5	Controller Display	12	Guide Rollers
6	Controller Keypad	13	Peddle Assist Sensor Disc
7	Battery	14	Front Fork Support Clamp

4.2. DIMENSIONAL OVERVIEW

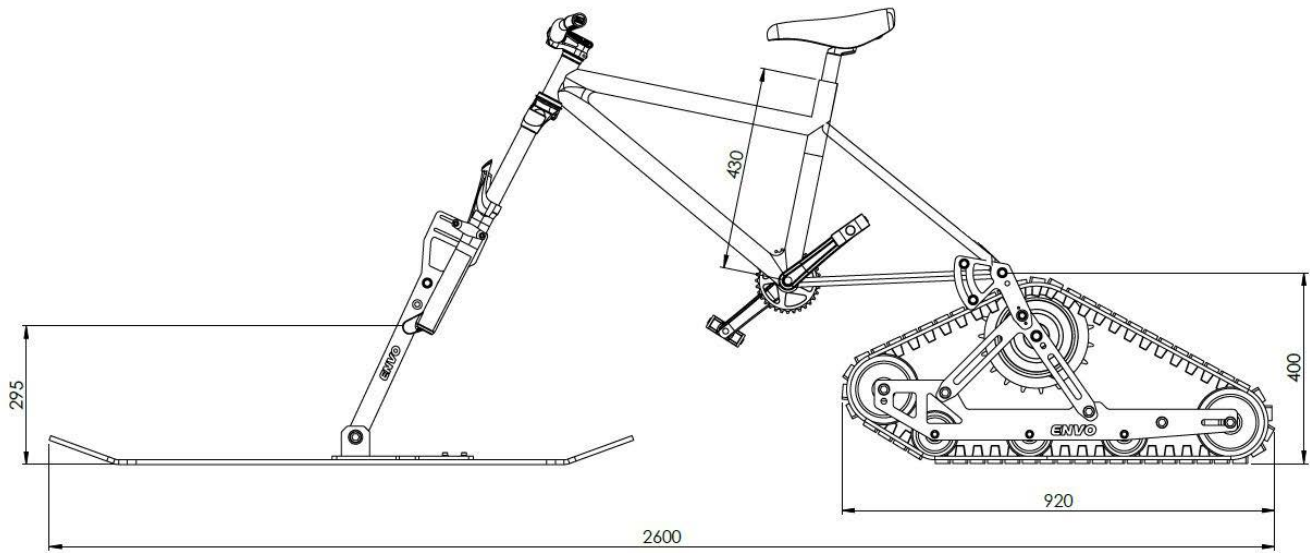

Side View

* All the dimensions are given in the above picture are for reference only. Dimensions will vary depending on the bike frame.

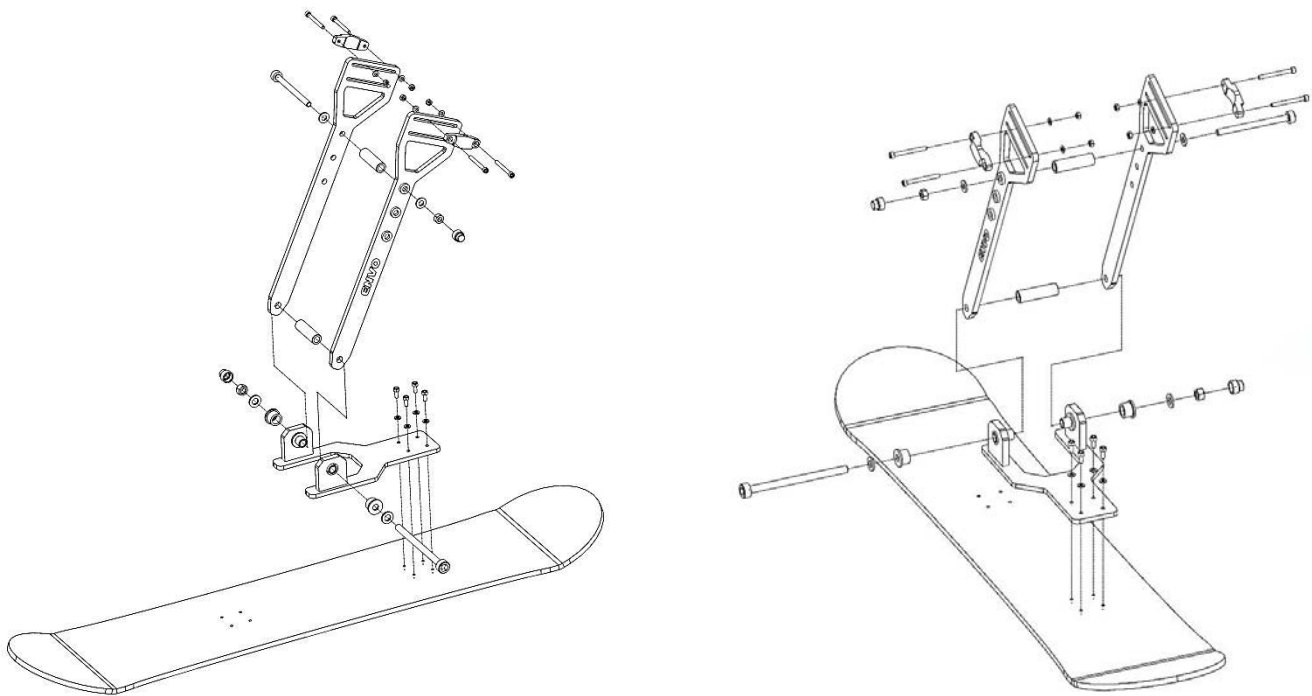

Front Fork Connector Assembly

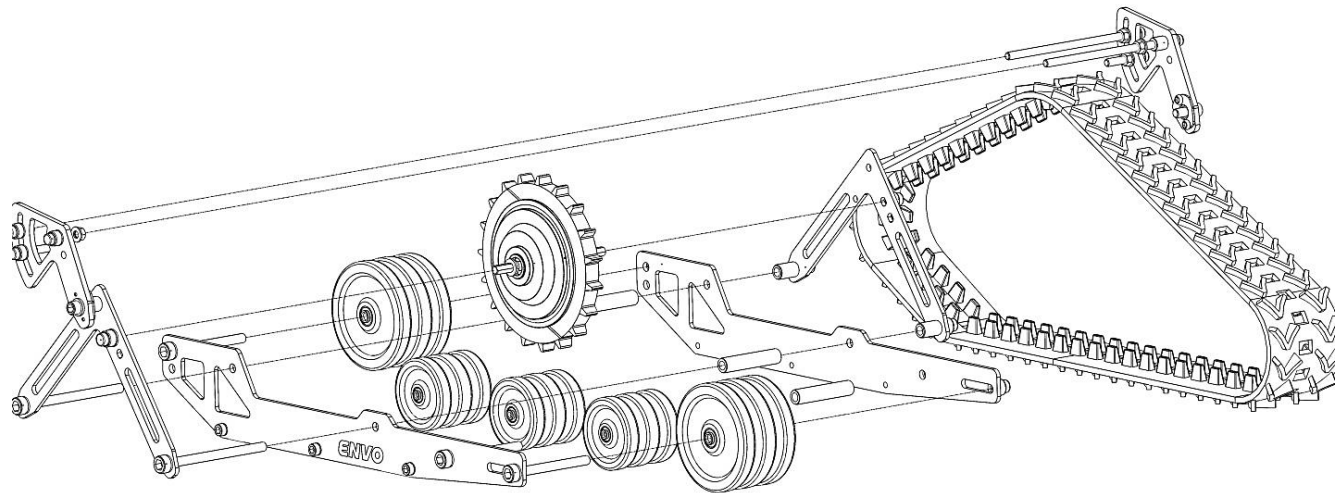
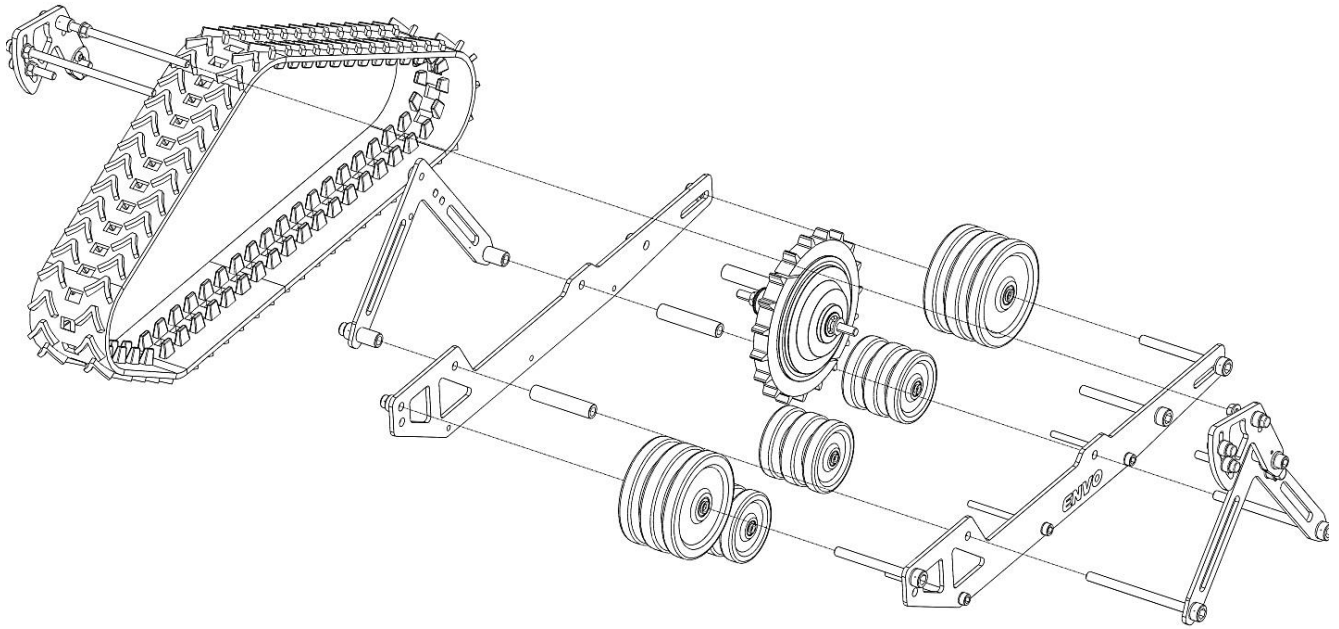

Rear Snow Track Assembly

5. ASSEMBLY INSTRUCTIONS

5.1. UNBOXING



1. Open box from top. Be careful of the metal pins used for packing.



2. Gently lay the box on its side and slide the SnowBike kit assembly out of the box. It's best to complete this process with two people, with one on either side.

5.2. REAR SNOW TRACK ASSEMBLY

1. Position the rear dropout of the bike frame between the rear snow track's connecting plates. Insert the M10 threaded round bar through the holes of the connecting plates and the rear dropout of the bike. Put an appropriately sized spacer between the bike frame and each connecting plate on either one or both sides of the bike frame according to the bike frame's geometry. Tighten two M10 Hex Nuts on the inside of the bike's rear fork and two M10 Hex Nuts on outside of the rear snow track's connecting plate.

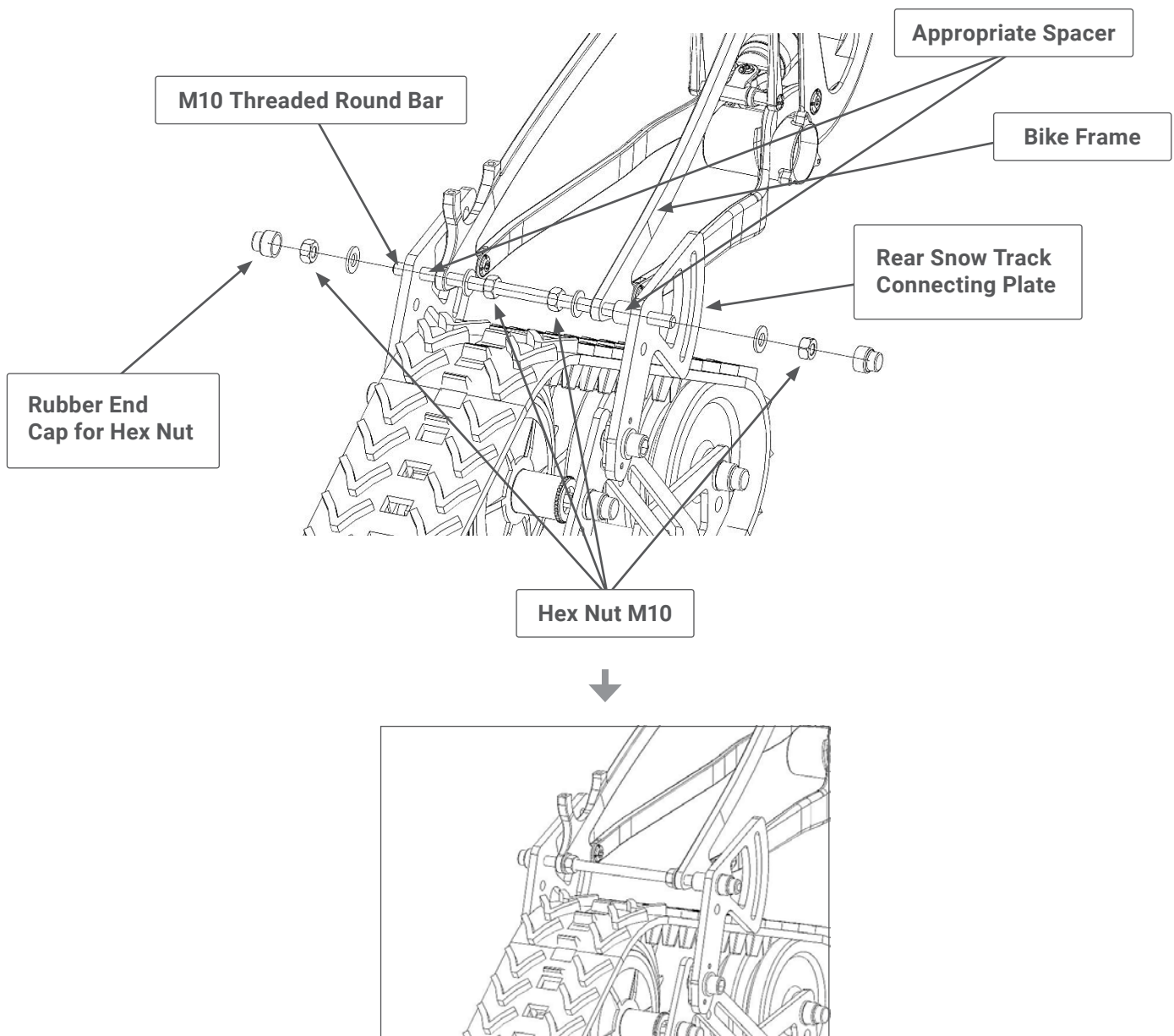

- Loosely tighten all the M10 nuts so the rear snow track's connecting plates have some movement that way the alignment of the rear snow track assembly and the bike frame can be properly adjusted.

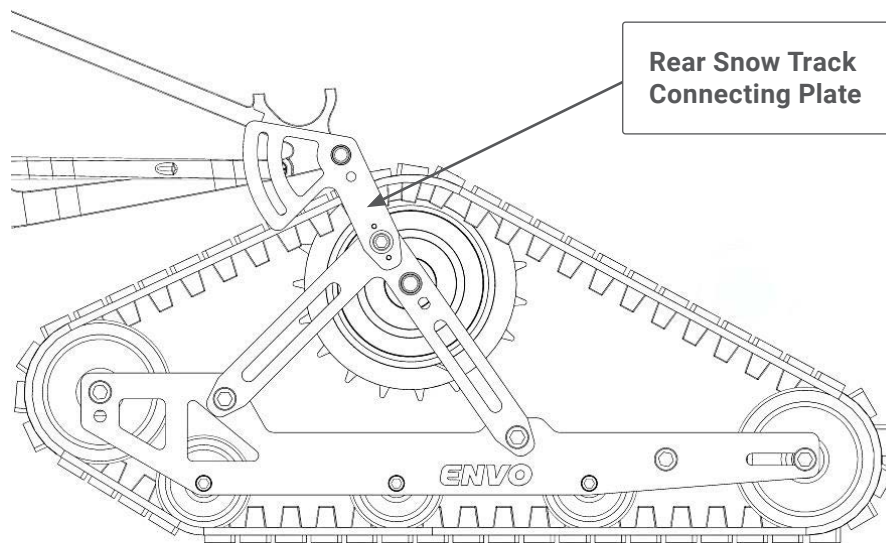

- Rotate the connecting plates of the rear snow track so that snow track assembly is aligned with the bike frame. Make sure the bike frame is centered within the snow track assembly as shown in below figure.

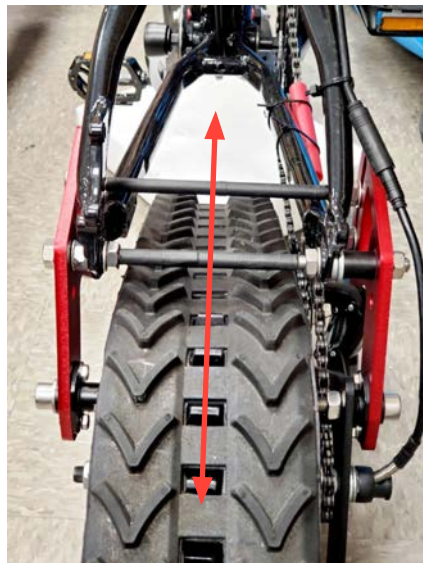

- After aligning, tighten all four M10 Hex Nuts so they are secure. If the bike frame is not fitting between rear snow track's connecting plates, then more spacers may be required.

- To adjust, remove Allen Bolt M12X40mm and place the appropriate spacer on one side or both sides, between the connecting plate and the welded bush of the motor arm plate.

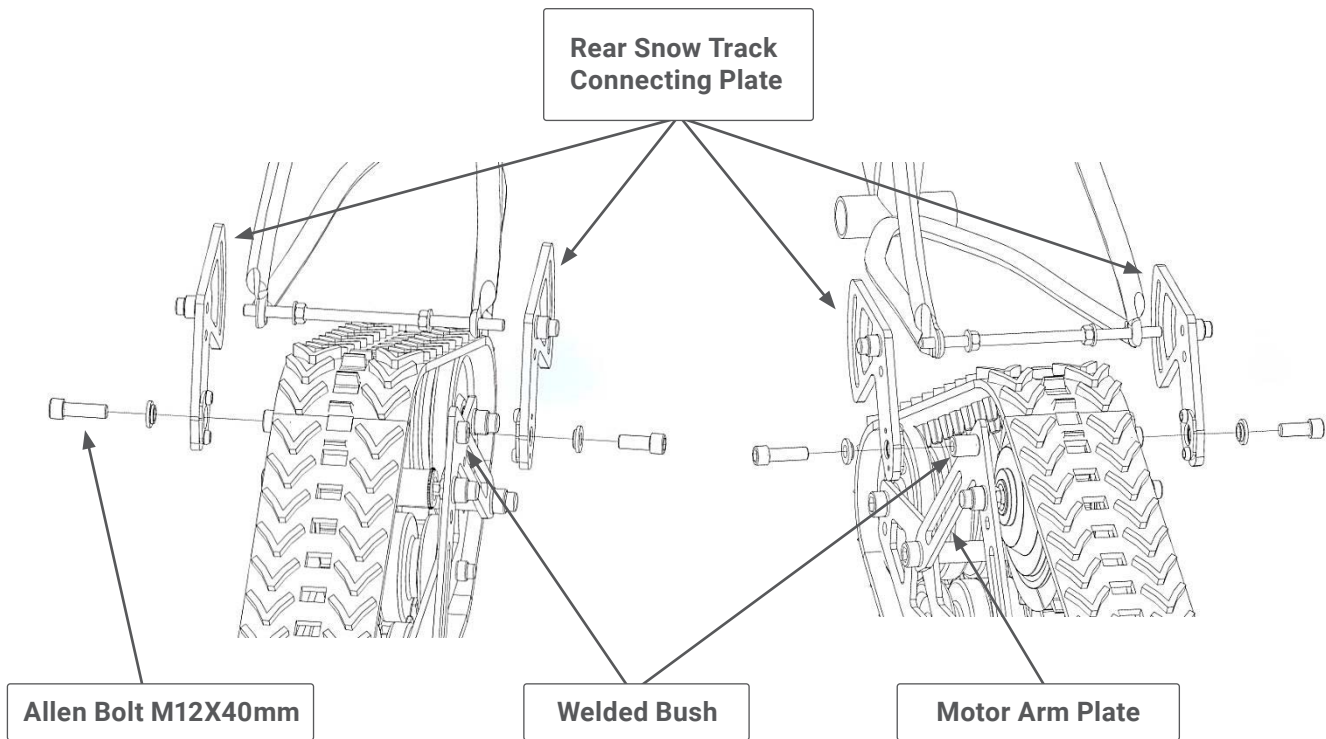

* Make sure the snow track assembly align with bike frame and should be centered between bike frame.

4. After aligning, insert another M10 threaded round bar that can pass through the curved slot of the connecting plate that rests on the top of the bike frame. Tighten all the nuts from the outside and the inside face of the plate.

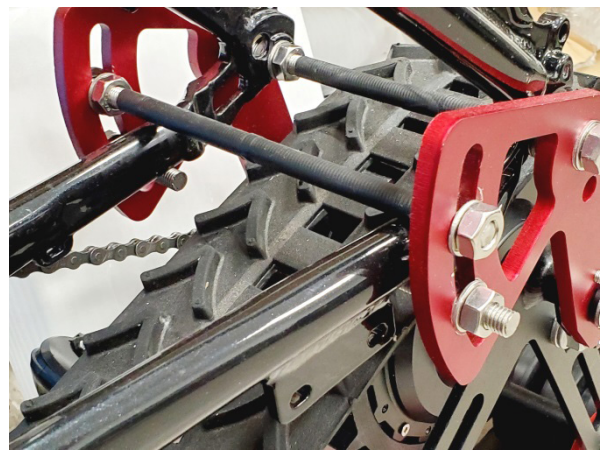
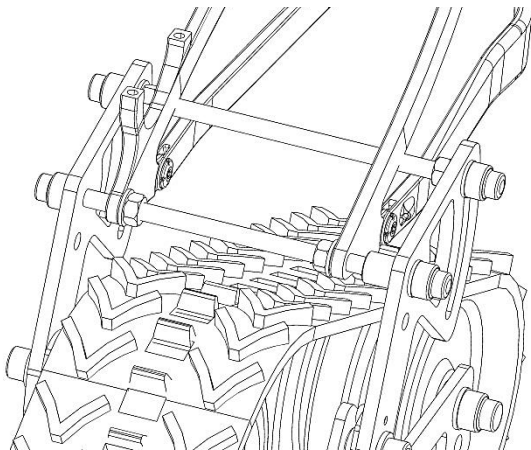
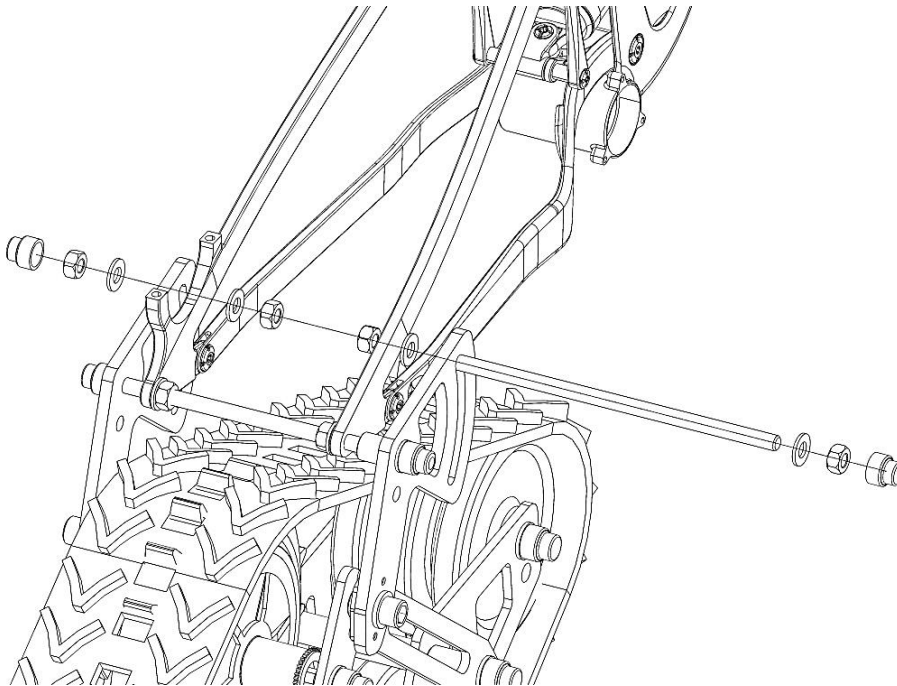

- Make sure the longer M10 threaded round bar is touching to the bike frame at all times

5. Insert smaller M10 threaded round bars that can pass through the curved slot of the connecting plate and rest on the bottom of the bike frame on both sides.

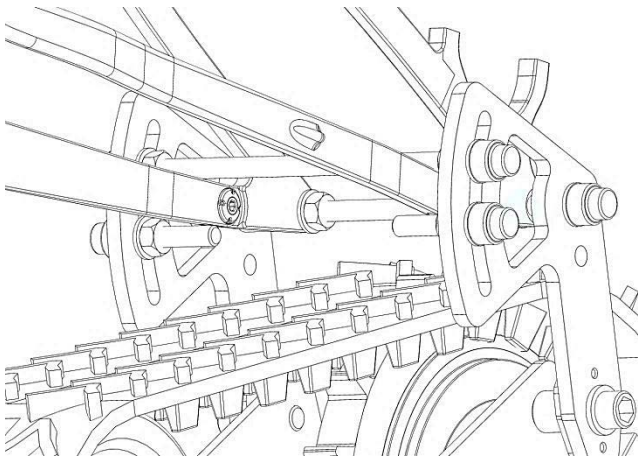
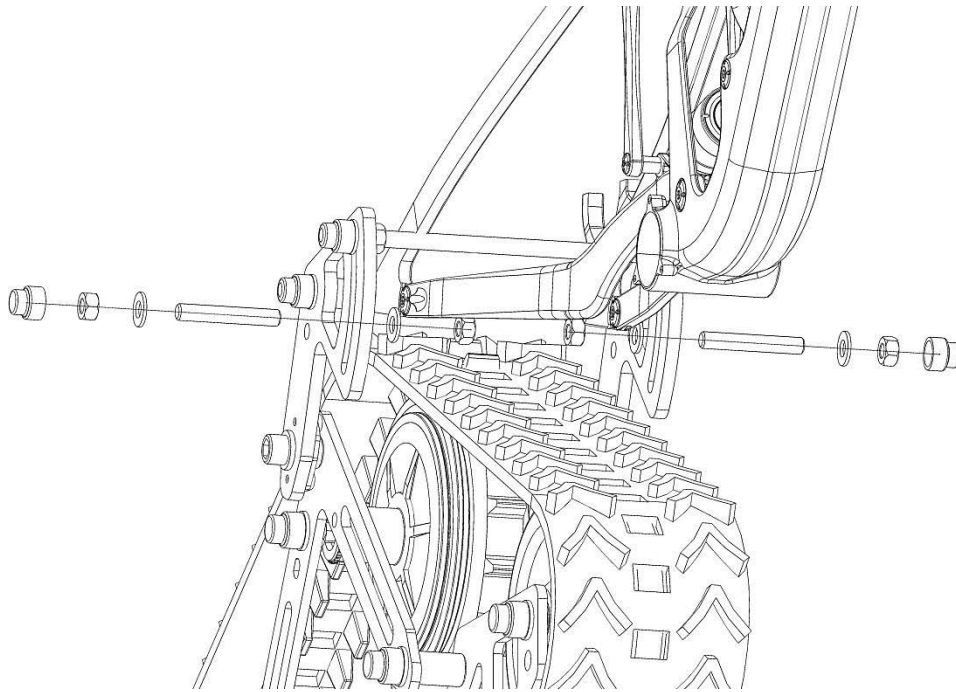

- Make sure the smaller M10 threaded round bars are touching to the bike frame all the times but does not touch to the snow track.

6. After completing the whole installation, check the snow track tightness. The snow track should not be loose. If the snow track is loose then attach the snow track tensioner to the assembly on the both sides as shown in the figure below.

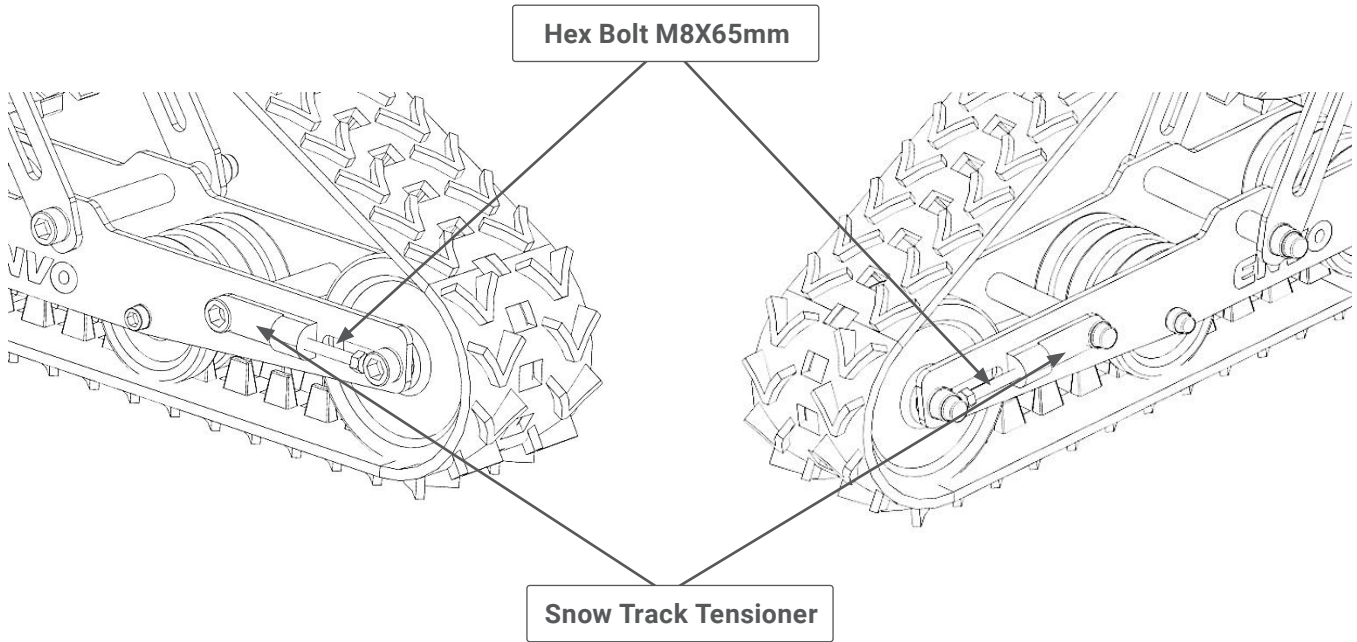

7. Tighten the snow track by rotating the Hex Bolt M8X65mm accordingly with the help of spanner.

5.3. FRONT FORK CONNECTOR ASSEMBLY:

1. Attach the snowboard to the front fork connector. Insert the M6 Washer followed by the M6x15mm Allen Bolt to fix the snowboard to the front fork connector part. A size 5 Allen Key is required to tighten the M6X15mm Allen Bolt.

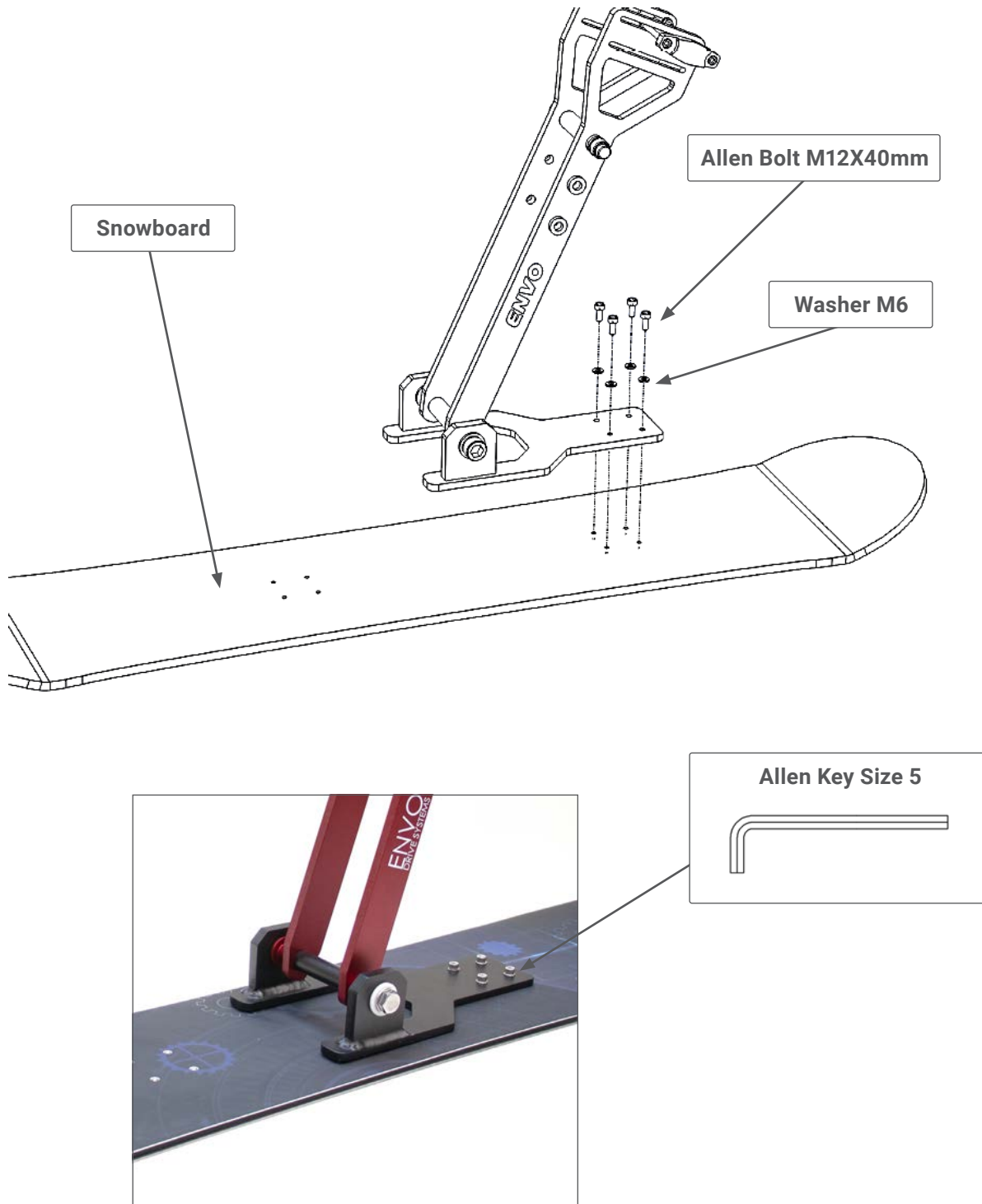

2. Remove the front wheel of the bike and fix the completed front fork connector to the bike's front fork. The SnowBike conversion kit is suitable for the bike fork size from 100mm to 140mm.

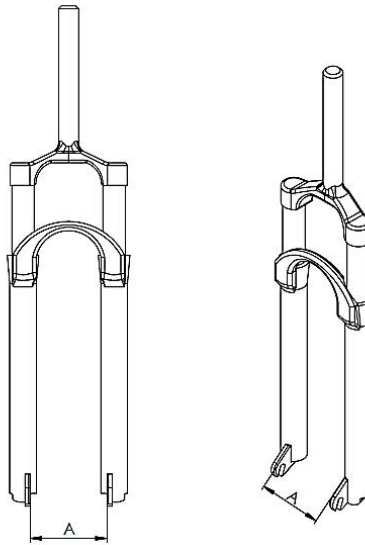

- If the dimension between the fork(A) from the above figure is standard (approx. 100mm or 135mm) then follow instruction (a). If the dimension (A) is not standard (between 100 mm and 140mm) than follow instruction (b).
- a. Insert the M10 Allen Bolt that can pass through the front fork of the bike and any hole out of three in the front fork connector based on the height adjustment.

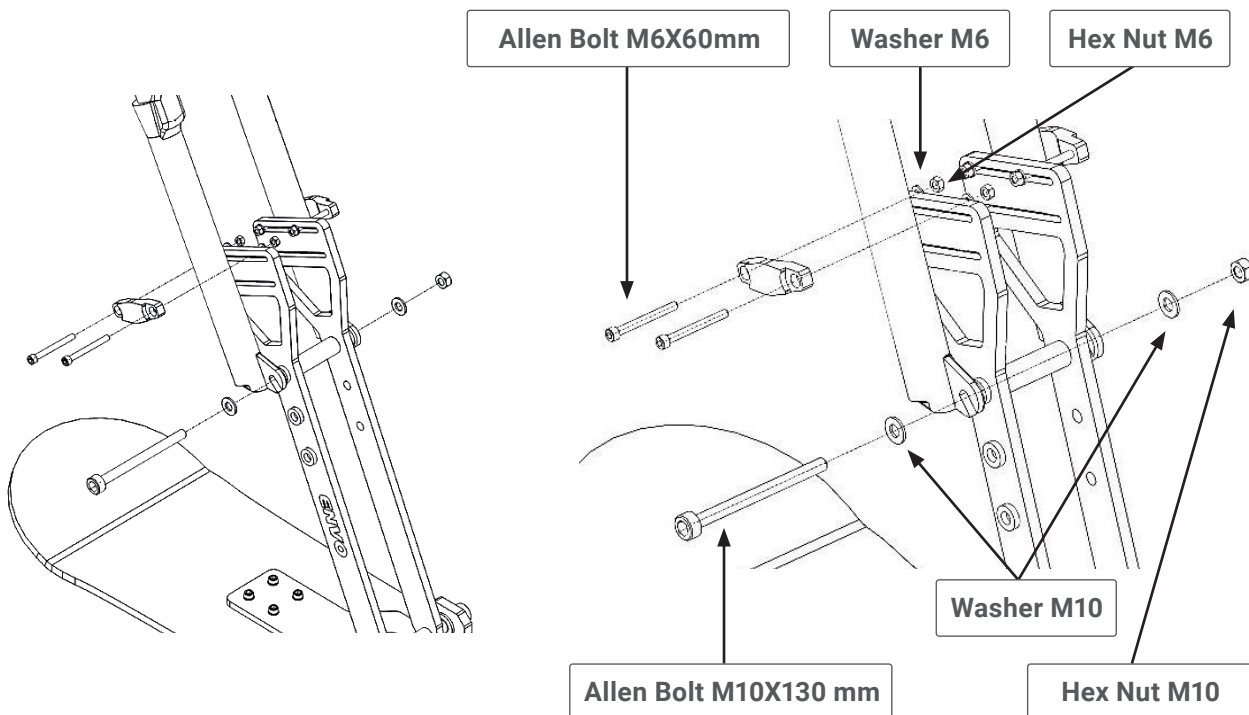

- Align the front fork connector assembly with the front fork of the bike and then fix the clamp.

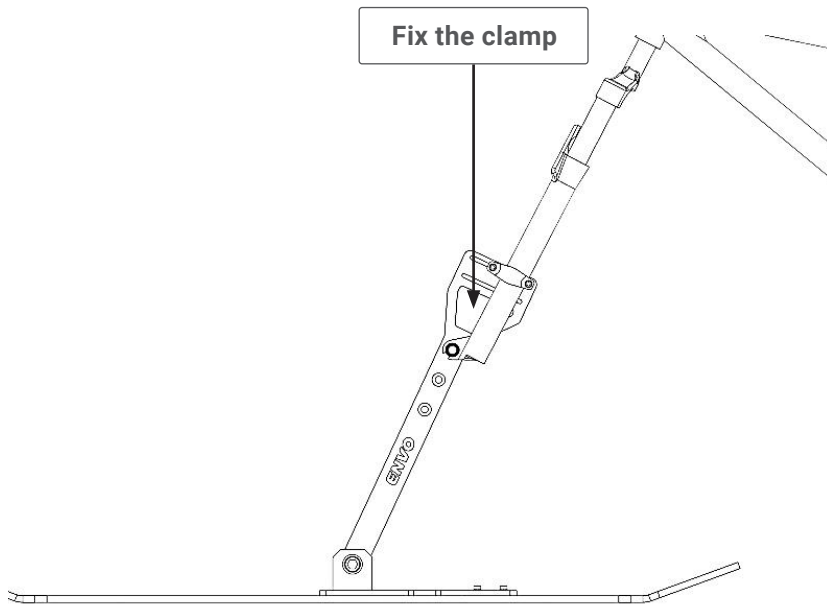

- b. If the dimension between the front fork (A) is not standard but is between 100mm and 140mm then the installation procedure is same as instruction (a). If there is a gap between the connector and the front fork add washers as shown in the figure below.

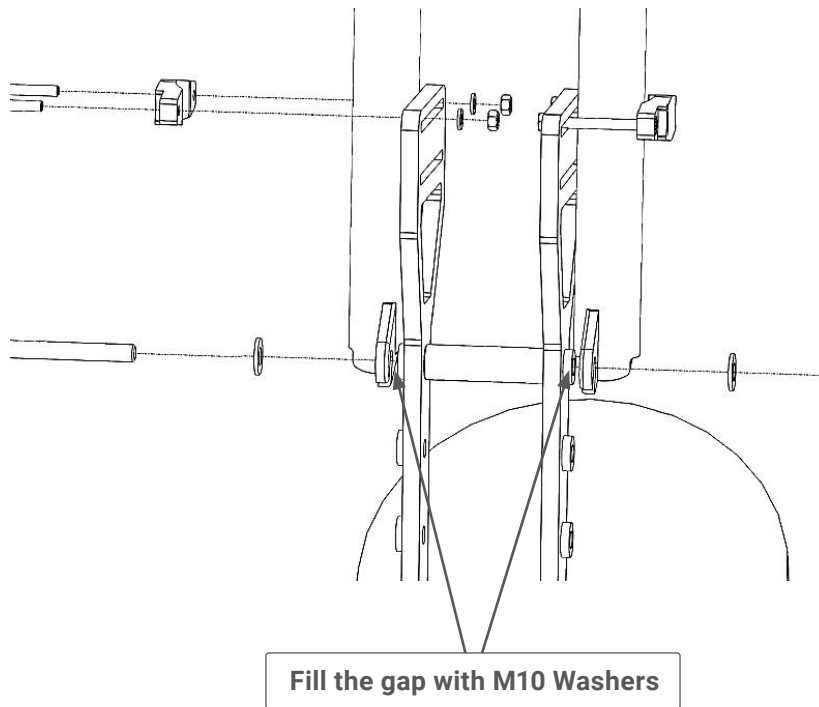

- If the front fork dimension (A) is more than 100mm then use a M10 Threaded Bar instead of a M10x130mm Allen Bolt. If this is the case you will need to tighten the Hex Nut from both sides.

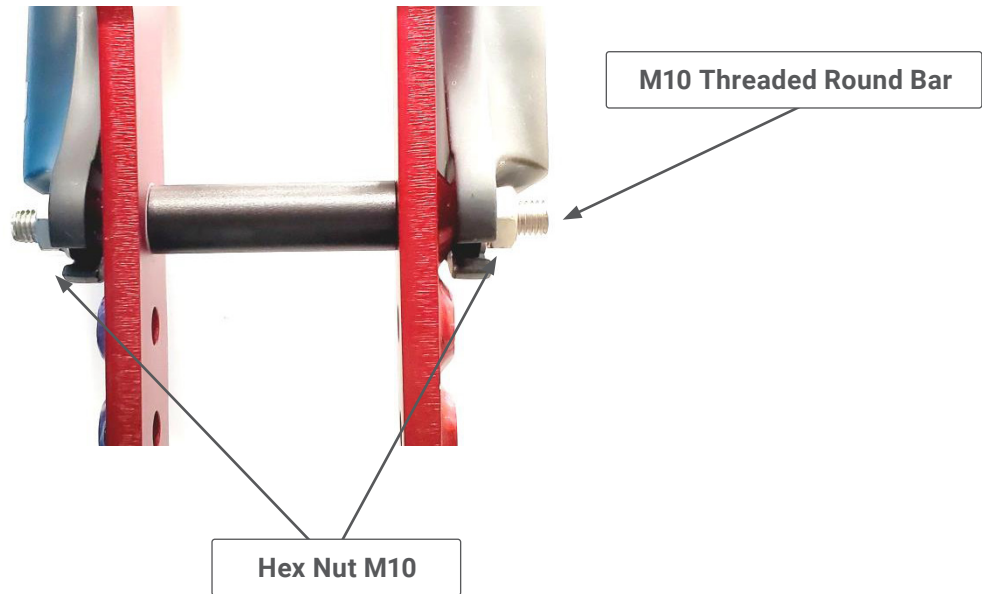

- After tightening both M10 Hex Nuts, cover them with rubber end caps as shown below.

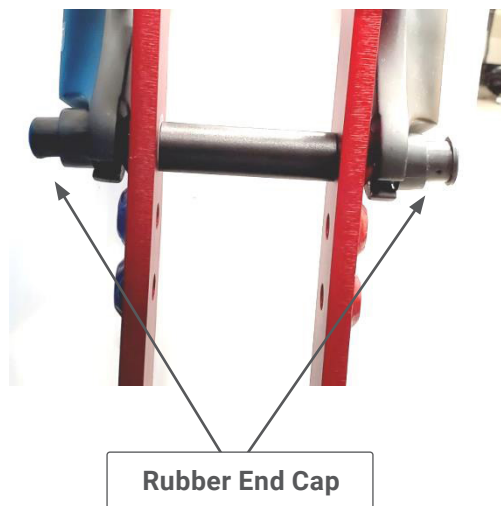

* For non-standard forks, Front Fork Connector assembly will be slightly different than regular assembly.

5.4. LCD INSTALLATION

METER DIMENSION

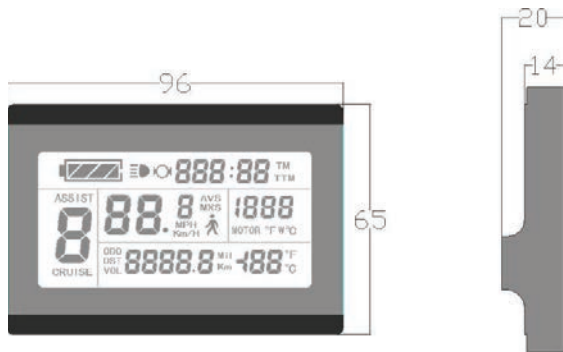

Meter Dimension

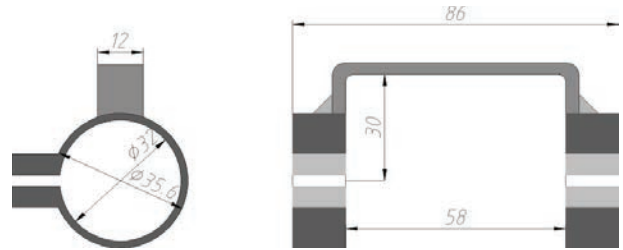

Dual Bracket Mounting Dimension

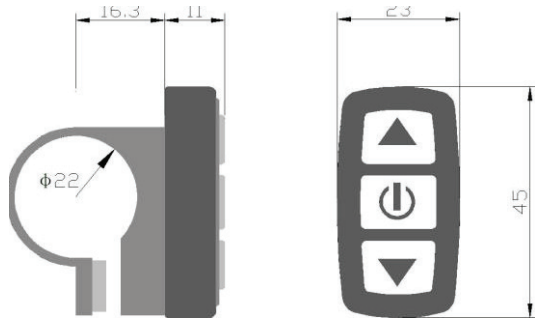

Button Box Dimension

PC material is mainly used for KT-LCD3 meter and button box housing, and the housing color is dark gray or white.

5.4.1. WIRING SCHEMATIC

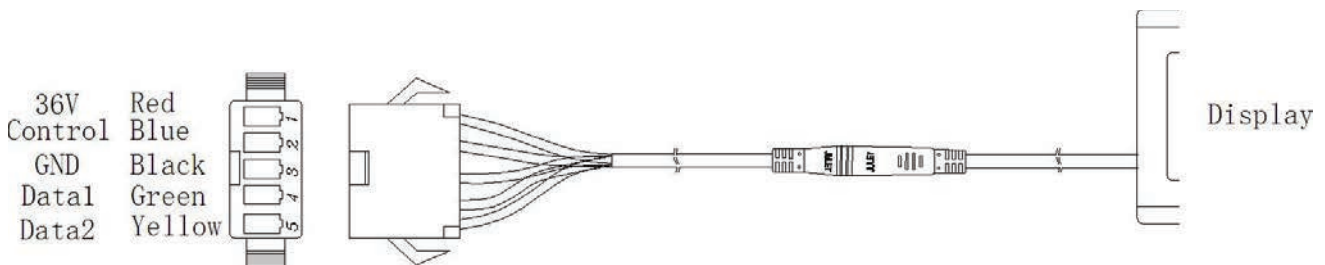

5.4.2. INSTALLATION

The meter body and button box are mounted on the handlebars of the electric vehicle, adjusting perspective. In the case that the vehicle is power off, the meter connectors are in plug connection to corresponding controller connectors. Turn on the power, electric vehicle and meter will be under normal operation, the meter installation is finished. The protection film on meter display panel should be torn.

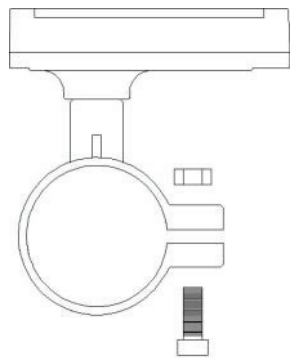

Lateral View

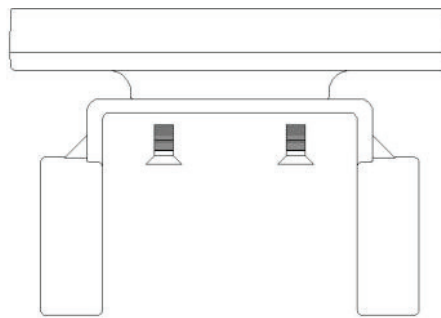

Meter and Dual Bracket View

the encircled rubber fielded panel is optional $\phi 22.2$ or $\phi 25.4$

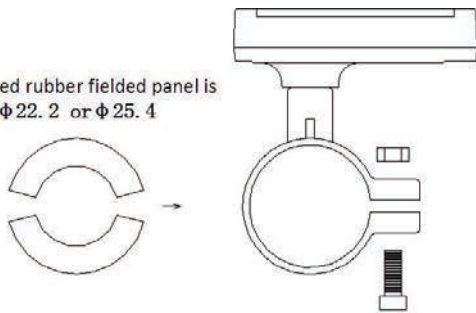

Lateral View

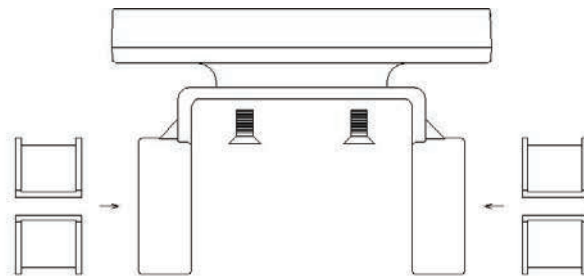

the encircled rubber fielded panel





the encircled rubber fielded panel

Meter and Dual Bracket View

6. OPERATING YOUR PRODUCT

6.1. LCD CONTROLLER FUNCTION OVERVIEW

KT-LCD3 meter provide you with a variety of functions such as vehicle controls and vehicle status digitized displays to meet the trip demands.

- Trip time display with displays of a single trip time (TM) and total trip time (TTM)
- Trip speed display with displays of real-time speed (Km/H or MPH) and a single maximum speed (MXS) and a single average speed (AVS)
- Trip distance display (with displays of a single trip distance (DST) and total trip distance (ODO))
- Power assistant ratio (or handlebar) gear (**ASSIST**) switch
- 6Km/H power assistant push () function
- Cruise function (**CRUISE**)
- Battery capacity indicator ()
- Real-time battery voltage (**VOL**) display
- Motor power and temperature (**MOTOR**) display
- Brake display ()
- Turn on backlighting and lights ()
- Environment temperature (°C or °F) display
- Data clearing
- Fault code display
- User parameter settings

6.2. DISPLAY CONTENT

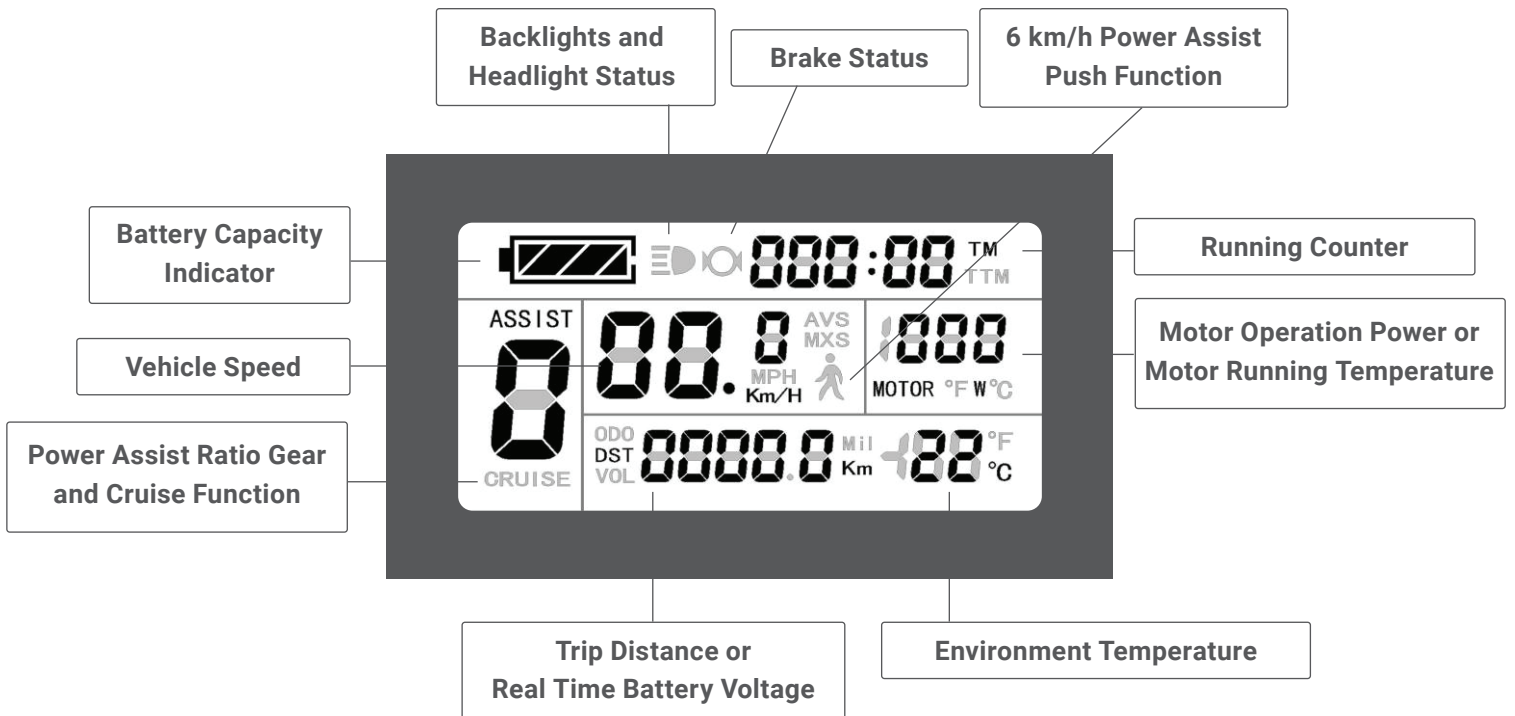

6.3. BUTTON DEFINITION

KT-LCD3 meter adopts the structural form with part design between the main part and operating buttons.

There are three keys on the operating panel of button box, which are icons of:



 button (alt text UP)
  button (alt text SW)
  button (alt text DOWN)



Button Box and Operating Panel

6.4. NORMAL OPERATION

6.4.1. ON/OFF

Hold  button (SW) long, the meter is powered on and into normal operation, and it provides the controller with power supply. Under normal operating status, hold  button (SW) long, the meter is powered off, meanwhile to shutdown the power supply of controllers. **When the vehicle is stopped and without any button operation on the meter for five minutes, the meter will automatically shut down, and the power supply of the electric vehicle will be powered off.** In power off mode, the power consumption of the meter and controller is zero.

6.4.2. DISPLAY 1

The meter is startup to enter Display 1:



Display 1

The Display 1 indicates battery capacity symbol, single trip time (TM), power assist level (ASSIST), real-time trip speed, single trip distance (DST), motor operation power (Motor, W), environment temperature, headlight and brake status symbols. It also shows cruise control symbol and power assist symbol if the bike is in those respective modes.

6.4.3. DISPLAY 2

In Display 1, hold  button (SW) shortly to enter Display 2:



Display 2

The Display 2 indicates total trip time (TTM), total trip distance (ODO), single average speed (AVS), and motor operating temperature.

6.4.4. DISPLAY 3

In Display 2, hold  button (SW) shortly to enter Display 3:



Display 3

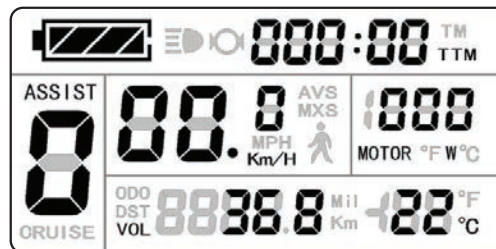

The Display 3 indicates maximum speed (**MSX**), and real time voltage (**VOL**).

In the riding mode after 5 seconds, single maximum speed will automatically return to real-time trip speed (Km/H) as shown in the icon.



In each display interface, if you hold  button (SW) long, the meter will be powered-off together with that of the controller.

6.4.5. PAS RATIO (OR HANDLEBAR) GEAR SWITCH

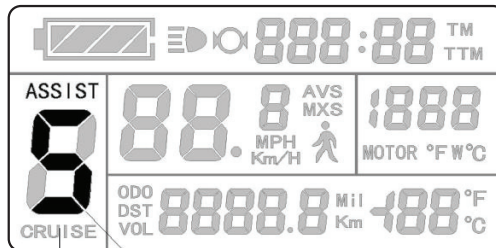

Under normal operation, hold  button (**UP**) or  button (**DOWN**) to switch the power assist ratio (or handlebar) gear (**ASSIST**), changing motor output power. Switching range is 1-5 gear (this can also be configured according to the customer requirements), gear 1 is for the lowest power, and gear 5 is for the highest power.



PAS Ratio or Handlebar Gear Switch

At every startup, the meter will automatically restore gear (this can also be configured as required by users) when it was at last shut down. When the power assist ratio is gear 0 zero, there's no power assist function.

6.4.6. POWER ASSISTANT PUSH FUNCTION

Users can use 6Km/H power assist function when pushing vehicles. Hold , the meter assist function logo () flashes, the vehicle drives at the speed of no more than 6Km/h. Release , the assist function will be revoked.

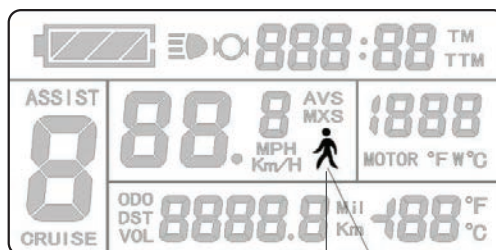



6 km/h Power Assistant Push Function

6.4.7. CRUISE FUNCTION

When C7 parameter setting is 1 (see C parameter setting), the meter turns on cruise function, hold  button (**DOWN**) long to enter the cruise status when the vehicle speed is more than 7 km/h, and the cruise function logo (**CRUISE**) lights. Brake or hold any button to revoke cruise function.

6.4.8. STARTUP BACKLIGHTS AND HEADLIGHTS

Hold  button (**UP**) long, the meter turns on the backlights as well as the vehicle headlights (the Controller should have headlights driving and output functions), meter backlighting and vehicle lights power logo () light, hold  button (**UP**) long again to turn off backlights and vehicle headlights.

6.4.9. BATTERY CAPACITY INDICATOR

The meter can automatically identify 24V, 36V, 48V battery capacities when it is supporting use with the specified controller. When the battery capacity is over 70%, the four power displays of the meter are lit, when the battery capacities drop, the four power displays are off in order, when the power capacity is less than 15%, the four power displays are totally turned off.

When the controller is power off due to voltage shortage, the power display frame flashes, indicating the vehicle has been in voltage shortage and waiting for shutdown currently.

6.4.10. MOTOR OPERATING POWER AND TEMPERATURE



Under the riding status of vehicle, the real time running and output power can be known via the meter displays.

The operating temperature of the motor shows there should be a temperature sensor installed in the Inner motor to output the temperature for signal detection simultaneously.

6.4.11. ENVIRONMENT TEMPERATURE

After startup, the environment temperature for using meter will be displayed in environment temperature display column. The temperature display value may be in deviation shortly after boot-up, and the display value will be gradually approaching the environment temperature within 10 minutes after boot-up.

6.4.12. SINGLE DATA CLEARING

5 seconds after the meter is powered on, at Display 1, hold both the  button (**UP**) and the  button (**DOWN**) simultaneously for about 2 seconds, the single trip time (**TM**) and single trip distance (**DST**) flicker, then hold  button (**SW**) shortly, the record contents of both will be cleared.

Under the status of data flashing, if there were no operations on the data within 5 seconds, the meter will automatically return to display1 after 5 seconds, and the original record content will be saved.

6.5.ERROR CODES

6.5.1. ERROR CODE DISPLAY

When the electronic control system of the electric vehicle fails, and the meter will automatically display (flicker) fault code. You can't exit the fault code display only the fault is removed.

ERROR CODE DEFINITION TABLE





ERROR CODE	DEFINITION
01 info	Throttle abnormality
02 info	Motor hall signal abnormality
03 info	Torque sensor signal abnormality
04 info	Battery does not charge up with standard charger
05 info	Axis speed sensor abnormality (only applied to torque sensor)
06 info	Motor or controller has short circuit abnormality

6.5.2. MOTOR OPERATING TEMPERATURE ALARM

Under any interface, when the motor operating temperature exceeds the warning value, the motor operating temperature display flashes to alarm, meanwhile, the controller will offer the appropriate protection to motor.

6.6. GENERAL PROJECT SETTING



6.6.1. MAXIMUM TRIP SPEED

Under power off status, hold  button (SW), until the meter is turned on. Within 5 seconds after boot-up, hold  button (UP) and  button (DOWN) simultaneously for about 2 seconds, the first is to enter the maximum riding speed setting interface, then the speed display column flashes. Hold  button (UP) shortly or  button (DOWN) in order to set the maximum riding speed value. The default maximum riding speed value was 25km/h. When the speed of the electric vehicle exceeds the set value, the motor will be stopped driving.

Under the setting maximum riding speed interface, if there's no button operation on the meter for more than 1 minute, and then the meter will automatically return to Display 1, and the original set values will be saved.

After finishing the maximum riding speed setting, hold  button (SW) shortly to save the current set values and enter into the next setting.



6.6.2. METRIC AND IMPERIAL UNITS

Enter into the metric/imperial units setting interface, and then the speed and mileage unit flash. Hold  button (UP) or  button (DOWN) shortly to make sync selection of three metric/imperial units as speed, mileage, and the environment temperature.

UNITS DEFINITION TABLE OF METRIC/IMPERIAL UNITS

DISPLAY	METRIC	IMPERIAL
Riding speed	km/h	mph
Total distance	km	mi
Environment temperature	°C	°F

Under the metric/imperial units setting interface, if there's no button operation on the meter for more than 1 minute, and then the meter will automatically return to Display 1, and the original set units will be saved.



After finishing the metric/imperial units setting, hold  button shortly (SW) to save the current set values, and then speed and mileage units stop flashing. Hold  button (SW) shortly again, and the meter will enter into the maximum riding speed interface again, or hold  button (SW) long for about 2 seconds to exit the general project setting environment and return to Display 1.

6.6.3. EXIT GENERAL PROJECT SETTING

Among the three general project settings, after each setting is completed, if hold  button (SW) long for about 2 seconds, all can exit the setting environment and return to Display 1, meanwhile, the current set parameters are saved.

Under each setting interface, if there's no button operation on the meter for more than 1 minute, and then the meter will automatically return to Display 1, and the original set parameters will be saved.

6.7. P PARAMETER SETTING

After finishing metric/imperial unit settings, the speed and mileage units stop flashing. Within one minute after stopping flashing, hold  button (UP) and  button (DOWN) simultaneously for about 2 seconds to enter P parameter setting environment.

6.7.1. P PARAMETER DEFAULT VALUES

NUMBER	PARAMETER NAME	DEFAULT VALUE
P1	Motor Characteristic Parameter Setting Mode	87
P3	Power Assist Control Mode	1
P4	Handlebar Startup Mode	0
P5	Power Monitoring Mode	12



After finishing each P parameter setting, hold  button (SW) shortly to save the current set values and enter next P parameter setting interface.

6.7.2. EXIT P PARAMETER SETTING

Among the five P parameter settings, when each parameter setting is completed, if held the  button (SW) long for about 2 seconds, all can exit the setting environment and return to Display 1, meanwhile, the current set parameters would be saved.

Under each parameter setting interface, if there's no button operation on the meter for more than 1 minute, and then the meter will automatically return to Display 1, and the original set parameters will be saved.

6.8. C PARAMETER SETTING

After finishing P5 parameter setting, P5 parameter column stops flashing. Within 1 minute after stopping flashing, hold  button (**UP**) and  button (**DOWN**) for about 2 seconds to enter C parameter setting environment.

6.8.1. C PARAMETER DEFAULT VALUES

NUMBER	PARAMETER NAME	DEFAULT VALUE
C1	Power assist sensor and parameter select mode	7
C2	Motor phase classification coding mode	0
C3	Power assist ratio gear initialization mode	2
C4	Handlebar function setting mode	0
C5	Controller maximum current adjustment mode	0
C6	Backlight brightness adjustment mode	2
C7	Cruise function setting mode	0
C8	Motor operating temperature display mode	1
C9	Startup password setting mode	0
C10	Restore default settings	n
C11	Meter attribute settings	0
C12	Controller minimum voltage settings	4
C13	Abs breaks and anti charge control settings	4
C14	Power assist tuning settings	3

After finishing each C parameter setting, hold  button (**SW**) shortly to save the current set values and enter next P parameter setting interface.

6.8.2. EXIT C PARAMETER SETTING

Among the twelve C parameter settings, when each parameter setting is completed, if held  button (**SW**) long for about 2 seconds, all can exit the setting environment and return to Display 1, meanwhile, the current set parameters would be saved.

Under each parameter setting interface, if there's no button operation on the meter for more than 1 minute, and then the meter will automatically return to Display 1, and the original set parameters will be saved.

IMPORTANT NOTE:

After entering the user setting environment, if there's no button operation on the data for more than 1 minute, the meter will automatically return to display1, and the new set parameters won't be saved. The factory parameter set value and the default value of the meter can be set according to user requirements, the meter parameter can be restored by using "C10 automatically restore factory setting mode" approach when adjusting it.

6.9. HAND THROTTLE CONTROL

- The ENVO SnowBike Kit is equipped with a thumb throttle, which is located on the right side of the handlebar
- Like on a motorcycle, a bike throttle is designed to let the user apply 0-100% of the motor's power at will. The throttle can act independently or in tandem with or without the Pedal Assist System
- When you want to slow down, you simply release the throttle and let it return to its resting position and simultaneously apply the brakes

6.10. OPERATING RANGE

Expect a range of about 20 km with medium motor use, flat ground, light wind and for an average weight person.

The range on SnowBike can vary greatly and are heavily dependent on these factors:

- Battery age
- Rider and luggage weight
- Snow conditions (soft or hardpacked)
- Wind speed and direction
- SnowBike usage (heavy acceleration and high speeds will drain the battery faster)
- Road slopes or hills
- Pedaling power
- Weather and temperature

6.11. MAXIMIZE YOUR RANGE

- Fully charge your battery before each ride
- Ride in Pedal Assist mode as much as you feel comfortable. The more you assist the motor, the longer it will assist you
- Service your bike periodically, ensuring bearings run smoothly, and the brakes do not rub the rotors or rims
- Minimize the weight you carry
- Lubricate the chain every few rides, more so if riding in the rain
- Clean the drivetrain as often as you can and thoroughly clean it at least once a month
- Avoid sudden starts and stops
- Minimize use of throttle

7. MAINTENANCE & REPAIR

7.1. MAINTAINING PARTS

- Once installed, your Electric SnowBike Kit like any normal ebike, requires regular maintenance. The drivetrain needs cleaning and lubrication, the brake pads need to be changed periodically, and levers need to be bled if hydraulic or cables are changed
- In this manual we provide important basic guidelines on how to maintain and inspect your installed SnowBike Kit. We cannot teach you everything you need to know to properly inspect and service your SnowBike. That is why we repeatedly encourage only mechanically inclined users purchase this product
- Ensure your snowboard is waxed and regularly inspected for cracks and other damage
- Your installed SnowBike Kit should be periodically cleaned

7.2. IN CASE OF ACCIDENT

WARNING

If you have an accident, drop your SnowBike or your SnowBike falls over, your SnowBike is unsafe to ride until you follow the instructions included in this section. Failure to follow these instructions could lead to component or bike operation failure which could lead to serious injury or death.

1. Remove the battery before performing any additional service, inspection, or maintenance on your SnowBike. Failure to remove the battery could lead to the SnowBike turning on unexpectedly, causing serious damage or injury
2. Read, understand and comply with the drive system user manual. Do not disassemble or attempt to service components unless you have been advised how to do so, explicitly in writing, by the ENVO Drive Systems
3. Check whether the snow track is still firmly fixed in the dropouts and centered with respect to the frame or fork.
4. Check the handlebars and stems to confirm that neither are bent or broken, and that they are level and upright. Make sure the stem is firmly fixed on the fork by trying to turn the handlebars relative to the front wheel. Briefly lean on the brake levers to make sure the handlebars are firmly fixed in the stem

5. Realign the components if necessary and carefully tighten the bolts to ensure reliable clamping of the components. The maximum torque values are printed directly on the components and/or specified in the enclosed operating instructions. If neither are available, contact ENVO support for assistance
6. Confirm the saddle is not out of alignment, using the top tube or the bottom bracket shell as a reference. If necessary open the clamp, realign the saddle and re-tighten the clamp.
7. Keep an eye on the removed battery and ensure it is kept on a fire safe surface. Check for any signs of damage on the battery case, listen for rattling or the sound of loose particles inside, look for smoke, and ensure the battery or its parts do not get warm on their own. If nothing suspicious is detected after 15-20 minutes, try connecting the battery and turning on the system for an electricity check.
8. Check the display. Are all the values displayed as usual? Do not use your SnowBike if the display shows an error message or a warning. If necessary, switch off the system and wait at least 10 seconds before turning it on and checking it again
9. Take a good look at the whole SnowBike to detect any deformation, colour changes, cracks. Ride back very carefully or walk your SnowBike back to a professional mechanic and have the mechanic check the SnowBike and help resolve any issues
10. If you have had an accident and are unsure whether your SnowBike will function properly, leave your bike rather than risk riding and endangering yourself and others
11. If you do ride your SnowBike, do not accelerate or brake hard until the bike has been checked by a mechanic
12. Deformed components, especially those made of aluminum, can break without previous warning. If this occurs, they may not be repaired, i.e. straightened, as the imminent risk of breakage will remain. This applies in particular to the fork, the handlebars, the stem, the cranks, the seat posts and the pedals. When in doubt, you should replace these components
13. At no time should you make any modifications to your SnowBike Kit electrical systems, unless they are explicitly approved by the manufacturer in writing
14. Contact ENVO support for repairs and replacement parts in case of damage

WARNING

Do not set off on your bike with drive assistance if the control element shows a warning. Doing so could lead to serious injury or death.

7.3. TROUBLESHOOTING TABLE

COMPONENT	ISSUE	CAUSE	SOLUTION
Charger	Charger gets hot	This is normal	Give the charger plenty of space in a well ventilated room
Battery	Power cuts and screen turns off	Low charge	Charge the battery
		LCD display connector is loose	Reconnect and check all other connections inside the controller housing
Battery	Battery cable connector is melted	Dust and dirt may cause loose connections between connection pins which can cause sparking that leads to melting	Make sure to frequently keep connections clean and secured. Order replacement parts
Battery	Battery does not charge up with standard charger	Battery is already fully charged	Check battery voltage by pressing the power button two times after turning on the display. You will see the voltage on the right bottom corner. Above 41V for 36V is considered fully charged, and above 53V for 48V is considered fully charged
		Charger does not function	Green LED may turn on when charger is plugged into battery but not connected to the wall. Check all connections are tight Try different plugs as well as different charger cables
Pedal Assist	System is on, Pedal Assist is not working, but the throttle is working	PAS sensor is disconnected	Check wires and connections or restore parameters to default

Throttle	System is on and the throttle not working but the Pedal Assist is working	<p>Throttle has a connection issues</p> <p>Throttle magnet can see interference from any nearby metal objects</p> <p>Error info 01</p>	<p>Check connections</p> <p>Try moving metal objects further away from throttle</p> <p>Check throttle positioning. Clean throttle area. It may be stuck on something, make sure you leave some space around the throttle</p>
Motor	Motor making noise	<p>This is normal when motor is under heavy load (hills, heavy cargo)</p> <p>Motor vibrations causing resonance on other bicycle components</p>	<p>Try giving motor more assist under heavy loads</p> <p>Reposition parts and add vibration damping between parts, make sure motor is secured</p>
Motor	System is on but motor has no power	<p>Loose connections</p> <p>Brake cut off sensor is malfunctioning</p> <p>Battery not sufficiently charged</p>	<p>Check connections and reconnect, make sure to align arrows</p> <p>Disconnected the brake cut off sensor, check if motor is powering</p> <p>Check battery voltage,. If below 34V the system will turn on but motor will not give power</p>
LCD Display	Every time I restart the ebike the display clock needs reset	LCD has small battery inside that does not come fully charged	Small battery needs to be charged for 72 hours
LCD Display	Error 30H	Occurs when green pin connection comes loose or disconnected or pins become bent	Check connection and pins should be straight, reconnect

Gear shifter	Gears skipping	Derailleur not in optimal position for gear	Adjust derailleur position with barrel adjuster located on the shifter
Brakes	Brakes making noise	<p>Brake pads are rubbing on the rotor</p> <p>Brakes not bedded in properly, material buildup is causing noise</p>	<p>Pads need to be adjusted. Adjust the cable tension to shift the left pad, use an Allen key to adjust the right pad. The pads should be adjusted so the rotor spins freely in the middle of the two pads</p> <p>Lightly sand and clean rotors and pads. Bed in your brakes, see section 5.6.</p>

For any additional troubleshooting help, refer to support.envodrive.com or contact your local ENVO Electric Bike dealer.

8. TRANSPORTATION & STORAGE

8.1. TRANSPORTATION

- Please be careful when loading your SnowBike onto a vehicle rack
- Be aware of battery cables and other wires when loading and unloading

WARNING

Misuse of vehicle racks could result in potentially hazardous situation that could lead to property damage serious injury or death.

8.2. STORAGE

- Always fully charge the battery prior to storage
- Check and charge your battery at least every 2 months
- Always store your SnowBike somewhere where it is protected from rain, snow, or sunlight
- Always store the battery in a cool, well ventilated room away from freezing temperatures
- You may also seal the terminals with tape to protect against any short circuit

9. GENERAL TERMS & WARRANTY

9.1. WARRANTY

- All ENVO Drive Systems products as well as components purchased including motor, controller, display, battery, charger, throttle, PAS sensor, brake sensors are covered by 12 months FREE warranty unless otherwise specified. You can purchase an extended warranty up to 24 months where offered
- Although our warranty is designed to ensure you receive a perfect product at the time of purchase your product will still require maintenance by the user
- Replacement mechanical parts such as chain, brake, tire, gear adjustment or loose screws or connectors are not covered under the warranty. The warranty is for intrinsic parts defects only
- We do not offer bicycle service and tune up as a part of warranty service
- The warranty supports you if you have intrinsically defective parts such as a cracked frame weld seam or controller circuit failure. It does not include labour or delivery
- Delivery of the defective products or parts for repair or replacement to our service shop is the customer's responsibility
- An ebike is a vehicle that functions in real working conditions and is exposed to unwanted impacts, shocks, vibrations, heat and cold, accidents, water penetration, salt splash etc. which may cause damage. These damages are not covered under the warranty
- If you find a defective product or part within the eligibility period, we supply will supply a free replacement part for you. You might be billed for the cost of delivery or installation fee
- If the problem is caused by an accident, wrong or careless installation by the customer, wire stretch, bad storage or not following the instruction manual, the customer will pay the cost of the part and replacement. The cause of the failure and warranty eligibility should be verified by the head of our technical department
- Our warranty terms and conditions apply to all customers purchasing our products through dealers, 3rd party or second hand
- If a warranty extension is offered for any of our products, you can pay the fee and get covered for the extension through the same terms and conditions. You may apply up to 1 day before the regular warranty period expires

IMPORTANT NOTE:

ENVO does not offer tune-up and snow product mechanical services beyond limited installation or repairs of electrical system.

9.2. WARRANTY TERMS

ENVO Drive Systems warranty covers the full warranty period for all parts of the SnowBike Kit for the first owner, within the framework of the following conditions:

- This warranty covers the repair and/or the replacement of SnowBike Kit components.
- Costs for repair work performed in advance by persons who have not been authorized by ENVO Drive Systems will not be reimbursed. In such a case, any warranty claims will cease.
- The warranty period starts with the date of purchase. Warranty claims must be reported immediately.
- If the battery pack does not provide full capacity in the course of normal use, or for batteries going through a normal aging process that have a reduction of performance, the ENVO Drive Systems warranty covers batteries that fit these conditions within the warranty period. The battery capacity must prove to be less than 70% of initial condition.
- No warranty claims are accepted in the case of damages due to the following:
 1. External influences, particularly falling rocks, collision, normal wear and tear, improper handling, acts of god, accident and other external events with an immediate external effect due to mechanical powers.
 2. Purposeful and/or malevolent acts, theft and robbery as well as natural hazard events and/or acts of mischief.
 3. Inappropriate use, e.g. the product was exposed to liquids, chemicals of any type and/or extreme temperatures, wetness and humidity and/or if the battery suffers damages due to non-compliance with instructions.
 4. Overcharging the battery or not adhering to the instructions of battery handling.
 5. In the case of test, maintenance, repair and replacement work due to normal use.
 6. In the case of use of the battery in systems that are not approved for such use with this particular product.
 7. In the case of the operation of the ENVO Drive Systems system with batteries other than the batteries designed for the SnowBike Kit system (refer to user manual).

8. If one or more than one ENVO Drive Systems part has been opened, altered or repainted.
9. The warranty does not cover any SnowBike that has been structurally altered, neglected, improperly maintained, or used for purposes other than for which it was manufactured.

This warranty only covers the mentioned repair work and/or the replacement of defective or compromised components. It excludes any claims for the reimbursement of property damages, downtimes, and expenses for renting or leasing equipment, travel expenses, lost profit or any other claims. ENVO Drive Systems liability in connection with this warranty is limited to the respective acquisition value of the product.

This warranty only covers original ENVO Drive Systems components. The use of spare parts from unknown sources, for example, replacement parts from third parties, is strictly prohibited.

Warranty will be voided on any system on which it will be concluded that there has been any case of modification or tampering with firmware.

9.3. REGISTERING YOUR PRODUCT WARRANTY

Please register your ENVO Drive Systems product by submitting filling out our product warranty registration form at envodrive.com/warranty-registration.

IMPORTANT NOTE:

You must register your electric bike with ENVO Drive Systems within 30 days of receiving your product for warranty to be valid.

9.4. LIABILITY DISCLAIMER

ENVO Drive Systems will not take any responsibility and/or liability for any accident, misuse, abuse, loss, injury for or by the rider or a third party, even if caused by a SnowBike Kit power, speed, bad or illegal parameter setting, components, defect or malfunction. If you buy a SnowBike Kit or parts with no installation and service or if the kit is installed by us, the customer takes all responsibilities and liabilities for the SnowBike, SnowBike components, brakes, SnowBike mechanical parts and adjustments, electrical wiring, unforeseen occurrences, safety issues, maintenance and services, etc.

SnowBike riders must obey all traffic regulations and follow the rules and laws surrounding the type of vehicle they are using.

9.5. EXCLUSIONS

ENVO is released and discharged of any liability for any damages, injuries or claims occurring as a result of neglect, the owner is responsible for the maintenance and safety of all structural and mechanical components of their SnowBike.

9.6. SATISFACTION GUARANTEED

We offer guaranteed satisfaction on all our products and services. We provide in-depth free technical sales support to ensure you choose the product that best suits your needs.

9.7. CUSTOMER SERVICE

Our highest priority is to provide the best customer service possible and cultivate a long lasting relationship with each client built on trust and respect. Our customer service is not passive; we are available to actively support you through all ordering or service procedures. We are happy to have in depth conversations with our customers about their requirements or problems. Our personal connection with each client is what differentiates us from common “No-Question” customer service models offered by Amazon or department stores. At ENVO we are real hardworking people trying to bring great products and services to you in a way no one else does.

9.8. TROUBLESHOOTING, REPAIRS & TECHNICAL SERVICE

- We have a dedicated Help Center including a troubleshooting guide and user manuals to help customers maintain and fix their system in case of errors or failure. You are required to go through the guides and if the solution is not achieved contact our customer service through our ticketing system, providing all observations for our technicians to help figure out the issue
- 90% of cases can get to a solution at this stage by knowing the problem even without need for sending any replacement parts
- In case the issue is not diagnosed by standard ways; for our hub motor kits, ENVO ebikes, and other house brand products, since the electrical system is modular and has easy access. We would be able to easily send you replacement parts such as a controller to swap and test and return the defective one. You may be required to purchase the parts initially and pay for the shipping costs. You can return the unused parts for full refund later on
- Customers are required to have a level of technical knowledge with tools to recover their system remotely and safely without our assistance
- If at any stage of the diagnostics or even after parts replacement, it turns out to be a part intrinsic defect within the warranty criteria; we will refund the cost of the purchased component as accepted by warranty validated by the head of technical debt

CONTACT



LOCATION

ENVO Drive Systems Inc.

1685 Ingleton Avenue

Burnaby, BC V5C 3V6

Canada



BUSINESS HOURS

Monday – Friday: 10am – 5pm PST

Saturday: 11am – 3pm PST

Sunday: Closed

Please check online to see our most up to date hours



PHONE

+1 (604) 423-3381

Toll free: (888) 229-2980



WEBSITE

envodrive.com

support.envodrive.com