

**BATLSKIN**  
**caiman**<sup>®</sup>

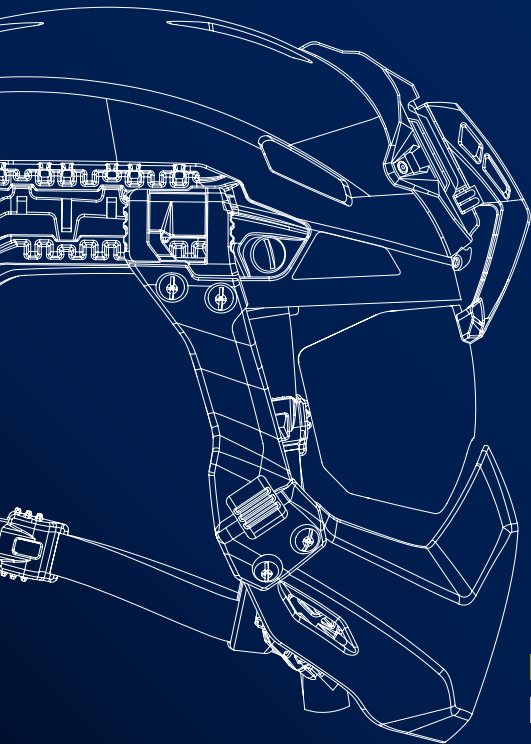

**HEAD PROTECTION SYSTEM**  
**INSTRUCTION GUIDE**



# CAIMAN HEAD PROTECTION SYSTEM

**TO THE OPERATOR** – No matter the pace, the obstacles, or the environment, your command wants you to have full-spectrum protection for your mission. Caiman Helmet Systems were designed based on intensive direct collaboration with SOF users. The end-result: a skeletonized, scalable, lightweight, comfortable system that is purpose-built to integrate with mission-specific headborne equipment. This is cutting-edge head protection for the modern battlefield.

## **GALVION. EMPOWER YOUR MISSION.**

---

**PLEASE BE SURE TO READ ALL INSTRUCTIONS AND FOLLOW ALL WARNINGS. POOR SET-UP AND ADJUSTMENT MAY COMPROMISE THE SYSTEMS ABILITY TO PROVIDE THE PROTECTION THAT IT IS DESIGNED TO DELIVER DURING A BLUNT FORCE OR BALLISTIC IMPACT. SIZING, WARRANTY AND WARNING INFORMATION CAN BE FOUND BY SCANNING THE QR CODE.**



**HAVE QUESTIONS OR COMMENTS? CONTACT GALVION CUSTOMER SUPPORT**  
**1-866-713-0406 | [CUSTOMERCARE@GALVION.COM](mailto:CUSTOMERCARE@GALVION.COM) | [GALVION.COM](http://GALVION.COM)**

# CONTENTS

This manual provides information regarding the components of your Batlskin Caiman Head Protection System. This helmet was developed to provide the best blunt force and ballistic protection in a scalable, lightweight package that is fully modular and fully integrated.

HELMET ANATOMY		FIT & CUSTOMIZATION		ACCESSORY COMPATIBILITY	
Caiman Helmet	5	Sizing	8	Fixed Arm Visor	19
APEX Liner	6	How to measure head size	8	NVG Arm Visor	20
Rails	7	Helmet	9	Mandible Guard	21
		Mandible	10	Ballistic Applique	22
		Adjusting Retention System	11		
		Adjusting Fitband System	13	Care & Support	23
		Adjusting Suspension System	14		
		Headset Integration	15		
		Simplified Liner	16		
		Rail management	17		
		Bolt Installation & Removal	18		

## CAIMAN HELMETS

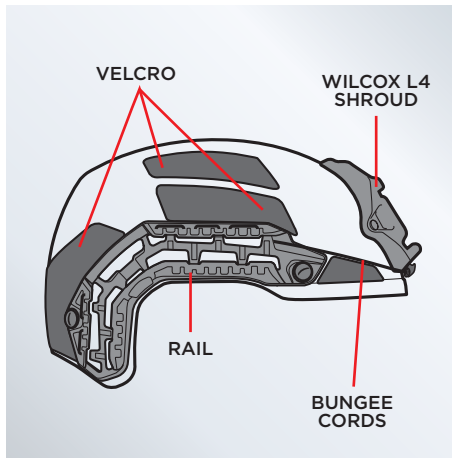

**BALLISTIC**

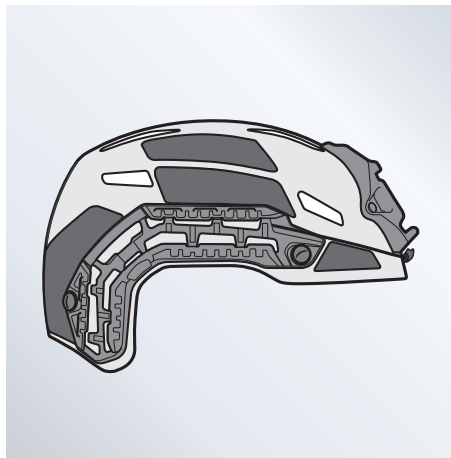

**BUMP/HYBRID**

## APEX LINER

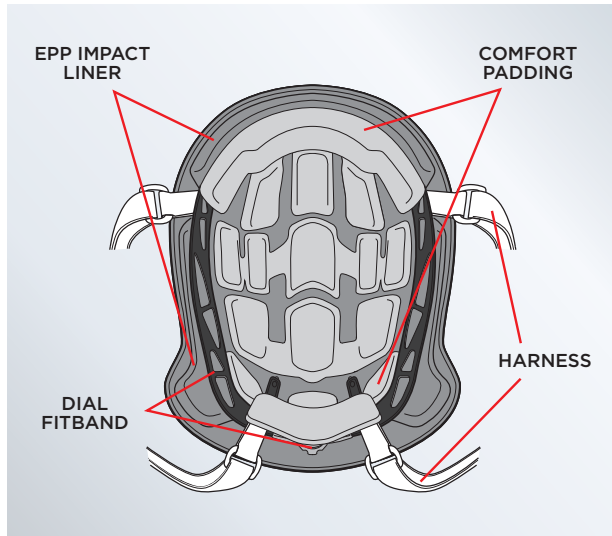

# RAILS

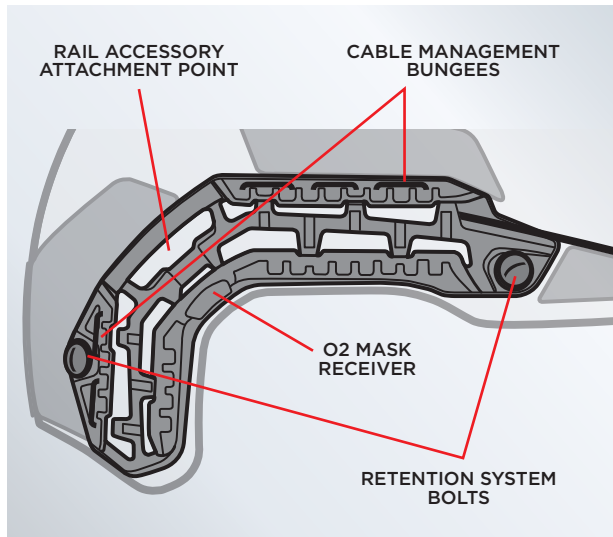

Use cable management bungees to secure power or data cables.

## SIZING - HOW TO MEASURE HEAD SIZE

User will obtain the most accurate head measurements using a tape measure for circumference and a caliper for length and width.

Evaluate size while wearing the typical, everyday headwear, hairstyle, head coverings, etc., worn with helmet.

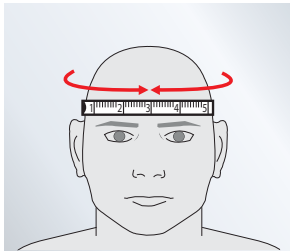

Using a measuring tape at approximately  $\frac{1}{2}$ " above eyebrows and ears, measure head **CIRCUMFERENCE**.

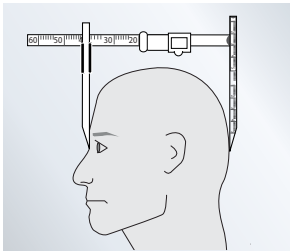

In the absence of a caliper, use 2 pencils. Hold one pencil between eyebrows and one at the back of head. An extra set of hands is important to ensure pencils are straight. Measure distance between pencils - this is the **LENGTH** measurement.

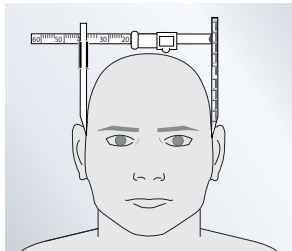

In the absence of a caliper, use 2 pencils. Hold one pencil at either side of head above ears. An extra set of hands is important to ensure pencils are straight. Measure distance between pencils - this is the **WIDTH** measurement.



## SIZING - HELMET

- Head circumference is the best predictor of helmet size – start there and refine using length and width measurements as needed.
- Be sure to also evaluate fit with additional equipment (headset, cold weather gear, eye protection, etc.) as these will all affect the amount of space needed in helmet.
- With use, liners get worn in and compressed or stretched, and helmet may feel larger so make sure to have snug fit when trying on with new liner system.

SIZING CHART		CIRCUMFERENCE	LENGTH	WIDTH
SMALL	inch	20 <sup>5</sup> / <sub>8</sub> - 22 <sup>1</sup> / <sub>2</sub>	up to 8 <sup>1</sup> / <sub>8</sub>	up to 6 <sup>1</sup> / <sub>2</sub>
	mm	525 - 570	up to 205	up to 165
MEDIUM	inch	21 <sup>1</sup> / <sub>2</sub> - 23 <sup>1</sup> / <sub>4</sub>	up to 8 <sup>1</sup> / <sub>4</sub>	up to 6 <sup>7</sup> / <sub>8</sub>
	mm	545 - 590	up to 210	up to 175
LARGE	inch	22 <sup>1</sup> / <sub>2</sub> - 24	up to 8 <sup>1</sup> / <sub>2</sub>	up to 7 <sup>1</sup> / <sub>4</sub>
	mm	570 - 610	up to 215	up to 185
X-LARGE	inch	23 <sup>1</sup> / <sub>4</sub> - 24 <sup>3</sup> / <sub>4</sub>	up to 8 <sup>5</sup> / <sub>8</sub>	up to 7 <sup>1</sup> / <sub>2</sub>
	mm	590 - 630	up to 220	up to 190
XX-LARGE	inch	24 - 25 <sup>3</sup> / <sub>4</sub>	up to 9	up to 7 <sup>5</sup> / <sub>8</sub>
	mm	610 - 655	up to 230	up to 195

## SIZING - MANDIBLE

Mandible size is based on face length and does not necessarily correspond with user helmet size; for example user may wear a Large helmet but require a size XL-XXL size mandible.

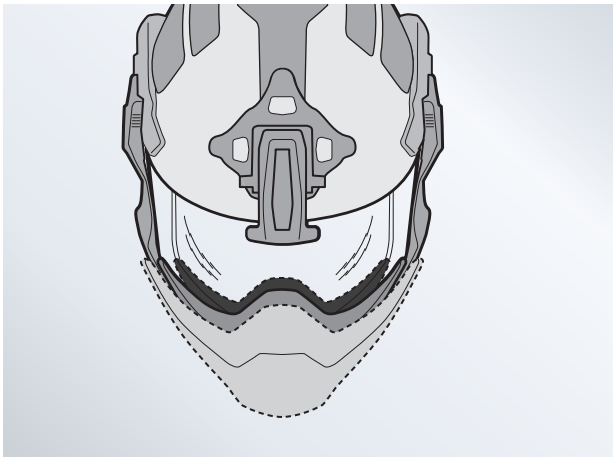

**2 SIZES:** SM-MD-LG and XL-XXL.

Both sizes are compatible on **ALL** helmets.

## ADJUSTING RETENTION SYSTEM

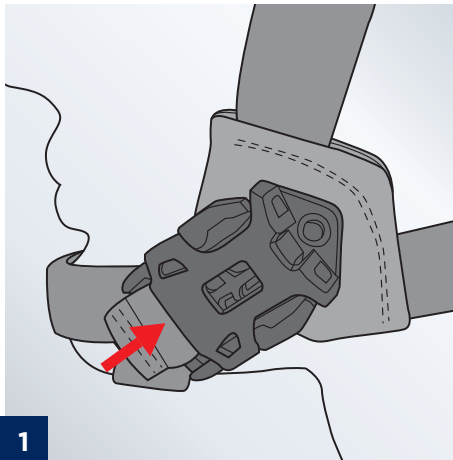

Buckle chinstrap.

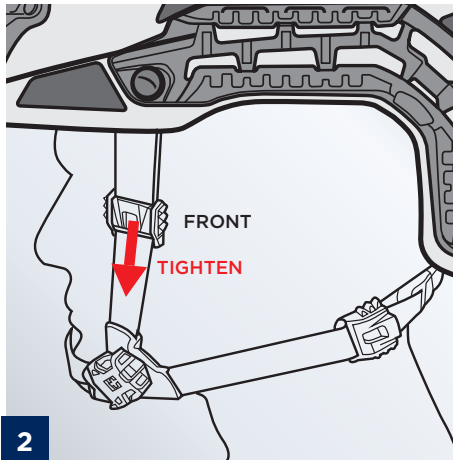

Unlock front tensioner and tighten as needed. Lock in place.

Users may find it easier to adjust tensioners on both left and right side of harness at the same time.

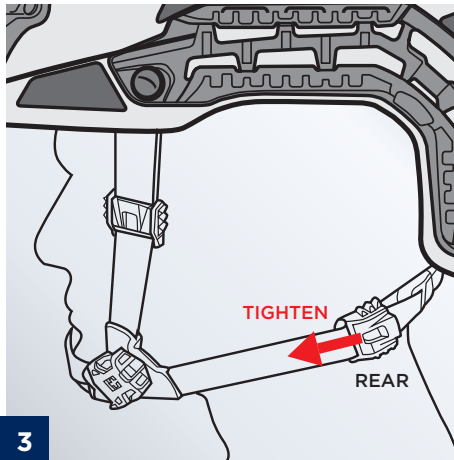

Unlock rear tensioner and tighten as needed. Lock in place.

Users may find it easier to adjust tensioners on both left and right side of harness at the same time.

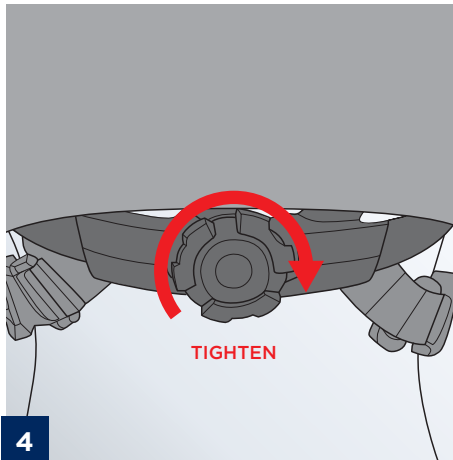

Tighten fitband by turning the dial clockwise.

## ADJUSTING FITBAND SYSTEM

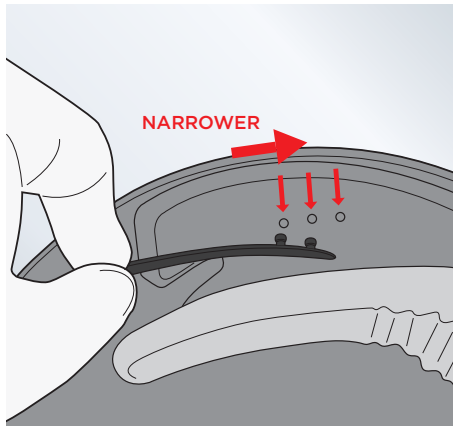

### FITBAND TOO LOOSE?

Snap fitband arm posts towards front of helmet for narrower fit.

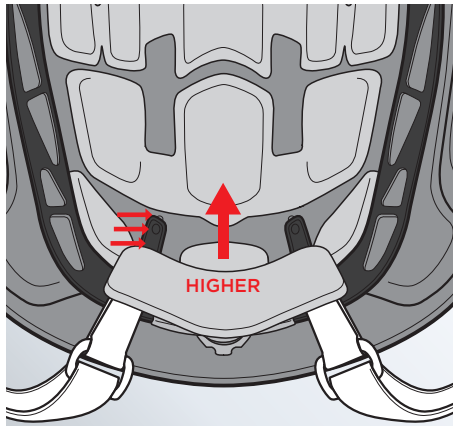

### NAPE PAD TOO LOW?

Nape pad should rest at the base of skull. Adjust higher if needed.

Users may prefer a higher nape pad position for increased neck range of motion while in the prone position.

## ADJUSTING SUSPENSION SYSTEM

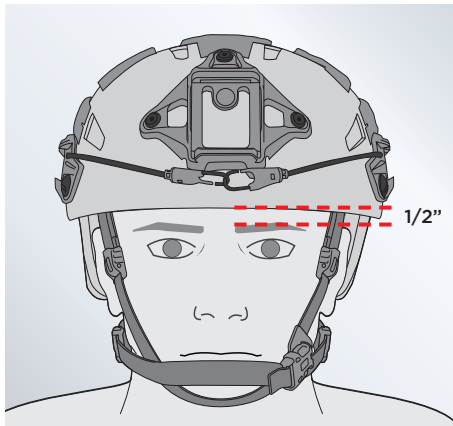

Helmet should sit 1/2" above brow.

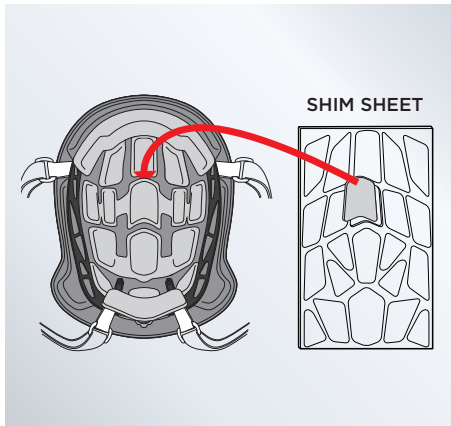

Shims can be added underneath comfort pads to provide additional localized thickness where needed.

## HEADSET INTEGRATION

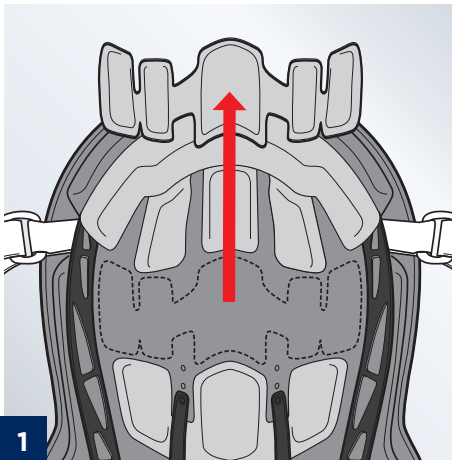

1

Remove the center comfort pad.

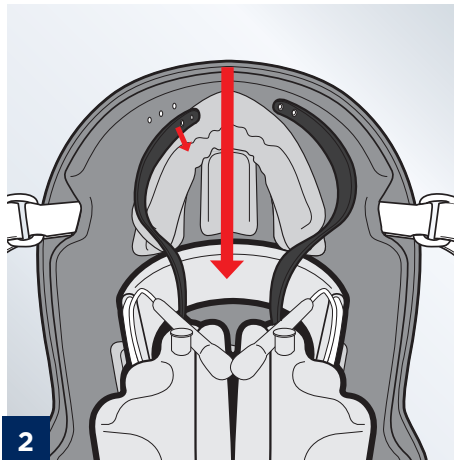

2

(OPTIONAL) Make helmet and headset a single unit by weaving headset through fitband arms and re-attaching.

## SIMPLIFIED LINER CONFIGURATION (OPTIONAL)

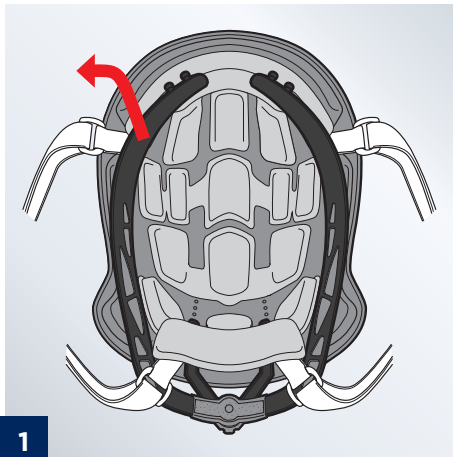

Un-snap front and nape pad fitband arms from helmet and remove the fitband entirely.

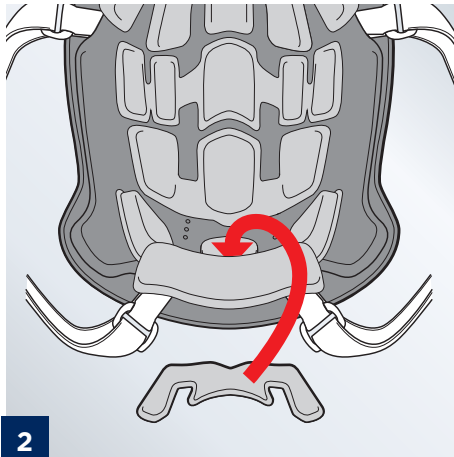

For added stability and comfort, install nape comfort pad.



## RAIL MANAGEMENT

Should you need to remove rails for any reason, please follow these preparatory steps.



**1** Remove front comfort pad.



**2** Remove fitband.

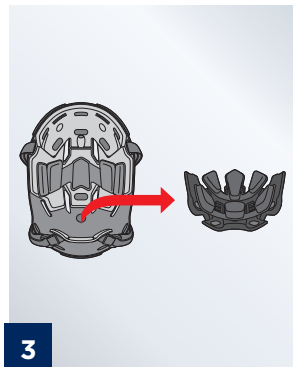

**3** Remove rear impact pad liner section.

## BOLT INSTALLATION & REMOVAL

If removing rails, please use the shorter bolts included with Caiman accessory kit.

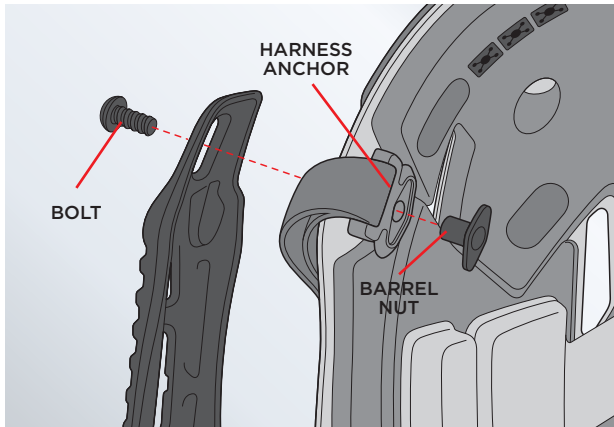

The barrel nut should fit flush in the harness anchor and the bolt should be tight, whether helmet has rails installed or not. When installing rails, user should fully tighten only once rail bolts are installed at both ends.

Rear impact liner, fitband and front comfort pad should be re-installed in helmet once all bolts have been secured.

## FIXED ARM VISOR

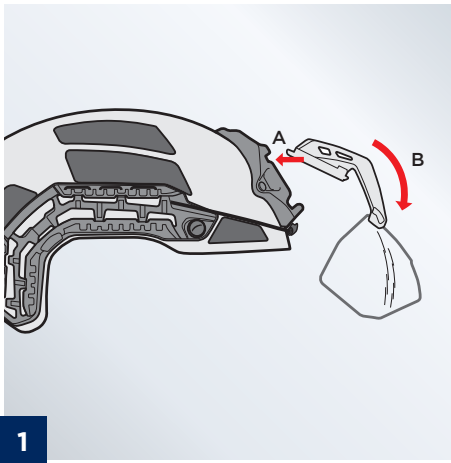

- A.** Insert top edge of visor arm into shroud.  
**B.** Tilt visor arm down and lock visor into shroud.

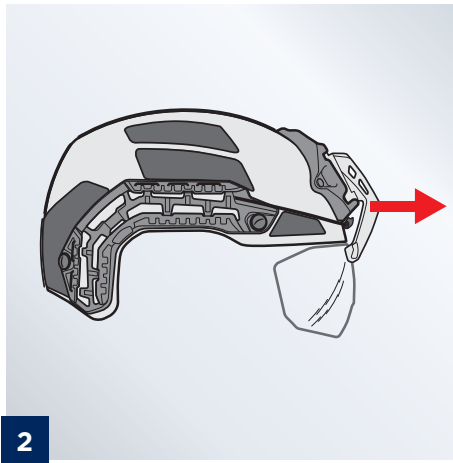

- Pull on visor arm to ensure it is secured in place – it should not release.

## NVG ARM VISOR

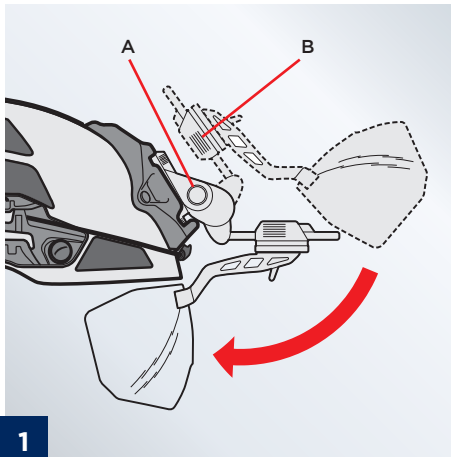

**1**  
**A.** Attach Wilcox L4 G24 or G22 NVG mounting arm to the shroud.

**B.** Insert the NVG arm visor into the shoe of the Wilcox mounting arm.

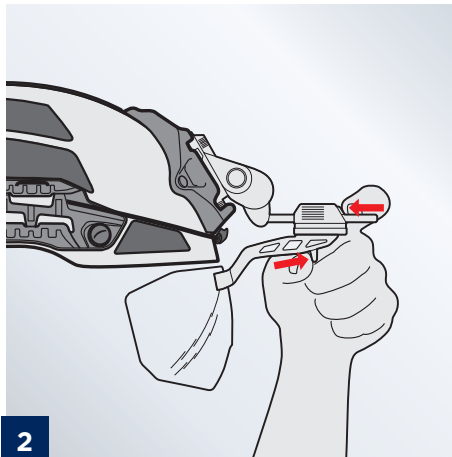

**2**  
Remove the visor by pressing on latch and arm release.

## MANDIBLE GUARD

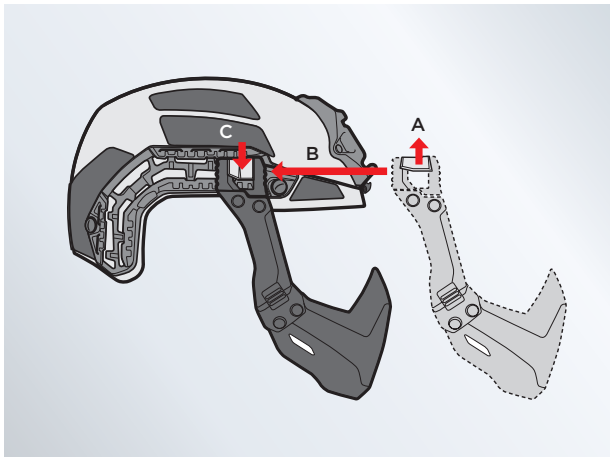

- A.** Open mandible arm latches.
- B.** Insert mandible arms into rail until they stop.
- C.** Lock mandible arm latches.

## BALLISTIC APPLIQUE

FOR USE WITH CAIMAN HYBRID HELMET ONLY

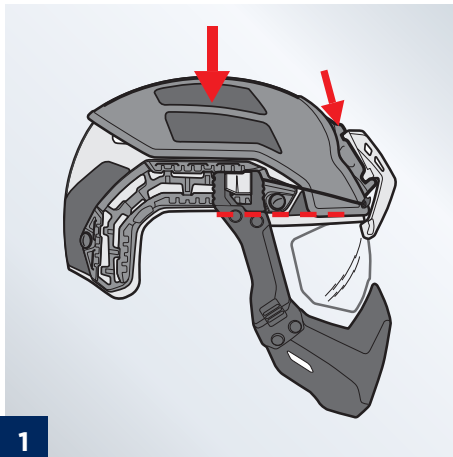

Line up top applique with NVG shroud and push down to adhere.

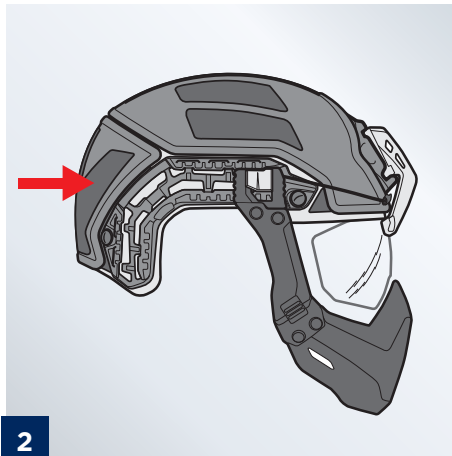

Apply back applique flush with rear of helmet. Press to adhere.

# CARE & SUPPORT

## GENERAL CARE

Wash the helmet and components in warm, soapy water and rinse thoroughly with fresh water. Let air dry.

## AFTER EXPOSURE TO SALT WATER

Rinse all components, including metal, with fresh water.

**IF ANY COMPONENT OF THE HELMET SYSTEM IS CRACKED, DENTED, WORN, FRAYED OR OTHERWISE DAMAGED, REPLACE COMPONENT IMMEDIATELY.**

## SUPPORT

For any support related to your helmet, including replacement parts, accessories, warranties and general product information, please reach out to our team.

**HAVE QUESTIONS OR COMMENTS? CONTACT GALVION CUSTOMER SUPPORT**

**1-866-713-0406 | [CUSTOMERCARE@GALVION.COM](mailto:CUSTOMERCARE@GALVION.COM) | [GALVION.COM](https://www.galvion.com)**



©2022 GALVION INC. ALL RIGHTS RESERVED. GALVION™, BATLSKIN® AND BATLSKIN CAIMAN® ARE TRADEMARKS OF GALVION INC. OR ONE OF ITS AFFILIATES.  
5-0008-0029 GAL2325\_0422 REV G