

NHL-FP



USA Company

CCT/WATT ADJUSTABLE BACKLIT LED FLAT PANEL

Dual Selectable Panels are commercial luminaires utilizing advanced driver technology to provide an all in one luminaire. providing 3 wattages and 3 CCT options in each size panel. This provides superior lighting performance while minimizing inventory by reducing the amount of stocking SKUs. They achieve high uniformity energy efficiency and reduced glare in typical T-bar grid ceiling applications.

Our state-of-the-art backlit LED technology utilizes PMMA lensing over the LEDs which will not discolor over time. The need for a light guide is eliminated, thus increasing photometric performance while keeping costs competitive. Combined with the rigid back enclosure that prevents warping in application, this luminaire is designed for worry-free longevity and reliability. Available with factory installed battery backup for 90 minutes emergency egress illumination.

SPECIFICATIONS

CONSTRUCTION

- Aluminum frame in white finish, steel die-formed back enclosure

OPTICS

- PMMA lenses over LEDs, PS diffuser
- SDCM < 5
- UGR < 22
- 120° Beam angle

ELECTRICAL

- 0-10VDC Dimming (10%-100%)

CERTIFICATIONS

- cULus Listed for Damp Locations
- IC Rated for insulated ceilings • -20°C to 35°C (4°F to 95°F)
- RoHS, FCC

WARRANTY

- 5 Year

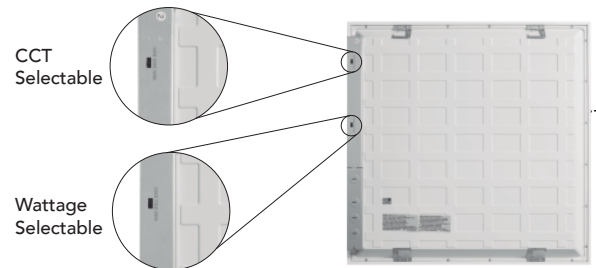

INSTALLATION

- Recessed in T-bar grid ceiling with integral earthquake clips for secure attachment
- Surface mount and suspension mount cable kit accessories available

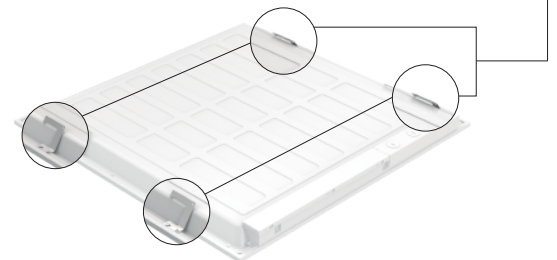

QUICKSHIP ORDERING INFORMATION

Catalog No.	Description	Weight	Qty/Carton	Qty/Pallet
NHL-FP24-45W-CT-UNV-G2	2x4 LED Flat panel, 30/40/45 adj wattage, 3500/4000/5000K, CCT adj, 120-277V, 0-10VDC dimming	9.2 lbs	2	44
NHL-FP24-45W-CT-UNV-G2-EM	2x4 LED Flat panel, 30/40/45 adj wattage, 3500/4000/5000K, CCT adj, 120-277V, 0-10VDC dimming, EMERGENCY BATTERY	16 lbs	1	22
NHL-FP22-36W-CT-UNV-G2	2x2 LED Flat panel, 20/30/36 adj wattage, 3500/4000/5000K, CCT adj, 120-277V, 0-10VDC dimming	5.2 lbs	2	72
NHL-FP22-36W-CT-UNV-G2-EM	2x2 LED Flat panel, 20/30/36 adj wattage, 3500/4000/5000K, CCT adj, 120-277V, 0-10VDC dimming, EMERGENCY BATTERY	11 lbs	1	36
NHL-FP14-40W-CT-UNV-G2	1x4 LED Flat panel, 20/30/40 adj wattage, 3500/4000/5000K, CCT adj, 120-277V, 0-10VDC dimming	5.2 lbs	2	66
NHL-FP14-40W-CT-UNV-G2-EM	1x4 LED Flat panel, 20/30/40 adj wattage, 3500/4000/5000K, CCT adj, 120-277V, 0-10VDC dimming, EMERGENCY BATTERY	11 lbs	1	32

*Note: Factory installed battery backup provides 90 minutes of illumination when AC power is removed

BACKLIT LED FLAT PANEL

SPECS AT A GLANCE

Size	NHL-FP24 (2X4)			NHL-FP22 (2X2)			NHL-FP14 (1X4)		
Wattage	30	40	45	20	30	36	20	30	40
CCT	3500K/4000K/5000K			3500K/4000K/5000K			3500K/4000K/5000K		
Lumens	3750/3825/3825	5000/5100/5100	5625/5738/5738	3750/3825/3825	5000/5100/5100	5625/5738/5738	3750/3825/3825	5000/5100/5100	5625/5738/5738
Efficacy (LPW)	125-127.5			125-127.5			125-127.5		
CRI	80								
Input Voltage	120-277VAC, 0-10VDC Dimming								
Certifications	cULus, Damp Location, FCC, RoHS								
Operating Temp	-20°C to 40°C (4°F to 104°F)								
Warranty	5 Years								

MAKE-TO-ORDER ORDERING INFORMATION

NHL-FP

EXAMPLE NHL-FP22-30W-50K-UNV

	SERIES	SIZE	WATTAGE	CCT	INPUT VOLTAGE	OPTIONS
DREAM PANELS	NHL-FP	24 = 2x4	30/40/45	35K=3500K 40K=4000K 50K=5000K	UNV = 120-277V	EM = WITH EMERGENCY BACKUP
		22 = 2x2	20/30/36			
		14 = 1x4	20/30/40			

DIMENSIONS

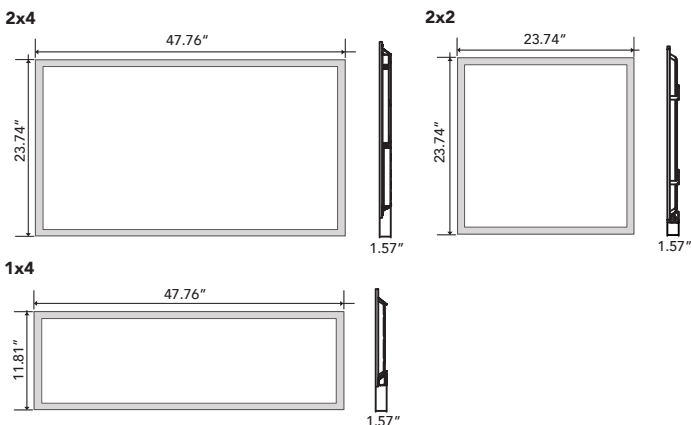

PHOTOMETRY

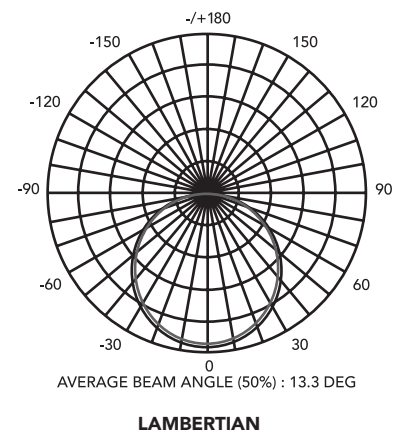

BACKLIT LED FLAT PANEL

MOUNTING ACCESSORIES

SURFACE MOUNT KITS

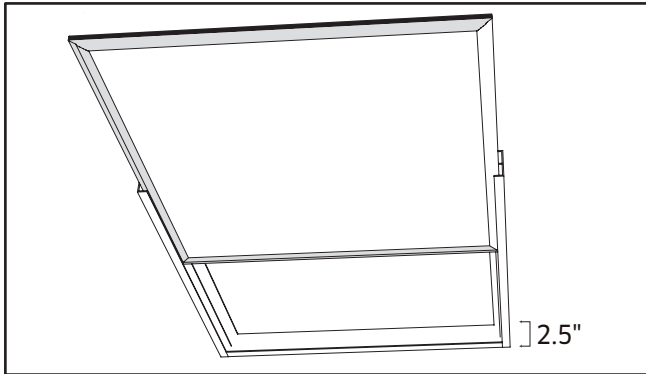

NHL-FP-SMK-14

1x4 Surface Mount Kit, White

NHL-FP-SMK-22

2x2 Surface Mount Kit, White

NHL-FP-SMK-24

2x4 Surface Mount Kit, White

SUSPENSION CABLE MOUNT KITS

(Max. Adjustment Range: 3.86 Feet; Min. Adjustment Range: 0.58 Feet)

1X4 Kits

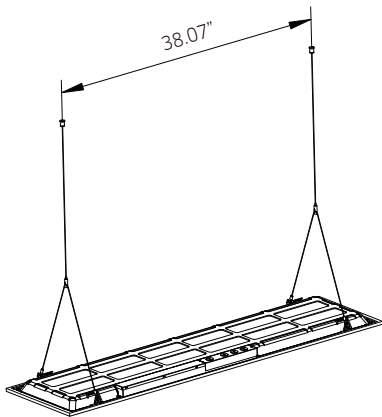

NHL-ACH-60 2-Cable Kit

2X2 Kits

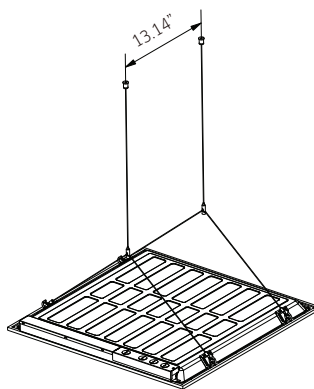

NHL-ACH-60 2-Cable Kit

2X4 Kits

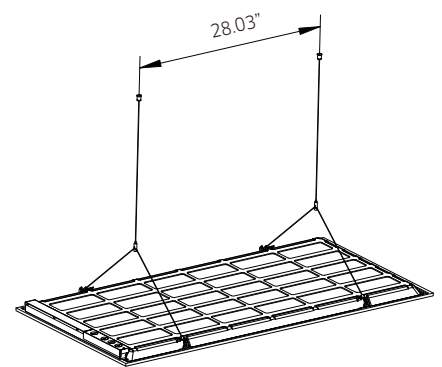

NHL-ACH-60 2-Cable Kit

38.07" 10.51"

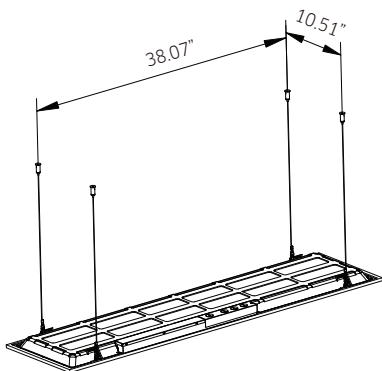

NHL-ACH-FP4 4-Cable Kit

22.32" 13.14"

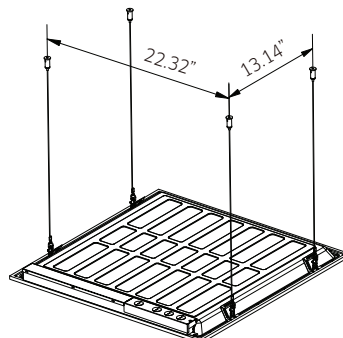

NHL-ACH-FP4 4-Cable Kit

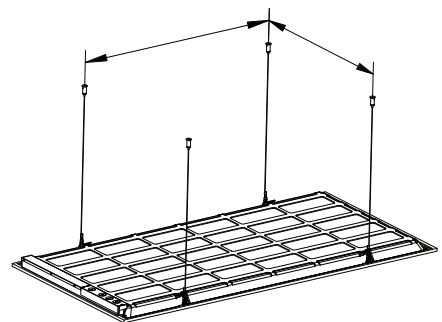

NHL-ACH-FP4 4-Cable Kit