



# NHL-ESED

## EDGE LIT THERMOPLASTIC EXIT SIGN



EXIT

### STANDARD



### OPTIONAL



### ILLUMINATION

- Ultra bright, energy efficient, long life Red or Green LEDs.
- UV-stabilized ultra-clear acrylic edgelit panel provides consistent, uniform illumination.
- Double face utilizes factory installed silver or white mylar background panel.

### ELECTRICAL

- Dual 120/277 voltage standard.
- Unique bi-color LED indicator light alerts occupant on battery condition (Green-normal, Red-check battery).
- Push-to-test switch for mandated code compliance testing.
- 4.8V long life maintenance-free, rechargeable NiCd battery (EM models only).
- Internal solid-state transfer switch automatically connects the internal battery to LED board for minimum 90-minute emergency illumination.
- Fully automatic solid-state, two rate charger initiates battery charging to recharge a discharged battery in 24 hours.

### MOUNTING

- EZ-snap mounting canopy included for top, end or back mount.

### HOUSING

- Injection-molded, engineering grade 5VA, flame retardant, high-impact resistant thermoplastic housing in silver, white, or black finish.
- Self-adhesive Chevron appliques and guide template provided for directional indication.

### OPTIONS

- Custom: Signs available with requested 'special' wording.
- SDT: Self-diagnostic feature performs monthly, biannual, and annual tests to ensure reliable operation and meets electrical and life safety codes.
- 2C: Dual circuit option on the AC-only unit enables it to be connected to two different (one acting as a back-up to the other) supplies at the same time.
- SPV: UL Listed for 208/220/240 Volt, 50/60Hz.

### WARRANTY / LISTING

- Five year warranty on all electronics and housing. Battery is prorated for five years.
- Meets UL924, NFPA 101 Life Safety Code, NEC, OSHA, Local and State Codes.
- UL Listed for damp locations (0°C – 50°C).
- Certified to CEC under Title 20 Regulations.

### DIMENSIONS

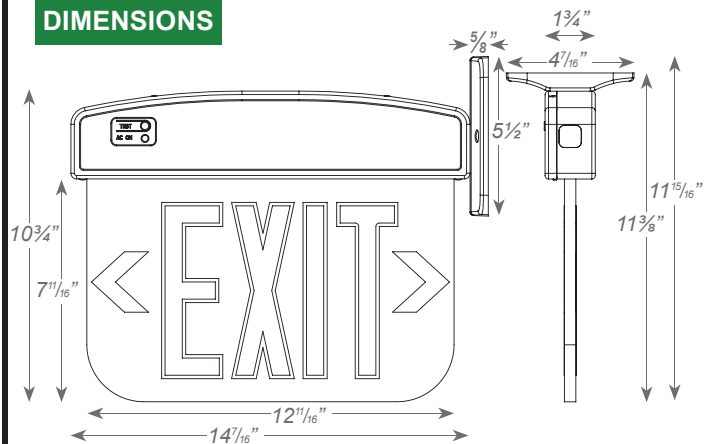

NHL-ESED

### ORDERING INFORMATION

Sample Part Number: NHL-ESED-1-R-W-A

MODEL	No. of FACES	LETTER COLOR	PANEL	HOUSING COLOR	BATTERY	OPTIONS	
NHL-ESED	1	Single Face	R Red	C Clear <sup>1</sup>	W White	(blank) AC-Only	CUSTOM Custom Wording
	2	Double Face	G Green	M Mirror	B Black	EM Battery Backup	SDT Self-Diagnostics <sup>2</sup>
				W White	A Silver		2C Dual Circuit Operation <sup>3</sup>
						SPV 208/220/240 Volt, 50/60Hz <sup>4</sup>	

<sup>1</sup> With single face only.

<sup>2</sup> Available only with EM units.

<sup>3</sup> Available only with AC units.

<sup>4</sup> Not available with SDT.